

Prepared by and Return to:  
Hernando County Attorney's Office  
20 North Main Street, Suite 462  
Brooksville, Florida 34601-2850

## PERPETUAL UTILITY EASEMENT

THIS EASEMENT, made this 15<sup>th</sup> day of November, 2022, between **MD Automotive Group, LLC**, a Florida limited liability company, property owner, whose address is 3939 US Highway 19, New Port Richey, Florida 34652, hereinafter referred to as the "Grantor", and **Hernando County Water and Sewer District**, a body corporate and politic of the State of Florida, by and through its Board of County Commissioners, whose address is 15470 Flight Path Drive, Brooksville, Florida 34604, hereinafter referred to as the "Grantee".

### WITNESSETH:

The Grantor, in consideration of the sum of Ten Dollars and No Cents (\$10.00) and other good and valuable consideration in hand paid by the said Grantee to the Grantor, receipt whereof is hereby acknowledged, has granted, quitclaimed and conveyed unto the said Grantee, its successors and assigns forever, a Perpetual Utility Easement and right-of-way, hereinafter referred to as the "Easement", for the purpose of clearing, excavating, constructing, installing, inspecting, improving, operating, repairing and/or maintaining public utility facilities in, upon, under, over, across and through the following described land in the County of Hernando, State of Florida, to wit:

See Exhibits A and B (legal description and sketch consisting of 2 sheets), attached hereto and made a part hereof by reference.

Parcel ID Number: R35 422 18 0000 0050 0000

TO HAVE AND TO HOLD the same unto the said Grantee, its successors and assigns forever, together with the reasonable right to enter and depart over and upon adjoining lands of the Grantor for the purpose of exercising the rights herein granted, so long as the land is restored to as good or better condition than originally found upon completion of construction or maintenance.

Grantor covenants to the Grantee that it is lawfully seized of said land and that it has good, right and lawful authority to grant this Easement.

Grantor hereby covenants and agrees that the Grantor shall not locate, place, construct, install, create, permit or allow any buildings or permanent structures or obstacles (including but not limited to landscaping, trees, fences and walls) within the Easement and the Grantor shall not interfere with the Grantee's utility facilities within the Easement.

NOV 08 2022

RECEIVED

Grantor further covenants to indemnify and hold harmless the Grantee from any and all damages and injuries, whether to persons or property, resulting from interference with the Grantee's utility facilities by the Grantor or its officers, directors, employees, agents, guests, successors or assigns.

**This Easement shall be recorded in the Public Records of Hernando County, Florida.**

IN WITNESS WHEREOF, Grantor has caused these presents to be duly signed the day and year first above written.

Signed, sealed and delivered  
in the presence of:  
(Signatures of two Witnesses required by Florida Law)

Witness: [Signature]

Print Name: BRAD MEREDITH

Witness: [Signature]

Print Name: Jordan Pletscher

Grantor:  
MD Automotive Group, LLC,  
a Florida limited liability company

By: [Signature]  
David L. Maus, Manager

STATE OF FLORIDA  
COUNTY OF PASCO

The foregoing instrument was acknowledged before me by means of  physical presence or  online notarization this 1<sup>st</sup> day of November, 2022, by David L. Maus, as Manager of MD Automotive Group, LLC, a Florida limited liability company, on behalf of the company. He is personally known to me or has produced as identification.

[Signature]  
Signature of Notary  
Print Name: Martha Lucia Erdberg  
Notary Public, State of Florida  
Commission No. HH 218711  
My Commission Expires: 3/23/2026

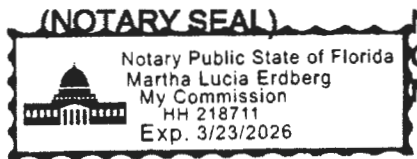

H.C.U.D. ADMIN  
NOV 08 2022  
RECEIVED

# EXHIBIT A

## SECTION 35, TOWNSHIP 22 SOUTH, RANGE 18 EAST HERNANDO COUNTY, FLORIDA

### DESCRIPTION

COMMENCING AT THE NORTHEAST CORNER OF THE NORTHWEST 1/4 OF SECTION 35, TOWNSHIP 22 SOUTH, RANGE 18 EAST, HERNANDO COUNTY, FLORIDA; THENCE ALONG THE EAST LINE OF SAID NORTHWEST 1/4, RUN S00°02'34"E, 56.36 FEET TO THE SOUTH RIGHT-OF-WAY LINE OF WISCON ROAD AND THE POINT OF BEGINNING; THENCE CONTINUE ALONG THE EAST LINE OF SAID NORTHWEST 1/4, S00°06'26"E, 905.14 FEET TO THE SOUTH LINE OF THE NORTHEAST 1/4 OF THE NORTHWEST 1/4 OF SAID SECTION 35; THENCE ALONG SAID SOUTH LINE, RUN N89°59'26"W, 15.00 FEET; THENCE RUN 15.00 FEET WEST OF AND PARALLEL TO THE EAST LINE OF THE NORTHWEST 1/4 OF SAID SECTION 35, N00°06'26"W, 905.11 FEET TO THE SOUTH RIGHT-OF-WAY LINE OF WISCON ROAD; THENCE ALONG SAID SOUTH RIGHT-OF-WAY LINE, RUN N89°52'18"E, 15.00 FEET TO THE POINT OF BEGINNING.

#### LEGEND AND ABBREVIATIONS

C1 = SEE CURVE TABLE	P.G. = PAGE
L1 = SEE LINE TABLE	FN&D = FOUND NAIL AND DISK
(C) = CALCULATED	SIPC = SET IRON PIN AND CAP
(R) = RECORD OR PLAT	FIPC = FOUND IRON PIN AND CAP
R/W = RIGHT OF WAY	FCM = FOUND CONCRETE MONUMENT
P.O.C. = POINT OF COMMENCEMENT	▲ = DESCRIPTIVE POINT
P.O.B. = POINT OF BEGINNING	⊙ = FOUND CONCRETE MONUMENT (AS SHOWN)
SEC = SECTION	○ = FOUND IRON PIN AND CAP (AS SHOWN)
C.L.F. = CHAIN LINK FENCE	△ = FOUND NAIL AND DISK (AS SHOWN)
D.R. = OFFICIAL RECORD	⊠ = FORCEMAIN GATE VALVE

1. BEARINGS ARE BASED ON THE WEST LINE OF PARCEL B.D. ESTABLISHING AN ASSUMED BEARING OF N03°50'31"E AS LISTED IN THE DEED OF RECORD AS RECORDED IN CUR. BOOK 3820, PAGE 549 OF THE PUBLIC RECORDS OF HERNANDO COUNTY, FLORIDA. BEARINGS SHOWN HEREON ARE BASED ON ASSUMED COORDINATES AND ARE NOT GRID BEARINGS.
2. BASIS FOR SURVEY IS DESCRIPTION, RECORD PLAT, AND MONUMENTATION FOUND IN PLACE.
3. NO UNDERGROUND OR IMPROVEMENTS OR UTILITIES HAVE BEEN LOCATED EXCEPT AS NOTED. THE HORIZONTAL LOCATION OF UNDERGROUND IMPROVEMENTS IS BASED ON THE FLAGGED LOCATION PROVIDED BY THE CONTRACTOR. SOFT DIGS TO CONFIRM SAID LOCATIONS WERE NOT PERFORMED EXCEPT WHERE TOP OF PIPE ELEVATIONS ARE INDICATED.
4. THIS SURVEY IS OF VISIBLE FEATURES ONLY. UNDERGROUND ENCROACHMENTS, IF ANY, WERE NOT LOCATED. GUTTERS, OVERHANGS, WINDOW SILLS, OR UNDERGROUND FOUNDATIONS NOT LOCATED.
5. THE OWNERSHIP OF FENCES, IF ANY EXIST, ON OR NEAR THE PROPERTY LINES IS NOT KNOWN BY THIS SURVEYOR.
6. ADDITIONS, DELETIONS REPRODUCTION OF SURVEY DRAWINGS BY OTHER THAN THE SIGNED PARTY OR PARTIES IS PROHIBITED BY LAW WITHOUT WRITTEN CONSENT OF THE SIGNED PARTY OR PARTIES.
7. THIS SURVEY MAP IS VALID ONLY TO THOSE PERSONS OR ENTITIES NAMED HEREON. COASTAL ENGINEERING ASSOCIATES, INC. WILL ASSUME NO RESPONSIBILITY FOR THE UNAUTHORIZED REPRODUCTION AND/OR REDISTRIBUTION OF THIS SURVEY MAP.
8. THIS SURVEY WAS CONDUCTED WITHOUT THE BENEFIT OF A COMPLETE TITLE REPORT OR TITLE ABSTRACT AND THEREFORE MAY NOT NECESSARILY SHOW ALL RIGHT-OF-WAYS, EASEMENTS OR OTHER ENCUMBRANCES OF RECORD.
9. THIS PROPERTY IS SUBJECT TO ANY DEDICATION, LIMITATIONS, RESERVATIONS, RESTRICTIONS, AND/OR EASEMENTS OF RECORD AND NOT OF RECORD.
10. THE EXPECTED USE OF THE PROPERTY AS DESCRIBED HEREON, AS CLASSIFIED IN THE STANDARDS OF PRACTICE (S-17 OF THE FLORIDA ADMINISTRATIVE CODE), IS "SUBURBAN". THE MINIMUM RELATIVE DISTANCE ACCURACY FOR THIS TYPE OF BOUNDARY SURVEY IS 1 FOOT IN 7,500 FEET. THE ACCURACY OBTAINED BY MEASUREMENT AND CALCULATION OF A CLOSED GEOMETRIC FIGURE WAS FOUND TO MEET OR EXCEED THIS REQUIREMENT.
11. THE PROPERTY DESCRIBED HEREON APPEARS TO BE IN FLOOD ZONE X (AREA DETERMINED TO FALL OUTSIDE OF THE 0.2% CHANCE ANNUAL FLOODPLAIN) AS SCALED FROM THE FLOOD INSURANCE RATE MAP COMMUNITY NUMBER 120110, MAP NUMBER 12053C, PANEL NUMBER 0186-D, EFFECTIVE DATE 02/02/2012.

201104-ESMT-SKT SHEET <b>2 OF 2</b>	DATE	DRAWN BY	SURVEYOR	<b>REUSE OF DOCUMENT</b> THIS DOCUMENT, COMPRISED OF THE INCORPORATED IDEAS AND DESIGNS, AS AN INSTRUMENT OF PROFESSIONAL SERVICE, IS THE PROPERTY OF COASTAL ENGINEERING ASSOCIATES, INC. AND IS NOT TO BE USED, IN WHOLE OR IN PART FOR ANY OTHER PURPOSE WITHOUT THE WRITTEN AUTHORIZATION OF COASTAL ENGINEERING ASSOCIATES, INC.	 Engineering Planning Surveying Environmental Transportation Construction Management 966 Candlelight Boulevard - Brooksville - Florida 34601 (352) 798-8423 - Fax (352) 799-8359 EB-0000142	<b>SURVEYORS CERTIFICATE</b> THIS SURVEY MEETS ALL APPLICABLE REQUIREMENTS OF THE FLORIDA STANDARDS OF PRACTICE AS CONTAINED IN CHAPTER 8A-17 OF THE FLORIDA ADMINISTRATIVE CODE. Digitally signed by <b>Scott M Osborne</b> Date: 2022.09.14 10:00:41 -04'00'	<b>SKETCH ONLY</b> FOR EASEMENT LEGAL DESCRIPTION NOT A BOUNDARY SURVEY	
	19/14/22	SMO	SMO			<b>REVISION</b> DATE      COMMENTS	Scott M Osborne Digitally signed by Scott M Osborne Date: 2022.09.14 10:00:41 -04'00'	PREPARED FOR AND CERTIFIED TO: <b>HERNANDO COUNTY          UTILITIES DEPARTMENT</b>

# EXHIBIT B

## SECTION 35, TOWNSHIP 22 SOUTH, RANGE 18 EAST HERNANDO COUNTY, FLORIDA

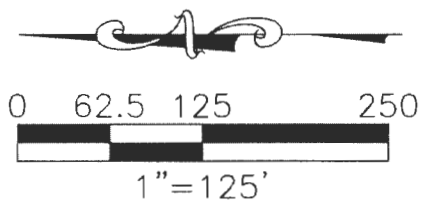
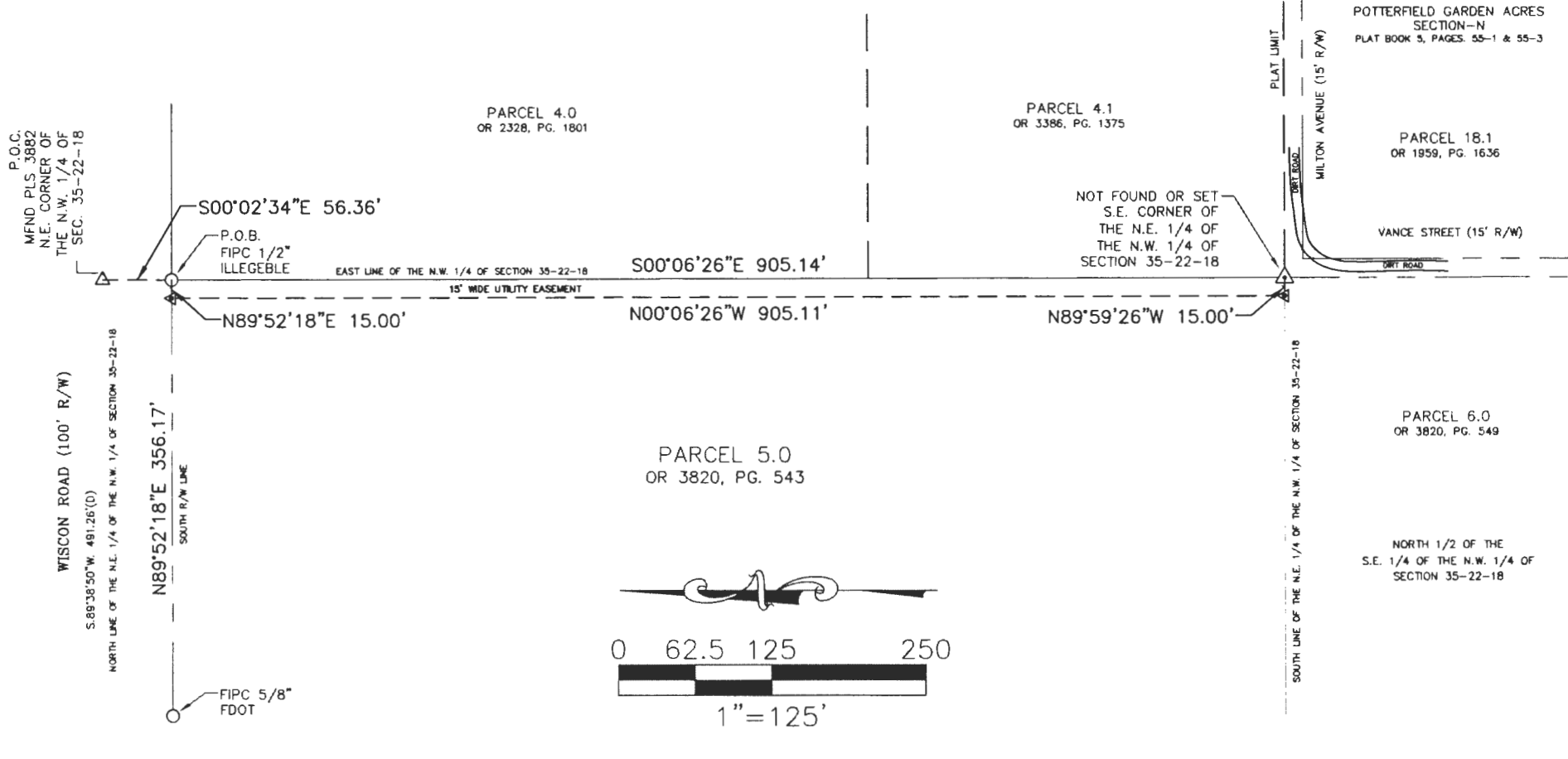

### LEGEND AND ABBREVIATIONS

- |                                |  |
|--------------------------------|--|
| C1 = SEE CURVE TABLE           | P.G. = PAGE                            |
| L1 = SEE LINE TABLE            | FN&D = FOUND NAIL AND DISK             |
| (C) = CALCULATED               | SIPC = SET IRON PIN AND CAP            |
| (R) = RECORD OR PLAT           | FIPC = FOUND IRON PIN AND CAP          |
| R/W = RIGHT OF WAY             | FCM = FOUND CONCRETE MONUMENT          |
| P.O.C. = POINT OF COMMENCEMENT | △ = DESCRIPTIVE POINT                  |
| P.O.B. = POINT OF BEGINNING    | ○ = FOUND CONCRETE MONUMENT (AS SHOWN) |
| SEC = SECTION                  | ○ = FOUND IRON PIN AND CAP (AS SHOWN)  |
| C.L.F. = CHAIN LINK FENCE      | ○ = FOUND NAIL AND DISK (AS SHOWN)     |
| O.R. = OFFICIAL RECORD         | ⊠ = FORCEMAIN GATE VALVE               |

- BEARINGS ARE BASED ON THE WEST LINE OF PARCEL 6.0, ESTABLISHING AN ASSUMED BEARING OF N03°50'31"E AS LISTED IN THE DEED OF RECORD AS RECORDED IN O.R. BOOK 3820, PAGE 549 OF THE PUBLIC RECORDS OF HERNANDO COUNTY, FLORIDA. BEARINGS SHOWN HEREON ARE BASED ON ASSUMED COORDINATES AND ARE NOT GRID BEARINGS.
- BASIS FOR SURVEY IS DESCRIPTION, RECORD PLAT, AND MONUMENTATION FOUND IN PLACE.
- NO UNDERGROUND OR IMPROVEMENTS OR UTILITIES HAVE BEEN LOCATED EXCEPT AS NOTED. THE HORIZONTAL LOCATION OF UNDERGROUND IMPROVEMENTS IS BASED ON THE FLAGGED LOCATION PROVIDED BY THE CONTRACTOR. SOFT DIGS TO CONFIRM SAID LOCATIONS WERE NOT PERFORMED EXCEPT WHERE TOP OF PIPE ELEVATIONS ARE INDICATED.
- THIS SURVEY IS OF VISIBLE FEATURES ONLY. UNDERGROUND ENCROACHMENTS, IF ANY, WERE NOT LOCATED. GUTTERS, OVERHANGS, WINDOW SILLS, OR UNDERGROUND FOUNDATIONS NOT LOCATED.
- THE OWNERSHIP OF FENCES, IF ANY EXIST, ON OR NEAR THE PROPERTY LINES IS NOT KNOWN BY THIS SURVEYOR.
- ADDITIONS, DELETIONS REPRODUCTION OF SURVEY DRAWINGS BY OTHER THAN THE SIGNED PARTY OR PARTIES IS PROHIBITED BY LAW WITHOUT WRITTEN CONSENT OF THE SIGNED PARTY OR PARTIES.
- THIS SURVEY MAP IS VALID ONLY TO THOSE PERSONS OR ENTITIES NAMED HEREON. COASTAL ENGINEERING ASSOCIATES, INC. WILL ASSUME NO RESPONSIBILITY FOR THE UNAUTHORIZED REPRODUCTION AND/OR REDISTRIBUTION OF THIS SURVEY MAP.
- THIS SURVEY WAS CONDUCTED WITHOUT THE BENEFIT OF A COMPLETE TITLE REPORT OR TITLE ABSTRACT AND THEREFORE MAY NOT NECESSARILY SHOW ALL RIGHT-OF-WAYS, EASEMENTS OR OTHER ENCUMBRANCES OF RECORD.
- THIS PROPERTY IS SUBJECT TO ANY DEDICATION, LIMITATIONS, RESERVATIONS, RESTRICTIONS, AND/OR EASEMENTS OF RECORD AND NOT OF RECORD.
- THE EXPECTED USE OF THE PROPERTY AS DESCRIBED HEREON, AS CLASSIFIED IN THE STANDARDS OF PRACTICE (3A-17 OF THE FLORIDA ADMINISTRATIVE CODE), IS "SUBURBAN". THE MINIMUM RELATIVE DISTANCE ACCURACY FOR THIS TYPE OF BOUNDARY SURVEY IS 1 FOOT IN 7,500 FEET. THE ACCURACY OBTAINED BY MEASUREMENT AND CALCULATION OF A CLOSED GEOMETRIC FIGURE WAS FOUND TO MEET OR EXCEED THIS REQUIREMENT.
- THE PROPERTY DESCRIBED HEREON APPEARS TO BE IN FLOOD ZONE X (AREA DETERMINED TO FALL OUTSIDE OF THE 0.2% CHANCE ANNUAL FLOODPLAIN) AS SCALED FROM THE FLOOD INSURANCE RATE MAP COMMUNITY NUMBER 120110, MAP NUMBER 12053C, PANEL NUMBER 0186-D, EFFECTIVE DATE 02/02/2012.

DATE	09/14/22	DRAWN BY	SMD	SURVEYOR	SMD
	REVISION				
	DATE	COMMENTS			

**REUSE OF DOCUMENT**

THIS DOCUMENT, COMPRISED OF THE INCORPORATED IDEAS AND DESIGNS, AS AN INSTRUMENT OF PROFESSIONAL SERVICE, IS THE PROPERTY OF COASTAL ENGINEERING ASSOCIATES, INC. AND IS NOT TO BE USED, IN WHOLE OR IN PART FOR ANY OTHER PURPOSE WITHOUT THE WRITTEN AUTHORIZATION OF COASTAL ENGINEERING ASSOCIATES, INC.

Engineering  
Planning  
Surveying  
Environmental  
Transportation  
Construction Management

966 Candlelight Boulevard - Brooksville - Florida 34601  
(352) 796-9423 - Fax (352) 799-8359  
EB-0000142

**SCOTT M OSBORNE**

DATE SIGNED  
2022.09.14 10:05:09 -04:00

Professionally signed by Scott M Osborne

DATE SIGNED  
2022.09.14 10:05:09 -04:00

Professionally signed by Scott M Osborne

**SKETCH ONLY  
FOR EASEMENT LEGAL DESCRIPTION  
NOT A BOUNDARY SURVEY**

PREPARED FOR AND CERTIFIED TO:

**HERNANDO COUNTY  
UTILITIES DEPARTMENT**

20104-ESMT-SKT  
1 OF 2 SHEET