

TRANSPORTATION ANALYSIS

US 19 and Spring Hill Drive - NEC

Prepared for:

Brightwork Real Estate



Transportation Analysis

US 19 and Spring Hill Drive - NEC

September 2021
August 2022
November 2022
January 2023

Prepared for:
Brightwork Real Estate

Prepared by:
Palm Traffic
400 North Tampa Street, 15th Floor
Tampa, FL 33602
Ph: (813) 296-2595

Project No. T21069



**Vicki L
Castro**

Digitally signed
by Vicki L Castro
Date: 2023.01.04
09:43:26 -05'00'

Vicki L. Castro, P.E.
P.E. No. 47128

TABLE OF CONTENTS

Introduction	1
Project Description	1
Estimated Daily Project Traffic.....	4
Estimated AM Project Traffic	4
Estimated PM Project Traffic.....	4
Project Trip Distribution/Assignment.....	8
Budgeted Improvements	8
Study Area.....	26
Adjacent Roadways.....	26
Buildout	26
Background Traffic.....	28
Intersection Analysis	48

LIST OF FIGURES

Figure 1. Project Location.....	3
Figure 2. Scenario 1 – Project Traffic – AM Peak Hour	10
Figure 3. Scenario 1 – Project Traffic – PM Peak Hour	11
Figure 4. Scenario 2 – Project Traffic – AM Peak Hour	12
Figure 5. Scenario 2 – Project Traffic – PM Peak Hour	13
Figure 6. Scenario 3 – Project Traffic – AM Peak Hour	14
Figure 7. Scenario 3 – Project Traffic – PM Peak Hour	15
Figure 8. Scenario 4 – Project Traffic – AM Peak Hour	16
Figure 9. Scenario 4 – Project Traffic – PM Peak Hour	17
Figure 10. Scenario 5 – Project Traffic – AM Peak Hour	18
Figure 11. Scenario 5 – Project Traffic – PM Peak Hour	19
Figure 12. Scenario 6 – Project Traffic – AM Peak Hour	20
Figure 13. Scenario 6 – Project Traffic – PM Peak Hour	21
Figure 14. Scenario 7 – Project Traffic – AM Peak Hour	22
Figure 15. Scenario 7 – Project Traffic – PM Peak Hour	23
Figure 16. Scenario 8 – Project Traffic – AM Peak Hour	24
Figure 17. Scenario 8 – Project Traffic – PM Peak Hour	25
Figure 18. Existing Traffic.....	29

Figure 19. Peak Season Traffic	30
Figure 20. Background Traffic	31
Figure 21. Scenario 1 – Background Plus Project Traffic – AM Peak Hour	32
Figure 22. Scenario 1 – Background Plus Project Traffic – PM Peak Hour	33
Figure 23. Scenario 2 – Background Plus Project Traffic – AM Peak Hour	34
Figure 24. Scenario 2 – Background Plus Project Traffic – PM Peak Hour	35
Figure 25. Scenario 3 – Background Plus Project Traffic – AM Peak Hour	36
Figure 26. Scenario 3 – Background Plus Project Traffic – PM Peak Hour	37
Figure 27. Scenario 4 – Background Plus Project Traffic – AM Peak Hour	38
Figure 28. Scenario 4 – Background Plus Project Traffic – PM Peak Hour	39
Figure 29. Scenario 5 – Background Plus Project Traffic – AM Peak Hour	40
Figure 30. Scenario 5 – Background Plus Project Traffic – PM Peak Hour	41
Figure 31. Scenario 6 – Background Plus Project Traffic – AM Peak Hour	42
Figure 32. Scenario 6 – Background Plus Project Traffic – PM Peak Hour	43
Figure 33. Scenario 7 – Background Plus Project Traffic – AM Peak Hour	44
Figure 34. Scenario 7 – Background Plus Project Traffic – PM Peak Hour	45
Figure 35. Scenario 8 – Background Plus Project Traffic – AM Peak Hour	46
Figure 36. Scenario 8 – Background Plus Project Traffic – PM Peak Hour	47

LIST OF TABLES

Table 1. Estimated Daily Project Traffic.....	5
Table 2. AM Peak Hour Project Traffic	6
Table 3. PM Peak Hour Project Traffic.....	7
Table 4. Estimated New Peak Hour Project Traffic Distribution.....	9
Table 5. Study Area Determination.....	27
Table 6. Estimated Intersection Volume to Capacity – Scenario 1	49
Table 7. Estimated Intersection Volume to Capacity – Scenario 2.....	50
Table 8. Estimated Intersection Volume to Capacity – Scenario 3.....	51
Table 9. Estimated Intersection Volume to Capacity – Scenario 4.....	52
Table 10. Estimated Intersection Volume to Capacity – Scenario 5	53
Table 11. Estimated Intersection Volume to Capacity – Scenario 6	54
Table 12. Estimated Intersection Volume to Capacity – Scenario 7	55
Table 13. Estimated Intersection Volume to Capacity – Scenario 8	56

LIST OF APPENDICES

Conceptual Site Plan
Trip Generation
ITE Passerby Rates
Turning Movement Counts
FDOT Seasonal Adjustment Factors
FDOT Historical Counts
FDOT Generalized Level of Service Handbook Tables
Signal Timings
Intersection Analysis

INTRODUCTION

The purpose of this report is to provide the Transportation Analysis for the proposed development of the property located east of US 19 and north of Spring Hill Drive in Hernando County, Florida, as shown in Figure 1.

PROJECT DESCRIPTION

The property is currently vacant. The proposed project will consist of a mix of commercial uses on six (6) or seven (7) outparcels. The out parcels exact uses are unknown at this time, but the following represent a potential mix of uses:

- 2,500 square foot Fast Food Restaurant with Drive-Through
- 5,000 square foot Medical/Dental Office
- 5,000 square foot Medical/Dental Office
- 6,000 square foot High Turnover Restaurant
- 7,000 square foot Strip Retail Plaza.

Eight scenarios of access layouts are being evaluated in this report.

Scenario 1:

- One (1) right-in/right-out access to US 19
- One (1) left-in/left-out/right-in/right-out access to US 19
- Two (2) full accesses to Pinehurst Drive.

Scenario 2:

- One (1) right-in/right-out access to US 19
- One (1) left-in/left-out/right-in/right-out access to US 19.

Scenario 3:

- One (1) right-in/right-out access to US 19
- One (1) left-in/left-out/right-in/right-out access to US 19
- Two (2) right-in/right-out accesses to Pinehurst Drive.

Scenario 4:

- One (1) right-in/right-out access to US 19
- One (1) left-in/left-out/right-in/right-out access to US 19
- Two (2) left-in/right-in/right-out accesses to Pinehurst Drive.

Scenario 5:

- One (1) right-in/right-out access to US 19
- One (1) left-in/left-out/right-in/right-out access to US 19
- Connection to the frontage road to the north.

Scenario 6:

- One (1) right-in/right-out access to US 19
- One (1) left-in/left-out/right-in/right-out access to US 19
- Two (2) left-in/right-in/right-out accesses to Pinehurst Drive
- Connection to the frontage road to the north.

Scenario 7:

- One (1) right-in/right-out access to US 19
- One (1) left-in/left-out/right-in/right-out access to US 19
- Two (2) full accesses to Pinehurst Drive
- Connection to the frontage road to the north.

Scenario 8:

- One (1) right-in/right-out access to US 19
- One (1) left-in/left-out/right-in/right-out access to US 19
- Two (2) right-in/right-out accesses to Pinehurst Drive
- Connection to the frontage road to the north.

A conceptual site plan is included in the Appendix of this report.

Figure 1. Project Location

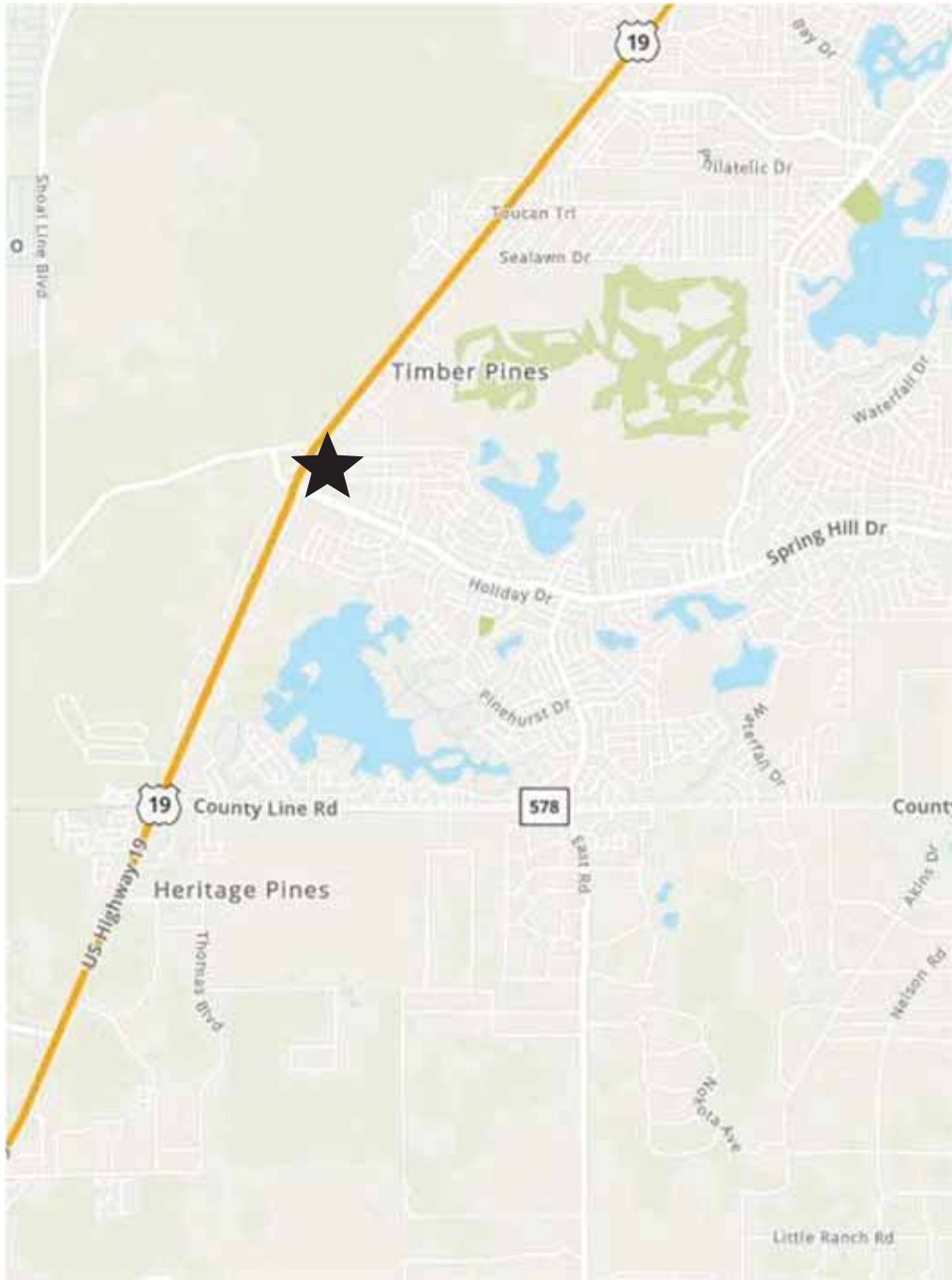

ESTIMATED DAILY PROJECT TRAFFIC

The trip rates utilized in this report were obtained from the latest computerized version of OTISS which utilizes the Institute of Transportation Engineers (ITE) Trip Generation, 11th Edition, 2021, as its database. Based on these trip rates, it is estimated that the proposed project will attract approximately 9,468 daily trip ends, as shown in Table 1.

Studies contained in the ITE Trip Generation, 11th Edition, indicate that a percentage of the project trips already exist on the adjacent roadways - passerby capture. Therefore, the new daily trip ends attracted to the proposed project would be 3,269 trip ends, as shown in Table 1.

ESTIMATED AM PROJECT TRAFFIC

Again, based on data contained in the ITE Trip Generation, 11th Edition, the proposed project would attract approximately 850 trip ends during the AM peak hour with 440 inbound and 410 outbound, as shown in Table 2.

As previously stated, studies contained in the ITE Trip Generation, 11th Edition, indicate that a percentage of the project trips already exist on the adjacent roadways - passerby capture. Therefore, the new AM peak hour trip ends attracted to the proposed project would be 282 trip ends with 155 inbound and 127 outbound, as shown in Table 2.

ESTIMATED PM PROJECT TRAFFIC

Again, based on data contained in the ITE Trip Generation, 11th Edition, the proposed project would attract approximately 769 trip ends during the PM peak hour with 385 inbound and 384 outbound, as shown in Table 3.

As previously stated, studies contained in the ITE Trip Generation, 11th Edition, indicate that a percentage of the projects trips already exist on the adjacent roadways - passerby capture. Therefore, the new PM peak hour trip ends attracted to the proposed project would be 272 trip ends with 133 inbound and 139 outbound, as shown in Table 3.

Table 1. Estimated Daily Project Traffic

<u>Land Use</u>	<u>ITE LUC</u>	<u>Size</u>	<u>Daily Trip Ends (1)</u>	<u>Passerby Capture (1)</u>	<u>New Daily Trip Ends</u>
Conv Store/Gas	945	20 FP	6,915	5,186	1,729
Fast Food Restaurant	934	2,500 SF	1,169	585	584
Medical Office	720	5,000 SF	180	0	180
Medical Office	720	5,000 SF	180	0	180
High Turnover Rest.	932	6,000 SF	643	276	367
Strip Retail Plaza	822	7,000 SF	<u>381</u>	<u>152</u>	<u>229</u>
		Total	9,468	6,199	3,269

(1) Source: ITE Trip Generation, 11th Edition, 2021.

Table 2. AM Peak Hour Project Traffic

<u>Land Use</u>	<u>ITE LUC</u>	<u>Size</u>	<u>AM Peak Hour Trip Ends (1)</u>			<u>Passerby Capture (1)</u>			<u>New AM Peak Hour Trip Ends</u>		
			<u>In</u>	<u>Out</u>	<u>Total</u>	<u>In</u>	<u>Out</u>	<u>Total</u>	<u>In</u>	<u>Out</u>	<u>Total</u>
Conv Store/Gas	945	20 FP	316	316	632	240	240	480	76	76	152
Fast Food Restaurant	934	2,500 SF	57	55	112	28	28	56	29	27	56
Medical Office	720	5,000 SF	13	3	16	0	0	0	13	3	16
Medical Office	720	5,000 SF	13	3	16	0	0	0	13	3	16
High Turnover Rest.	932	6,000 SF	31	26	57	13	12	25	18	14	32
Strip Retail Plaza	822	7,000 SF	<u>10</u>	<u>7</u>	<u>17</u>	<u>4</u>	<u>3</u>	<u>7</u>	<u>6</u>	<u>4</u>	<u>10</u>
Total			440	410	850	285	283	568	155	127	282

(1) Source: ITE Trip Generation, 11th Edition, 2021.

Table 3. PM Peak Hour Project Traffic

<u>Land Use</u>	<u>ITE LUC</u>	<u>Size</u>	<u>PM Peak Hour Trip Ends (1)</u>			<u>Passerby Capture (1)</u>			<u>New PM Peak Hour Trip Ends</u>		
			<u>In</u>	<u>Out</u>	<u>Total</u>	<u>In</u>	<u>Out</u>	<u>Total</u>	<u>In</u>	<u>Out</u>	<u>Total</u>
Conv Store/Gas	945	20 FP	269	269	538	202	202	404	67	67	134
Fast Food Restaurant	934	2,500 SF	43	40	83	24	22	46	19	18	37
Medical Office	720	5,000 SF	5	12	17	0	0	0	5	12	17
Medical Office	720	5,000 SF	5	12	17	0	0	0	5	12	17
High Turnover Rest.	932	6,000 SF	33	21	54	14	9	23	19	12	31
Strip Retail Plaza	822	7,000 SF	<u>30</u>	<u>30</u>	<u>60</u>	<u>12</u>	<u>12</u>	<u>24</u>	<u>18</u>	<u>18</u>	<u>36</u>
Total			385	384	769	252	245	497	133	139	272

(1) Source: ITE Trip Generation, 11th Edition, 2021.

PROJECT TRIP DISTRIBUTION/ASSIGNMENT

The following distribution of the new AM and PM peak hour trip ends was based on the existing traffic and development patterns with hand assignment to the local network:

- 25% to and from the north (via US 19)
- 25% to and from the south (via US 19)
- 40% to and from the east (via Spring Hill Drive)
- 10% to and from the west (via Spring Hill Drive).

Table 4 shows the distribution of the new AM and PM peak hour project trip ends. Figure 2 and Figure 3 illustrate the AM and PM peak hour trip ends for Access Scenario 1, respectively. Figure 4 and Figure 5 illustrate the AM and PM peak hour trip ends for Access Scenario 2, respectively. Figure 6 and Figure 7 illustrate the AM and PM peak hour trip ends for Access Scenario 3, respectively. Figure 8 and Figure 11 illustrate the AM and PM peak hour trip ends for Access Scenario 4, respectively. Figure 10 and Figure 11 illustrate the AM and PM peak hour trip ends for Access Scenario 5, respectively. Figure 12 and Figure 13 illustrate the AM and PM peak hour trip ends for Access Scenario 6, respectively. Figure 14 and Figure 15 illustrate the AM and PM peak hour trip ends for Access Scenario 7, respectively. Figure 16 and Figure 17 illustrate the AM and PM peak hour trip ends for Access Scenario 8, respectively.

BUDGETED IMPROVEMENTS

According to the FDOT Work Program and the Hernando County Capital Improvement Program, there are no capacity adding projects budgeted within the vicinity of the project.

Table 4. Estimated New Peak Hour Project Traffic Distribution

<u>Time Period</u>	<u>North (25%)</u>		<u>South (25%)</u>		<u>East (40%)</u>		<u>West (10%)</u>		<u>Total</u>	
	<u>In</u>	<u>Out</u>	<u>In</u>	<u>Out</u>	<u>In</u>	<u>Out</u>	<u>In</u>	<u>Out</u>	<u>In</u>	<u>Out</u>
AM	39	32	39	32	62	51	15	12	155	127
PM	33	35	33	35	53	55	14	14	133	139

Figure 2. Scenario 1 – Project Traffic – AM Peak Hour

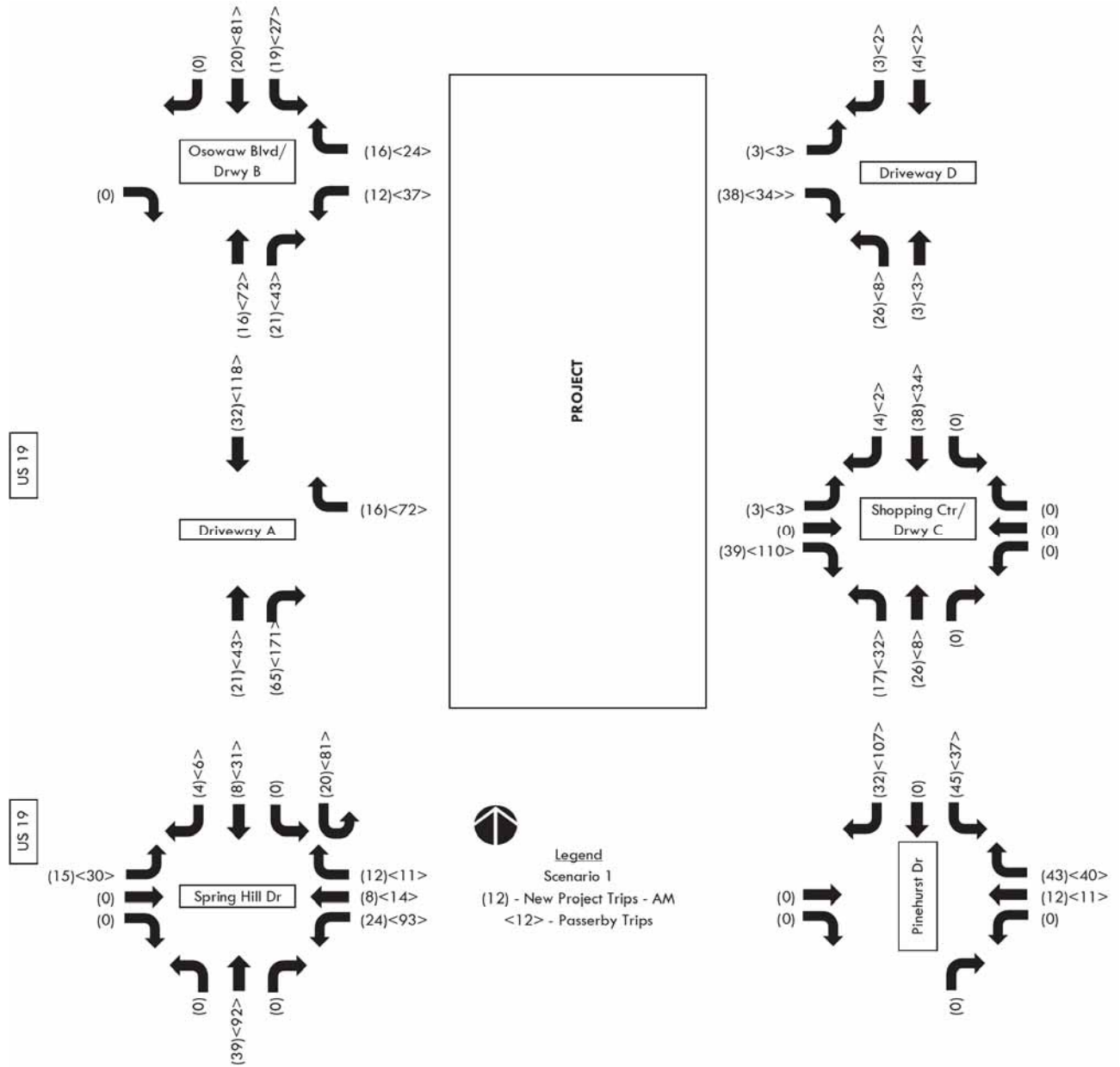

Figure 3. Scenario 1 – Project Traffic – PM Peak Hour

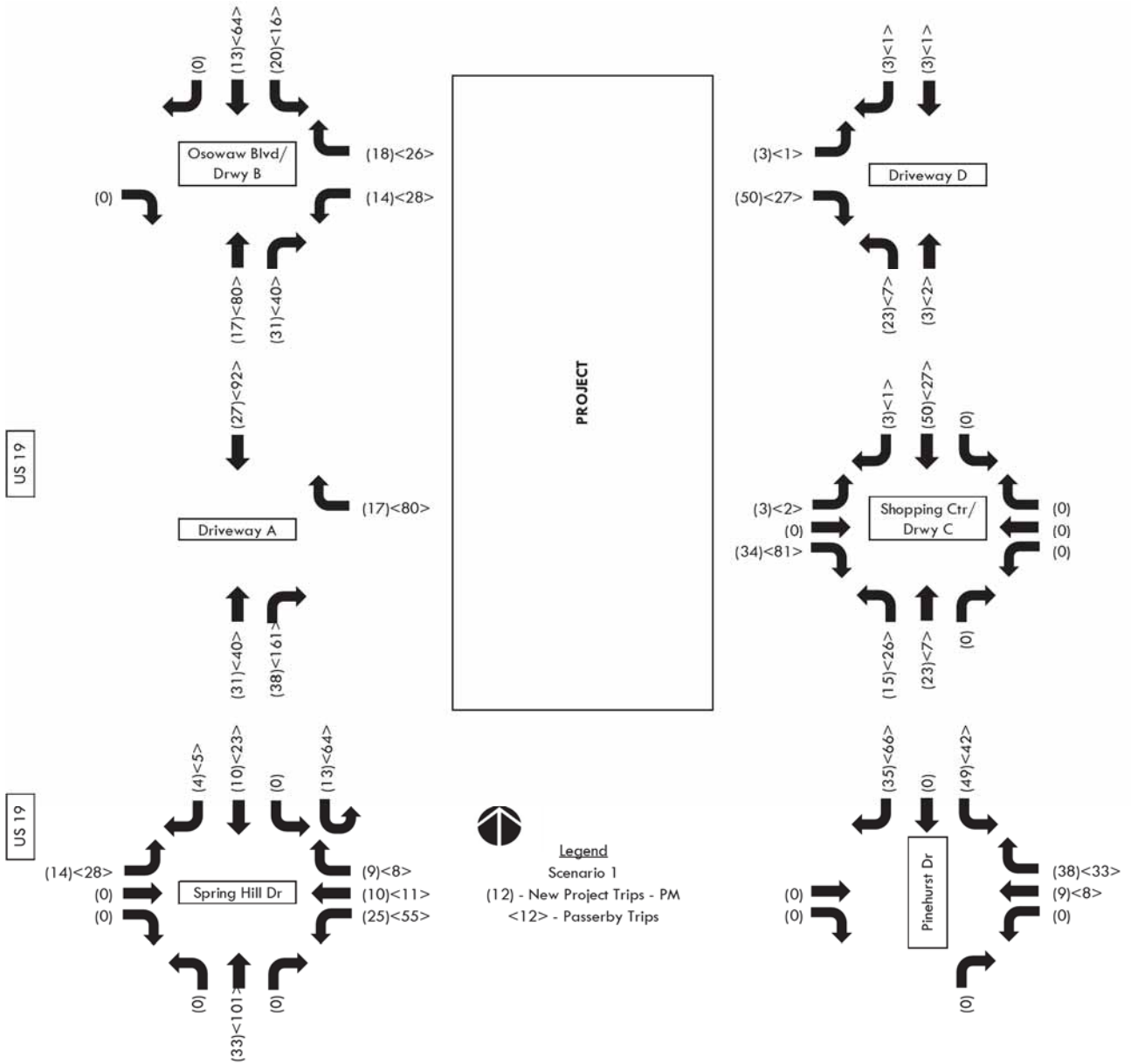

Figure 4. Scenario 2 – Project Traffic – AM Peak Hour

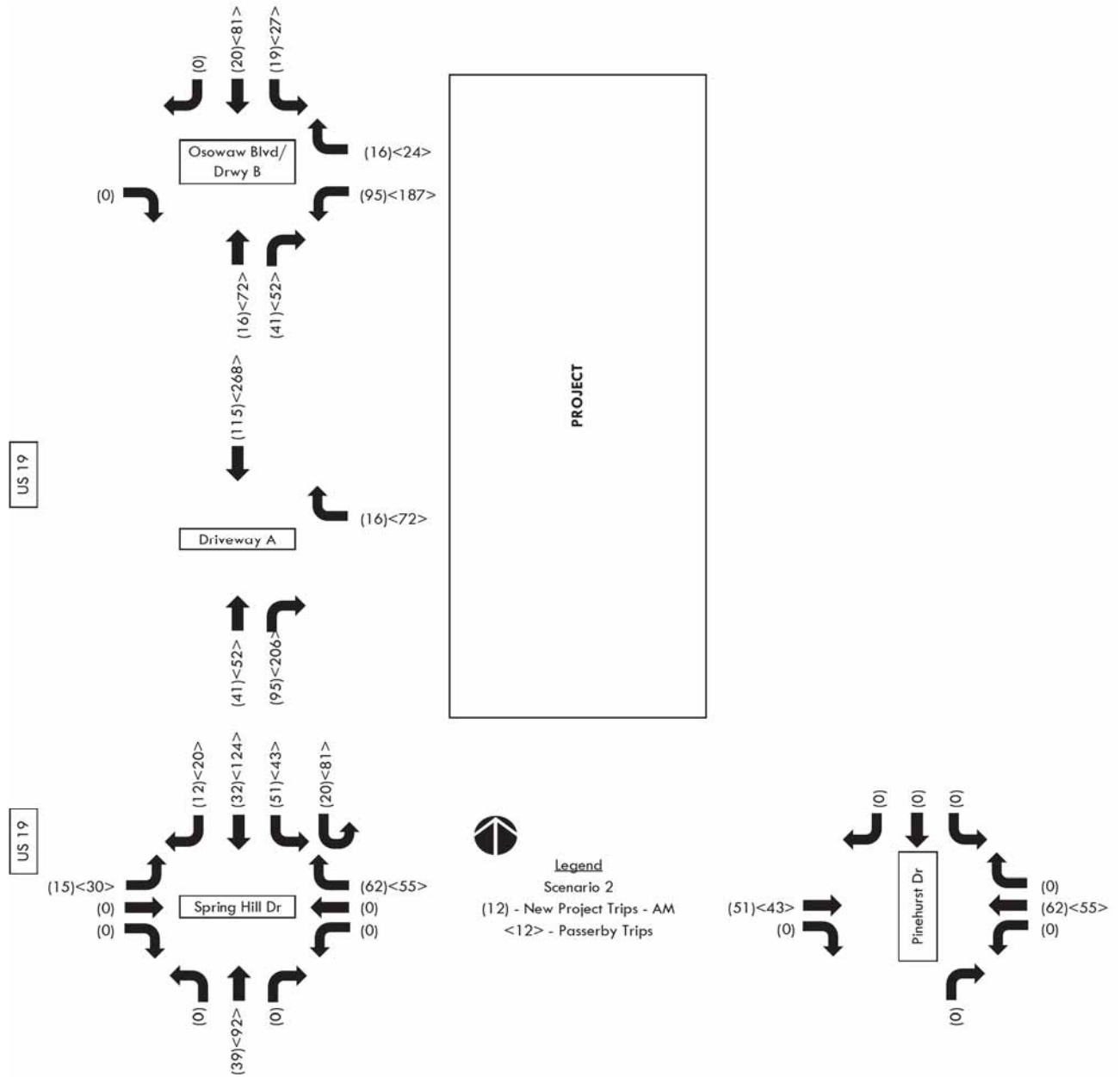

Figure 5. Scenario 2 – Project Traffic – PM Peak Hour

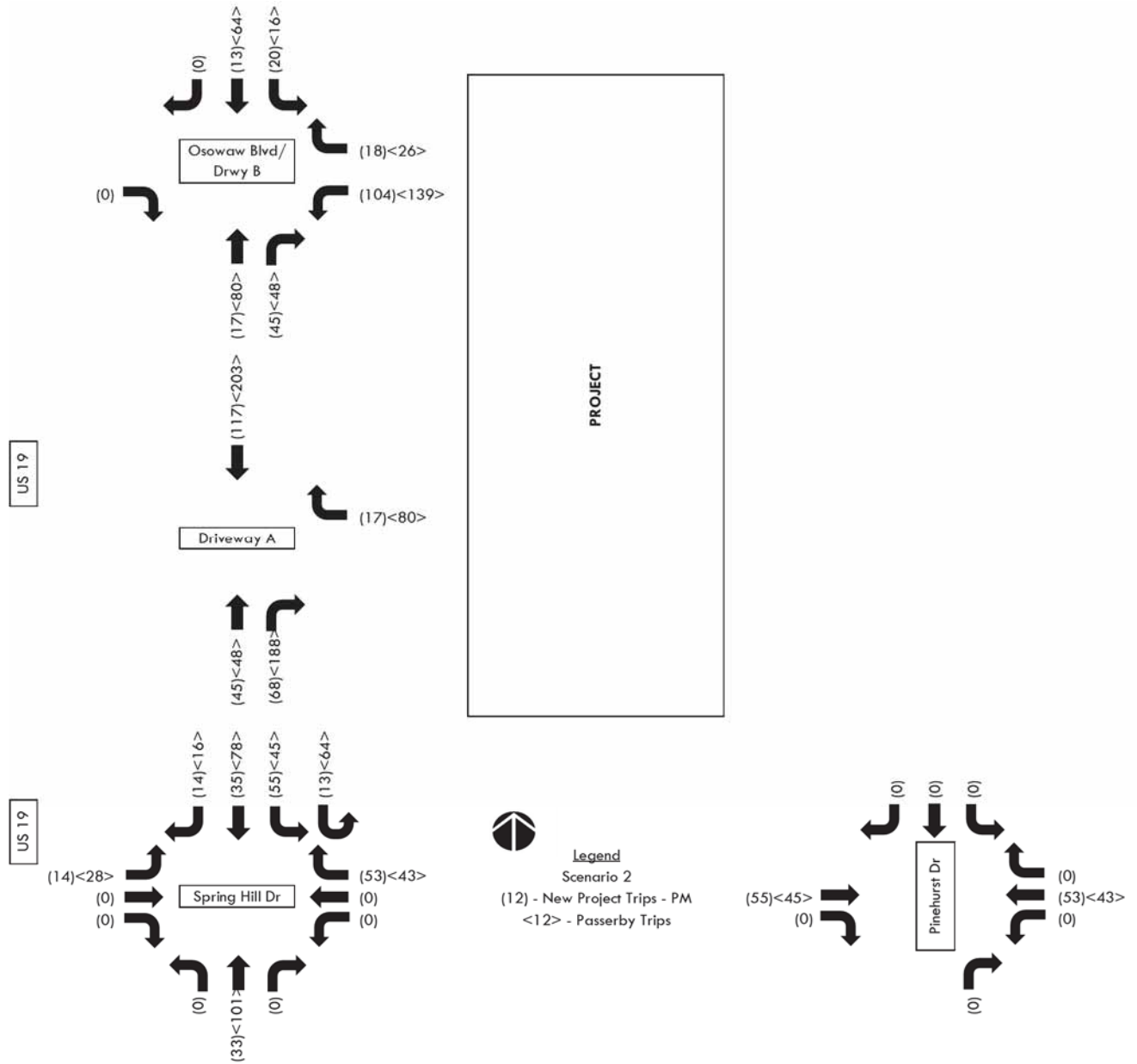

Figure 6. Scenario 3 – Project Traffic – AM Peak Hour

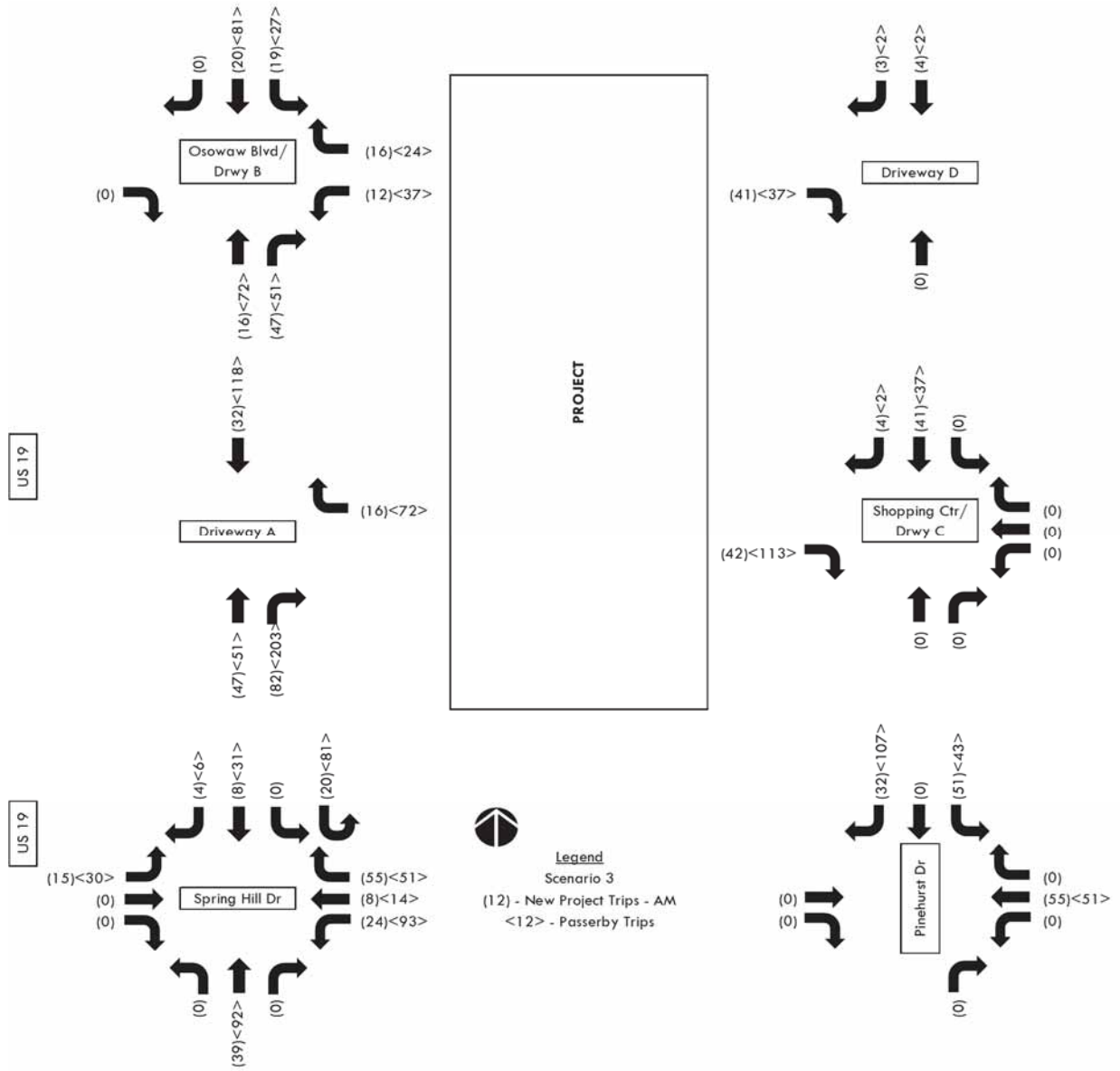

Figure 7. Scenario 3 – Project Traffic – PM Peak Hour

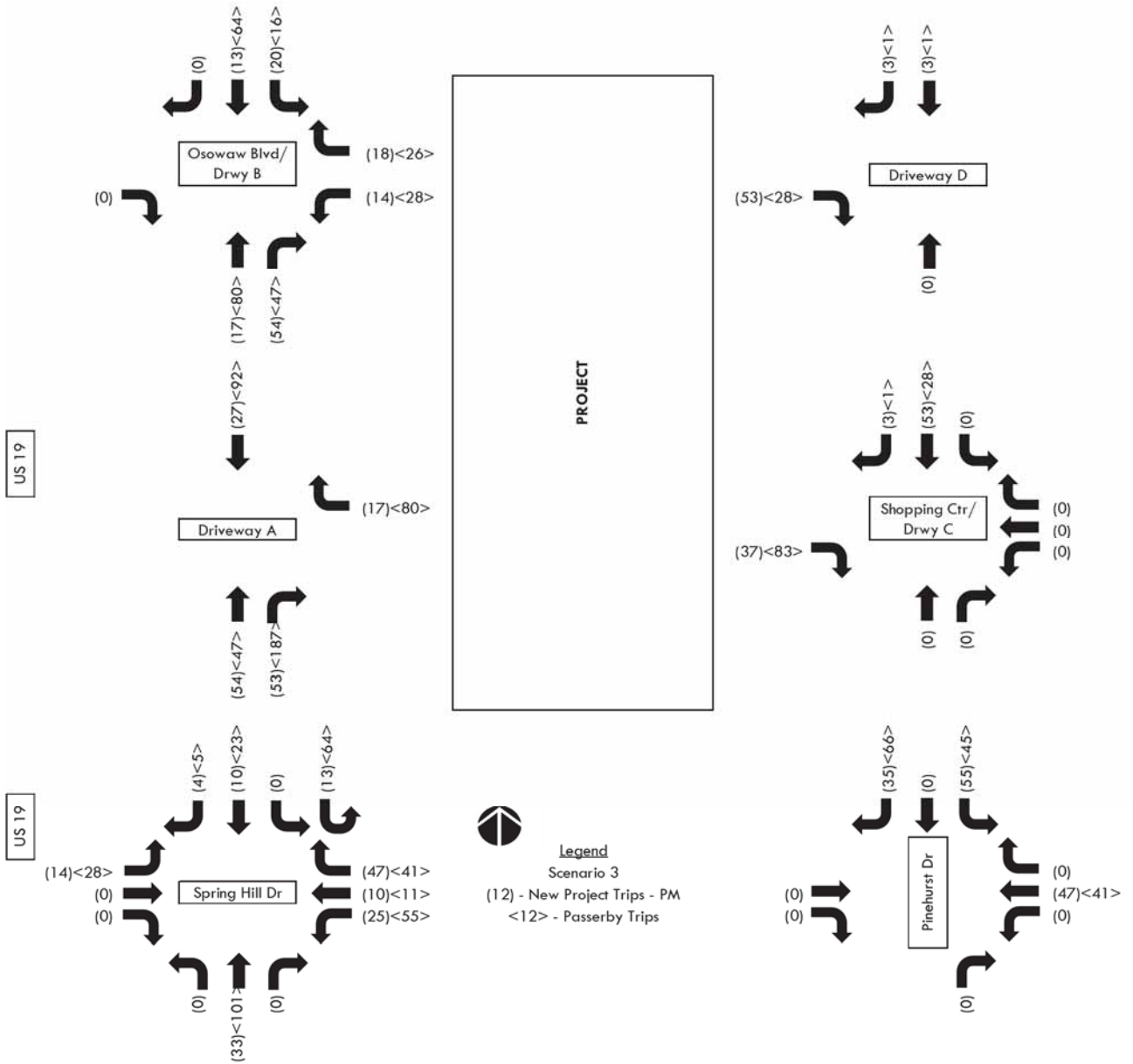

Figure 8. Scenario 4 – Project Traffic – AM Peak Hour

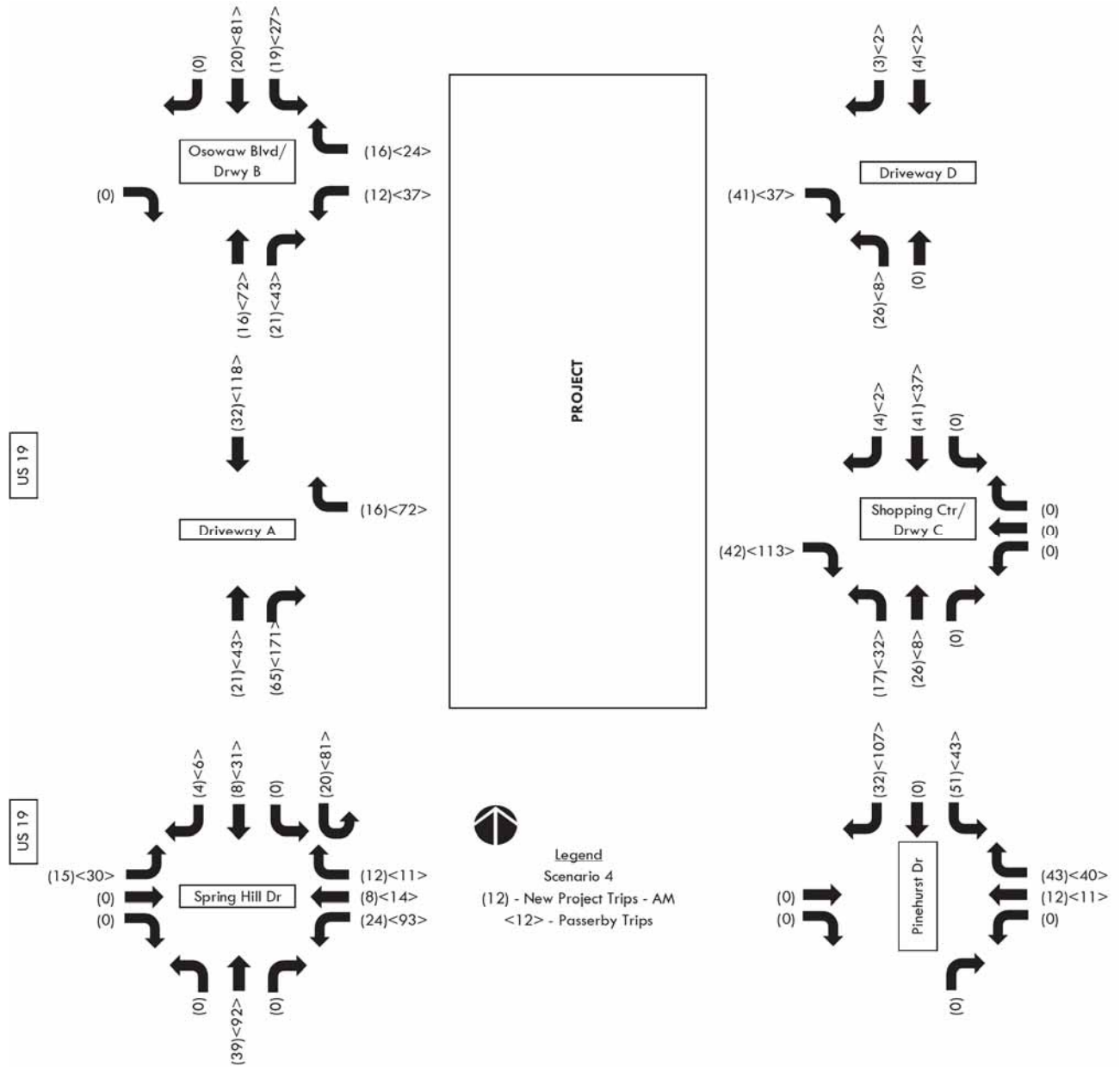

Figure 9. Scenario 4 – Project Traffic – PM Peak Hour

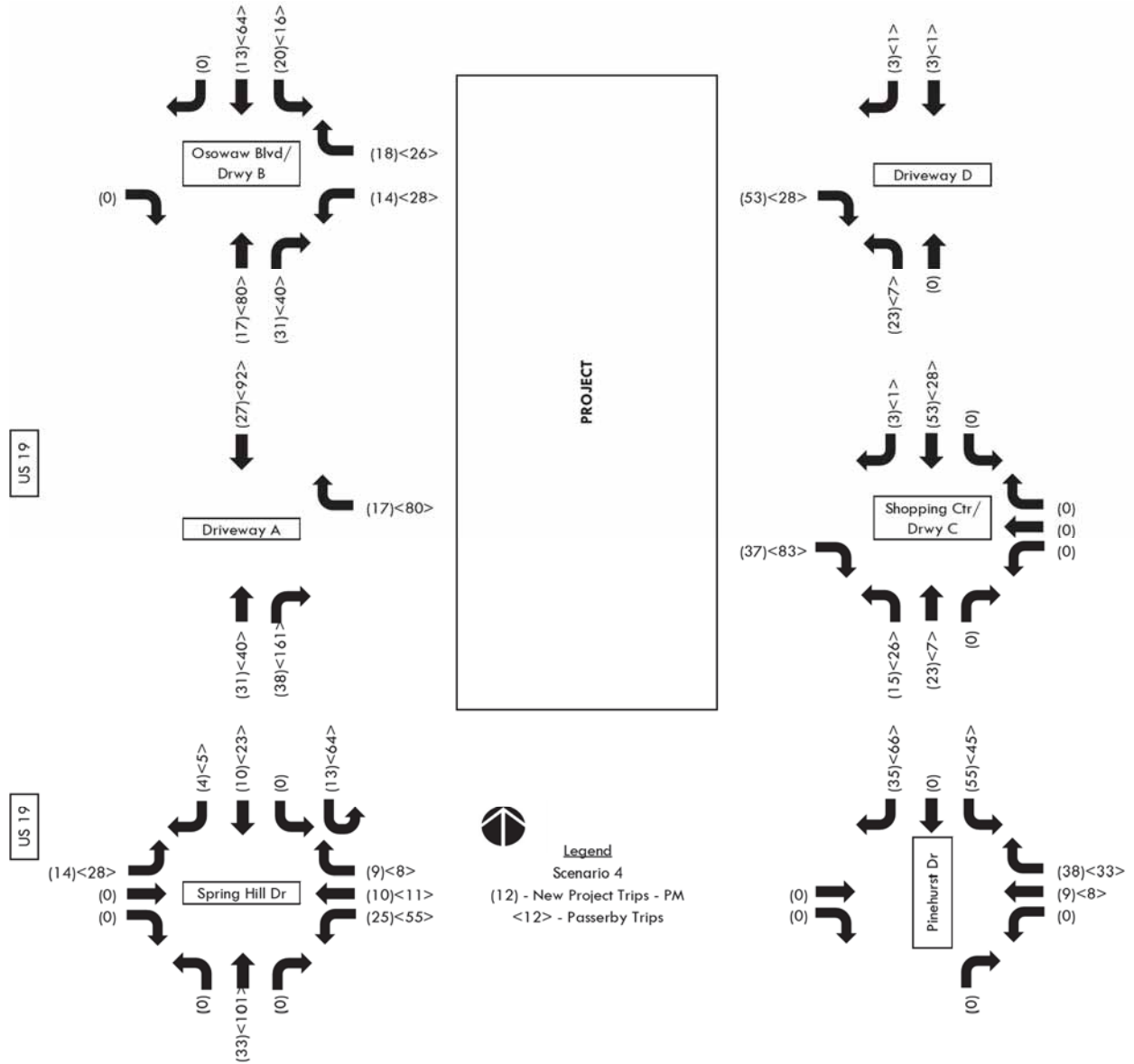

Figure 10. Scenario 5 – Project Traffic – AM Peak Hour

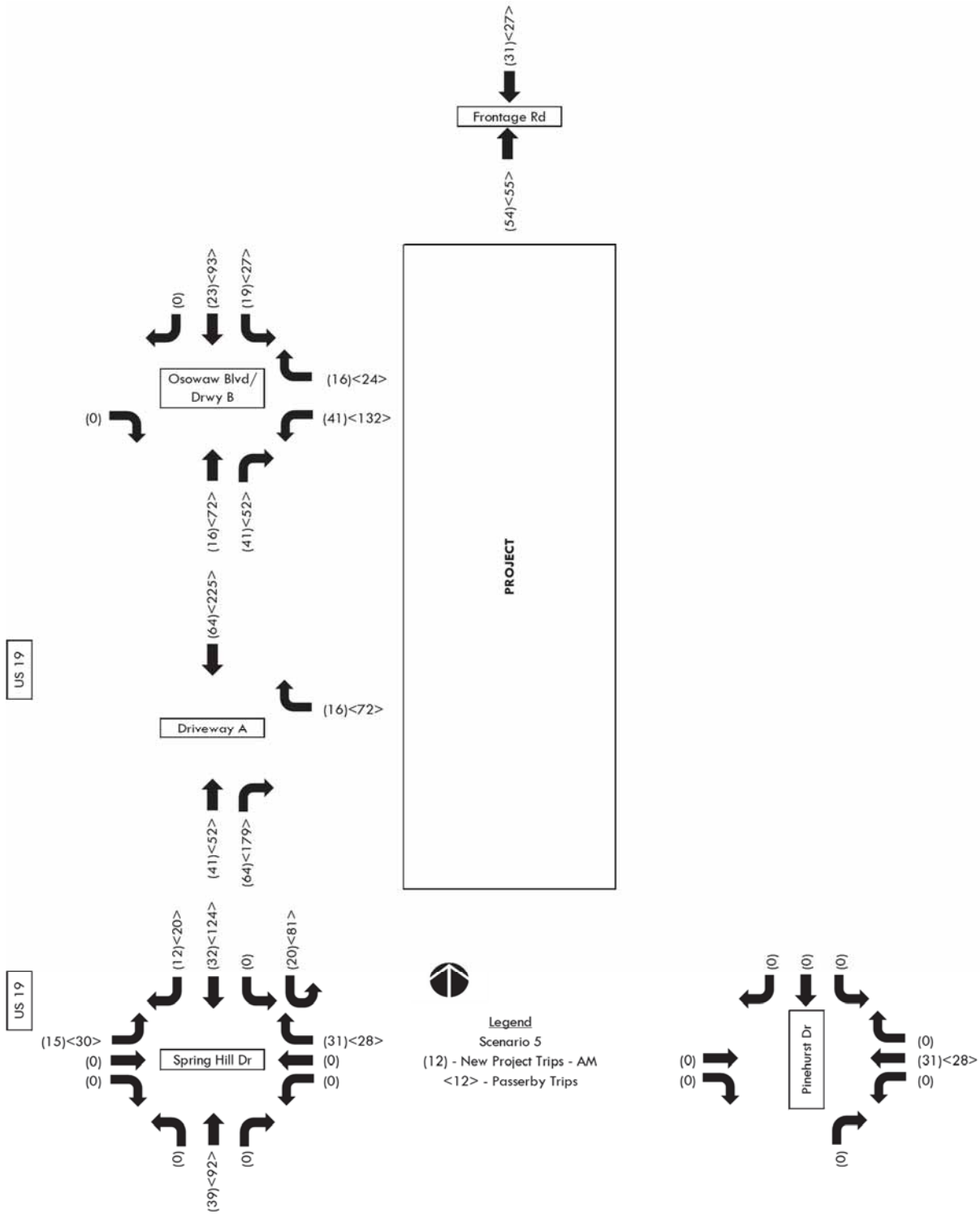

Figure 11. Scenario 5 – Project Traffic – PM Peak Hour

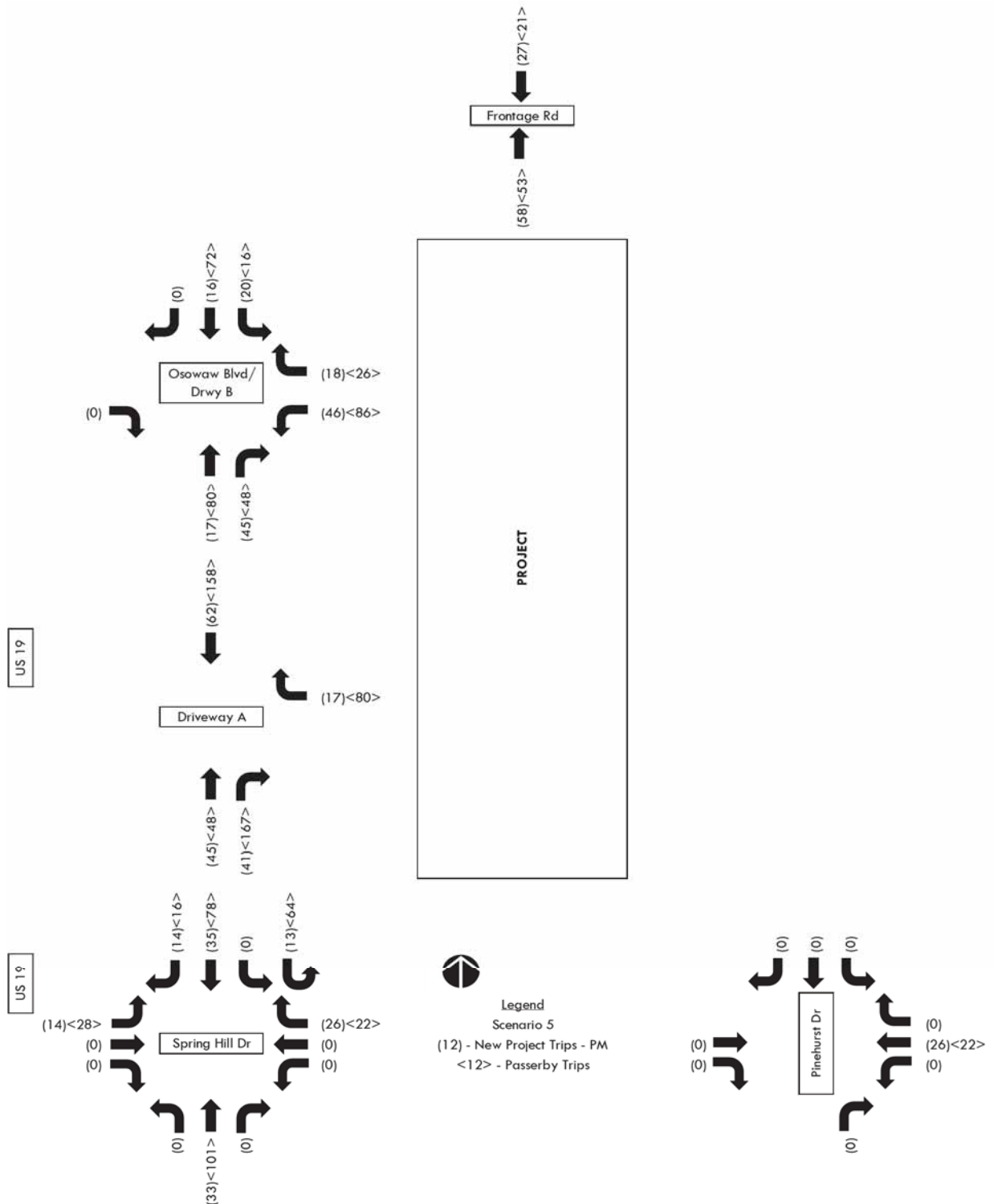

Figure 12. Scenario 6 – Project Traffic – AM Peak Hour

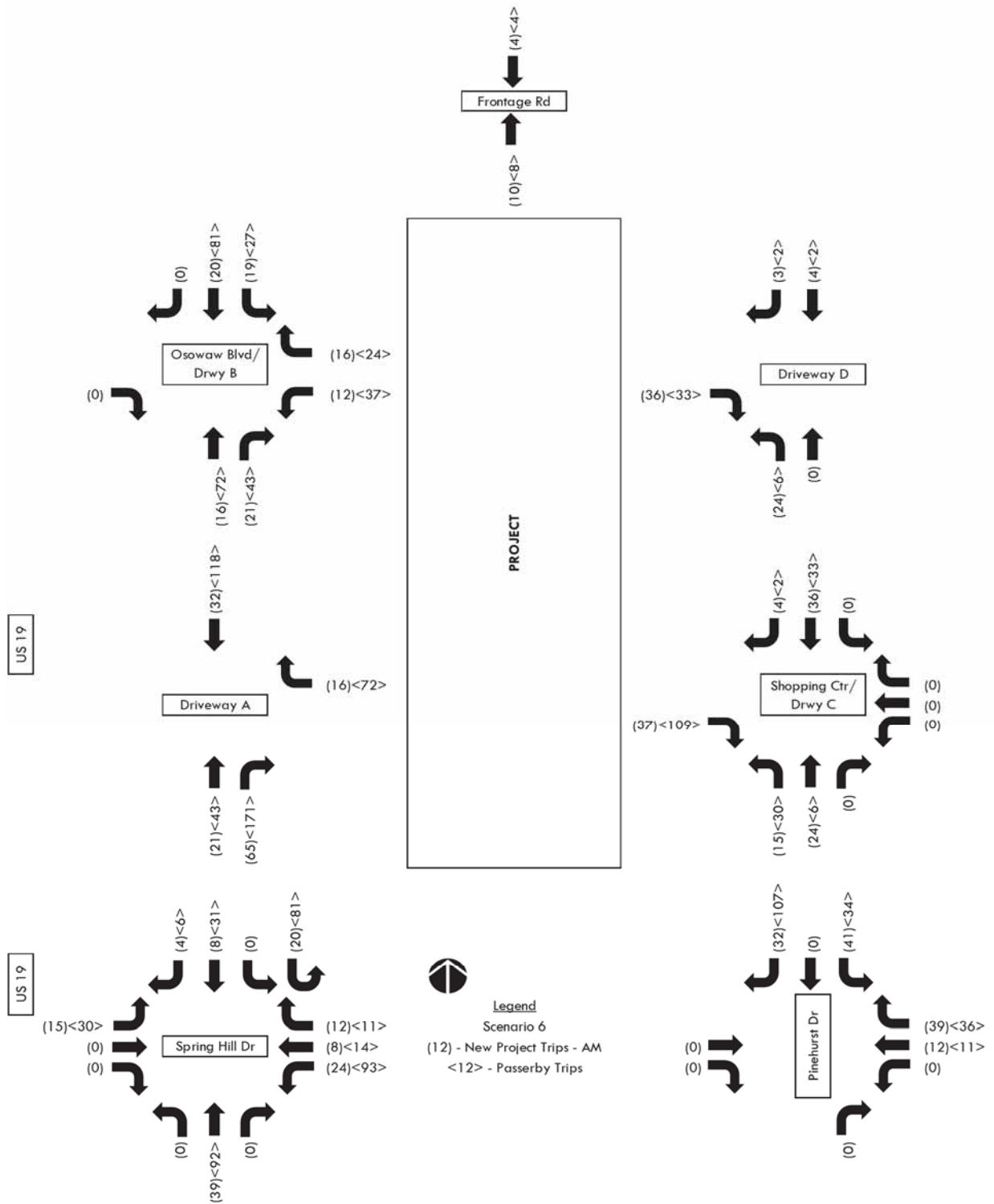

Figure 13. Scenario 6 – Project Traffic – PM Peak Hour

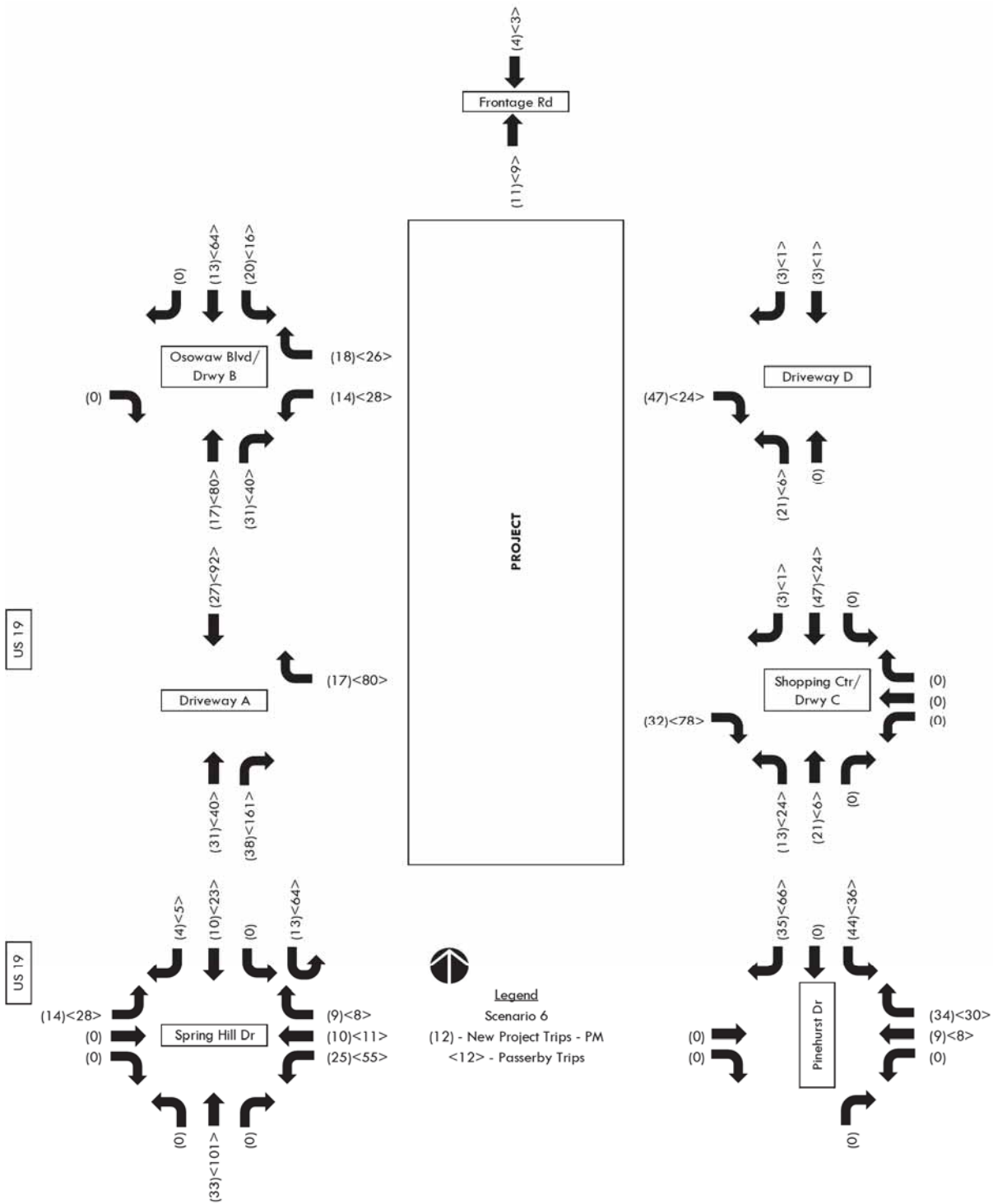

Figure 14. Scenario 7 – Project Traffic – AM Peak Hour

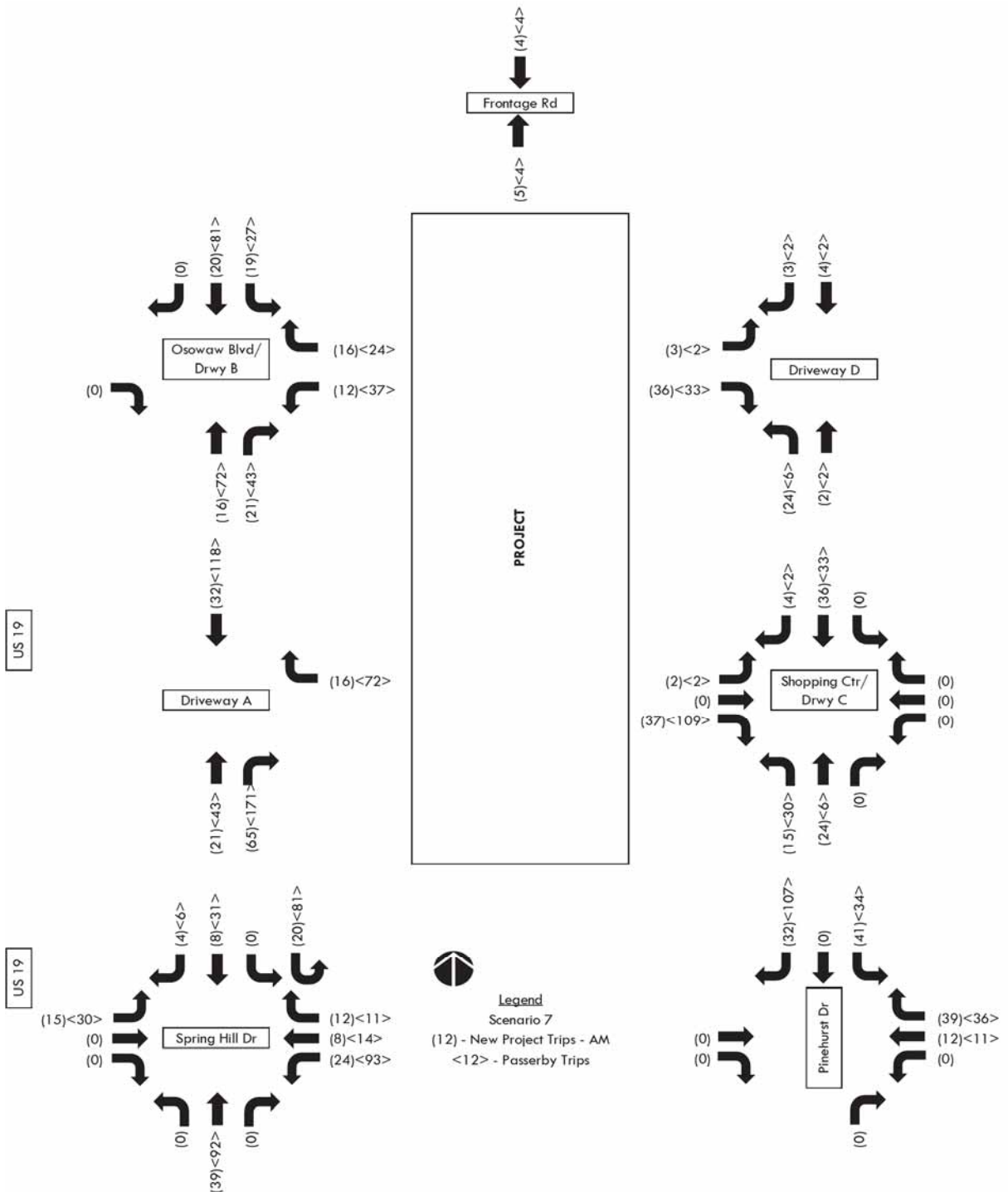

Figure 15. Scenario 7 – Project Traffic – PM Peak Hour

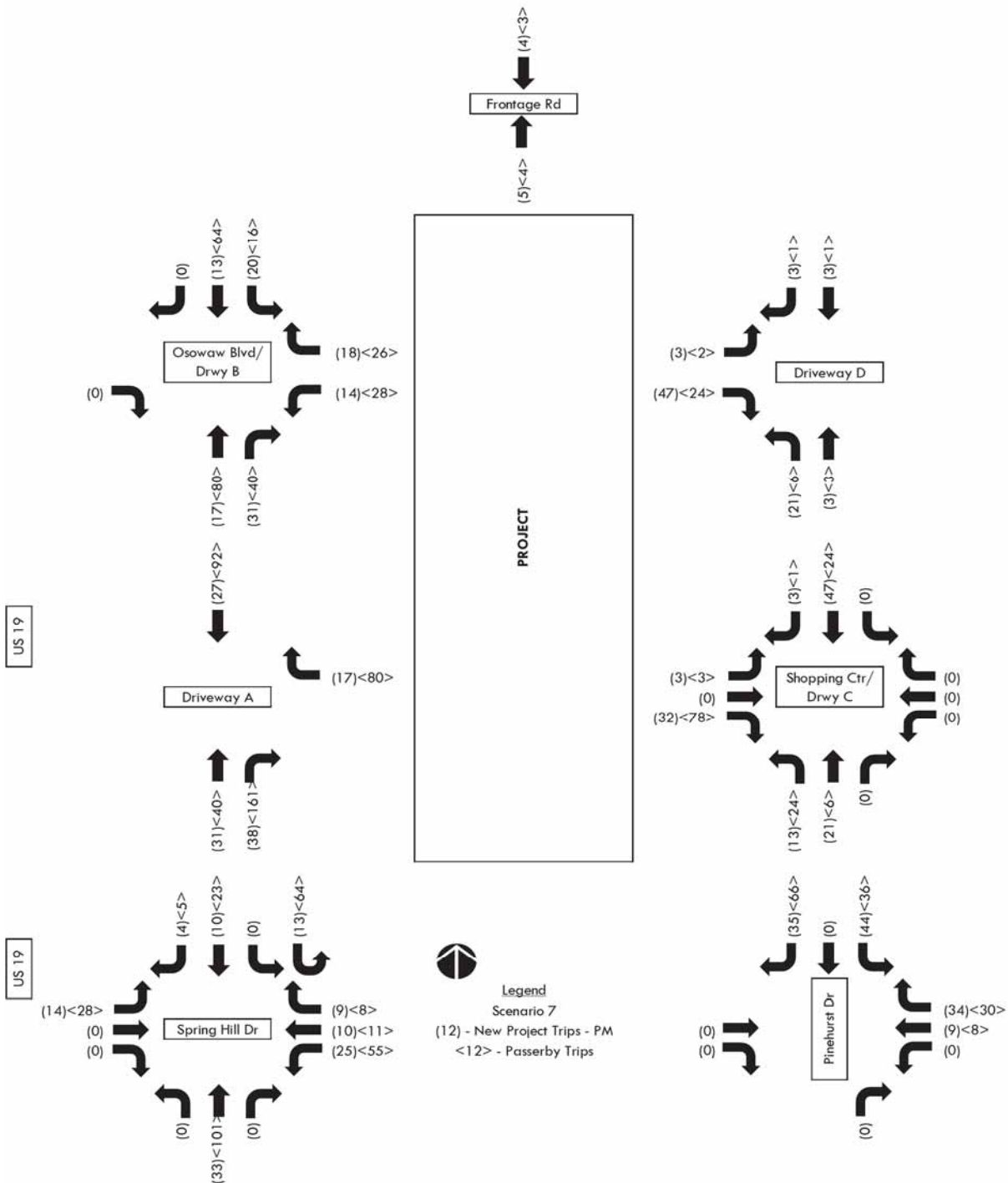

Figure 16. Scenario 8 – Project Traffic – AM Peak Hour

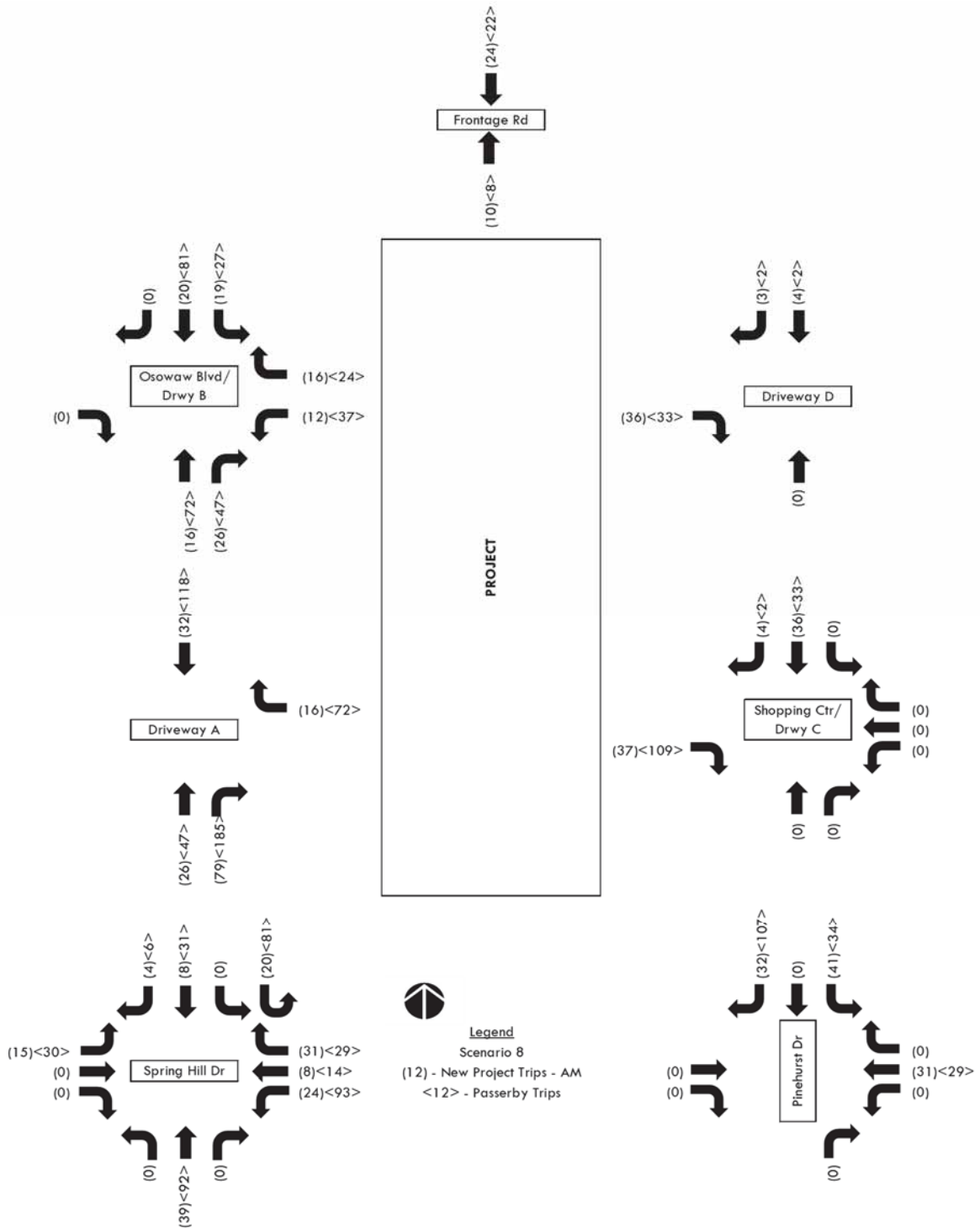
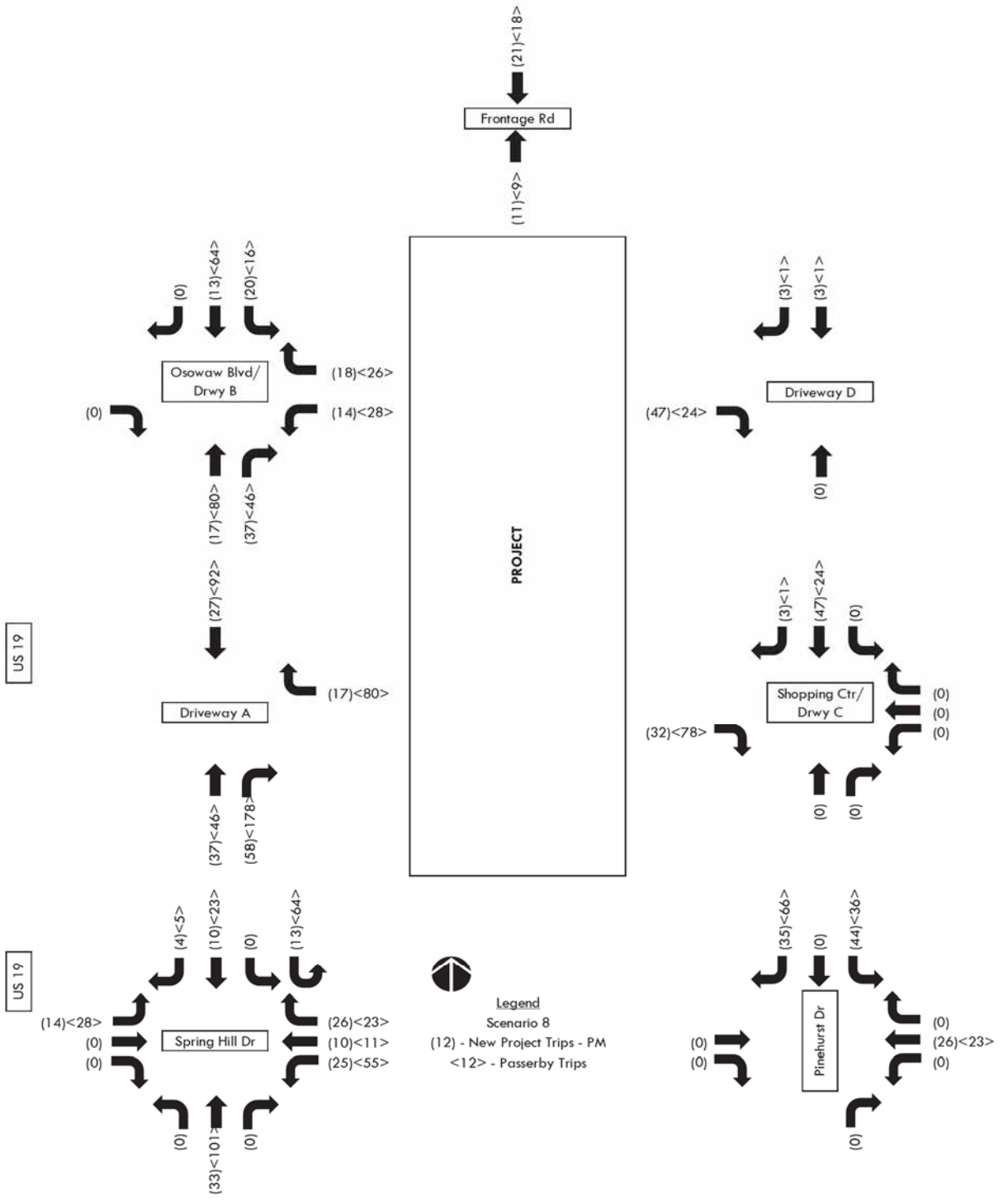

Figure 17. Scenario 8 – Project Traffic – PM Peak Hour



STUDY AREA

The study area for this analysis was determined to include all major road network facilities in which the peak hour project traffic consumes 4.5 percent or more of the adopted level of service capacity of the roadway. Table 5 shows the Study Area Determination for the project. As shown in the table, the project traffic does not consume more than 4.5 percent of the peak hour capacity on any of the adjacent links except for Pinehurst Drive. Therefore, only the adjacent links will be included in the study area:

ADJACENT ROADWAYS

As stated previously, the site is located east of US 19 and north of Spring Hill Drive. US 19 is a six-lane divided roadway. Spring Hill Drive is a four (4) lane divided roadway. According to the FDOT Work Program and Hernando County Capital Improvement Plan, there are no other programmed capacity improvements in the vicinity of the project.

BUILDOUT

It is anticipated the project will have a 2023 buildout date.

Table 5. Study Area Determination

<u>Roadway</u>	<u>From</u>	<u>To</u>	<u>Lanes</u>	<u>Peak Hour Two-Way Capacity (1)</u>	<u>PM Peak Hour Project Traffic</u>	<u>Percent Consumed</u>
US 19	Applegate Dr	Spring Hill Dr	6LD	5,390	68	1.3%
	Spring Hill Dr	Trenton Ave	6LD	5,390	90	1.7%
Spring Hill Dr	US 19	Pinehurst Dr	4LD	3,222	37	1.1%
	Pinehurst Dr	Kenlake Ave	4LD	3,222	96	3.0%
Pinehurst Dr	Spring Hill Dr	Project	2LU	1,197	115	9.6%

(1) Source: FDOT Generalized Level of Service Tables.

Local 4LD: $3,580 \times 0.90 = 3,222$

Local 2LU: $1,330 \times 0.90 = 1,197$

BACKGROUND TRAFFIC

The following methodology was utilized to estimate the existing volumes within the study area:

1. PALM TRAFFIC conducted AM (7:00 – 9:00) and PM (4:00 – 6:00) peak hour turning movement counts at the following intersections:
 - US 19 and Spring Hill Drive/Osowaw Boulevard
 - US 19 and Osowaw Boulevard
 - Spring Hill Drive and Pinehurst Drive
 - Pinehurst Drive and Spring Hill Commons Driveway.

Figure 18 illustrates the existing traffic for the AM and PM peak hours.

2. The turning movement counts were adjusted to the peak season based on the FDOT Peak Season Adjustment Factors for Hernando County of 1.08. Figure 19 illustrates the peak season traffic for the AM and PM peak hours.
3. Based on FDOT historical traffic counts on US 19 in the area, there has been approximately a 1.23 percent annual growth rate over the past 10 years. Therefore, an annual growth rate of 1.5 percent per year was used to determine the background traffic in the buildout year of 2023. Figure 20 illustrates the background traffic. Figure 21 and Figure 22 illustrate the AM and PM background plus project traffic for Access Scenario 1, respectively. Figure 23 and Figure 24 illustrate the AM and PM background plus project traffic for Access Scenario 2, respectively. Figure 25 and Figure 26 illustrate the AM and PM background plus project traffic for Access Scenario 3, respectively. Figure 27 and Figure 28 illustrate the AM and PM background plus project traffic for Access Scenario 4, respectively. Figure 27 and Figure 28 illustrate the AM and PM background plus project traffic for Access Scenario 4, respectively. Figure 27 and Figure 28 illustrate the AM and PM background plus project traffic for Access Scenario 4, respectively.

Figure 18. Existing Traffic

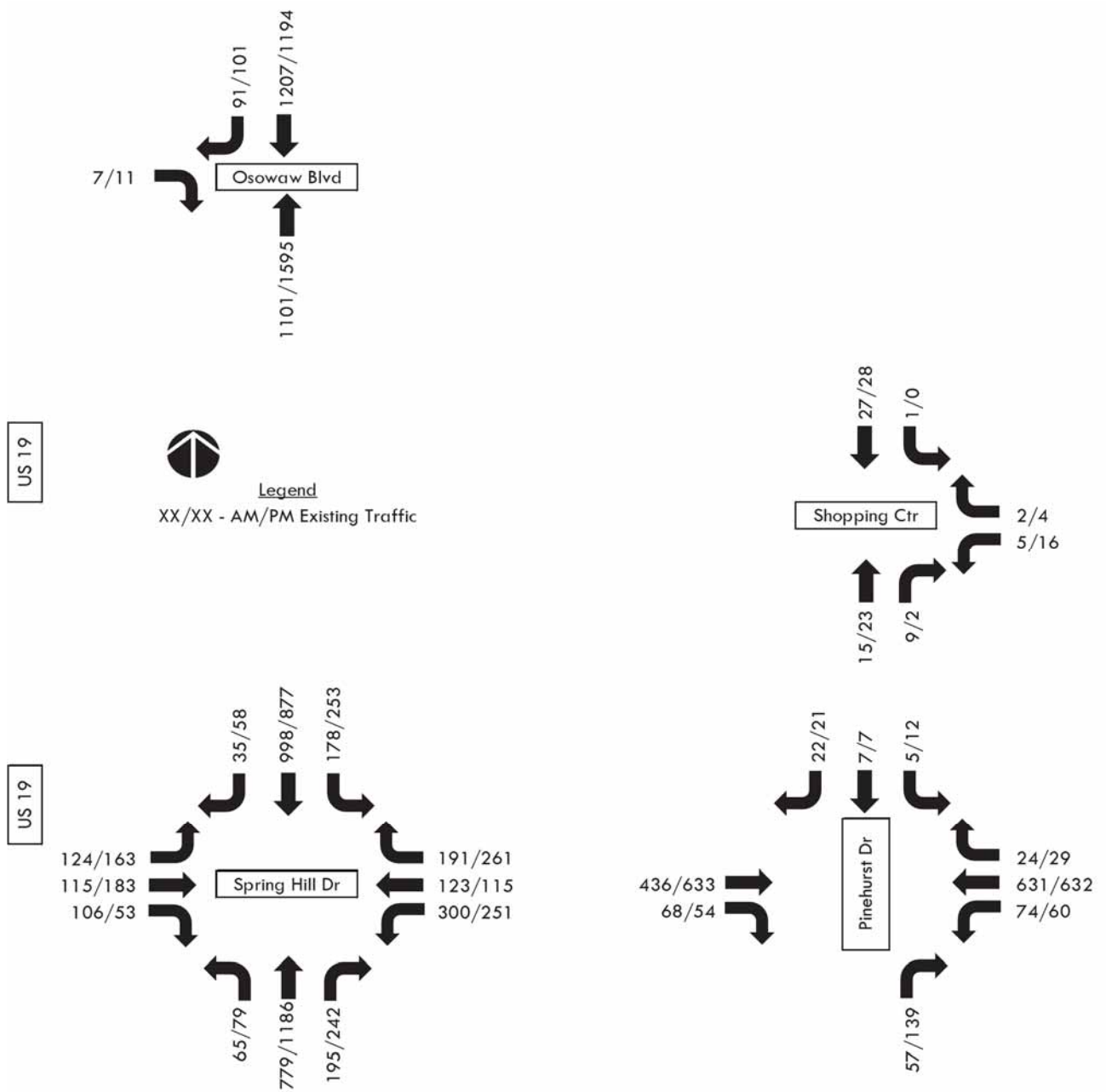

Figure 19. Peak Season Traffic

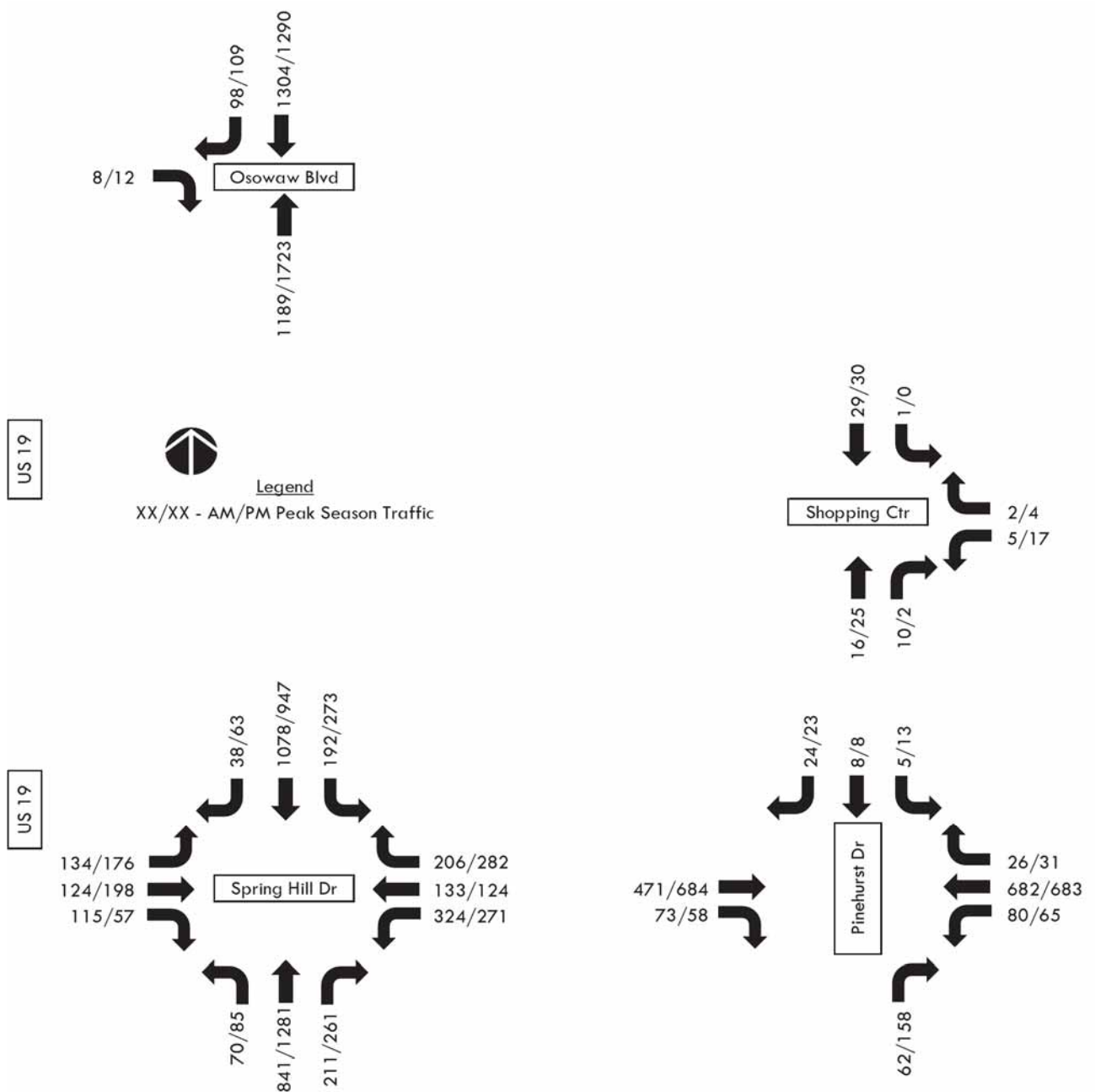

Figure 20. Background Traffic

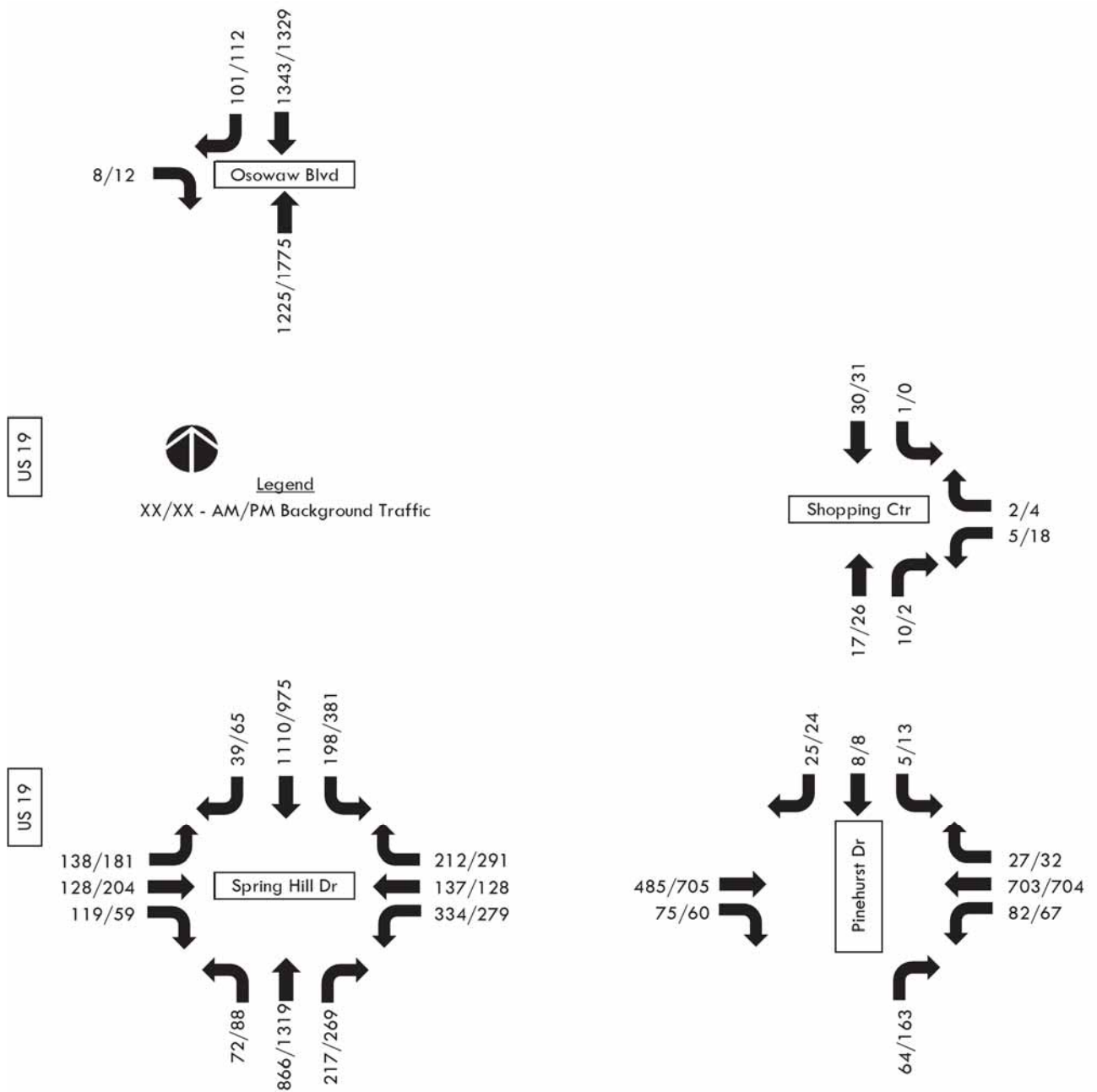

Figure 21. Scenario 1 – Background Plus Project Traffic – AM Peak Hour

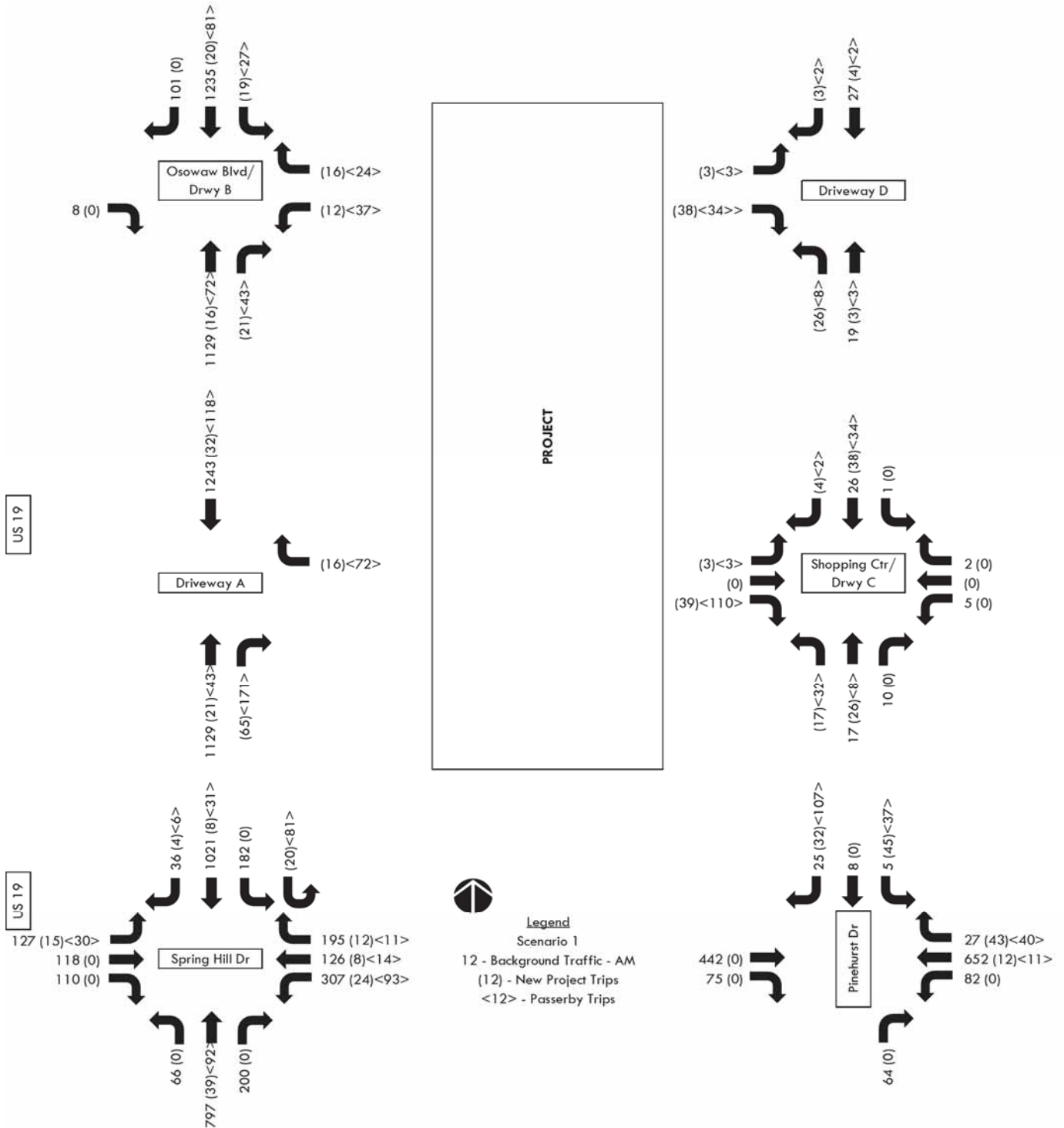

Figure 22. Scenario 1 – Background Plus Project Traffic – PM Peak Hour

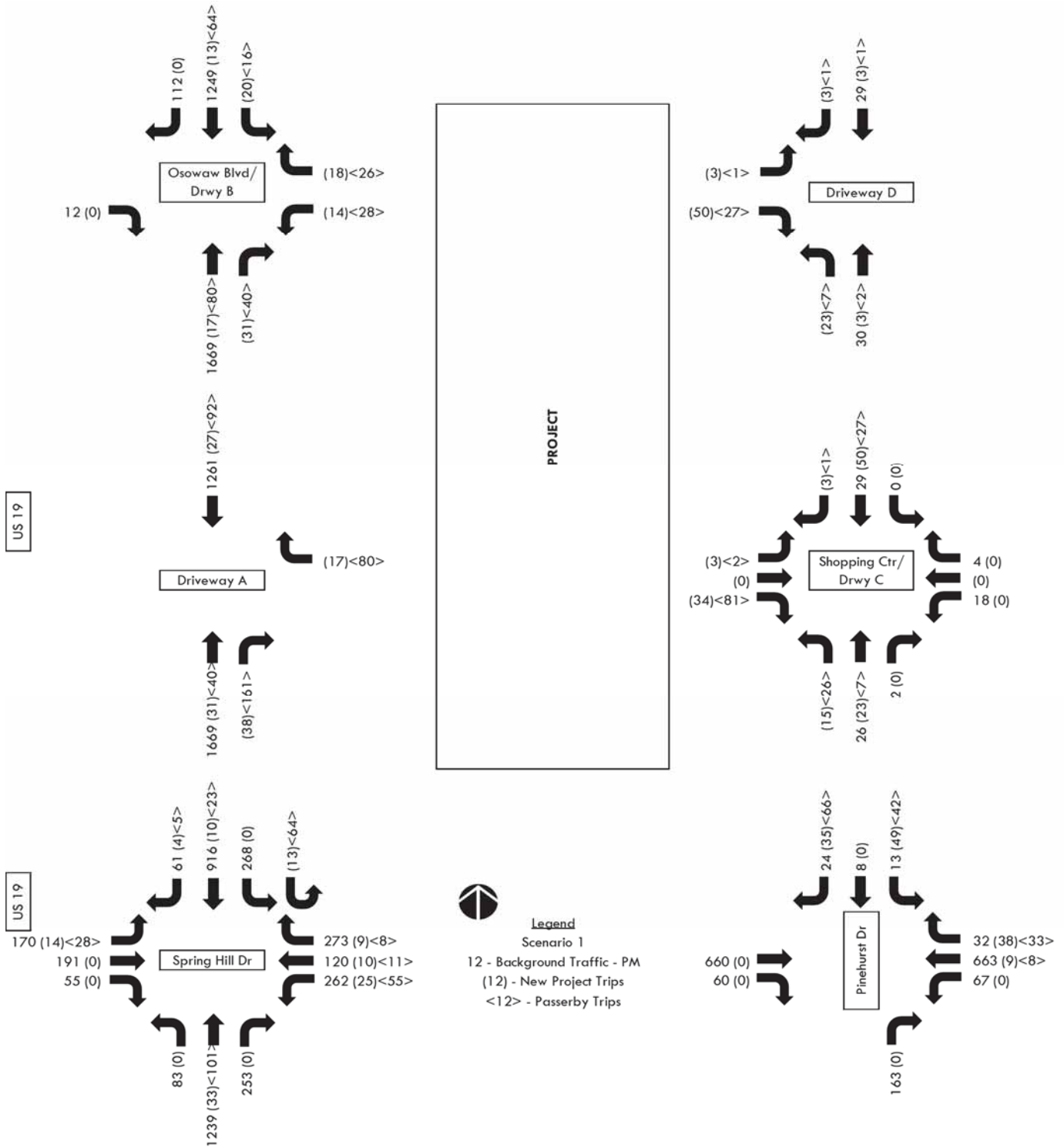

Figure 23. Scenario 2 – Background Plus Project Traffic – AM Peak Hour

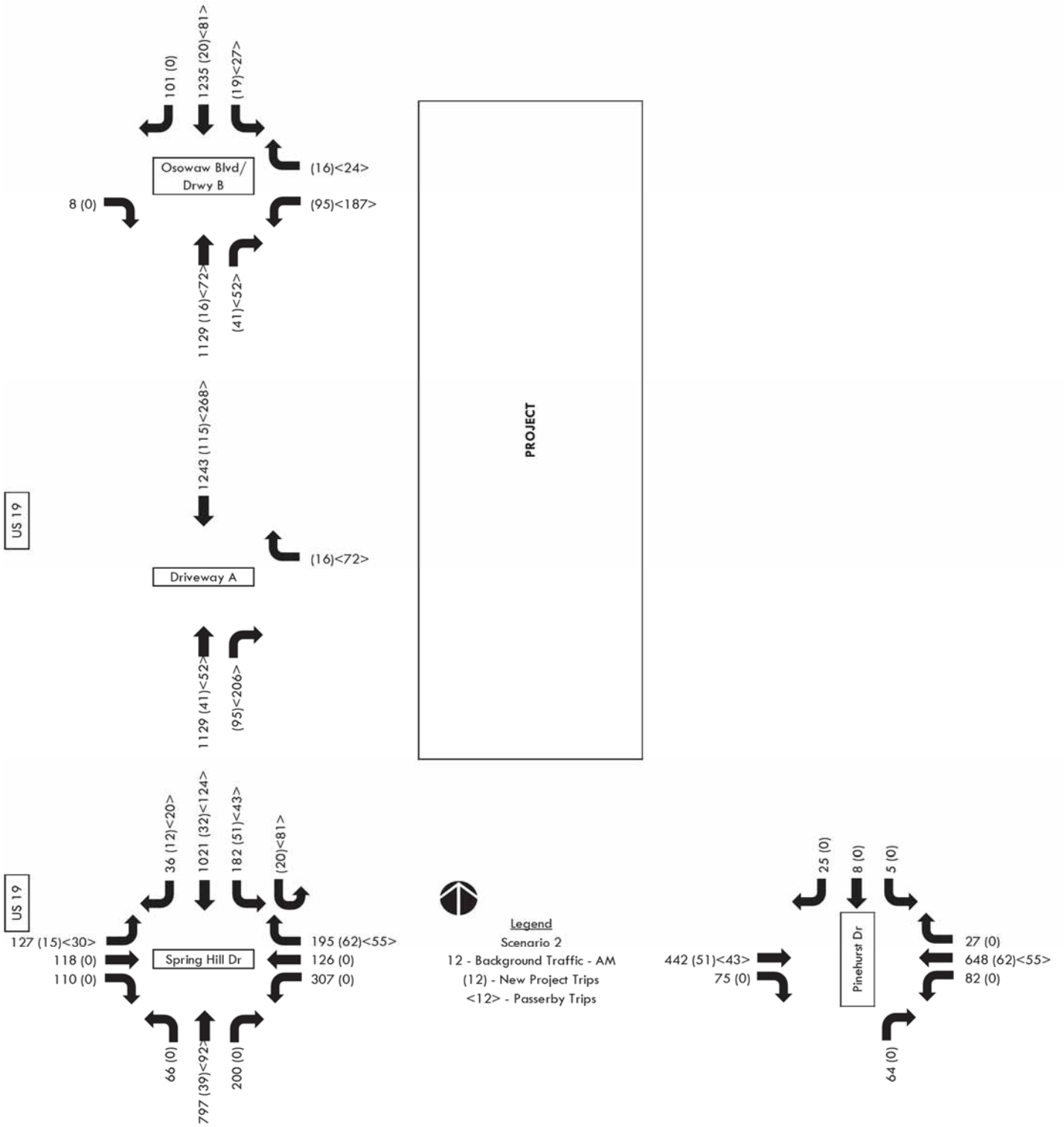

Figure 24. Scenario 2 – Background Plus Project Traffic – PM Peak Hour

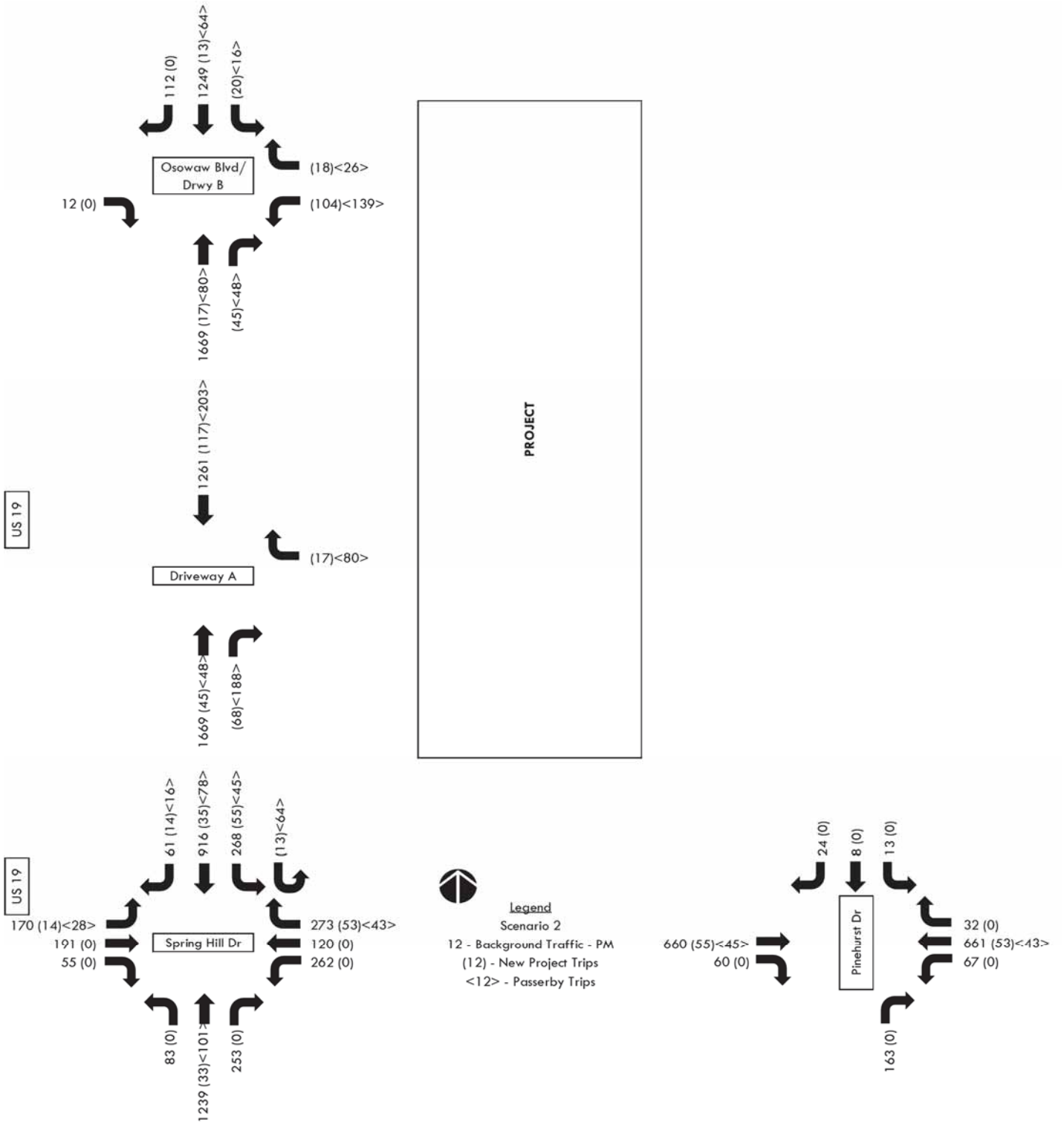

Figure 25. Scenario 3 – Background Plus Project Traffic – AM Peak Hour

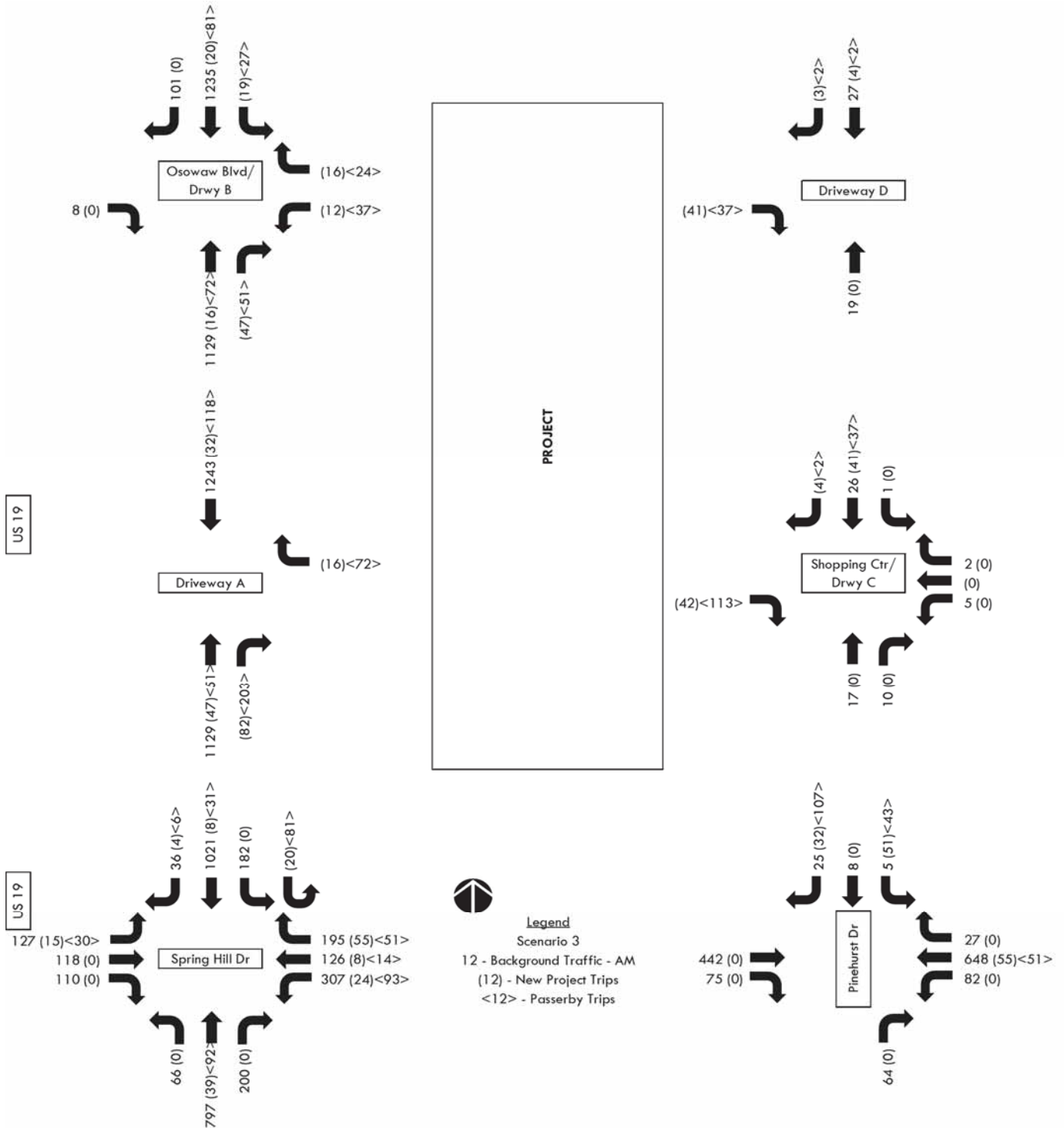

Figure 26. Scenario 3 – Background Plus Project Traffic – PM Peak Hour

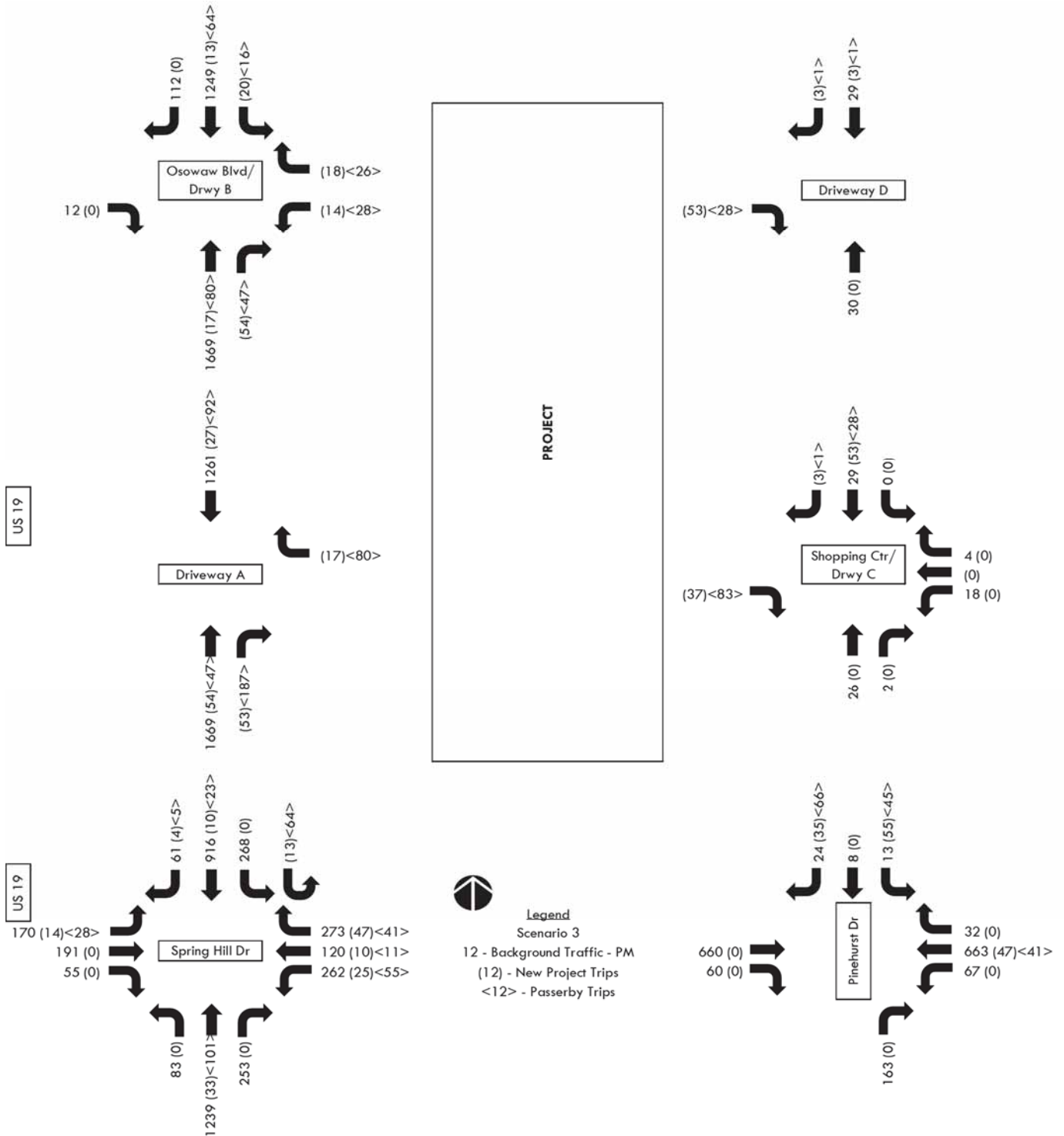

Figure 27. Scenario 4 – Background Plus Project Traffic – AM Peak Hour

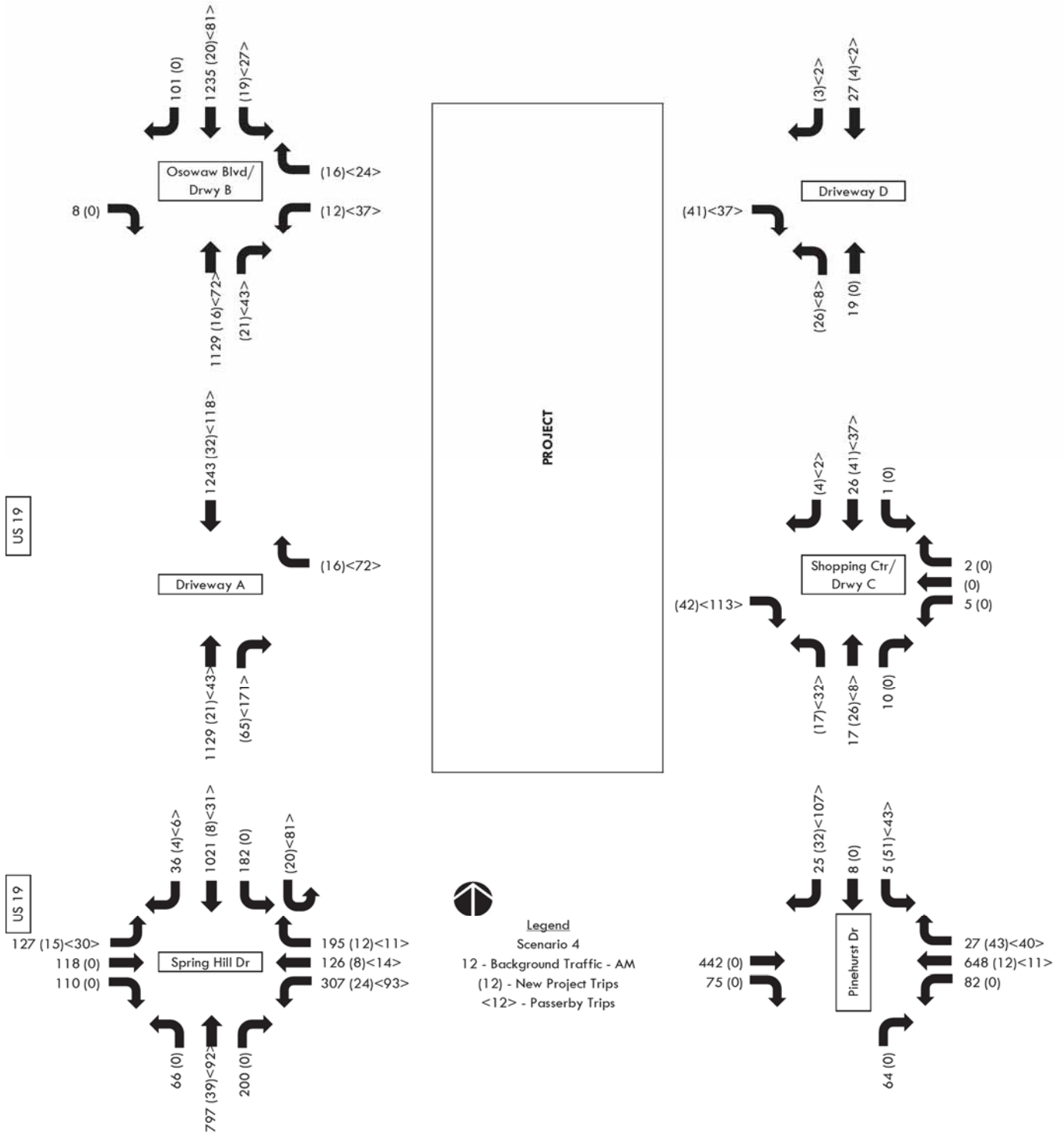

Figure 28. Scenario 4 – Background Plus Project Traffic – PM Peak Hour

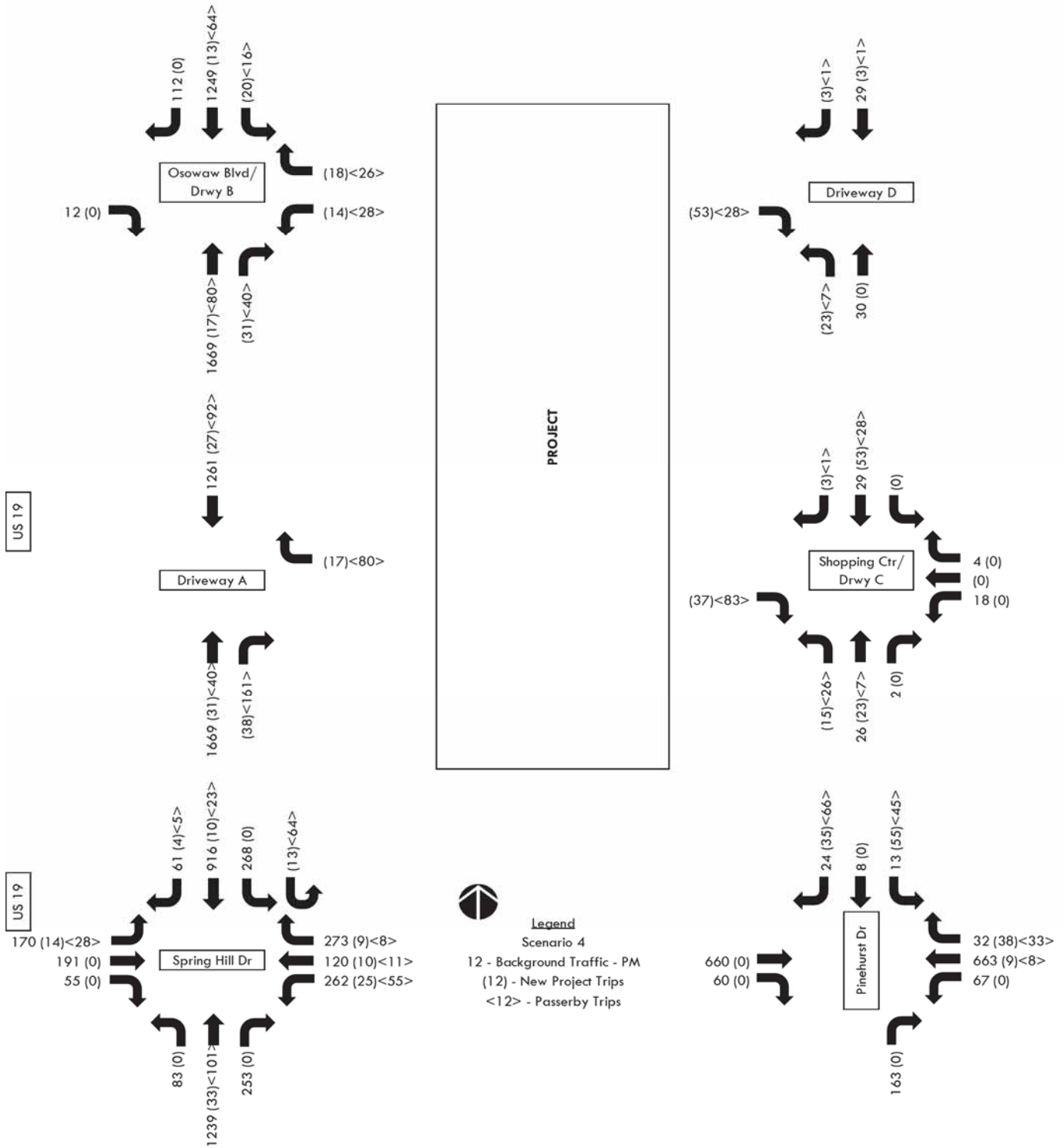

Figure 29. Scenario 5 – Background Plus Project Traffic – AM Peak Hour

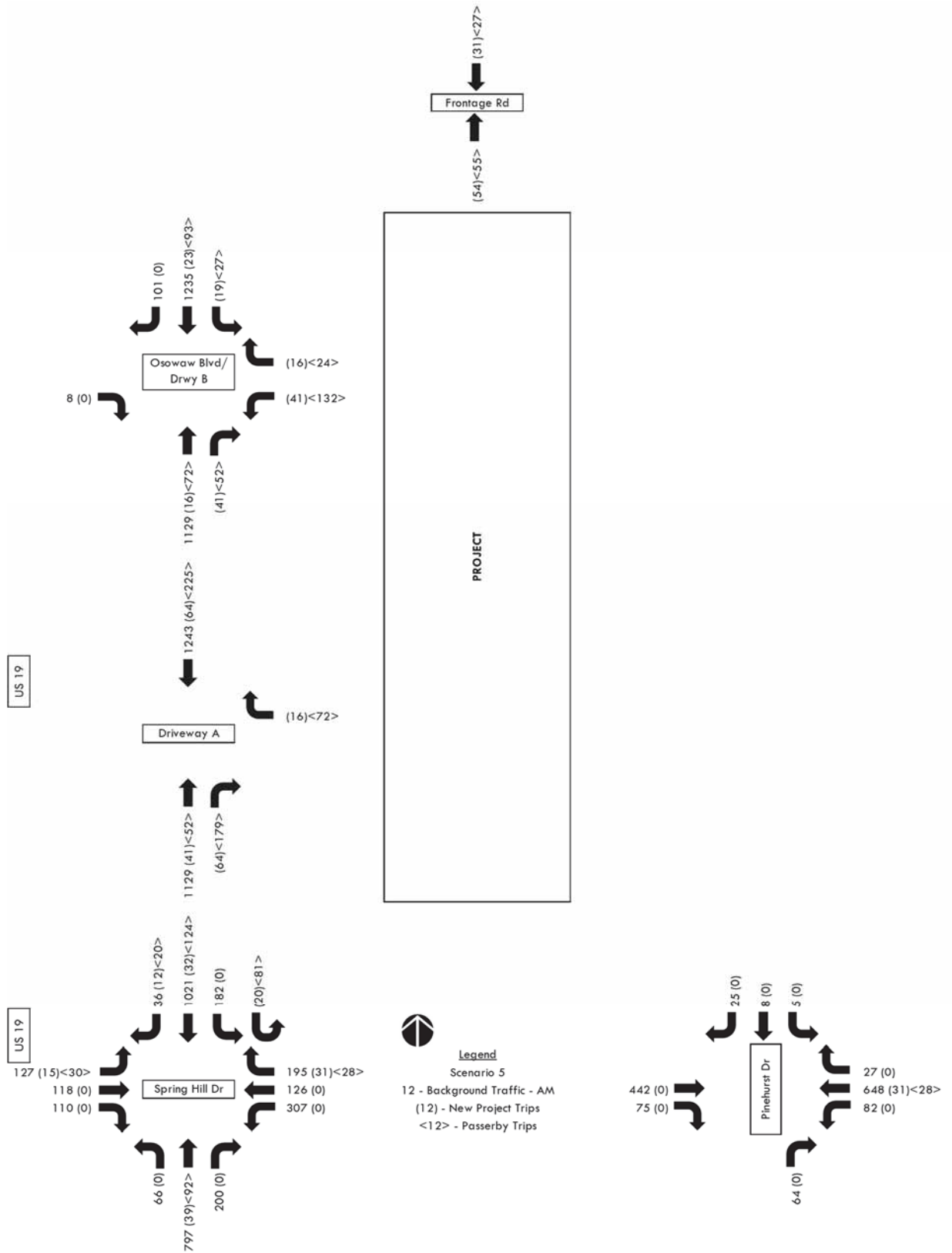

Figure 30. Scenario 5 – Background Plus Project Traffic – PM Peak Hour

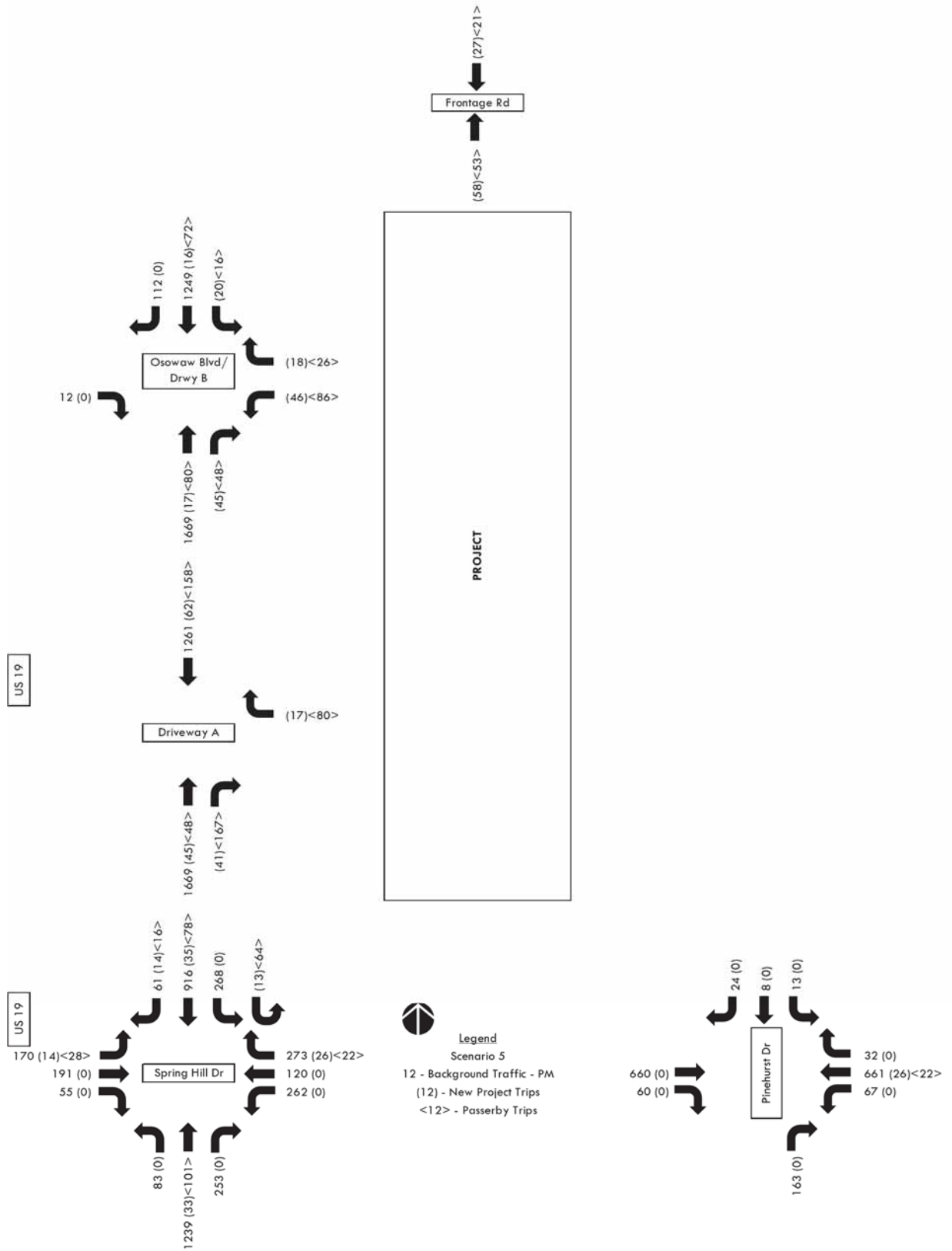

Figure 31. Scenario 6 – Background Plus Project Traffic – AM Peak Hour

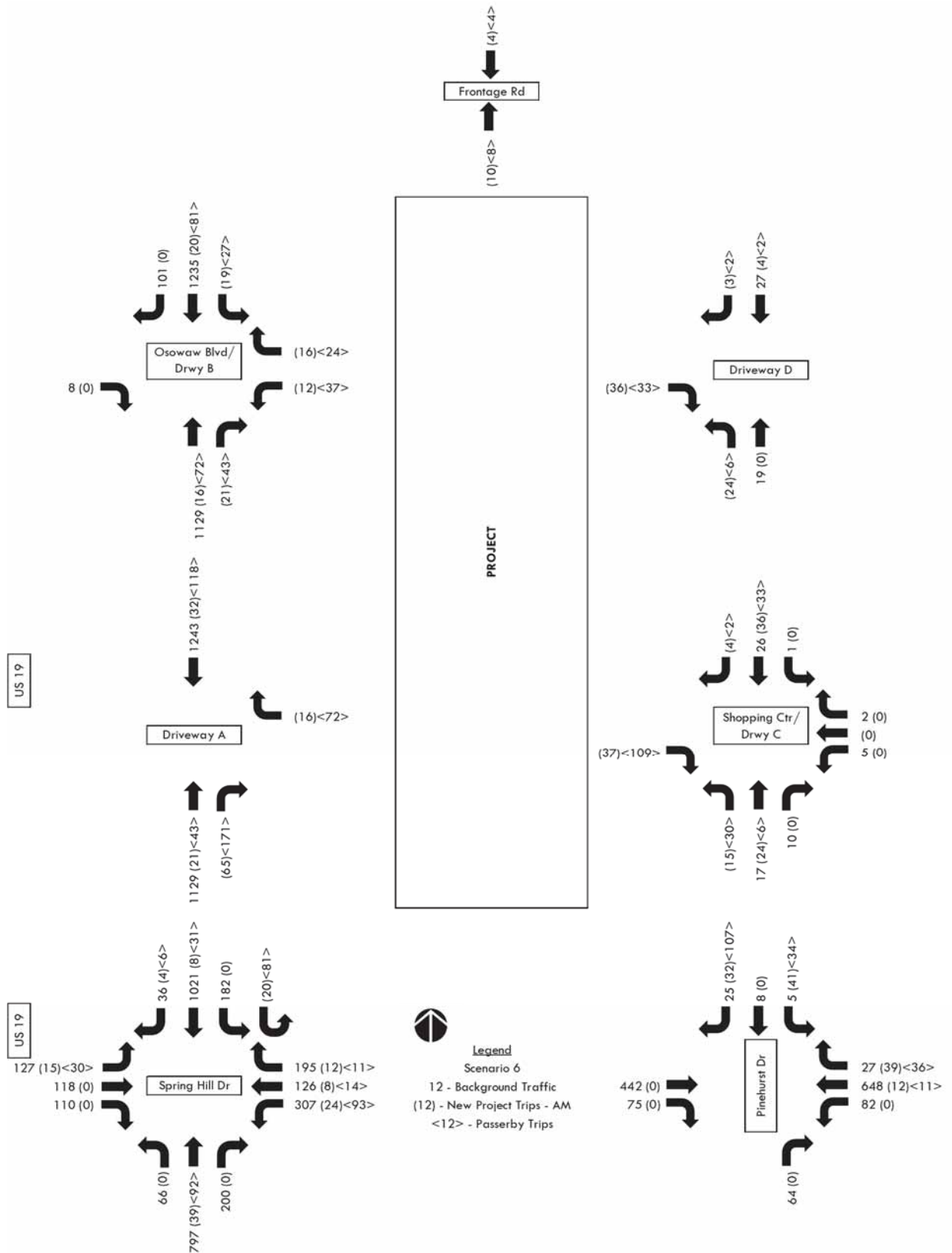

Figure 32. Scenario 6 – Background Plus Project Traffic – PM Peak Hour

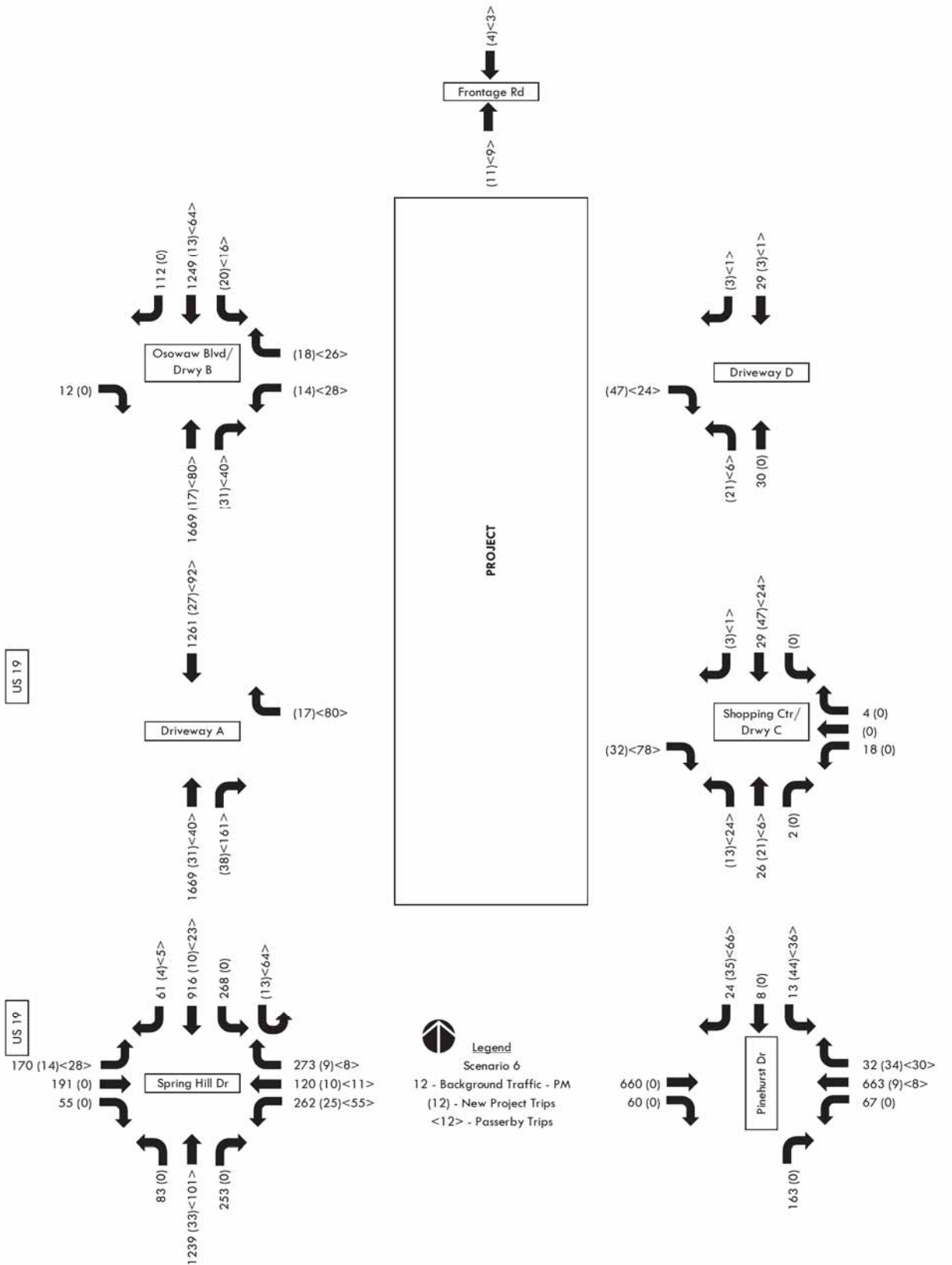

Figure 33. Scenario 7 – Background Plus Project Traffic – AM Peak Hour

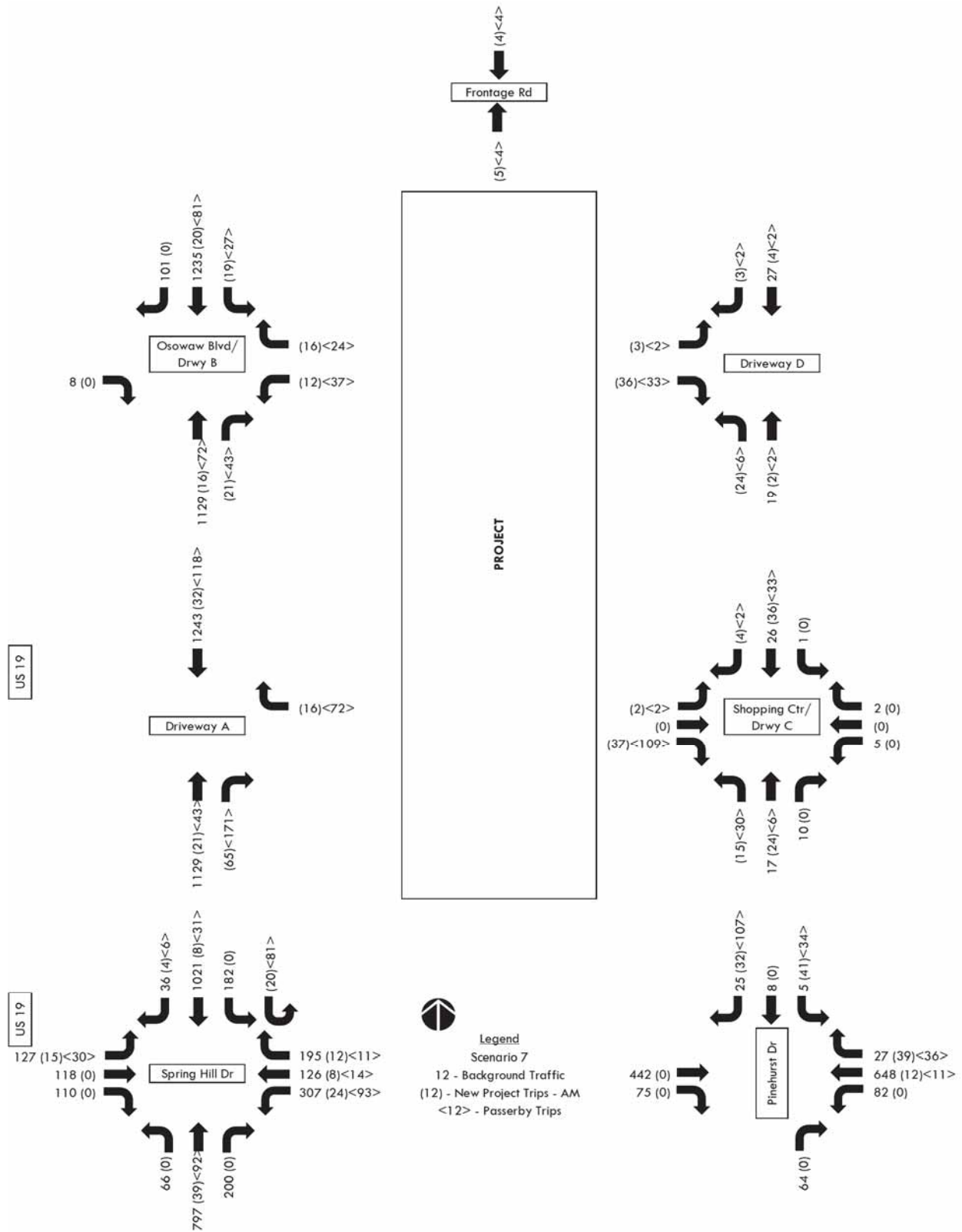

Figure 34. Scenario 7 – Background Plus Project Traffic – PM Peak Hour

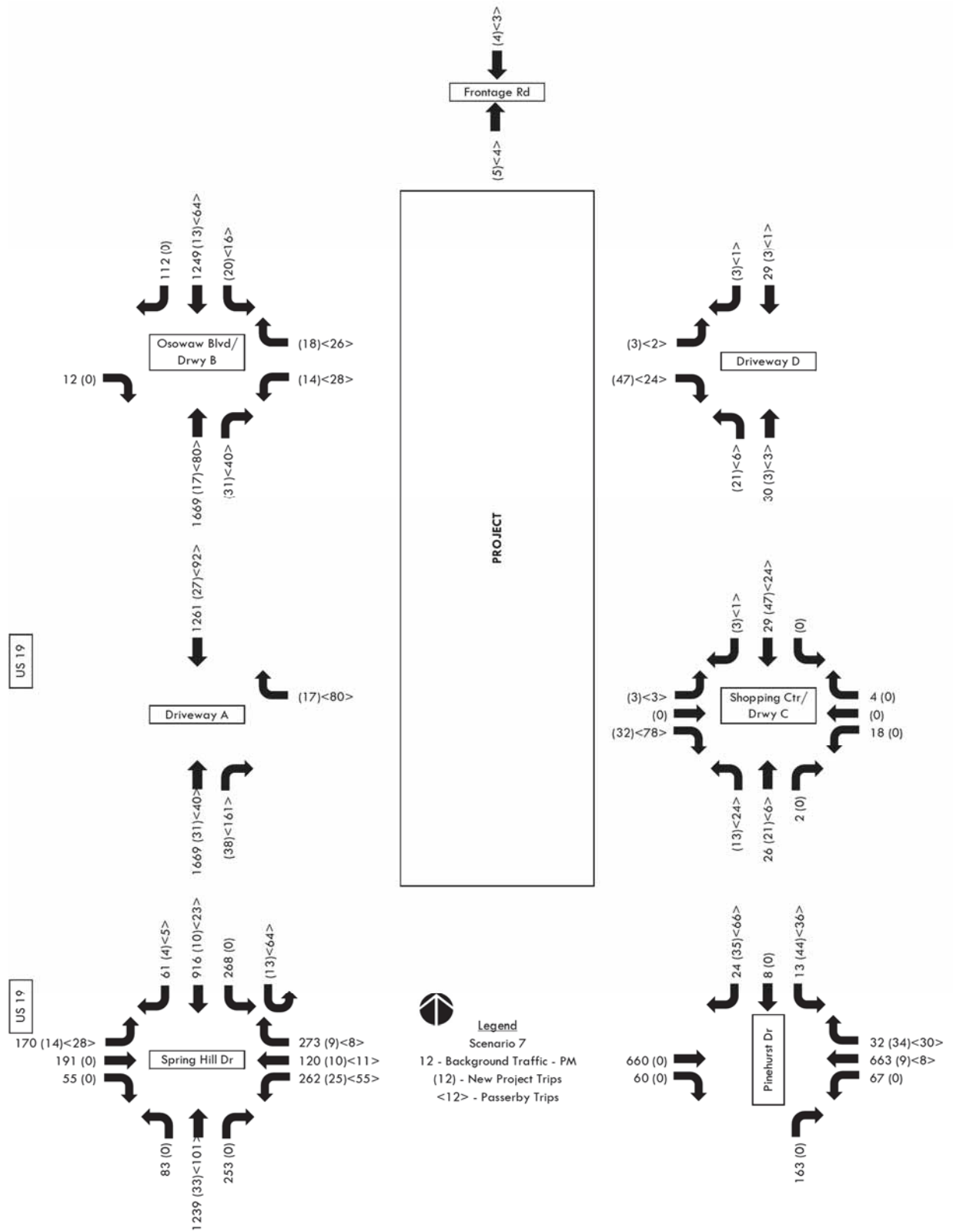

Figure 35. Scenario 8 – Background Plus Project Traffic – AM Peak Hour

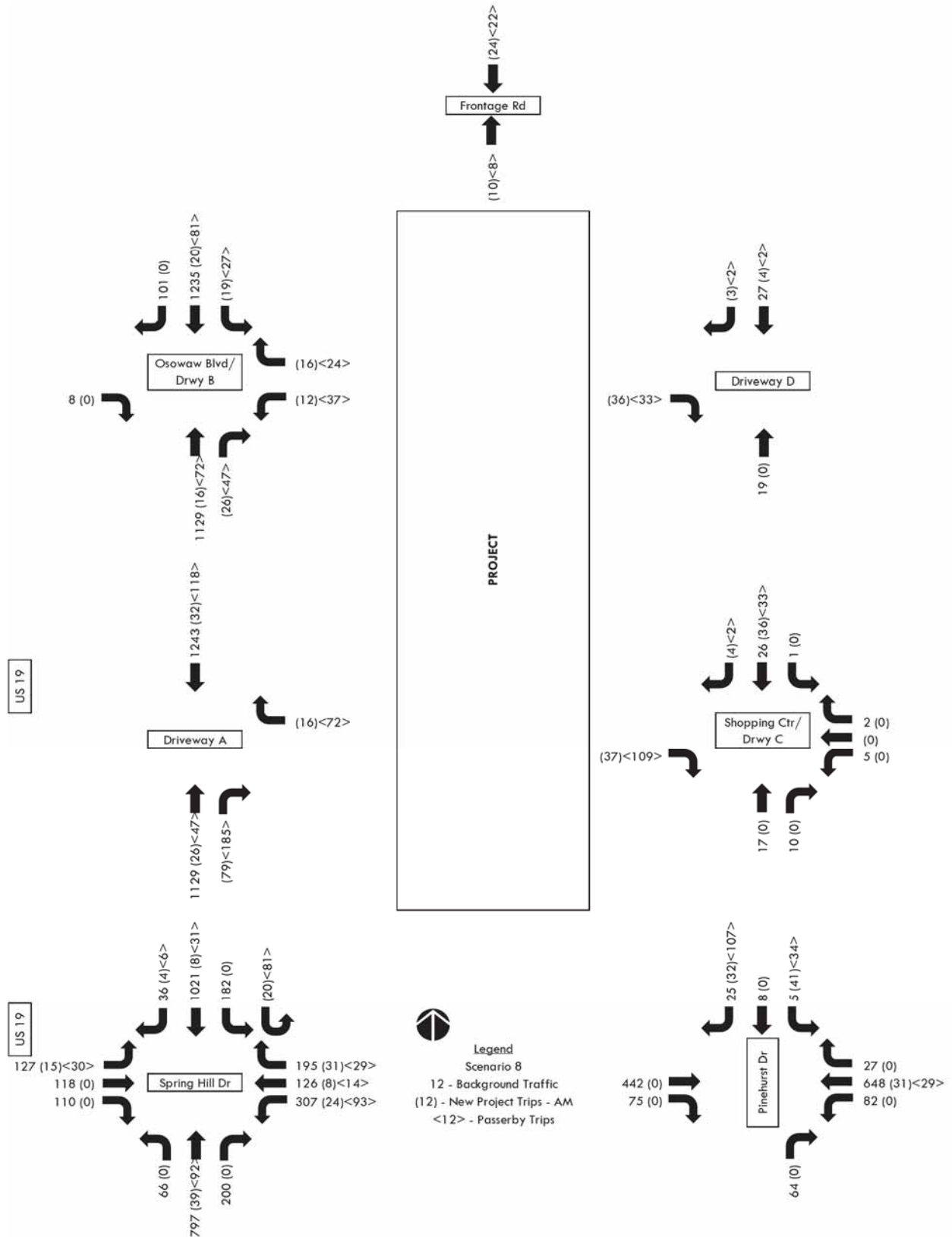
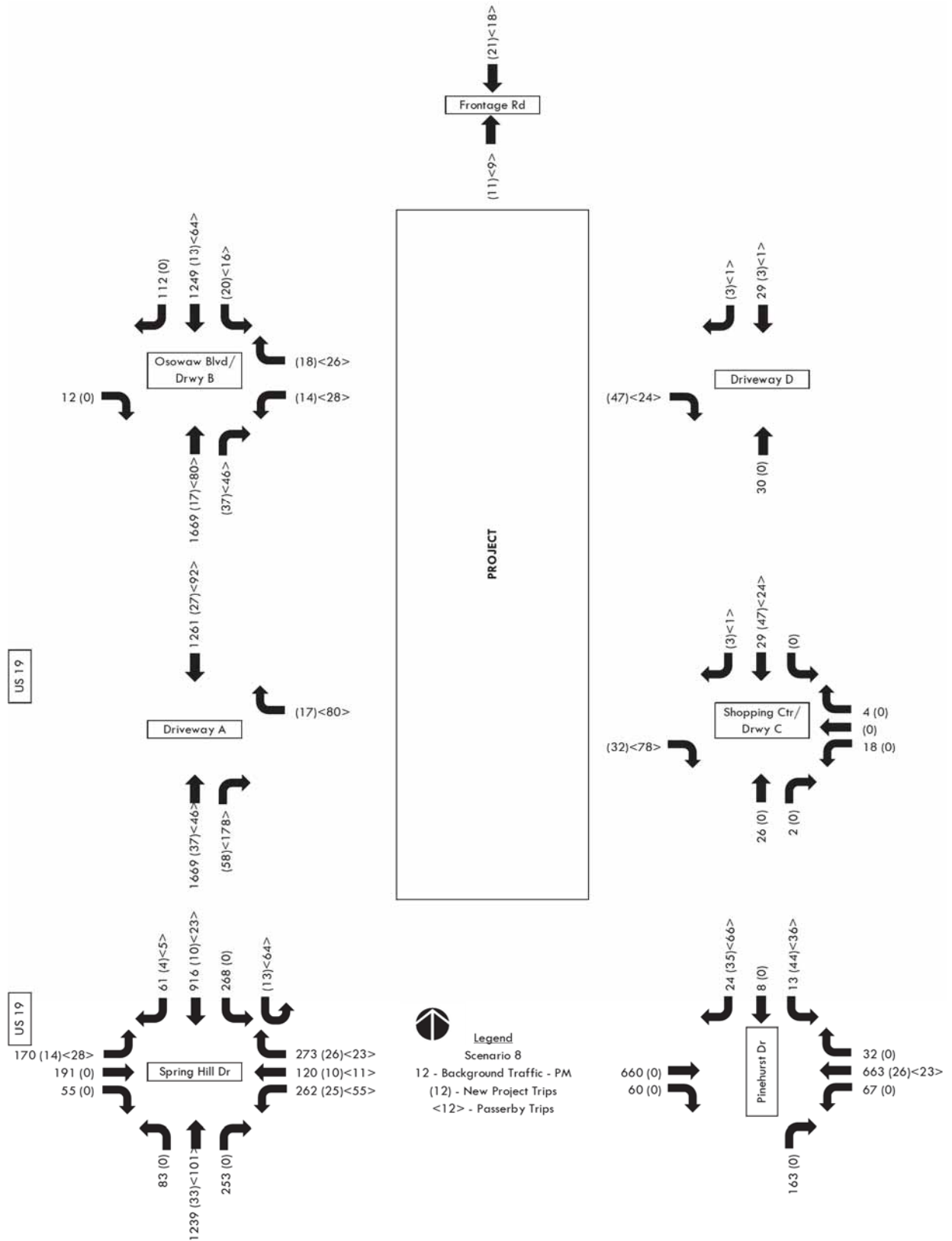

Figure 36. Scenario 8 – Background Plus Project Traffic – PM Peak Hour



INTERSECTION ANALYSIS

Intersection analysis was conducted for the AM and PM peak hours at the following intersections:

- US 19 and Spring Hill Drive
- US 19 and Osowaw Boulevard/Driveway B
- Spring Hill Drive and Pinehurst Drive.

The analysis was based on SYNCHRO with the proposed project traffic. Table 6, Table 7, Table 8, Table 9, Table 10, Table 11, Table 12 and Table 13 summarize the signalized intersection analysis results for Scenarios 1, 2, 3, 4, 5, 6, 7 and 8 respectively. The results are also described in the following paragraphs:

US 19 and Spring Hill Drive

Signalized intersection analysis indicates that all the individual movements should operate with a volume to capacity (v/c) ratio less than 1.0 during the AM and PM peak hours with background plus project traffic for all six scenarios.

US 19 and Osowaw Boulevard/Driveway B

The intersection is unsignalized. Unsignalized intersection analysis indicates that all movements should operate with a v/c ratio less than 1.0 during the background plus project traffic during the AM and PM peak hours for Scenario 1, 3, 4, 6, 7 and 8. The intersection has one or two movements with v/c ratios greater than 1.0 for Scenarios 2 and 5.

Spring Hill Drive and Pinehurst Drive

The intersection is unsignalized. Unsignalized intersection analysis indicates that all the individual movements should operate with a v/c ratio less than 1.0 during the AM and PM peak hours with background plus project traffic for all six scenarios.

Table 6. Estimated Intersection Volume to Capacity – Scenario 1

<u>Intersection</u>	<u>Movement</u>	<u>AM Peak Hour Background Plus Project Traffic</u>			<u>PM Peak Hour Background Plus Project Traffic</u>		
		<u>Left</u>	<u>Through</u>	<u>Right</u>	<u>Left</u>	<u>Through</u>	<u>Right</u>
US 19 and Spring Hill Drive	EB	0.58	0.42	0.34	0.64	0.58	0.19
	WB	0.86	0.58	0.54	0.79	0.61	0.83
	NB	0.54	0.47	0.27	0.64	0.70	0.33
	SB	0.70	0.46	0.06	0.80	0.43	0.09
US 19 and Osowaw Boulevard/Driveway B	EB	-	-	0.03	-	-	0.04
	WB	0.44	-	0.12	0.96	-	0.20
	NB	-	*	*	-	*	*
	SB	0.18	*	*	0.28	*	*
Spring Hill Drive and Pinehurst Drive	EB	-	*	*	-	*	*
	WB	0.09	*	*	0.08	*	*
	NB	-	-	0.09	-	-	0.28
	SB	0.68	*	*	0.72	0.72	0.72

* Free flow movement

Table 7. Estimated Intersection Volume to Capacity – Scenario 2

<u>Intersection</u>	<u>Movement</u>	<u>AM Peak Hour Background Plus Project Traffic</u>			<u>PM Peak Hour Background Plus Project Traffic</u>		
		<u>Left</u>	<u>Through</u>	<u>Right</u>	<u>Left</u>	<u>Through</u>	<u>Right</u>
US 19 and Spring Hill Drive	EB	0.58	0.40	0.33	0.64	0.39	0.15
	WB	0.73	0.56	0.80	0.69	0.41	0.94
	NB	0.54	0.47	0.27	0.65	0.78	0.36
	SB	0.80	0.49	0.08	0.96	0.50	0.12
US 19 and Osowaw Boulevard/Driveway B	EB	-	-	0.03	-	-	0.04
	WB	2.54	-	0.12	5.56	-	0.20
	NB	-	*	*	-	*	*
	SB	0.19	*	*	0.29	*	*
Spring Hill Drive and Pinehurst Drive	EB	-	*	*	-	*	*
	WB	0.09	*	*	0.09	*	*
	NB	-	-	0.10	-	-	0.30
	SB	0.10	0.10	0.10	0.15	0.15	0.15

* Free flow movement

Table 8. Estimated Intersection Volume to Capacity – Scenario 3

<u>Intersection</u>	<u>Movement</u>	<u>AM Peak Hour Background Plus Project Traffic</u>			<u>PM Peak Hour Background Plus Project Traffic</u>		
		<u>Left</u>	<u>Through</u>	<u>Right</u>	<u>Left</u>	<u>Through</u>	<u>Right</u>
US 19 and Spring Hill Drive	EB	0.58	0.41	0.34	0.64	0.45	0.17
	WB	0.86	0.58	0.73	0.79	0.50	0.94
	NB	0.54	0.47	0.27	0.65	0.75	0.35
	SB	0.70	0.46	0.06	0.80	0.45	0.10
US 19 and Osowaw Boulevard/Driveway B	EB	-	-	0.03	-	-	0.04
	WB	0.44	-	0.12	0.96	-	0.20
	NB	-	*	*	-	*	*
	SB	0.19	*	*	0.29	*	*
Spring Hill Drive and Pinehurst Drive	EB	-	*	*	-	*	*
	WB	0.09	*	*	0.08	*	*
	NB	-	-	0.09	-	-	0.28
	SB	0.75	0.75	0.75	0.78	0.78	0.78

* Free flow movement

Table 9. Estimated Intersection Volume to Capacity – Scenario 4

<u>Intersection</u>	<u>Movement</u>	<u>AM Peak Hour Background Plus Project Traffic</u>			<u>PM Peak Hour Background Plus Project Traffic</u>		
		<u>Left</u>	<u>Through</u>	<u>Right</u>	<u>Left</u>	<u>Through</u>	<u>Right</u>
US 19 and Spring Hill Drive	EB	0.59	0.42	0.34	0.64	0.58	0.19
	WB	0.86	0.61	0.55	0.79	0.61	0.83
	NB	0.55	0.48	0.27	0.64	0.70	0.33
	SB	0.71	0.46	0.06	0.80	0.43	0.09
US 19 and Osowaw Boulevard/Driveway B	EB	-	-	0.03	-	-	0.04
	WB	0.56	-	0.13	0.96	-	0.20
	NB	-	*	*	-	*	*
	SB	0.22	*	*	0.28	*	*
Spring Hill Drive and Pinehurst Drive	EB	-	*	*	-	*	*
	WB	0.09	*	*	0.08	*	*
	NB	-	-	0.09	-	-	0.28
	SB	0.80	0.80	0.80	0.76	0.76	0.76

* Free flow movement

Table 10. Estimated Intersection Volume to Capacity – Scenario 5

<u>Intersection</u>	<u>Movement</u>	<u>AM Peak Hour Background Plus Project Traffic</u>			<u>PM Peak Hour Background Plus Project Traffic</u>		
		<u>Left</u>	<u>Through</u>	<u>Right</u>	<u>Left</u>	<u>Through</u>	<u>Right</u>
US 19 and Spring Hill Drive	EB	0.58	0.43	0.34	0.64	0.48	0.17
	WB	0.73	0.59	0.67	0.69	0.51	0.91
	NB	0.53	0.44	0.26	0.65	0.71	0.33
	SB	0.70	0.48	0.08	0.80	0.47	0.12
US 19 and Osowaw Boulevard/Driveway B	EB	-	-	0.03	-	-	0.04
	WB	1.57	-	0.12	3.02	-	0.20
	NB	-	*	*	-	*	*
	SB	0.19	*	*	0.29	*	*
Spring Hill Drive and Pinehurst Drive	EB	-	*	*	-	*	*
	WB	0.09	*	*	0.08	*	*
	NB	-	-	0.09	-	-	0.28
	SB	0.10	0.10	0.10	0.13	0.13	0.13

* Free flow movement

Table 11. Estimated Intersection Volume to Capacity – Scenario 6

<u>Intersection</u>	<u>Movement</u>	<u>AM Peak Hour Background Plus Project Traffic</u>			<u>PM Peak Hour Background Plus Project Traffic</u>		
		<u>Left</u>	<u>Through</u>	<u>Right</u>	<u>Left</u>	<u>Through</u>	<u>Right</u>
US 19 and Spring Hill Drive	EB	0.58	0.42	0.34	0.64	0.58	0.19
	WB	0.86	0.58	0.54	0.79	0.61	0.83
	NB	0.54	0.45	0.26	0.64	0.70	0.33
	SB	0.64	0.46	0.06	0.80	0.43	0.09
US 19 and Osowaw Boulevard/Driveway B	EB	-	-	0.03	-	-	0.04
	WB	0.44	-	0.12	0.96	-	0.20
	NB	-	*	*	-	*	*
	SB	0.18	*	*	0.28	*	*
Spring Hill Drive and Pinehurst Drive	EB	-	*	*	-	*	*
	WB	0.09	*	*	0.08	*	*
	NB	-	-	0.09	-	-	0.28
	SB	0.65	0.65	0.65	0.67	0.67	0.67

* Free flow movement

Table 12. Estimated Intersection Volume to Capacity – Scenario 7

<u>Intersection</u>	<u>Movement</u>	<u>AM Peak Hour Background Plus Project Traffic</u>			<u>PM Peak Hour Background Plus Project Traffic</u>		
		<u>Left</u>	<u>Through</u>	<u>Right</u>	<u>Left</u>	<u>Through</u>	<u>Right</u>
US 19 and Spring Hill Drive	EB	0.58	0.42	0.34	0.64	0.58	0.19
	WB	0.86	0.58	0.54	0.79	0.61	0.83
	NB	0.54	0.47	0.27	0.64	0.70	0.33
	SB	0.70	0.46	0.06	0.80	0.43	0.09
US 19 and Osowaw Boulevard/Driveway B	EB	-	-	0.03	-	-	0.04
	WB	0.44	-	0.12	0.96	-	0.20
	NB	-	*	*	-	*	*
	SB	0.18	*	*	0.28	*	*
Spring Hill Drive and Pinehurst Drive	EB	-	*	*	-	*	*
	WB	0.09	*	*	0.08	*	*
	NB	-	-	0.09	-	-	0.28
	SB	0.65	0.65	0.65	0.67	0.67	0.67

* Free flow movement

Table 13. Estimated Intersection Volume to Capacity – Scenario 8

<u>Intersection</u>	<u>Movement</u>	<u>AM Peak Hour Background Plus Project Traffic</u>			<u>PM Peak Hour Background Plus Project Traffic</u>		
		<u>Left</u>	<u>Through</u>	<u>Right</u>	<u>Left</u>	<u>Through</u>	<u>Right</u>
US 19 and Spring Hill Drive	EB	0.58	0.42	0.34	0.64	0.53	0.18
	WB	0.86	0.58	0.62	0.79	0.58	0.90
	NB	0.54	0.47	0.27	0.65	0.71	0.34
	SB	0.70	0.46	0.06	0.80	0.43	0.09
US 19 and Osowaw Boulevard/Driveway B	EB	-	-	0.03	-	-	0.04
	WB	0.44	-	0.12	0.96	-	0.38
	NB	-	*	*	-	*	*
	SB	0.19	*	*	0.28	*	*
Spring Hill Drive and Pinehurst Drive	EB	-	*	*	-	*	*
	WB	0.09	*	*	0.08	*	*
	NB	-	-	0.09	-	-	0.28
	SB	0.64	0.64	0.64	0.66	0.66	0.66

* Free flow movement

APPENDIX

APPENDIX
CONCEPTUAL SITE PLAN

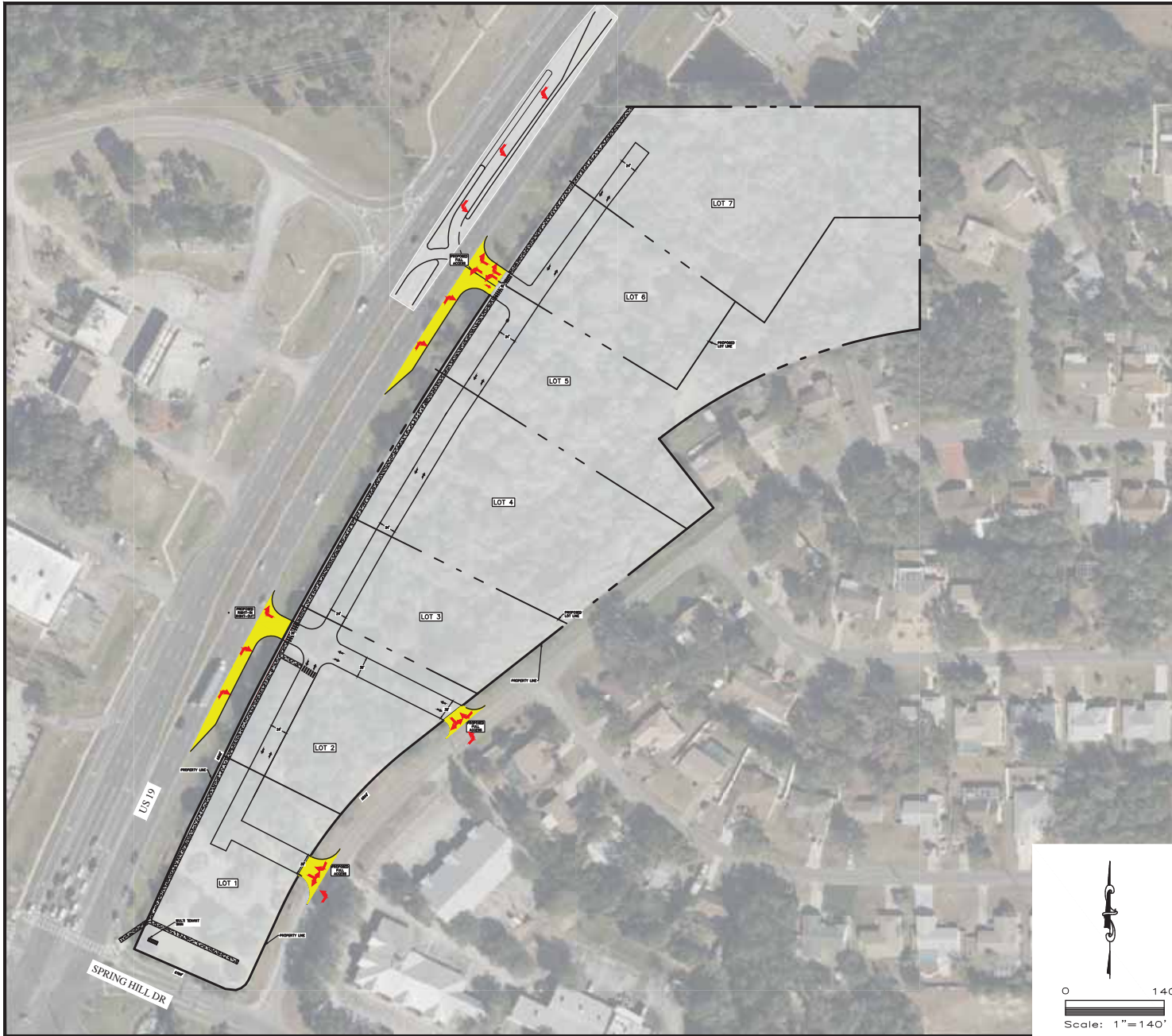

GENERAL SITE NOTES:

1. SIGNS REQUIRE A SEPARATE PERMIT.
2. DUMPSTERS AND MECHANICAL EQUIPMENT WILL BE SCREENED FROM THE PUBLIC.
3. WALLS OVER 6' HIGH APPROVED BY SEPARATE PERMIT.
4. PARKING WILL BE PAVED.
5. PARKING WILL BE WITHIN 60' OF BUILDING.
6. THERE SHALL BE NO OBSTRUCTION OF SITE SIGNAGE BY LANDSCAPE PLANT MATERIAL AND SUCH MUST BE RELOCATED/CONNECTED BEFORE THE FIELD INSPECTION WILL ACCEPT/PASS THE SIGN IN THE FIELD OR ISSUE A CERTIFICATE OF OCCUPANCY FOR A PROJECT.
7. ALL ROOF MOUNTED MECHANICAL EQUIPMENT SHALL BE FULLY SCREENED BY PARAPET WALLS EQUAL TO, OR GREATER THAN, THE HIGHEST POINT ON THE MECHANICAL EQUIPMENT.
8. SOLID MASONRY WALLS AND GATES EQUAL TO, OR GREATER THAN, THE HIGHEST POINT ON THE MECHANICAL EQUIPMENT SHALL SCREEN ALL GROUND MOUNTED MECHANICAL EQUIPMENT.
9. ALL SITE IMPROVEMENTS, INCLUDING LANDSCAPE AND SITE CLEANUP, MUST BE COMPLETED PRIOR TO CERTIFICATE OF OCCUPANCY FOR ANY BUILDING WITHIN A PHASE.
10. THE FIRE DEPT. DOUBLE CHECK ASSEMBLY SHALL BE PAINTED TO MATCH ADJACENT WALL COLOR.
11. ALL EXTERNAL LIGHTING SHALL BE LOCATED AND DESIGNED TO PREVENT RAYS FROM BEING DIRECTED OFF OF THE PROPERTY UPON WHICH THE LIGHTING IS LOCATED.
12. CONDITIONS MAY EXIST THAT COULD RESTRICT THE DEVELOPMENT OF THE SITE AS SHOWN, THE DRAWING IS INTENDED TO BE CONCEPTUAL ONLY AND ADDITIONAL RESEARCH AND DESIGN WOULD BE REQUIRED FOR THE PREPARATION OF A PERMIT THAT MEETS LOCAL JURISDICTIONAL CODES.
13. BCG DOES NOT PURPORT THAT THE SITE CAN BE DEVELOPED AS SHOWN, THE PURCHASE OF THIS SITE SHALL BE AT THE OWNER'S SOLE RISK AND EXPENSE.
14. STORMWATER MANAGEMENT FACILITY SHOWN ON THIS PLAN ARE PURELY CONCEPTUAL AND IS SUBJECT TO CHANGE UPON FINAL CIVIL DESIGN. BCG DOES NOT PURPORT THAT WHAT IS SHOWN IS ADEQUATE TO MEET ALL JURISDICTIONAL REQUIREMENTS.
15. NO SITE VISITS HAVE BEEN PERFORMED TO ENSURE THE ACCURACY OF THE AERIAL IMAGE SHOWN HEREON.
16. THIS EXHIBIT IS NOT INTENDED TO BE USED AS A CONSTRUCTION DOCUMENT, AND SHOULD NOT BE CONSTRUED IN ANYWAY TO BE USED FOR CONSTRUCTION PURPOSES.

PROPOSED LEGEND

	PROPERTY LINE
	BUILDING SETBACK LINE
	LANDSCAPE BUFFER
	PARKING COUNT

Bowman Consulting Group, Ltd.
 1410 N. Wesslake Blvd
 Tampa, FL 33607
 Phone: (813) 474-7424
 www.bowmanconsulting.com
 © Bowman Consulting Group, Ltd.

CONCEPTUAL DESIGN
 HERNANDO COUNTY QSR
 US 19 & SPRING HILL DR
 SPRING HILL, FL 34606

Bowman
 CONSULTING
 Certificate of Authorization License No. 34462

BGG	BGG	MS
DESIGN	DRAWING	CHECKED
011031-01-001		
PROJECT NUMBER		
SCALE 1" = 140'		
VERSION	11 D	

APPENDIX
TRIP GENERATION

PERIOD SETTING

Analysis Name : Daily
Project Name : US 19 and Spring Hill Dr - Rev Uses V2 **No :**
Date: 8/3/2022 **City:**
State/Province: **Zip/Postal Code:**
Country: **Client Name:**
Analyst's Name: **Edition:** Trip Generation Manual, 11th Ed

Land Use	Independent Variable	Size	Time Period	Method	Entry	Exit	Total
945 - Convenience Store/Gas Station - GFA (5.5-10k) (General Urban/Suburban)	Vehicle Fueling Positions	20 ⁽⁰⁾	Weekday	Average 345.75	3458 ⁽¹⁾ 50%	3457 ⁽¹⁾ 50%	6915 ⁽¹⁾
934 - Fast-Food Restaurant with Drive-Through Window (General Urban/Suburban)	1000 Sq. Ft. GFA	2.5	Weekday	Average 467.48	585 50%	584 50%	1169
720 - Medical-Dental Office Building - Stand-Alone (General Urban/Suburban)	1000 Sq. Ft. GFA	5	Weekday	Average 36	90 50%	90 50%	180
720 - Medical-Dental Office Building - 1 - Stand-Alone (General Urban/Suburban)	1000 Sq. Ft. GFA	5	Weekday	Average 36	90 50%	90 50%	180
932 - High-Turnover (Sit-Down) Restaurant (General Urban/Suburban)	1000 Sq. Ft. GFA	6	Weekday	Average 107.2	322 50%	321 50%	643
822 - Strip Retail Plaza (<40k) - 2 (General Urban/Suburban)	1000 Sq. Ft. GLA	7 ⁽⁰⁾	Weekday	Average 54.45	191 ⁽¹⁾ 50%	190 ⁽¹⁾ 50%	381 ⁽¹⁾

⁽⁰⁾ indicates size out of range.
⁽¹⁾ indicates small sample size, use carefully.

TRAFFIC REDUCTIONS

Land Use	Entry Reduction	Adjusted Entry	Exit Reduction	Adjusted Exit
945 - Convenience Store/Gas Station	0 %	3458	0 %	3457
934 - Fast-Food Restaurant with Drive-Through Window	0 %	585	0 %	584
720 - Medical-Dental Office Building	0 %	90	0 %	90
720 - Medical-Dental Office Building - 1	0 %	90	0 %	90
932 - High-Turnover (Sit-Down) Restaurant	0 %	322	0 %	321
822 - Strip Retail Plaza (<40k) - 2	0 %	191	0 %	190

INTERNAL TRIPS

945 - Convenience Store/Gas Station				934 - Fast-Food Restaurant with Drive-Through Window			
Exit	3457	Demand Exit:	0 % (0)	Balanced:	0	Demand Entry:	0 % (0)
Entry	3458	Demand Entry:	0 % (0)	Balanced:	0	Demand Exit:	0 % (0)
Exit	3457	Demand Exit:	0 % (0)	Balanced:	0	Demand Entry:	0 % (0)
Entry	3458	Demand Entry:	0 % (0)	Balanced:	0	Demand Exit:	0 % (0)
945 - Convenience Store/Gas Station				720 - Medical-Dental Office Building			
Exit	3457	Demand Exit:	0 % (0)	Balanced:	0	Demand Entry:	0 % (0)
Entry	3458	Demand Entry:	0 % (0)	Balanced:	0	Demand Exit:	0 % (0)
945 - Convenience Store/Gas Station				720 - Medical-Dental Office Building - 1			

Exit	3457	Demand Exit: 0 % (0)	Balanced: 0	Demand Entry: 0 % (0)	Entry	90
Entry	3458	Demand Entry: 0 % (0)	Balanced: 0	Demand Exit: 0 % (0)	Exit	90
945 - Convenience Store/Gas Station				932 - High-Turnover (Sit-Down) Restaurant		
Exit	3457	Demand Exit: 0 % (0)	Balanced: 0	Demand Entry: 0 % (0)	Entry	322
Entry	3458	Demand Entry: 0 % (0)	Balanced: 0	Demand Exit: 0 % (0)	Exit	321
945 - Convenience Store/Gas Station				822 - Strip Retail Plaza (&lt;40k) - 2		
Exit	3457	Demand Exit: 0 % (0)	Balanced: 0	Demand Entry: 0 % (0)	Entry	191
Entry	3458	Demand Entry: 0 % (0)	Balanced: 0	Demand Exit: 0 % (0)	Exit	190
934 - Fast-Food Restaurant with Drive-Through Window				720 - Medical-Dental Office Building		
Exit	584	Demand Exit: 0 % (0)	Balanced: 0	Demand Entry: 0 % (0)	Entry	90
Entry	585	Demand Entry: 0 % (0)	Balanced: 0	Demand Exit: 0 % (0)	Exit	90
934 - Fast-Food Restaurant with Drive-Through Window				720 - Medical-Dental Office Building - 1		
Exit	584	Demand Exit: 0 % (0)	Balanced: 0	Demand Entry: 0 % (0)	Entry	90
Entry	585	Demand Entry: 0 % (0)	Balanced: 0	Demand Exit: 0 % (0)	Exit	90
934 - Fast-Food Restaurant with Drive-Through Window				932 - High-Turnover (Sit-Down) Restaurant		
Exit	584	Demand Exit: 0 % (0)	Balanced: 0	Demand Entry: 0 % (0)	Entry	322
Entry	585	Demand Entry: 0 % (0)	Balanced: 0	Demand Exit: 0 % (0)	Exit	321
934 - Fast-Food Restaurant with Drive-Through Window				822 - Strip Retail Plaza (&lt;40k) - 2		
Exit	584	Demand Exit: 0 % (0)	Balanced: 0	Demand Entry: 0 % (0)	Entry	191
Entry	585	Demand Entry: 0 % (0)	Balanced: 0	Demand Exit: 0 % (0)	Exit	190
720 - Medical-Dental Office Building				720 - Medical-Dental Office Building - 1		
Exit	90	Demand Exit: 0 % (0)	Balanced: 0	Demand Entry: 0 % (0)	Entry	90
Entry	90	Demand Entry: 0 % (0)	Balanced: 0	Demand Exit: 0 % (0)	Exit	90
720 - Medical-Dental Office Building				932 - High-Turnover (Sit-Down) Restaurant		
Exit	90	Demand Exit: 0 % (0)	Balanced: 0	Demand Entry: 0 % (0)	Entry	322
Entry	90	Demand Entry: 0 % (0)	Balanced: 0	Demand Exit: 0 % (0)	Exit	321
720 - Medical-Dental Office Building				822 - Strip Retail Plaza (&lt;40k) - 2		
Exit	90	Demand Exit: 0 % (0)	Balanced: 0	Demand Entry: 0 % (0)	Entry	191
Entry	90	Demand Entry: 0 % (0)	Balanced: 0	Demand Exit: 0 % (0)	Exit	190
720 - Medical-Dental Office Building - 1				932 - High-Turnover (Sit-Down) Restaurant		
Exit	90	Demand Exit: 0 % (0)	Balanced: 0	Demand Entry: 0 % (0)	Entry	322
Entry	90	Demand Entry: 0 % (0)	Balanced: 0	Demand Exit: 0 % (0)	Exit	321
720 - Medical-Dental Office Building - 1				822 - Strip Retail Plaza (&lt;40k) - 2		
Exit	90	Demand Exit: 0 % (0)	Balanced: 0	Demand Entry: 0 % (0)	Entry	191
Entry	90	Demand Entry: 0 % (0)	Balanced: 0	Demand Exit: 0 % (0)	Exit	190
932 - High-Turnover (Sit-Down) Restaurant				822 - Strip Retail Plaza (&lt;40k) - 2		
Exit	321	Demand Exit: 0 % (0)	Balanced: 0	Demand Entry: 0 % (0)	Entry	191
Entry	322	Demand Entry: 0 % (0)	Balanced: 0	Demand Exit: 0 % (0)	Exit	190
945 - Convenience Store/Gas Station						

	Total Trips	Internal Trips					Total	External Trips
		934 - Fast-Food Restaurant with Drive-Through Window	720 - Medical-Dental Office Building	720 - Medical-Dental Office Building - 1	932 - High-Turnover (Sit-Down) Restaurant	822 - Strip Retail Plaza (&it;40k) - 2		
Entry	3458 (100%)	0 (0%)	0 (0%)	0 (0%)	0 (0%)	0 (0%)	0 (0%)	3458 (100%)
Exit	3457 (100%)	0 (0%)	0 (0%)	0 (0%)	0 (0%)	0 (0%)	0 (0%)	3457 (100%)
Total	6915 (100%)	0 (0%)	0 (0%)	0 (0%)	0 (0%)	0 (0%)	0 (0%)	6915 (100%)

934 - Fast-Food Restaurant with Drive-Through Window

	Total Trips	Internal Trips					Total	External Trips
		945 - Convenience Store/Gas Station	720 - Medical-Dental Office Building	720 - Medical-Dental Office Building - 1	932 - High-Turnover (Sit-Down) Restaurant	822 - Strip Retail Plaza (&it;40k) - 2		
Entry	585 (100%)	0 (0%)	0 (0%)	0 (0%)	0 (0%)	0 (0%)	0 (0%)	585 (100%)
Exit	584 (100%)	0 (0%)	0 (0%)	0 (0%)	0 (0%)	0 (0%)	0 (0%)	584 (100%)
Total	1169 (100%)	0 (0%)	0 (0%)	0 (0%)	0 (0%)	0 (0%)	0 (0%)	1169 (100%)

720 - Medical-Dental Office Building

	Total Trips	Internal Trips					Total	External Trips
		945 - Convenience Store/Gas Station	934 - Fast-Food Restaurant with Drive-Through Window	720 - Medical-Dental Office Building - 1	932 - High-Turnover (Sit-Down) Restaurant	822 - Strip Retail Plaza (&it;40k) - 2		
Entry	90 (100%)	0 (0%)	0 (0%)	0 (0%)	0 (0%)	0 (0%)	0 (0%)	90 (100%)
Exit	90 (100%)	0 (0%)	0 (0%)	0 (0%)	0 (0%)	0 (0%)	0 (0%)	90 (100%)
Total	180 (100%)	0 (0%)	0 (0%)	0 (0%)	0 (0%)	0 (0%)	0 (0%)	180 (100%)

720 - Medical-Dental Office Building - 1

	Total Trips	Internal Trips					Total	External Trips
		945 - Convenience Store/Gas Station	934 - Fast-Food Restaurant with Drive-Through Window	720 - Medical-Dental Office Building	932 - High-Turnover (Sit-Down) Restaurant	822 - Strip Retail Plaza (&it;40k) - 2		
Entry	90 (100%)	0 (0%)	0 (0%)	0 (0%)	0 (0%)	0 (0%)	0 (0%)	90 (100%)
Exit	90 (100%)	0 (0%)	0 (0%)	0 (0%)	0 (0%)	0 (0%)	0 (0%)	90 (100%)
Total	180 (100%)	0 (0%)	0 (0%)	0 (0%)	0 (0%)	0 (0%)	0 (0%)	180 (100%)

932 - High-Turnover (Sit-Down) Restaurant

	Total Trips	Internal Trips					Total	External Trips
		945 - Convenience Store/Gas Station	934 - Fast-Food Restaurant with Drive-Through Window	720 - Medical-Dental Office Building	720 - Medical-Dental Office Building - 1	822 - Strip Retail Plaza (&it;40k) - 2		
Entry	322 (100%)	0 (0%)	0 (0%)	0 (0%)	0 (0%)	0 (0%)	0 (0%)	322 (100%)
Exit	321 (100%)	0 (0%)	0 (0%)	0 (0%)	0 (0%)	0 (0%)	0 (0%)	321 (100%)
Total	643 (100%)	0 (0%)	0 (0%)	0 (0%)	0 (0%)	0 (0%)	0 (0%)	643 (100%)

822 - Strip Retail Plaza (&it;40k) - 2

	Total Trips	Internal Trips					Total	External Trips
		945 - Convenience Store/Gas Station	934 - Fast-Food Restaurant with Drive-Through Window	720 - Medical-Dental Office Building	720 - Medical-Dental Office Building - 1	932 - High-Turnover (Sit-Down) Restaurant		
Entry	191 (100%)	0 (0%)	0 (0%)	0 (0%)	0 (0%)	0 (0%)	0 (0%)	191 (100%)
Exit	190 (100%)	0 (0%)	0 (0%)	0 (0%)	0 (0%)	0 (0%)	0 (0%)	190 (100%)
Total	381 (100%)	0 (0%)	0 (0%)	0 (0%)	0 (0%)	0 (0%)	0 (0%)	381 (100%)

EXTERNAL TRIPS

PERIOD SETTING

Analysis Name : AM Peak Hour
Project Name : US 19 and Spring Hill Dr - Rev Uses V2 **No :**
Date: 8/3/2022 **City:**
State/Province: **Zip/Postal Code:**
Country: **Client Name:**
Analyst's Name: **Edition:** Trip Generation Manual, 11th Ed

Land Use	Independent Variable	Size	Time Period	Method	Entry	Exit	Total
945 - Convenience Store/Gas Station - GFA (5.5-10k) (General Urban/Suburban)	Vehicle Fueling Positions	20	Weekday, Peak Hour of Adjacent Street Traffic, One Hour Between 7 and 9 a.m.	Average 31.6	316 50%	316 50%	632
934 - Fast-Food Restaurant with Drive-Through Window (General Urban/Suburban)	1000 Sq. Ft. GFA	2.5	Weekday, Peak Hour of Adjacent Street Traffic, One Hour Between 7 and 9 a.m.	Average 44.61	57 51%	55 49%	112
720 - Medical-Dental Office Building - Stand-Alone (General Urban/Suburban)	1000 Sq. Ft. GFA	5	Weekday, Peak Hour of Adjacent Street Traffic, One Hour Between 7 and 9 a.m.	Best Fit (LOG) $\ln(T) = 0.9\ln(X) + 1.34$	13 81%	3 19%	16
720 - Medical-Dental Office Building - 1 - Stand-Alone (General Urban/Suburban)	1000 Sq. Ft. GFA	5	Weekday, Peak Hour of Adjacent Street Traffic, One Hour Between 7 and 9 a.m.	Best Fit (LOG) $\ln(T) = 0.9\ln(X) + 1.34$	13 81%	3 19%	16
932 - High-Turnover (Sit-Down) Restaurant (General Urban/Suburban)	1000 Sq. Ft. GFA	6	Weekday, Peak Hour of Adjacent Street Traffic, One Hour Between 7 and 9 a.m.	Average 9.57	31 54%	26 46%	57
822 - Strip Retail Plaza (<lt;40k) - 2 (General Urban/Suburban)	1000 Sq. Ft. GLA	7 ⁽⁰⁾	Weekday, Peak Hour of Adjacent Street Traffic, One Hour Between 7 and 9 a.m.	Average 2.36	10 ⁽¹⁾ 59%	7 ⁽¹⁾ 41%	17 ⁽¹⁾

(0) indicates size out of range.
 (1) indicates small sample size, use carefully.

TRAFFIC REDUCTIONS

Land Use	Entry Reduction	Adjusted Entry	Exit Reduction	Adjusted Exit
945 - Convenience Store/Gas Station	0 %	316	0 %	316
934 - Fast-Food Restaurant with Drive-Through Window	0 %	57	0 %	55
720 - Medical-Dental Office Building	0 %	13	0 %	3
720 - Medical-Dental Office Building - 1	0 %	13	0 %	3
932 - High-Turnover (Sit-Down) Restaurant	0 %	31	0 %	26
822 - Strip Retail Plaza (<lt;40k) - 2	0 %	10	0 %	7

INTERNAL TRIPS

945 - Convenience Store/Gas Station			934 - Fast-Food Restaurant with Drive-Through Window		
Exit	316	Demand Exit: 0 % (0)	Balanced:	Demand Entry: 0 % (0)	Entry 57

			0		
Entry	316	Demand Entry: 0 % (0)	Balanced: 0	Demand Exit: 0 % (0)	Exit 55
945 - Convenience Store/Gas Station				720 - Medical-Dental Office Building	
Exit	316	Demand Exit: 0 % (0)	Balanced: 0	Demand Entry: 0 % (0)	Entry 13
Entry	316	Demand Entry: 0 % (0)	Balanced: 0	Demand Exit: 0 % (0)	Exit 3
945 - Convenience Store/Gas Station				720 - Medical-Dental Office Building - 1	
Exit	316	Demand Exit: 0 % (0)	Balanced: 0	Demand Entry: 0 % (0)	Entry 13
Entry	316	Demand Entry: 0 % (0)	Balanced: 0	Demand Exit: 0 % (0)	Exit 3
945 - Convenience Store/Gas Station				932 - High-Turnover (Sit-Down) Restaurant	
Exit	316	Demand Exit: 0 % (0)	Balanced: 0	Demand Entry: 0 % (0)	Entry 31
Entry	316	Demand Entry: 0 % (0)	Balanced: 0	Demand Exit: 0 % (0)	Exit 26
945 - Convenience Store/Gas Station				822 - Strip Retail Plaza (&lt;lt;lt;40k) - 2	
Exit	316	Demand Exit: 0 % (0)	Balanced: 0	Demand Entry: 0 % (0)	Entry 10
Entry	316	Demand Entry: 0 % (0)	Balanced: 0	Demand Exit: 0 % (0)	Exit 7
934 - Fast-Food Restaurant with Drive-Through Window				720 - Medical-Dental Office Building	
Exit	55	Demand Exit: 0 % (0)	Balanced: 0	Demand Entry: 0 % (0)	Entry 13
Entry	57	Demand Entry: 0 % (0)	Balanced: 0	Demand Exit: 0 % (0)	Exit 3
934 - Fast-Food Restaurant with Drive-Through Window				720 - Medical-Dental Office Building - 1	
Exit	55	Demand Exit: 0 % (0)	Balanced: 0	Demand Entry: 0 % (0)	Entry 13
Entry	57	Demand Entry: 0 % (0)	Balanced: 0	Demand Exit: 0 % (0)	Exit 3
934 - Fast-Food Restaurant with Drive-Through Window				932 - High-Turnover (Sit-Down) Restaurant	
Exit	55	Demand Exit: 0 % (0)	Balanced: 0	Demand Entry: 0 % (0)	Entry 31
Entry	57	Demand Entry: 0 % (0)	Balanced: 0	Demand Exit: 0 % (0)	Exit 26
934 - Fast-Food Restaurant with Drive-Through Window				822 - Strip Retail Plaza (&lt;lt;lt;40k) - 2	
Exit	55	Demand Exit: 0 % (0)	Balanced: 0	Demand Entry: 0 % (0)	Entry 10
Entry	57	Demand Entry: 0 % (0)	Balanced: 0	Demand Exit: 0 % (0)	Exit 7
720 - Medical-Dental Office Building				720 - Medical-Dental Office Building - 1	
Exit	3	Demand Exit: 0 % (0)	Balanced: 0	Demand Entry: 0 % (0)	Entry 13
Entry	13	Demand Entry: 0 % (0)	Balanced: 0	Demand Exit: 0 % (0)	Exit 3
720 - Medical-Dental Office Building				932 - High-Turnover (Sit-Down) Restaurant	
Exit	3	Demand Exit: 0 % (0)	Balanced: 0	Demand Entry: 0 % (0)	Entry 31
Entry	13	Demand Entry: 0 % (0)	Balanced: 0	Demand Exit: 0 % (0)	Exit 26
720 - Medical-Dental Office Building				822 - Strip Retail Plaza (&lt;lt;lt;40k) - 2	
Exit	3	Demand Exit: 0 % (0)	Balanced: 0	Demand Entry: 0 % (0)	Entry 10
Entry	13	Demand Entry: 0 % (0)	Balanced: 0	Demand Exit: 0 % (0)	Exit 7
720 - Medical-Dental Office Building - 1				932 - High-Turnover (Sit-Down) Restaurant	
Exit	3	Demand Exit: 0 % (0)	Balanced: 0	Demand Entry: 0 % (0)	Entry 31
Entry	13	Demand Entry: 0 % (0)	Balanced: 0	Demand Exit: 0 % (0)	Exit 26

720 - Medical-Dental Office Building - 1

Exit 3 Demand Exit: 0 % (0)
 Entry 13 Demand Entry: 0 % (0)

Balanced:
0
 Balanced:
0

822 - Strip Retail Plaza (&lt;40k) - 2

Demand Entry: 0 % (0) Entry 10
 Demand Exit: 0 % (0) Exit 7

932 - High-Turnover (Sit-Down) Restaurant

Exit 26 Demand Exit: 0 % (0)
 Entry 31 Demand Entry: 0 % (0)

Balanced:
0
 Balanced:
0

822 - Strip Retail Plaza (&lt;40k) - 2

Demand Entry: 0 % (0) Entry 10
 Demand Exit: 0 % (0) Exit 7

945 - Convenience Store/Gas Station

	Total Trips	Internal Trips					Total	External Trips
		934 - Fast-Food Restaurant with Drive-Through Window	720 - Medical-Dental Office Building	720 - Medical-Dental Office Building - 1	932 - High-Turnover (Sit-Down) Restaurant	822 - Strip Retail Plaza (&lt;40k) - 2		
Entry	316 (100%)	0 (0%)	0 (0%)	0 (0%)	0 (0%)	0 (0%)	0 (0%)	316 (100%)
Exit	316 (100%)	0 (0%)	0 (0%)	0 (0%)	0 (0%)	0 (0%)	0 (0%)	316 (100%)
Total	632 (100%)	0 (0%)	0 (0%)	0 (0%)	0 (0%)	0 (0%)	0 (0%)	632 (100%)

934 - Fast-Food Restaurant with Drive-Through Window

	Total Trips	Internal Trips					Total	External Trips
		945 - Convenience Store/Gas Station	720 - Medical-Dental Office Building	720 - Medical-Dental Office Building - 1	932 - High-Turnover (Sit-Down) Restaurant	822 - Strip Retail Plaza (&lt;40k) - 2		
Entry	57 (100%)	0 (0%)	0 (0%)	0 (0%)	0 (0%)	0 (0%)	0 (0%)	57 (100%)
Exit	55 (100%)	0 (0%)	0 (0%)	0 (0%)	0 (0%)	0 (0%)	0 (0%)	55 (100%)
Total	112 (100%)	0 (0%)	0 (0%)	0 (0%)	0 (0%)	0 (0%)	0 (0%)	112 (100%)

720 - Medical-Dental Office Building

	Total Trips	Internal Trips					Total	External Trips
		945 - Convenience Store/Gas Station	934 - Fast-Food Restaurant with Drive-Through Window	720 - Medical-Dental Office Building - 1	932 - High-Turnover (Sit-Down) Restaurant	822 - Strip Retail Plaza (&lt;40k) - 2		
Entry	13 (100%)	0 (0%)	0 (0%)	0 (0%)	0 (0%)	0 (0%)	0 (0%)	13 (100%)
Exit	3 (100%)	0 (0%)	0 (0%)	0 (0%)	0 (0%)	0 (0%)	0 (0%)	3 (100%)
Total	16 (100%)	0 (0%)	0 (0%)	0 (0%)	0 (0%)	0 (0%)	0 (0%)	16 (100%)

720 - Medical-Dental Office Building - 1

	Total Trips	Internal Trips					Total	External Trips
		945 - Convenience Store/Gas Station	934 - Fast-Food Restaurant with Drive-Through Window	720 - Medical-Dental Office Building	932 - High-Turnover (Sit-Down) Restaurant	822 - Strip Retail Plaza (&lt;40k) - 2		
Entry	13 (100%)	0 (0%)	0 (0%)	0 (0%)	0 (0%)	0 (0%)	0 (0%)	13 (100%)
Exit	3 (100%)	0 (0%)	0 (0%)	0 (0%)	0 (0%)	0 (0%)	0 (0%)	3 (100%)
Total	16 (100%)	0 (0%)	0 (0%)	0 (0%)	0 (0%)	0 (0%)	0 (0%)	16 (100%)

932 - High-Turnover (Sit-Down) Restaurant

	Total Trips	Internal Trips					Total	External Trips
		945 - Convenience Store/Gas Station	934 - Fast-Food Restaurant with Drive-Through Window	720 - Medical-Dental Office Building	720 - Medical-Dental Office Building - 1	822 - Strip Retail Plaza (&lt;40k) - 2		
Entry	31 (100%)	0 (0%)	0 (0%)	0 (0%)	0 (0%)	0 (0%)	0 (0%)	31 (100%)
Exit	26 (100%)	0 (0%)	0 (0%)	0 (0%)	0 (0%)	0 (0%)	0 (0%)	26 (100%)
Total	57 (100%)	0 (0%)	0 (0%)	0 (0%)	0 (0%)	0 (0%)	0 (0%)	57 (100%)

822 - Strip Retail Plaza (&lt;40k) - 2

Total Trips	Internal Trips	External Trips

		945 - Convenience Store/Gas Station	934 - Fast-Food Restaurant with Drive-Through Window	720 - Medical-Dental Office Building	720 - Medical-Dental Office Building - 1	932 - High-Turnover (Sit-Down) Restaurant	Total	
Entry	10 (100%)	0 (0%)	0 (0%)	0 (0%)	0 (0%)	0 (0%)	0 (0%)	10 (100%)
Exit	7 (100%)	0 (0%)	0 (0%)	0 (0%)	0 (0%)	0 (0%)	0 (0%)	7 (100%)
Total	17 (100%)	0 (0%)	0 (0%)	0 (0%)	0 (0%)	0 (0%)	0 (0%)	17 (100%)

EXTERNAL TRIPS

Land Use	External Trips	Pass-by%	Pass-by Trips	Non-pass-by Trips
945 - Convenience Store/Gas Station	632	76	480	152
934 - Fast-Food Restaurant with Drive-Through Window	112	50	56	56
720 - Medical-Dental Office Building	16	0	0	16
720 - Medical-Dental Office Building - 1	16	0	0	16
932 - High-Turnover (Sit-Down) Restaurant	57	43	25	32
822 - Strip Retail Plaza (<lt;40k) - 2	17	40	7	10

ITE DEVIATION DETAILS

Weekday, Peak Hour of Adjacent Street Traffic, One Hour Between 7 and 9 a.m.

Landuse No deviations from ITE.

Methods No deviations from ITE.

External Trips 945 - Convenience Store/Gas Station - GFA (5.5-10k) (General Urban/Suburban)
ITE does not recommend a particular pass-by% for this case.

934 - Fast-Food Restaurant with Drive-Through Window (General Urban/Suburban)
ITE does not recommend a particular pass-by% for this case.

720 - Medical-Dental Office Building - Stand-Alone (General Urban/Suburban)
ITE does not recommend a particular pass-by% for this case.

720 - Medical-Dental Office Building - 1 - Stand-Alone (General Urban/Suburban)
ITE does not recommend a particular pass-by% for this case.

932 - High-Turnover (Sit-Down) Restaurant (General Urban/Suburban)
ITE does not recommend a particular pass-by% for this case.

822 - Strip Retail Plaza (<lt;40k) - 2 (General Urban/Suburban)
ITE does not recommend a particular pass-by% for this case.

SUMMARY

Total Entering	440
Total Exiting	410
Total Entering Reduction	0
Total Exiting Reduction	0
Total Entering Internal Capture Reduction	0
Total Exiting Internal Capture Reduction	0
Total Entering Pass-by Reduction	285
Total Exiting Pass-by Reduction	283
Total Entering Non-Pass-by Trips	155
Total Exiting Non-Pass-by Trips	127

0

945 - Convenience Store/Gas Station

Exit 269 Demand Exit: 0 % (0)

Entry 269 Demand Entry: 0 % (0)

945 - Convenience Store/Gas Station

Exit 269 Demand Exit: 0 % (0)

Entry 269 Demand Entry: 0 % (0)

945 - Convenience Store/Gas Station

Exit 269 Demand Exit: 0 % (0)

Entry 269 Demand Entry: 0 % (0)

945 - Convenience Store/Gas Station

Exit 269 Demand Exit: 0 % (0)

Entry 269 Demand Entry: 0 % (0)

934 - Fast-Food Restaurant with Drive-Through Window

Exit 40 Demand Exit: 0 % (0)

Entry 43 Demand Entry: 0 % (0)

934 - Fast-Food Restaurant with Drive-Through Window

Exit 40 Demand Exit: 0 % (0)

Entry 43 Demand Entry: 0 % (0)

934 - Fast-Food Restaurant with Drive-Through Window

Exit 40 Demand Exit: 0 % (0)

Entry 43 Demand Entry: 0 % (0)

934 - Fast-Food Restaurant with Drive-Through Window

Exit 40 Demand Exit: 0 % (0)

Entry 43 Demand Entry: 0 % (0)

720 - Medical-Dental Office Building

Exit 12 Demand Exit: 0 % (0)

Entry 5 Demand Entry: 0 % (0)

720 - Medical-Dental Office Building

Exit 12 Demand Exit: 0 % (0)

Entry 5 Demand Entry: 0 % (0)

720 - Medical-Dental Office Building

Exit 12 Demand Exit: 0 % (0)

Entry 5 Demand Entry: 0 % (0)

720 - Medical-Dental Office Building - 1

Exit 12 Demand Exit: 0 % (0)

Entry 5 Demand Entry: 0 % (0)

720 - Medical-Dental Office Building - 1

720 - Medical-Dental Office Building

Demand Entry: 0 % (0) Entry 5

Demand Exit: 0 % (0) Exit 12

720 - Medical-Dental Office Building - 1

Demand Entry: 0 % (0) Entry 5

Demand Exit: 0 % (0) Exit 12

932 - High-Turnover (Sit-Down) Restaurant

Demand Entry: 0 % (0) Entry 33

Demand Exit: 0 % (0) Exit 21

822 - Strip Retail Plaza (&lt;40k) - 2

Demand Entry: 0 % (0) Entry 30

Demand Exit: 0 % (0) Exit 30

720 - Medical-Dental Office Building

Demand Entry: 0 % (0) Entry 5

Demand Exit: 0 % (0) Exit 12

720 - Medical-Dental Office Building - 1

Demand Entry: 0 % (0) Entry 5

Demand Exit: 0 % (0) Exit 12

932 - High-Turnover (Sit-Down) Restaurant

Demand Entry: 0 % (0) Entry 33

Demand Exit: 0 % (0) Exit 21

822 - Strip Retail Plaza (&lt;40k) - 2

Demand Entry: 0 % (0) Entry 30

Demand Exit: 0 % (0) Exit 30

720 - Medical-Dental Office Building - 1

Demand Entry: 0 % (0) Entry 5

Demand Exit: 0 % (0) Exit 12

932 - High-Turnover (Sit-Down) Restaurant

Demand Entry: 0 % (0) Entry 33

Demand Exit: 0 % (0) Exit 21

822 - Strip Retail Plaza (&lt;40k) - 2

Demand Entry: 0 % (0) Entry 30

Demand Exit: 0 % (0) Exit 30

932 - High-Turnover (Sit-Down) Restaurant

Demand Entry: 0 % (0) Entry 33

Demand Exit: 0 % (0) Exit 21

822 - Strip Retail Plaza (&lt;40k) - 2

Balanced: 0

Balanced: 0

Balanced: 0

Balanced: 0

Balanced: 0

Balanced: 0

Balanced: 0

Balanced: 0

Balanced: 0

Balanced: 0

Balanced: 0

Balanced: 0

Balanced: 0

Balanced: 0

Balanced: 0

Balanced: 0

Balanced: 0

Balanced: 0

Balanced: 0

Balanced: 0

Balanced: 0

Balanced: 0

Balanced: 0

Balanced: 0

		Store/Gas Station	Restaurant with Drive-Through Window	Dental Office Building	Dental Office Building - 1	Down) Restaurant		
Entry	30 (100%)	0 (0%)	0 (0%)	0 (0%)	0 (0%)	0 (0%)	0 (0%)	30 (100%)
Exit	30 (100%)	0 (0%)	0 (0%)	0 (0%)	0 (0%)	0 (0%)	0 (0%)	30 (100%)
Total	60 (100%)	0 (0%)	0 (0%)	0 (0%)	0 (0%)	0 (0%)	0 (0%)	60 (100%)

EXTERNAL TRIPS

Land Use	External Trips	Pass-by%	Pass-by Trips	Non-pass-by Trips
945 - Convenience Store/Gas Station	538	75	404	134
934 - Fast-Food Restaurant with Drive-Through Window	83	55	46	37
720 - Medical-Dental Office Building	17	0	0	17
720 - Medical-Dental Office Building - 1	17	0	0	17
932 - High-Turnover (Sit-Down) Restaurant	54	43	23	31
822 - Strip Retail Plaza (<40k) - 2	60	40	24	36

ITE DEVIATION DETAILS

Weekday, Peak Hour of Adjacent Street Traffic, One Hour Between 4 and 6 p.m.

Landuse No deviations from ITE.

Methods No deviations from ITE.

External Trips 945 - Convenience Store/Gas Station - GFA (5.5-10k) (General Urban/Suburban)
ITE does not recommend a particular pass-by% for this case.

934 - Fast-Food Restaurant with Drive-Through Window (General Urban/Suburban)
ITE does not recommend a particular pass-by% for this case.

720 - Medical-Dental Office Building - Stand-Alone (General Urban/Suburban)
ITE does not recommend a particular pass-by% for this case.

720 - Medical-Dental Office Building - 1 - Stand-Alone (General Urban/Suburban)
ITE does not recommend a particular pass-by% for this case.

932 - High-Turnover (Sit-Down) Restaurant (General Urban/Suburban)
ITE does not recommend a particular pass-by% for this case.

822 - Strip Retail Plaza (<40k) - 2 (General Urban/Suburban)
ITE does not recommend a particular pass-by% for this case.

SUMMARY

Total Entering	385
Total Exiting	384
Total Entering Reduction	0
Total Exiting Reduction	0
Total Entering Internal Capture Reduction	0
Total Exiting Internal Capture Reduction	0
Total Entering Pass-by Reduction	252
Total Exiting Pass-by Reduction	245
Total Entering Non-Pass-by Trips	133
Total Exiting Non-Pass-by Trips	139

APPENDIX
PASSERBY CAPTURE RATES

Vehicle Pass-By Rates by Land Use

Source: ITE Trip Generation Manual, 11th Edition

Land Use Code	945									
Land Use	Convenience Store/Gas Station									
Setting	General Urban/Suburban									
Time Period	Weekday AM Peak Period									
# Data Sites	16 Sites with between 2 and 8 VFP					28 Sites with between 9 and 20 VFP				
Average Pass-By Rate	60% for Sites with between 2 and 8 VFP					76% for Sites with between 9 and 20 VFP				
Pass-By Characteristics for Individual Sites										
GFA (000)	VFP	State or Province	Survey Year	# Interviews	Pass-By Trip (%)	Non-Pass-By Trips			Adj Street Peak Hour Volume	Source
						Primary (%)	Diverted (%)	Total (%)		
2	8	Maryland	1992	46	87	13	0	13	2235	25
2.1	6	Maryland	1992	26	58	23	19	42	2080	25
2.1	6	Maryland	1992	26	58	23	19	42	2080	25
2.2	8	Maryland	1992	31	47	34	19	53	1785	25
2.2	< 8	Indiana	1993	79	56	6	38	44	635	2
2.2	8	Maryland	1992	35	78	9	13	22	7080	25
2.3	6	Maryland	1992	37	32	41	27	68	2080	25
2.3	< 8	Kentucky	1993	58	64	5	31	36	1255	2
2.3	6	Maryland	1992	37	32	41	27	68	2080	25
2.4	< 8	Kentucky	1993	—	48	17	35	52	1210	2
2.6	< 8	Kentucky	1993	—	72	15	13	28	940	2
2.8	< 8	Kentucky	1993	—	54	11	35	46	1240	2
3	< 8	Indiana	1993	62	74	10	16	26	790	2
3.6	< 8	Kentucky	1993	49	67	4	29	33	1985	2
3.7	< 8	Kentucky	1993	49	66	16	18	34	990	2
4.694	12	Maryland	2000	—	72	—	—	28	2440	30
4.694	12	Maryland	2000	—	78	—	—	22	1561	30
4.694	12	Maryland	2000	—	79	—	—	21	2764	30
4.848	12	Virginia	2000	—	55	—	—	45	1398	30
5.06	12	Pennsylvania	2000	—	84	—	—	16	3219	30
5.242	12	Virginia	2000	—	74	—	—	26	1160	30
5.242	12	Virginia	2000	—	71	—	—	29	548	30
5.488	12	Delaware	2000	—	80	—	—	20	—	30
5.5	12	Pennsylvania	2000	—	85	—	—	15	2975	30
4.2	< 8	Kentucky	1993	47	62	19	19	38	1705	2
4.694	16	Maryland	2000	—	90	—	—	10	2278	30
4.694	16	Delaware	2000	—	74	—	—	26	2185	30
4.694	16	Delaware	2000	—	58	—	—	42	962	30
4.694	16	Delaware	2000	—	84	—	—	16	2956	30
4.694	16	New Jersey	2000	—	79	—	—	21	1859	30
4.694	20	Delaware	2000	—	84	—	—	16	3864	30
4.848	16	Virginia	2000	—	68	—	—	32	2106	30
4.848	16	Virginia	2000	—	85	—	—	15	2676	30
4.848	16	Virginia	2000	—	75	—	—	25	3244	30
4.848	16	Virginia	2000	—	71	—	—	29	1663	30
4.993	16	Pennsylvania	2000	—	75	—	—	25	1991	30
5.094	16	New Jersey	2000	—	86	—	—	14	1260	30
5.5	16	Pennsylvania	2000	—	82	—	—	18	1570	30
5.543	16	Pennsylvania	2000	—	84	—	—	16	1933	30
5.565	16	Pennsylvania	2000	—	77	—	—	23	2262	30
5.565	16	Pennsylvania	2000	—	68	—	—	32	2854	30
5.565	16	New Jersey	2000	—	58	—	—	42	1253	30
5.565	16	New Jersey	2000	—	79	—	—	21	1928	30
5.565	16	New Jersey	2000	---	84	---	---	16	1953	30

Vehicle Pass-By Rates by Land Use

Source: ITE Trip Generation Manual, 11th Edition

Land Use Code	945									
Land Use	Convenience Store/Gas Station									
Setting	General Urban/Suburban									
Time Period	Weekday PM Peak Period									
# Data Sites	12 Sites with between 2 and 8 VFP					28 Sites with between 9 and 20 VFP				
Average Pass-By Rate	56% for Sites with between 2 and 8 VFP					75% for Sites with between 9 and 20 VFP				
Pass-By Characteristics for Individual Sites										
GFA (000)	VFP	State or Province	Survey Year	# Interviews	Pass-By Trip (%)	Non-Pass-By Trips			Adj Street Peak Hour Volume	Source
						Primary (%)	Diverted (%)	Total (%)		
2.1	8	Maryland	1992	31	52	13	35	48	1785	25
2.1	6	Maryland	1992	30	53	20	27	47	1060	25
2.2	< 8	Indiana	1993	115	48	16	36	52	820	2
2.3	< 8	Kentucky	1993	67	57	16	27	43	1954	2
2.3	6	Maryland	1992	55	40	11	49	60	2760	25
2.4	< 8	Kentucky	1993	—	58	13	29	42	2655	2
2.6	< 8	Kentucky	1993	68	67	15	18	33	950	2
2.8	< 8	Kentucky	1993	—	62	11	27	38	2875	2
3	< 8	Indiana	1993	80	65	15	20	35	1165	2
3.6	< 8	Kentucky	1993	60	56	17	27	44	2505	2
3.7	< 8	Kentucky	1993	70	61	16	23	39	2175	2
4.2	< 8	Kentucky	1993	61	58	26	16	42	2300	2
4.694	12	Maryland	2000	—	78	—	—	22	3549	30
4.694	12	Maryland	2000	—	67	—	—	33	2272	30
4.694	12	Maryland	2000	—	66	—	—	34	3514	30
4.848	12	Virginia	2000	—	71	—	—	29	2350	30
5.06	12	Pennsylvania	2000	—	91	—	—	9	4181	30
5.242	12	Virginia	2000	—	70	—	—	30	2445	30
5.242	12	Virginia	2000	—	56	—	—	44	950	30
5.488	12	Delaware	2000	—	73	—	—	27	—	30
5.5	12	Pennsylvania	2000	—	84	—	—	16	4025	30
4.694	16	Maryland	2000	—	89	—	—	11	2755	30
4.694	16	Delaware	2000	—	73	—	—	27	1858	30
4.694	16	Delaware	2000	—	59	—	—	41	1344	30
4.694	16	Delaware	2000	—	72	—	—	28	3434	30
4.694	16	New Jersey	2000	—	81	—	—	19	1734	30
4.694	20	Delaware	2000	—	76	—	—	24	1616	30
4.848	16	Virginia	2000	—	67	—	—	33	2.954	30
4.848	16	Virginia	2000	—	78	—	—	22	3086	30
4.848	16	Virginia	2000	—	83	—	—	17	4143	30
4.848	16	Virginia	2000	—	73	—	—	27	2534	30
4.993	16	Pennsylvania	2000	—	72	—	—	28	2917	30
5.094	16	New Jersey	2000	—	86	—	—	14	1730	30
5.5	16	Pennsylvania	2000	—	90	—	—	10	2616	30
5.543	16	Pennsylvania	2000	—	87	—	—	13	2363	30
5.565	16	Pennsylvania	2000	—	81	—	—	19	2770	30
5.565	16	Pennsylvania	2000	—	76	—	—	24	3362	30
5.565	16	New Jersey	2000	—	61	—	—	39	1713	30
5.565	16	New Jersey	2000	—	86	—	—	14	1721	30
5.565	16	New Jersey	2000	---	81	---	---	19	2227	30

APPENDIX
TURNING MOVEMENT COUNTS

LOCATION: Lexington Dr & SR 43
 CITY/STATE: Parrish, FL

PROJECT ID: 21-120144-001
 DATE: Thu, Apr 22, 2021

Peak-Hour: 08:00 AM - 09:00 AM
 Peak 15-Minute: 08:45 AM - 09:00 AM

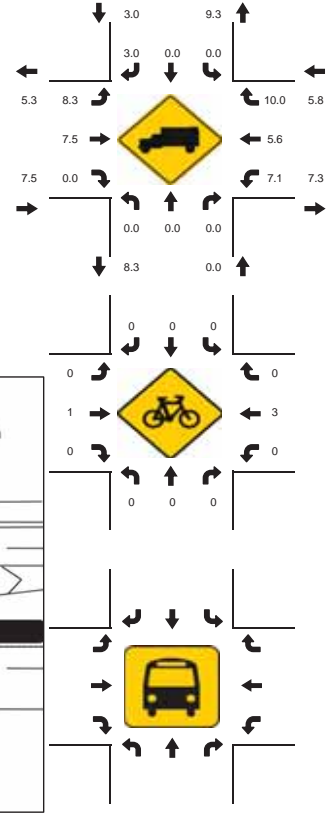
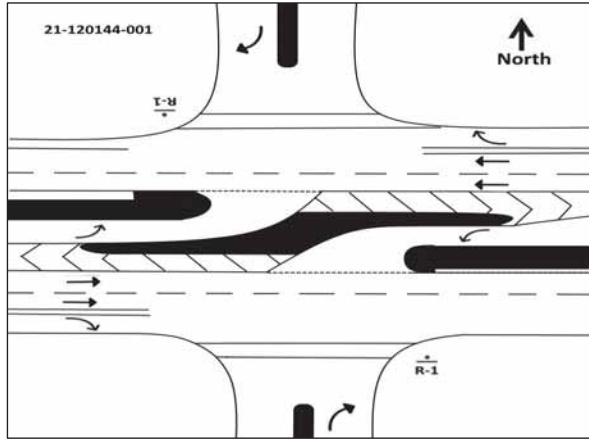
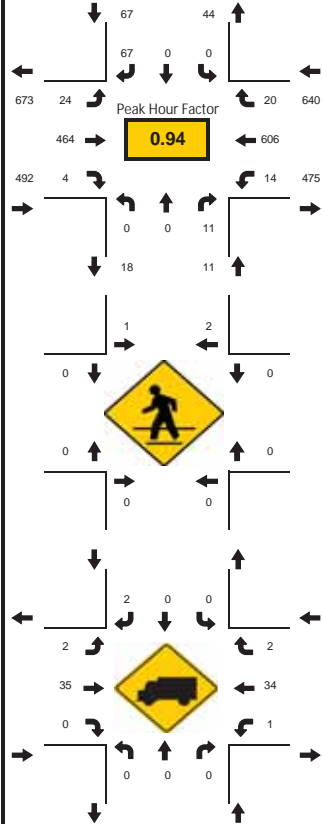

15-Min Count Period Beginning At	Lexington Dr Northbound					Lexington Dr Southbound					SR 43 Eastbound					SR 43 Westbound					Total	Hourly Total
	Left	Thru	Rgt	U	R*	Left	Thru	Rgt	U	R*	Left	Thru	Rgt	U	R*	Left	Thru	Rgt	U	R*		
07:00 AM	0	0	1	0		0	0	23	0		3	99	3	0		2	130	3	0		264	1148
07:15 AM	0	0	2	0		0	0	26	0		5	102	3	0		2	144	1	0		285	1170
07:30 AM	0	0	0	0		0	0	26	0		4	103	1	0		1	153	5	0		293	1176
07:45 AM	0	0	3	0		0	0	18	0		5	133	1	0		1	142	3	0		306	1194
08:00 AM	0	0	3	0		0	0	17	0		2	112	3	0		4	142	2	1		286	1210
08:15 AM	0	0	3	0		0	0	15	0		4	124	0	1		1	135	7	1		291	924
08:30 AM	0	0	3	0		0	0	15	0		9	110	1	0		2	164	5	2		311	633
08:45 AM	0	0	2	0		0	0	20	0		8	118	0	0		1	165	6	2		322	322
Peak 15-Min Flowrates	Northbound					Southbound					Eastbound					Westbound					Total	
All Vehicles	0	0	12	0		0	0	80	0		36	496	12	4		16	660	28	8		1352	
Heavy Trucks	0	0	0	0		0	0	4	0		4	52	0	0		4	44	4	0		112	
Pedestrians	0	0	0	0		0	0	8	0		0	0	0	0		0	0	0	0		8	
Bicycles	0	0	0	0		0	0	0	0		0	4	0	0		0	8	0	0		12	
Buses																						
Stopped Buses																						

LOCATION: Lexington Dr & SR 43
 CITY/STATE: Parrish, FL

PROJECT ID: 21-120144-001
 DATE: Thu, Apr 22, 2021

Peak-Hour: 05:00 PM - 06:00 PM
 Peak 15-Minute: 05:15 PM - 05:30 PM

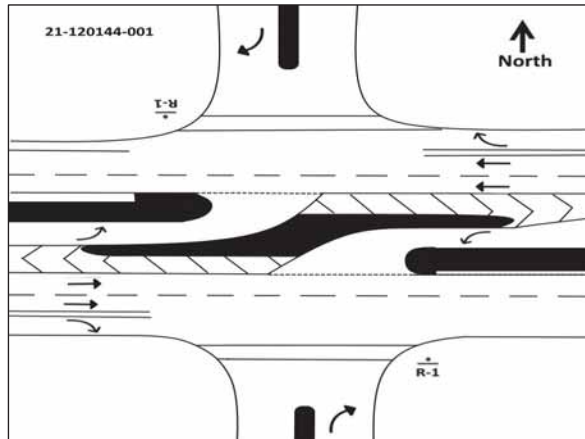
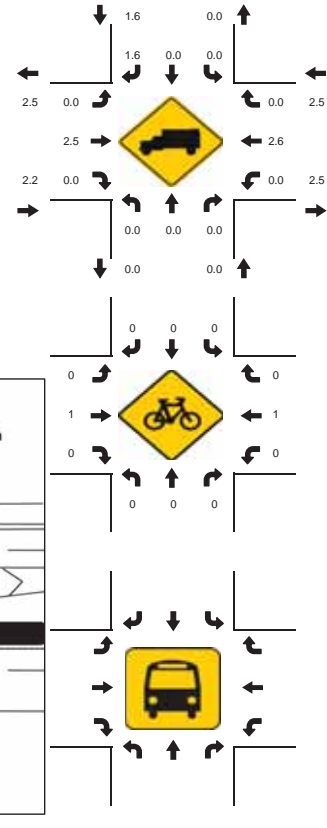
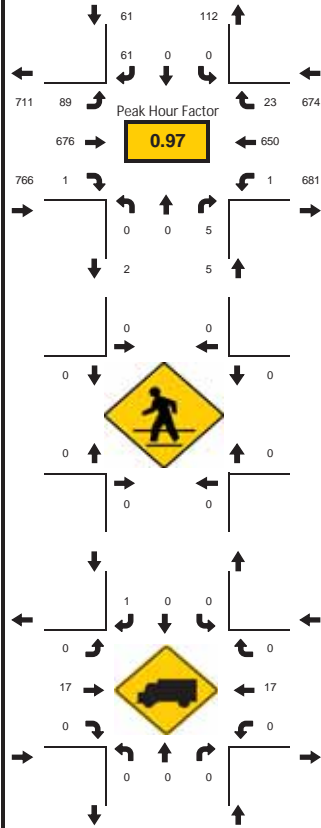

15-Min Count Period Beginning At	Lexington Dr Northbound					Lexington Dr Southbound					SR 43 Eastbound					SR 43 Westbound					Total	Hourly Total
	Left	Thru	Rgt	U	R*	Left	Thru	Rgt	U	R*	Left	Thru	Rgt	U	R*	Left	Thru	Rgt	U	R*		
04:00 PM	0	0	2	0	0	0	0	10	0	0	22	154	1	1	0	0	164	4	0	0	358	1430
04:15 PM	0	0	1	0	0	0	0	14	0	0	22	151	1	0	0	0	157	5	0	0	351	1434
04:30 PM	0	0	3	0	0	0	0	20	0	0	25	159	0	0	0	0	150	6	0	0	363	1471
04:45 PM	0	0	0	0	0	0	0	15	0	0	10	149	0	0	0	0	172	12	0	0	358	1481
05:00 PM	0	0	0	0	0	0	0	9	0	0	16	184	0	0	0	0	147	6	0	0	362	1506
05:15 PM	0	0	2	0	0	0	0	15	0	0	29	186	0	0	0	0	154	2	0	0	388	1144
05:30 PM	0	0	2	0	0	0	0	20	0	0	19	155	1	2	0	0	162	11	1	0	373	756
05:45 PM	0	0	1	0	0	0	0	17	0	0	23	151	0	0	0	0	187	4	0	0	383	383
Peak 15-Min Flowrates	Northbound					Southbound					Eastbound					Westbound					Total	
All Vehicles	0	0	8	0	0	0	0	80	0	0	116	744	4	8	0	0	748	44	4	0	1756	
Heavy Trucks	0	0	0	0	0	0	0	4	0	0	0	20	0	0	0	0	24	0	0	0	48	
Pedestrians	0	0	0	0	0	0	0	0	0	0	0	0	0	0	0	0	0	0	0	0	0	
Bicycles	0	0	0	0	0	0	0	0	0	0	0	4	0	0	0	0	4	0	0	0	8	
Buses																						
Stopped Buses																						

LOCATION: Oxford Rd & SR 43
 CITY/STATE: Parrish, FL

PROJECT ID: 21-120144-002
 DATE: Thu, Apr 22, 2021

Peak-Hour: 08:00 AM - 09:00 AM
 Peak 15-Minute: 08:45 AM - 09:00 AM

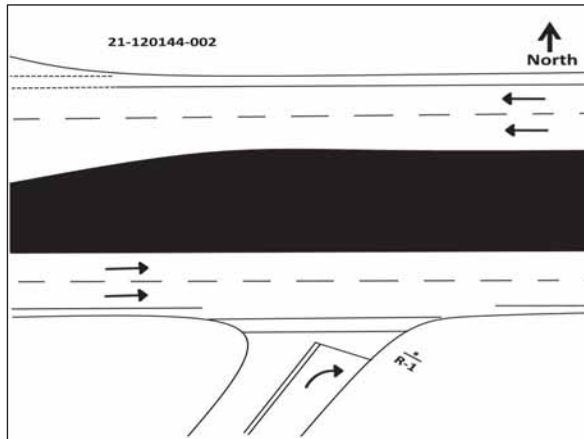
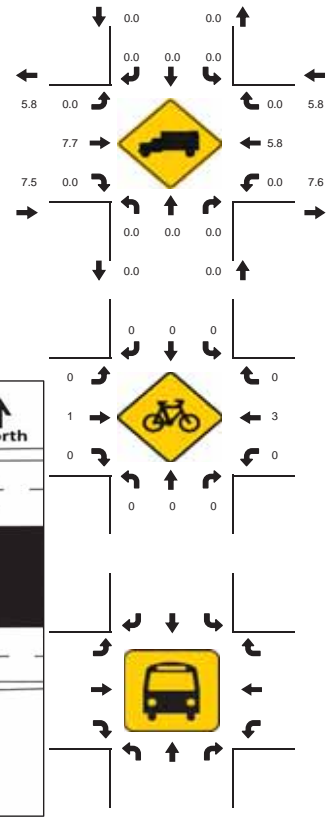
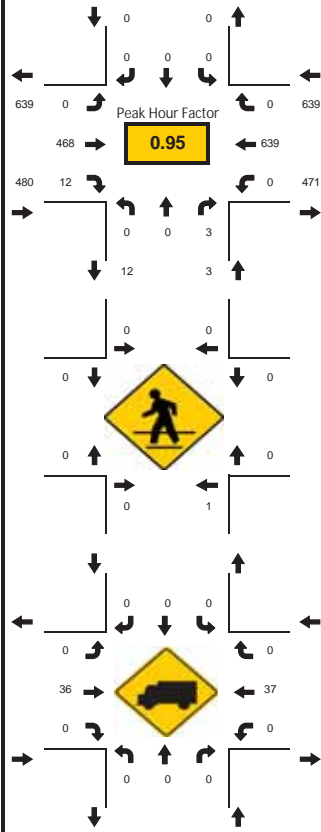

15-Min Count Period Beginning At	Oxford Rd Northbound					Oxford Rd Southbound					SR 43 Eastbound					SR 43 Westbound					Total	Hourly Total
	Left	Thru	Rgt	U	R*	Left	Thru	Rgt	U	R*	Left	Thru	Rgt	U	R*	Left	Thru	Rgt	U	R*		
07:00 AM	0	0	1	0	0	0	0	0	0	0	0	96	1	0	0	0	134	0	0	0	232	1029
07:15 AM	0	0	0	0	0	0	0	0	0	0	0	99	1	0	0	0	152	0	0	0	252	1061
07:30 AM	0	0	0	0	0	0	0	0	0	0	0	104	1	0	0	0	152	0	0	0	257	1079
07:45 AM	0	0	1	0	0	0	0	0	0	0	0	134	6	0	0	0	147	0	0	0	288	1114
08:00 AM	0	0	0	0	0	0	0	0	0	0	0	113	5	0	0	0	146	0	0	0	264	1122
08:15 AM	0	0	1	0	0	0	0	0	0	0	0	114	6	0	0	0	149	0	0	0	270	858
08:30 AM	0	0	2	0	0	0	0	0	0	0	0	123	0	0	0	0	167	0	0	0	292	588
08:45 AM	0	0	0	0	0	0	0	0	0	0	0	118	1	0	0	0	177	0	0	0	296	296
Peak 15-Min Flowrates	Northbound					Southbound					Eastbound					Westbound					Total	
All Vehicles	0	0	8	0	0	0	0	0	0	0	0	492	24	0	0	0	708	0	0	0	1232	
Heavy Trucks	0	0	0	0	0	0	0	0	0	0	0	56	0	0	0	0	40	0	0	0	96	
Pedestrians		4						0				0					0				4	
Bicycles	0	0	0	0	0	0	0	0	0	0	0	4	0	0	0	0	8	0	0	0	12	
Buses																						
Stopped Buses																						

LOCATION: Oxford Rd & SR 43
 CITY/STATE: Parrish, FL

PROJECT ID: 21-120144-002
 DATE: Thu, Apr 22, 2021

Peak-Hour: 05:00 PM - 06:00 PM
 Peak 15-Minute: 05:00 PM - 05:15 PM

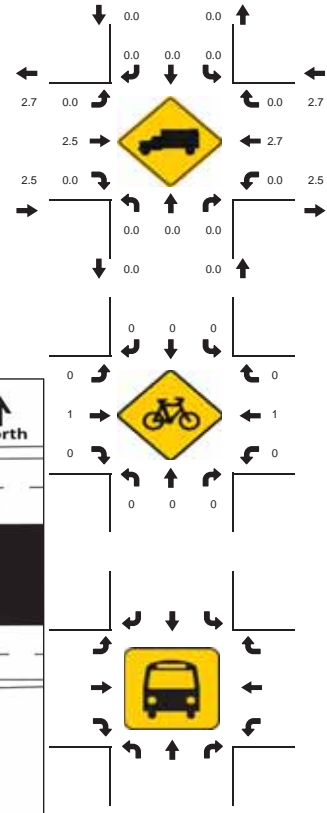
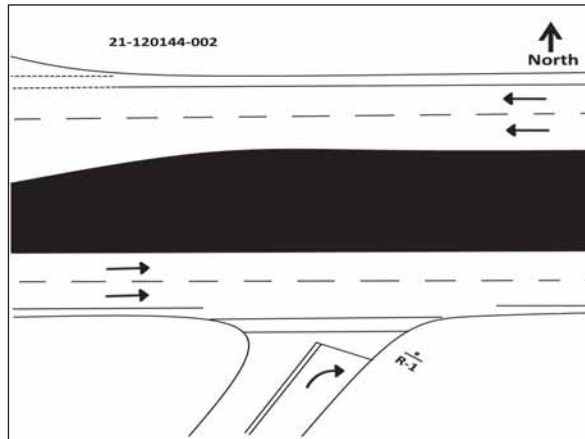
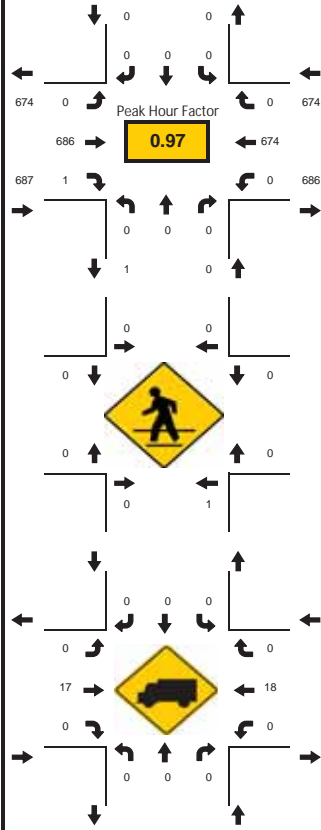

15-Min Count Period Beginning At	Oxford Rd Northbound					Oxford Rd Southbound					SR 43 Eastbound					SR 43 Westbound					Total	Hourly Total
	Left	Thru	Rgt	U	R*	Left	Thru	Rgt	U	R*	Left	Thru	Rgt	U	R*	Left	Thru	Rgt	U	R*		
04:00 PM	0	0	3	0	0	0	0	0	0	0	0	152	1	0	0	0	171	0	0	0	327	1290
04:15 PM	0	0	2	0	0	0	0	0	0	0	0	158	0	0	0	0	156	0	0	0	316	1313
04:30 PM	0	0	0	0	0	0	0	0	0	0	0	159	1	0	0	0	165	0	0	0	325	1344
04:45 PM	0	0	1	0	0	0	0	0	0	0	0	146	0	0	0	0	175	0	0	0	322	1348
05:00 PM	0	0	0	0	0	0	0	0	0	0	0	192	0	0	0	0	158	0	0	0	350	1361
05:15 PM	0	0	0	0	0	0	0	0	0	0	0	185	0	0	0	0	162	0	0	0	347	1011
05:30 PM	0	0	0	0	0	0	0	0	0	0	0	158	0	0	0	0	171	0	0	0	329	664
05:45 PM	0	0	0	0	0	0	0	0	0	0	0	151	1	0	0	0	183	0	0	0	335	335
Peak 15-Min Flowrates	Northbound					Southbound					Eastbound					Westbound					Total	
All Vehicles	0	0	0	0	0	0	0	0	0	0	0	768	4	0	0	0	732	0	0	0	1504	
Heavy Trucks	0	0	0	0	0	0	0	0	0	0	0	20	0	0	0	0	28	0	0	0	48	
Pedestrians		4					0					0					0				4	
Bicycles	0	0	0	0	0	0	0	0	0	0	0	4	0	0	0	0	4	0	0	0	8	
Buses																						
Stopped Buses																						

Peak-Hour: 08:00 AM - 09:00 AM
 Peak 15-Minute: 08:45 AM - 09:00 AM

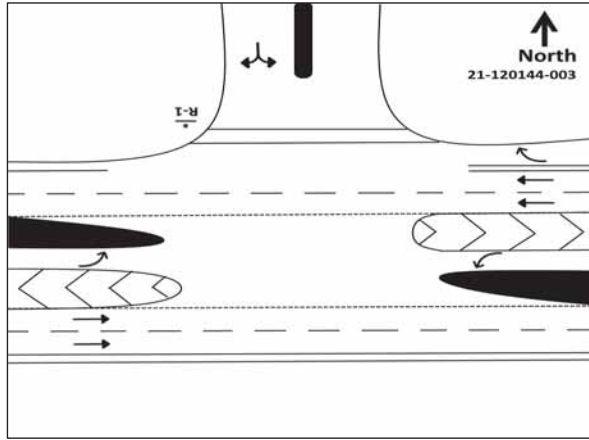
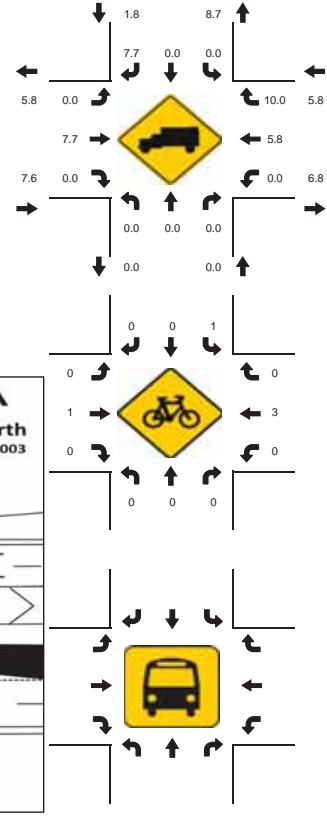
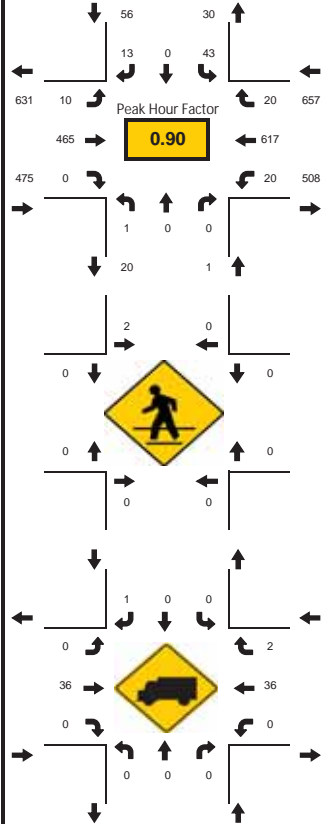

15-Min Count Period Beginning At	116th Ave E Northbound					116th Ave E Southbound					SR 43 Eastbound					SR 43 Westbound					Total	Hourly Total
	Left	Thru	Rgt	U	R*	Left	Thru	Rgt	U	R*	Left	Thru	Rgt	U	R*	Left	Thru	Rgt	U	R*		
07:00 AM	0	0	0	0	0	21	0	4	0	0	1	95	0	0	0	0	136	1	3	0	261	1079
07:15 AM	0	0	0	0	0	7	0	5	0	0	0	96	0	2	0	0	142	6	0	0	258	1098
07:30 AM	0	0	1	0	0	6	0	4	0	0	0	108	0	0	0	0	150	2	2	0	273	1125
07:45 AM	0	0	0	0	0	11	0	4	0	0	1	129	0	0	0	0	136	4	2	0	287	1146
08:00 AM	1	0	0	0	0	17	0	5	0	0	0	114	0	2	0	0	140	1	0	0	280	1189
08:15 AM	0	0	0	0	0	6	0	1	0	0	2	113	0	1	0	0	153	8	1	0	285	909
08:30 AM	0	0	0	0	0	9	0	4	0	0	0	112	0	2	0	0	160	6	1	0	294	624
08:45 AM	0	0	0	0	0	11	0	3	0	0	1	126	0	2	0	0	164	5	18	0	330	330
Peak 15-Min Flowrates	Northbound					Southbound					Eastbound					Westbound					Total	
	Left	Thru	Rgt	U	R*	Left	Thru	Rgt	U	R*	Left	Thru	Rgt	U	R*	Left	Thru	Rgt	U	R*		
All Vehicles	4	0	0	0	0	68	0	20	0	0	8	504	0	8	0	0	656	32	72	0	1372	
Heavy Trucks	0	0	0	0	0	0	0	4	0	0	0	52	0	0	0	0	40	4	0	0	100	
Pedestrians	0	0	0	0	0	0	0	8	0	0	0	0	0	0	0	0	0	0	0	0	8	
Bicycles	0	0	0	0	0	4	0	0	0	0	0	4	0	0	0	0	8	0	0	0	16	
Buses																						
Stopped Buses																						

Peak-Hour: 05:00 PM - 06:00 PM
Peak 15-Minute: 05:15 PM - 05:30 PM

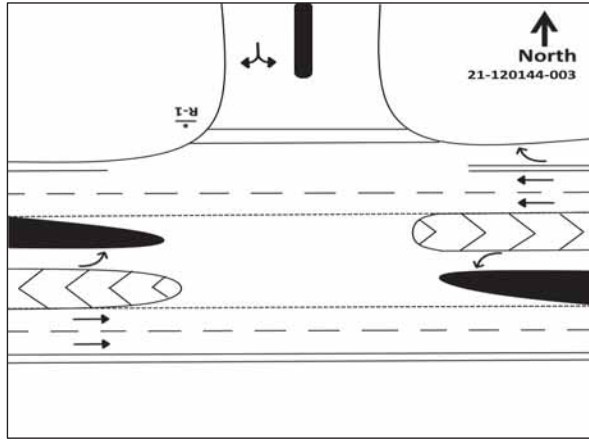
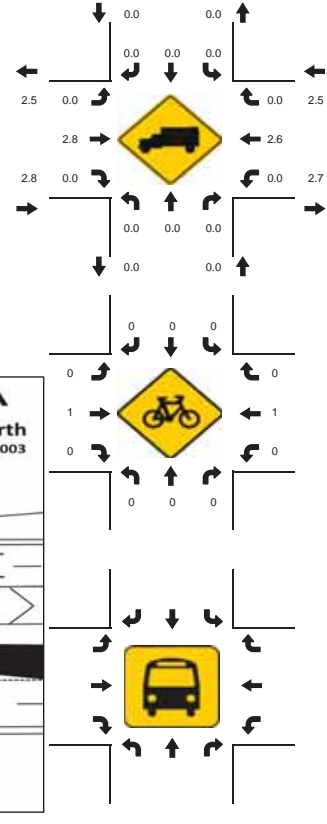
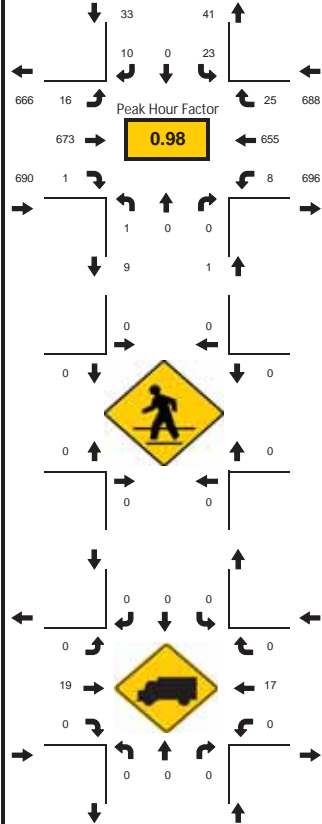

15-Min Count Period Beginning At	116th Ave E Northbound					116th Ave E Southbound					SR 43 Eastbound					SR 43 Westbound					Total	Hourly Total
	Left	Thru	Rgt	U	R*	Left	Thru	Rgt	U	R*	Left	Thru	Rgt	U	R*	Left	Thru	Rgt	U	R*		
04:00 PM	0	0	0	0	0	4	0	3	0	0	4	153	0	2	0	0	168	4	0	0	338	1332
04:15 PM	0	0	0	0	0	2	0	2	0	0	0	151	0	3	0	0	153	7	2	0	320	1351
04:30 PM	0	0	0	0	0	5	0	3	0	0	1	155	0	2	0	0	154	9	4	0	333	1390
04:45 PM	0	0	0	0	0	7	0	1	0	0	0	149	0	0	0	0	182	1	1	0	341	1406
05:00 PM	0	0	0	0	0	9	0	1	0	0	1	187	0	1	0	0	151	6	1	0	357	1412
05:15 PM	0	0	0	0	0	6	0	1	0	0	3	187	0	2	0	0	154	6	0	0	359	1055
05:30 PM	1	0	0	0	0	6	0	3	0	0	5	151	0	1	0	0	170	7	5	0	349	696
05:45 PM	0	0	0	0	0	2	0	5	0	0	3	148	1	0	0	0	180	6	2	0	347	347
Peak 15-Min Flowrates	Northbound					Southbound					Eastbound					Westbound					Total	
All Vehicles	4	0	0	0	0	36	0	20	0	0	20	748	4	8	0	0	720	28	20	0	1608	
Heavy Trucks	0	0	0	0	0	0	0	0	0	0	0	28	0	0	0	0	24	0	0	0	52	
Pedestrians	0	0	0	0	0	0	0	0	0	0	0	0	0	0	0	0	0	0	0	0	0	
Bicycles	0	0	0	0	0	0	0	0	0	0	0	4	0	0	0	0	4	0	0	0	8	
Buses																						
Stopped Buses																						

APPENDIX
FDOT PEAK SEASON ADJUSTMENT FACTORS

2019 PEAK SEASON FACTOR CATEGORY REPORT - REPORT TYPE: ALL
 CATEGORY: 1300 MANATEE COUNTYWIDE

WEEK	DATES	SF	MOCF: 0.93 PSCF
1	01/01/2019 - 01/05/2019	0.99	1.06
2	01/06/2019 - 01/12/2019	0.99	1.06
3	01/13/2019 - 01/19/2019	0.99	1.06
4	01/20/2019 - 01/26/2019	0.97	1.04
5	01/27/2019 - 02/02/2019	0.96	1.03
* 6	02/03/2019 - 02/09/2019	0.94	1.01
* 7	02/10/2019 - 02/16/2019	0.93	1.00
* 8	02/17/2019 - 02/23/2019	0.92	0.99
* 9	02/24/2019 - 03/02/2019	0.92	0.99
*10	03/03/2019 - 03/09/2019	0.91	0.98
*11	03/10/2019 - 03/16/2019	0.90	0.97
*12	03/17/2019 - 03/23/2019	0.91	0.98
*13	03/24/2019 - 03/30/2019	0.92	0.99
*14	03/31/2019 - 04/06/2019	0.92	0.99
*15	04/07/2019 - 04/13/2019	0.93	1.00
*16	04/14/2019 - 04/20/2019	0.93	1.00
*17	04/21/2019 - 04/27/2019	0.95	1.02
*18	04/28/2019 - 05/04/2019	0.96	1.03
19	05/05/2019 - 05/11/2019	0.97	1.04
20	05/12/2019 - 05/18/2019	0.98	1.05
21	05/19/2019 - 05/25/2019	1.00	1.08
22	05/26/2019 - 06/01/2019	1.02	1.10
23	06/02/2019 - 06/08/2019	1.04	1.12
24	06/09/2019 - 06/15/2019	1.06	1.14
25	06/16/2019 - 06/22/2019	1.08	1.16
26	06/23/2019 - 06/29/2019	1.09	1.17
27	06/30/2019 - 07/06/2019	1.11	1.19
28	07/07/2019 - 07/13/2019	1.12	1.20
29	07/14/2019 - 07/20/2019	1.13	1.22
30	07/21/2019 - 07/27/2019	1.12	1.20
31	07/28/2019 - 08/03/2019	1.11	1.19
32	08/04/2019 - 08/10/2019	1.10	1.18
33	08/11/2019 - 08/17/2019	1.09	1.17
34	08/18/2019 - 08/24/2019	1.09	1.17
35	08/25/2019 - 08/31/2019	1.09	1.17
36	09/01/2019 - 09/07/2019	1.08	1.16
37	09/08/2019 - 09/14/2019	1.08	1.16
38	09/15/2019 - 09/21/2019	1.08	1.16
39	09/22/2019 - 09/28/2019	1.06	1.14
40	09/29/2019 - 10/05/2019	1.04	1.12
41	10/06/2019 - 10/12/2019	1.03	1.11
42	10/13/2019 - 10/19/2019	1.01	1.09
43	10/20/2019 - 10/26/2019	1.00	1.08
44	10/27/2019 - 11/02/2019	1.00	1.08
45	11/03/2019 - 11/09/2019	1.00	1.08
46	11/10/2019 - 11/16/2019	0.99	1.06
47	11/17/2019 - 11/23/2019	0.99	1.06
48	11/24/2019 - 11/30/2019	0.99	1.06
49	12/01/2019 - 12/07/2019	0.99	1.06
50	12/08/2019 - 12/14/2019	0.99	1.06
51	12/15/2019 - 12/21/2019	0.99	1.06
52	12/22/2019 - 12/28/2019	0.99	1.06
53	12/29/2019 - 12/31/2019	0.99	1.06

* PEAK SEASON

14-FEB-2020 15:39:19

830UPD

1_1300_PKSEASON.TXT

APPENDIX
FDOT HISTORICAL COUNTS

FLORIDA DEPARTMENT OF TRANSPORTATION
 TRANSPORTATION STATISTICS OFFICE
 2020 HISTORICAL AADT REPORT

COUNTY: 08 - HERNANDO

SITE: 2013 - CR 574/SPRINGHILL DR, EAST OF US 19 (HPMS)

YEAR	AADT	DIRECTION 1		DIRECTION 2		*K FACTOR	D FACTOR	T FACTOR
2020	18400 C	E	8900	W	9500	9.00	54.30	3.50
2019	22500 X		0		0	9.00	54.30	5.50
2018	22000 X		0		0	9.00	54.40	6.40
2017	21500 X		0		0	9.00	55.60	6.70
2016	20500 E		0		0	9.00	54.80	4.70
2015	19600 E					9.00	55.00	3.80
2014	19500 S	E	9700	W	9800	9.00	56.00	3.00
2013	19700 F	E	9800	W	9900	9.00	56.80	3.00
2012	19900 C	E	9900	W	10000	9.00	55.00	3.00
2011	24000 S	E	11000	W	13000	9.00	55.00	1.80
2010	24000 F	E	11000	W	13000	9.74	54.68	1.80
2009	24000 C	E	11000	W	13000	9.60	55.47	1.80
2008	18200 C	E	8200	W	10000	9.72	54.99	4.80

AADT FLAGS: C = COMPUTED; E = MANUAL ESTIMATE; F = FIRST YEAR ESTIMATE
 S = SECOND YEAR ESTIMATE; T = THIRD YEAR ESTIMATE; R = FOURTH YEAR ESTIMATE
 V = FIFTH YEAR ESTIMATE; 6 = SIXTH YEAR ESTIMATE; X = UNKNOWN
 *K FACTOR: STARTING WITH YEAR 2011 IS STANDARDK, PRIOR YEARS ARE K30 VALUES

FLORIDA DEPARTMENT OF TRANSPORTATION
 TRANSPORTATION STATISTICS OFFICE
 2020 HISTORICAL AADT REPORT

COUNTY: 08 - HERNANDO

SITE: 0036 - SR 55/US 19, N OF SPRING HILL DRIVE

YEAR	AADT	DIRECTION 1	DIRECTION 2	*K FACTOR	D FACTOR	T FACTOR
2020	45500 C	N 23000	S 22500	9.00	54.30	4.10
2019	43000 C	N 22000	S 21000	9.00	54.30	3.50
2018	43000 C	N 22000	S 21000	9.00	54.40	3.40
2017	46000 F	N 23000	S 23000	9.00	55.60	3.90
2016	43000 C	N 21500	S 21500	9.00	54.80	3.90
2015	41000 C	N 20500	S 20500	9.00	55.00	3.90
2014	39500 C	N 20000	S 19500	9.00	56.00	3.70
2013	39500 C	N 20000	S 19500	9.00	57.90	3.80
2012	40500 F	N 21000	S 19500	9.00	55.00	3.50
2011	40500 C	N 21000	S 19500	9.00	55.00	3.50
2010	39000 C	N 20000	S 19000	9.74	54.68	3.30
2009	39000 C	N 20000	S 19000	9.60	55.47	3.30
2008	35000 C	N 17500	S 17500	9.72	54.99	3.90
2007	36000 C	N 17500	S 18500	9.34	56.51	4.50
2006	43500 C	N 22000	S 21500	9.54	55.83	5.40
2005	41500 C	N 21000	S 20500	9.60	54.50	5.80

AADT FLAGS: C = COMPUTED; E = MANUAL ESTIMATE; F = FIRST YEAR ESTIMATE
 S = SECOND YEAR ESTIMATE; T = THIRD YEAR ESTIMATE; R = FOURTH YEAR ESTIMATE
 V = FIFTH YEAR ESTIMATE; 6 = SIXTH YEAR ESTIMATE; X = UNKNOWN
 *K FACTOR: STARTING WITH YEAR 2011 IS STANDARDK, PRIOR YEARS ARE K30 VALUES

APPENDIX

FDOT GENERALIZED LEVEL OF SERVICE HANDBOOK TABLES

TABLE 4

Generalized **Peak Hour Two-Way** Volumes for Florida's Urbanized Areas¹

January 2020

INTERRUPTED FLOW FACILITIES						UNINTERRUPTED FLOW FACILITIES					
STATE SIGNALIZED ARTERIALS						FREEWAYS					
Class I (40 mph or higher posted speed limit)						Core Urbanized					
Lanes	Median	B	C	D	E	Lanes	B	C	D	E	
2	Undivided	*	1,510	1,600	**	4	4,050	5,640	6,800	7,420	
4	Divided	*	3,420	3,580	**	6	5,960	8,310	10,220	11,150	
6	Divided	*	5,250	5,390	**	8	7,840	10,960	13,620	14,850	
8	Divided	*	7,090	7,210	**	10	9,800	13,510	17,040	18,580	
						12	11,600	16,350	20,930	23,200	
Class II (35 mph or slower posted speed limit)						Urbanized					
Lanes	Median	B	C	D	E	Lanes	B	C	D	E	
2	Undivided	*	660	1,330	1,410	4	4,130	5,640	7,070	7,690	
4	Divided	*	1,310	2,920	3,040	6	6,200	8,450	10,510	11,530	
6	Divided	*	2,090	4,500	4,590	8	8,270	11,270	13,960	15,380	
8	Divided	*	2,880	6,060	6,130	10	10,350	14,110	17,310	19,220	
Non-State Signalized Roadway Adjustments (Alter corresponding state volumes by the indicated percent.)						Freeway Adjustments					
Non-State Signalized Roadways - 10%						Auxiliary Lanes Present in Both Directions + 1,800					
						Ramp Metering + 5%					
Median & Turn Lane Adjustments						UNINTERRUPTED FLOW HIGHWAYS					
Lanes	Median	Exclusive Left Lanes	Exclusive Right Lanes	Adjustment Factors		Lanes	Median	B	C	D	E
2	Divided	Yes	No	+5%		2	Undivided	1,050	1,620	2,180	2,930
2	Undivided	No	No	-20%		4	Divided	3,270	4,730	5,960	6,780
Multi	Undivided	Yes	No	-5%		6	Divided	4,910	7,090	8,950	10,180
Multi	Undivided	No	No	-25%		Uninterrupted Flow Highway Adjustments					
-	-	-	Yes	+5%		Lanes	Median	Exclusive left lanes	Adjustment factors		
One-Way Facility Adjustment Multiply the corresponding two-directional volumes in this table by 0.6						2	Divided	Yes	+5%		
						Multi	Undivided	Yes	-5%		
						Multi	Undivided	No	-25%		
BICYCLE MODE² (Multiply vehicle volumes shown below by number of directional roadway lanes to determine two-way maximum service volumes.)						¹ Values shown are presented as peak hour directional volumes for levels of service and are for the automobile/truck modes unless specifically stated. This table does not constitute a standard and should be used only for general planning applications. The computer models from which this table is derived should be used for more specific planning applications. The table and deriving computer models should not be used for corridor or intersection design, where more refined techniques exist. Calculations are based on planning applications of the HCM and the Transit Capacity and Quality of Service Manual.					
Paved Shoulder/Bicycle Lane Coverage						² Level of service for the bicycle and pedestrian modes in this table is based on number of vehicles, not number of bicyclists or pedestrians using the facility.					
		B	C	D	E	³ Buses per hour shown are only for the peak hour in the single direction of the higher traffic flow.					
0-49%	*	260	680	1,770		* Cannot be achieved using table input value defaults.					
50-84%	190	600	1,770	>1,770		** Not applicable for that level of service letter grade. For the automobile mode, volumes greater than level of service D become F because intersection capacities have been reached. For the bicycle mode, the level of service letter grade (including F) is not achievable because there is no maximum vehicle volume threshold using table input value defaults.					
85-100%	830	1,700	>1,770	**		<i>Source:</i> Florida Department of Transportation Systems Implementation Office https://www.fdot.gov/planning/systems/					
PEDESTRIAN MODE² (Multiply vehicle volumes shown below by number of directional roadway lanes to determine two-way maximum service volumes.)											
Sidewalk Coverage											
	B	C	D	E							
0-49%	*	*	250	850							
50-84%	*	150	780	1,420							
85-100%	340	960	1,560	>1,770							
BUS MODE (Scheduled Fixed Route)³ (Buses in peak hour in peak direction)											
Sidewalk Coverage											
	B	C	D	E							
0-84%	> 5	≥ 4	≥ 3	≥ 2							
85-100%	> 4	≥ 3	≥ 2	≥ 1							

TABLE 4
(continued)

Generalized **Peak Hour Two-Way** Volumes for Florida's
Urbanized Areas

January 2020

INPUT VALUE ASSUMPTIONS	Uninterrupted Flow Facilities				Interrupted Flow Facilities					
					State Arterials			Class I		
	Freeways	Core Freeways	Highways		Class I	Class II	Bicycle		Pedestrian	
ROADWAY CHARACTERISTICS										
Area type (urban, rural)	urban	urban								
Number of through lanes (both dir.)	4-10	4-12	2	4-6	2	4-8	2	4-8	4	4
Posted speed (mph)	70	65	50	50	45	50	30	30	45	45
Free flow speed (mph)	75	70	55	55	50	55	35	35	50	50
Auxiliary Lanes (n,y)	n	n								
Median (d, twlt, n, nr, r)				d	n	r	n	r	r	r
Terrain (l,r)	l	l	l	l	l	l	l	l	l	l
% no passing zone			80							
Exclusive left turn lane impact (n, y)			[n]	y	y	y	y	y	y	y
Exclusive right turn lanes (n, y)					n	n	n	n	n	n
Facility length (mi)	3	3	5	5	2	2	1.9	1.8	2	2
TRAFFIC CHARACTERISTICS										
Planning analysis hour factor (K)	0.090	0.085	0.090	0.090	0.090	0.090	0.090	0.090	0.090	0.090
Directional distribution factor (D)	0.55	0.55	0.55	0.55	0.550	0.560	0.565	0.560	0.565	0.565
Peak hour factor (PHF)	0.95	0.95	0.95	0.95	1.000	1.000	1.000	1.000	1.000	1.000
Base saturation flow rate (pcphpl)	2,400	2,400	1,700	2,200	1,950	1,950	1,950	1,950	1,950	1,950
Heavy vehicle percent	4.0	4.0	2.0	2.0	1.0	1.0	1.0	1.0	2.5	2.0
Speed Adjustment Factor (SAF)	0.975	0.975		0.975						
Capacity Adjustment Factor (CAF)	0.968	0.968		0.968						
% left turns					12	12	12	12	12	12
% right turns					12	12	12	12	12	12
CONTROL CHARACTERISTICS										
Number of signals					4	4	10	10	4	6
Arrival type (1-6)					3	3	4	4	4	4
Signal type (a, c, p)					c	c	c	c	c	c
Cycle length (C)					120	150	120	120	120	120
Effective green ratio (g/C)					0.44	0.45	0.44	0.44	0.44	0.44
MULTIMODAL CHARACTERISTICS										
Paved shoulder/bicycle lane (n, y)									n, 50%, y	n
Outside lane width (n, t, w)									t	t
Pavement condition (d, t, u)									t	
On-street parking (n, y)										
Sidewalk (n, y)										n, 50%, y
Sidewalk/roadway separation(a, t, w)										t
Sidewalk protective barrier (n, y)										n
LEVEL OF SERVICE THRESHOLDS										
Level of Service	Freeways	Highways		Arterials		Bicycle	Ped	Bus		
	Density	Two-Lane	Multilane	Class I	Class II	Score	Score	Buses/hr.		
		%ffs	Density	ats	ats					
B	≤ 17	> 83.3	≤ 17	> 31 mph	> 22 mph	≤ 2.75	≤ 2.75	≤ 6		
C	≤ 24	> 75.0	≤ 24	> 23 mph	> 17 mph	≤ 3.50	≤ 3.50	≤ 4		
D	≤ 31	> 66.7	≤ 31	> 18 mph	> 13 mph	≤ 4.25	≤ 4.25	< 3		
E	≤ 39	> 58.3	≤ 35	> 15 mph	> 10 mph	≤ 5.00	≤ 5.00	< 2		

% ffs = Percent free flow speed ats = Average travel speed

APPENDIX
SIGNAL TIMINGS

Hernando County, FL

2 - Commercial Wy @ Spring Hill Dr - 192.168.150.79 - Econolite Type - ASC3

Controller Timing Plan (MM)2-1

Plan 1

Phase	1	2	3	4	5	6	7	8	9	10	11	12	13	14	15	16
Direction	NBLT	SB	EBLT	WB	SBLT	NB	WBLT	EB								
Min Green	5	20	5	10	5	20	5	10	0	0	0	0	0	0	0	0
BK Min Green	0	0	0	0	0	0	0	0	0	0	0	0	0	0	0	0
CS Min Green	0	0	0	0	0	0	0	0	0	0	0	0	0	0	0	0
Delay Green	0	0	0	0	0	0	0	0	0	0	0	0	0	0	0	0
Walk	0	7	0	0	0	0	0	7	0	0	0	0	0	0	0	0
Walk 2	0	0	0	0	0	0	0	0	0	0	0	0	0	0	0	0
Walk Max	0	0	0	0	0	0	0	0	0	0	0	0	0	0	0	0
Ped Clear	0	50	0	0	0	0	0	35	0	0	0	0	0	0	0	0
Ped Clear 2	0	0	0	0	0	0	0	0	0	0	0	0	0	0	0	0
Ped Clear Max	0	0	0	0	0	0	0	0	0	0	0	0	0	0	0	0
Ped CO	0	0	0	0	0	0	0	0	0	0	0	0	0	0	0	0
Vehicle Ext	3.0	4.0	4.0	3.0	3.5	4.0	4.0	3.0	0.0	0.0	0.0	0.0	0.0	0.0	0.0	0.0
Vehicle Ext 2	0.0	0.0	0.0	0.0	0.0	0.0	0.0	0.0	0.0	0.0	0.0	0.0	0.0	0.0	0.0	0.0
Max 1	35	60	15	35	35	35	15	35	0	0	0	0	0	0	0	0
Max 2	15	50	15	20	15	50	15	20	0	0	0	0	0	0	0	0
Max 3	0	0	0	0	0	0	0	0	0	0	0	0	0	0	0	0
DYM Max	0	0	0	0	0	0	0	0	0	0	0	0	0	0	0	0
DYM Stp	0.0	0.0	0.0	0.0	0.0	0.0	0.0	0.0	0.0	0.0	0.0	0.0	0.0	0.0	0.0	0.0
Yellow	5.6	5.6	4.5	4.5	5.6	5.6	4.5	4.5	3.0	3.0	3.0	3.0	3.0	3.0	3.0	3.0
Red Clear	2.6	2.6	3.5	3.5	2.6	2.6	3.5	3.5	2.0	2.0	2.0	2.0	2.0	2.0	2.0	2.0
Red Max	0.0	0.0	0.0	0.0	0.0	0.0	0.0	0.0	0.0	0.0	0.0	0.0	0.0	0.0	0.0	0.0
Red Revert	2.0	2.0	2.0	2.0	2.0	2.0	2.0	2.0	2.0	2.0	2.0	2.0	2.0	2.0	2.0	2.0
ACT B4	0	0	0	0	0	0	0	0	0	0	0	0	0	0	0	0
SEC/ACT	0.0	0.0	0.0	0.0	0.0	0.0	0.0	0.0	0.0	0.0	0.0	0.0	0.0	0.0	0.0	0.0
Max Int	30	30	30	30	30	30	30	30	30	30	30	30	0	0	0	0
Time B4	0	0	0	0	0	0	0	0	0	0	0	0	0	0	0	0
Cars Wt	0	0	0	0	0	0	0	0	0	0	0	0	0	0	0	0
STPT Duc	0.0	0.0	0.0	0.0	0.0	0.0	0.0	0.0	0.0	0.0	0.0	0.0	0.0	0.0	0.0	0.0
Time To Reduce	0	0	0	0	0	0	0	0	0	0	0	0	0	0	0	0
Min Gap	0.0	0.0	0.0	0.0	0.0	0.0	0.0	0.0	0.0	0.0	0.0	0.0	0.0	0.0	0.0	0.0

APPENDIX
INTERSECTION ANALYSIS

Timings

1: US 19 & Spring Hill Dr

08/10/2022



Lane Group	EBL	EBT	EBR	WBL	WBT	WBR	NBL	NBT	NBR	SBL	SBT	SBR
Lane Configurations												
Traffic Volume (vph)	172	118	110	424	148	218	66	928	200	283	1060	46
Future Volume (vph)	172	118	110	424	148	218	66	928	200	283	1060	46
Confl. Peds. (#/hr)												
Confl. Bikes (#/hr)												
Peak Hour Factor	0.95	0.95	0.95	0.95	0.95	0.95	0.95	0.95	0.95	0.95	0.95	0.95
Growth Factor	100%	100%	100%	100%	100%	100%	100%	100%	100%	100%	100%	100%
Heavy Vehicles (%)	2%	2%	2%	2%	2%	2%	2%	2%	2%	2%	2%	2%
Bus Blockages (#/hr)	0	0	0	0	0	0	0	0	0	0	0	0
Parking (#/hr)												
Mid-Block Traffic (%)		0%			0%			0%			0%	
Shared Lane Traffic (%)												
Turn Type	Prot	NA	Perm	Prot	NA	Perm	Prot	NA	Perm	Prot	NA	Perm
Protected Phases	3	8		7	4		1	6		5	2	
Permitted Phases			8			4			6			2
Detector Phase	3	8	8	7	4	4	1	6	6	5	2	2
Switch Phase												
Minimum Initial (s)	5.0	10.0	10.0	5.0	10.0	10.0	5.0	20.0	20.0	5.0	20.0	20.0
Minimum Split (s)	14.0	18.0	18.0	14.0	18.0	18.0	14.0	28.2	28.2	14.0	28.2	28.2
Total Split (s)	25.0	25.0	25.0	30.0	30.0	30.0	20.0	55.0	55.0	30.0	65.0	65.0
Total Split (%)	17.9%	17.9%	17.9%	21.4%	21.4%	21.4%	14.3%	39.3%	39.3%	21.4%	46.4%	46.4%
Yellow Time (s)	4.5	4.5	4.5	4.5	4.5	4.5	5.6	5.6	5.6	5.6	5.6	5.6
All-Red Time (s)	3.5	3.5	3.5	3.5	3.5	3.5	2.6	2.6	2.6	2.6	2.6	2.6
Lost Time Adjust (s)	0.0	0.0	0.0	0.0	0.0	0.0	0.0	0.0	0.0	0.0	0.0	0.0
Total Lost Time (s)	8.0	8.0	8.0	8.0	8.0	8.0	8.2	8.2	8.2	8.2	8.2	8.2
Lead/Lag	Lead	Lag	Lag	Lead	Lag	Lag	Lead	Lag	Lag	Lead	Lag	Lag
Lead-Lag Optimize?	Yes	Yes	Yes	Yes	Yes	Yes	Yes	Yes	Yes	Yes	Yes	Yes
Recall Mode	None	None	None	None	None	None	None	C-Max	C-Max	None	C-Max	C-Max
Act Effct Green (s)	12.7	11.8	11.8	21.2	20.2	20.2	10.2	57.3	57.3	17.4	67.5	67.5
Actuated g/C Ratio	0.09	0.08	0.08	0.15	0.14	0.14	0.07	0.41	0.41	0.12	0.48	0.48
v/c Ratio	0.58	0.42	0.34	0.86	0.58	0.54	0.54	0.47	0.27	0.70	0.46	0.06
Control Delay	68.5	64.7	2.6	74.8	65.1	11.0	77.6	32.2	3.7	67.6	26.3	0.1
Queue Delay	0.0	0.0	0.0	0.0	0.0	0.0	0.0	0.0	0.0	0.0	0.0	0.0
Total Delay	68.5	64.7	2.6	74.8	65.1	11.0	77.6	32.2	3.7	67.6	26.3	0.1
LOS	E	E	A	E	E	B	E	C	A	E	C	A
Approach Delay		49.2			55.4			29.9			33.9	
Approach LOS		D			E			C			C	

Intersection Summary

Cycle Length: 140
 Actuated Cycle Length: 140
 Offset: 55 (39%), Referenced to phase 2:SBT and 6:NBT, Start of Green
 Natural Cycle: 80
 Control Type: Actuated-Coordinated
 Maximum v/c Ratio: 0.86
 Intersection Signal Delay: 38.8
 Intersection Capacity Utilization 73.4%
 Analysis Period (min) 15
 Intersection LOS: D
 ICU Level of Service D

Timings

1: US 19 & Spring Hill Dr

08/10/2022

Splits and Phases: 1: US 19 & Spring Hill Dr



HCM 6th TWSC
2: US 19 & Osowaw Blvd/Driveway B

08/10/2022

Intersection												
Int Delay, s/veh	1.7											
Movement	EBL	EBT	EBR	WBL	WBT	WBR	NBL	NBT	NBR	SBL	SBT	SBR
Lane Configurations			↗	↘		↗		↑↑↑	↗	↘	↑↑↑	↗
Traffic Vol, veh/h	0	0	8	49	0	40	0	1217	64	46	1336	101
Future Vol, veh/h	0	0	8	49	0	40	0	1217	64	46	1336	101
Conflicting Peds, #/hr	0	0	0	0	0	0	0	0	0	0	0	0
Sign Control	Stop	Stop	Stop	Stop	Stop	Stop	Free	Free	Free	Free	Free	Free
RT Channelized	-	-	Yield	-	-	None	-	-	None	-	-	Free
Storage Length	-	-	0	0	-	0	-	-	405	405	-	550
Veh in Median Storage, #	-	2	-	-	2	-	-	0	-	-	0	-
Grade, %	-	0	-	-	0	-	-	0	-	-	0	-
Peak Hour Factor	95	95	95	95	95	95	95	95	95	95	95	95
Heavy Vehicles, %	2	2	2	2	2	2	2	2	2	2	2	2
Mvmt Flow	0	0	8	52	0	42	0	1281	67	48	1406	106

Major/Minor	Minor2		Minor1		Major1			Major2				
Conflicting Flow All	-	-	703	1939	-	641	-	0	0	1348	0	0
Stage 1	-	-	-	1281	-	-	-	-	-	-	-	-
Stage 2	-	-	-	658	-	-	-	-	-	-	-	-
Critical Hdwy	-	-	7.14	6.44	-	7.14	-	-	-	5.34	-	-
Critical Hdwy Stg 1	-	-	-	7.34	-	-	-	-	-	-	-	-
Critical Hdwy Stg 2	-	-	-	6.74	-	-	-	-	-	-	-	-
Follow-up Hdwy	-	-	3.92	3.82	-	3.92	-	-	-	3.12	-	-
Pot Cap-1 Maneuver	0	0	326	69	0	358	0	-	-	265	-	0
Stage 1	0	0	-	127	0	-	0	-	-	-	-	0
Stage 2	0	0	-	382	0	-	0	-	-	-	-	0
Platoon blocked, %								-	-	-		
Mov Cap-1 Maneuver	-	-	326	58	-	358	-	-	-	265	-	-
Mov Cap-2 Maneuver	-	-	-	117	-	-	-	-	-	-	-	-
Stage 1	-	-	-	127	-	-	-	-	-	-	-	-
Stage 2	-	-	-	305	-	-	-	-	-	-	-	-

Approach	EB		WB		NB		SB	
HCM Control Delay, s	16.3		39.4		0		0.7	
HCM LOS	C		E					

Minor Lane/Major Mvmt	NBT	NBR	EBLn1WBLn1WBLn2	SBL	SBT
Capacity (veh/h)	-	-	326 117 358	265	-
HCM Lane V/C Ratio	-	-	0.026 0.441 0.118	0.183	-
HCM Control Delay (s)	-	-	16.3 58.1 16.4	21.6	-
HCM Lane LOS	-	-	C F C	C	-
HCM 95th %tile Q(veh)	-	-	0.1 1.9 0.4	0.7	-

HCM 6th TWSC
3: Pinehurst Dr & Spring Hill Dr

08/10/2022

Intersection												
Int Delay, s/veh	5.6											
Movement	EBL	EBT	EBR	WBL	WBT	WBR	NBL	NBT	NBR	SBL	SBT	SBR
Lane Configurations		↑↑		↑	↑↑				↑		↑↓	
Traffic Vol, veh/h	0	442	75	82	675	110	0	0	64	87	8	164
Future Vol, veh/h	0	442	75	82	675	110	0	0	64	87	8	164
Conflicting Peds, #/hr	0	0	0	0	0	0	0	0	0	0	0	0
Sign Control	Free	Free	Free	Free	Free	Free	Stop	Stop	Stop	Stop	Stop	Stop
RT Channelized	-	-	None	-	-	None	-	-	None	-	-	None
Storage Length	-	-	-	150	-	-	-	-	0	-	-	-
Veh in Median Storage, #	-	0	-	-	0	-	-	0	-	-	2	-
Grade, %	-	0	-	-	0	-	-	0	-	-	0	-
Peak Hour Factor	95	95	95	95	95	95	95	95	95	95	95	95
Heavy Vehicles, %	2	2	2	2	2	2	2	2	2	2	2	2
Mvmt Flow	0	465	79	86	711	116	0	0	67	92	8	173

Major/Minor	Major1			Major2			Minor1			Minor2		
Conflicting Flow All	-	0	0	544	0	0	-	-	272	1174	1485	414
Stage 1	-	-	-	-	-	-	-	-	-	941	941	-
Stage 2	-	-	-	-	-	-	-	-	-	233	544	-
Critical Hdwy	-	-	-	4.14	-	-	-	-	6.94	7.54	6.54	6.94
Critical Hdwy Stg 1	-	-	-	-	-	-	-	-	-	6.54	5.54	-
Critical Hdwy Stg 2	-	-	-	-	-	-	-	-	-	6.54	5.54	-
Follow-up Hdwy	-	-	-	2.22	-	-	-	-	3.32	3.52	4.02	3.32
Pot Cap-1 Maneuver	0	-	-	1021	-	-	0	0	726	147	124	587
Stage 1	0	-	-	-	-	-	0	0	-	283	340	-
Stage 2	0	-	-	-	-	-	0	0	-	749	517	-
Platoon blocked, %	-	-	-	-	-	-	-	-	-	-	-	-
Mov Cap-1 Maneuver	-	-	-	1021	-	-	-	-	726	125	114	587
Mov Cap-2 Maneuver	-	-	-	-	-	-	-	-	-	257	259	-
Stage 1	-	-	-	-	-	-	-	-	-	283	311	-
Stage 2	-	-	-	-	-	-	-	-	-	679	517	-

Approach	EB			WB			NB			SB		
HCM Control Delay, s	0			0.8			10.5			31.4		
HCM LOS							B			D		

Minor Lane/Major Mvmt	NBLn1	EBT	EBR	WBL	WBT	WBR	SBLn1
Capacity (veh/h)	726	-	-	1021	-	-	399
HCM Lane V/C Ratio	0.093	-	-	0.085	-	-	0.683
HCM Control Delay (s)	10.5	-	-	8.9	-	-	31.4
HCM Lane LOS	B	-	-	A	-	-	D
HCM 95th %tile Q(veh)	0.3	-	-	0.3	-	-	4.9

Timings

1: US 19 & Spring Hill Dr

08/11/2022



Lane Group	EBL	EBT	EBR	WBL	WBT	WBR	NBL	NBT	NBR	SBL	SBT	SBR
Lane Configurations												
Traffic Volume (vph)	212	191	55	342	141	290	83	1373	253	345	949	70
Future Volume (vph)	212	191	55	342	141	290	83	1373	253	345	949	70
Confl. Peds. (#/hr)												
Confl. Bikes (#/hr)												
Peak Hour Factor	0.95	0.95	0.95	0.95	0.95	0.95	0.95	0.95	0.95	0.95	0.95	0.95
Growth Factor	100%	100%	100%	100%	100%	100%	100%	100%	100%	100%	100%	100%
Heavy Vehicles (%)	2%	2%	2%	2%	2%	2%	2%	2%	2%	2%	2%	2%
Bus Blockages (#/hr)	0	0	0	0	0	0	0	0	0	0	0	0
Parking (#/hr)												
Mid-Block Traffic (%)		0%			0%			0%			0%	
Shared Lane Traffic (%)												
Turn Type	Prot	NA	Perm	Prot	NA	Perm	Prot	NA	Perm	Prot	NA	Perm
Protected Phases	3	8		7	4		1	6		5	2	
Permitted Phases			8			4			6			2
Detector Phase	3	8	8	7	4	4	1	6	6	5	2	2
Switch Phase												
Minimum Initial (s)	5.0	10.0	10.0	5.0	10.0	10.0	5.0	20.0	20.0	5.0	20.0	20.0
Minimum Split (s)	14.0	18.0	18.0	14.0	18.0	18.0	14.0	28.2	28.2	14.0	28.2	28.2
Total Split (s)	25.0	25.0	25.0	28.0	28.0	28.0	20.0	59.0	59.0	28.0	67.0	67.0
Total Split (%)	17.9%	17.9%	17.9%	20.0%	20.0%	20.0%	14.3%	42.1%	42.1%	20.0%	47.9%	47.9%
Yellow Time (s)	4.5	4.5	4.5	4.5	4.5	4.5	5.6	5.6	5.6	5.6	5.6	5.6
All-Red Time (s)	3.5	3.5	3.5	3.5	3.5	3.5	2.6	2.6	2.6	2.6	2.6	2.6
Lost Time Adjust (s)	0.0	0.0	0.0	0.0	0.0	0.0	0.0	0.0	0.0	0.0	0.0	0.0
Total Lost Time (s)	8.0	8.0	8.0	8.0	8.0	8.0	8.2	8.2	8.2	8.2	8.2	8.2
Lead/Lag	Lead	Lag	Lag	Lead	Lag	Lag	Lead	Lag	Lag	Lead	Lag	Lag
Lead-Lag Optimize?	Yes	Yes	Yes	Yes	Yes	Yes	Yes	Yes	Yes	Yes	Yes	Yes
Recall Mode	None	None	None	None	None	None	None	C-Max	C-Max	None	C-Max	C-Max
Act Effect Green (s)	14.1	13.8	13.8	18.5	18.2	18.2	10.7	56.8	56.8	18.5	64.6	64.6
Actuated g/C Ratio	0.10	0.10	0.10	0.13	0.13	0.13	0.08	0.41	0.41	0.13	0.46	0.46
v/c Ratio	0.64	0.58	0.19	0.79	0.61	0.83	0.64	0.70	0.33	0.80	0.43	0.09
Control Delay	69.1	66.7	1.4	72.3	68.7	42.6	84.1	37.8	4.5	72.8	26.8	0.2
Queue Delay	0.0	0.0	0.0	0.0	0.0	0.0	0.0	0.0	0.0	0.0	0.0	0.0
Total Delay	69.1	66.7	1.4	72.3	68.7	42.6	84.1	37.8	4.5	72.8	26.8	0.2
LOS	E	E	A	E	E	D	F	D	A	E	C	A
Approach Delay		59.9			60.5			35.1			37.1	
Approach LOS		E			E			D			D	

Intersection Summary

Cycle Length: 140

Actuated Cycle Length: 140

Offset: 59 (42%), Referenced to phase 2:SBT and 6:NBT, Start of Green

Natural Cycle: 90

Control Type: Actuated-Coordinated

Maximum v/c Ratio: 0.83

Intersection Signal Delay: 42.9

Intersection LOS: D

Intersection Capacity Utilization 81.5%

ICU Level of Service D

Analysis Period (min) 15

Timings

1: US 19 & Spring Hill Dr

08/11/2022

Splits and Phases: 1: US 19 & Spring Hill Dr



HCM 6th TWSC
2: US 19 & Osowaw Blvd/Driveway B

08/11/2022

Intersection												
Int Delay, s/veh	4.1											
Movement	EBL	EBT	EBR	WBL	WBT	WBR	NBL	NBT	NBR	SBL	SBT	SBR
Lane Configurations			↗	↘		↗		↑↑↑	↗	↘	↑↑↑	↗
Traffic Vol, veh/h	0	0	12	42	0	44	0	1766	71	36	1326	112
Future Vol, veh/h	0	0	12	42	0	44	0	1766	71	36	1326	112
Conflicting Peds, #/hr	0	0	0	0	0	0	0	0	0	0	0	0
Sign Control	Stop	Stop	Stop	Stop	Stop	Stop	Free	Free	Free	Free	Free	Free
RT Channelized	-	-	Yield	-	-	None	-	-	None	-	-	Free
Storage Length	-	-	0	0	-	0	-	-	405	405	-	550
Veh in Median Storage, #	-	2	-	-	2	-	-	0	-	-	0	-
Grade, %	-	0	-	-	0	-	-	0	-	-	0	-
Peak Hour Factor	95	95	95	95	95	95	95	95	95	95	95	95
Heavy Vehicles, %	2	2	2	2	2	2	2	2	2	2	2	2
Mvmt Flow	0	0	13	44	0	46	0	1859	75	38	1396	118

Major/Minor	Minor2		Minor1		Major1			Major2				
Conflicting Flow All	-	-	698	2493	-	930	-	0	0	1934	0	0
Stage 1	-	-	-	1859	-	-	-	-	-	-	-	-
Stage 2	-	-	-	634	-	-	-	-	-	-	-	-
Critical Hdwy	-	-	7.14	6.44	-	7.14	-	-	-	5.34	-	-
Critical Hdwy Stg 1	-	-	-	7.34	-	-	-	-	-	-	-	-
Critical Hdwy Stg 2	-	-	-	6.74	-	-	-	-	-	-	-	-
Follow-up Hdwy	-	-	3.92	3.82	-	3.92	-	-	-	3.12	-	-
Pot Cap-1 Maneuver	0	0	328	~ 31	0	231	0	-	-	135	-	0
Stage 1	0	0	-	49	0	-	0	-	-	-	-	0
Stage 2	0	0	-	395	0	-	0	-	-	-	-	0
Platoon blocked, %								-	-	-		
Mov Cap-1 Maneuver	-	-	328	~ 23	-	231	-	-	-	135	-	-
Mov Cap-2 Maneuver	-	-	-	46	-	-	-	-	-	-	-	-
Stage 1	-	-	-	49	-	-	-	-	-	-	-	-
Stage 2	-	-	-	273	-	-	-	-	-	-	-	-

Approach	EB		WB		NB		SB	
HCM Control Delay, s	16.4		138.9		0		1.1	
HCM LOS	C		F					

Minor Lane/Major Mvmt	NBT	NBR	EBLn1	WBLn1	WBLn2	SBL	SBT
Capacity (veh/h)	-	-	328	46	231	135	-
HCM Lane V/C Ratio	-	-	0.039	0.961	0.201	0.281	-
HCM Control Delay (s)	-	-	16.4	258.7	24.5	41.8	-
HCM Lane LOS	-	-	C	F	C	E	-
HCM 95th %tile Q(veh)	-	-	0.1	4	0.7	1.1	-

Notes
 -: Volume exceeds capacity \$: Delay exceeds 300s +: Computation Not Defined *: All major volume in platoon

HCM 6th TWSC
3: Pinehurst Dr & Spring Hill Dr

08/11/2022

Intersection												
Int Delay, s/veh	6											
Movement	EBL	EBT	EBR	WBL	WBT	WBR	NBL	NBT	NBR	SBL	SBT	SBR
Lane Configurations		↑↑		↑	↑↑				↑		↑↓	
Traffic Vol, veh/h	0	660	60	67	680	103	0	0	163	104	8	125
Future Vol, veh/h	0	660	60	67	680	103	0	0	163	104	8	125
Conflicting Peds, #/hr	0	0	0	0	0	0	0	0	0	0	0	0
Sign Control	Free	Free	Free	Free	Free	Free	Stop	Stop	Stop	Stop	Stop	Stop
RT Channelized	-	-	None	-	-	None	-	-	None	-	-	None
Storage Length	-	-	-	150	-	-	-	-	0	-	-	-
Veh in Median Storage, #	-	0	-	-	0	-	-	0	-	-	2	-
Grade, %	-	0	-	-	0	-	-	0	-	-	0	-
Peak Hour Factor	95	95	95	95	95	95	95	95	95	95	95	95
Heavy Vehicles, %	2	2	2	2	2	2	2	2	2	2	2	2
Mvmt Flow	0	695	63	71	716	108	0	0	172	109	8	132

Major/Minor	Major1			Major2			Minor1			Minor2		
Conflicting Flow All	-	0	0	758	0	0	-	-	379	1260	1670	412
Stage 1	-	-	-	-	-	-	-	-	-	912	912	-
Stage 2	-	-	-	-	-	-	-	-	-	348	758	-
Critical Hdwy	-	-	-	4.14	-	-	-	-	6.94	7.54	6.54	6.94
Critical Hdwy Stg 1	-	-	-	-	-	-	-	-	-	6.54	5.54	-
Critical Hdwy Stg 2	-	-	-	-	-	-	-	-	-	6.54	5.54	-
Follow-up Hdwy	-	-	-	2.22	-	-	-	-	3.32	3.52	4.02	3.32
Pot Cap-1 Maneuver	0	-	-	849	-	-	0	0	619	127	95	589
Stage 1	0	-	-	-	-	-	0	0	-	295	351	-
Stage 2	0	-	-	-	-	-	0	0	-	641	413	-
Platoon blocked, %	-	-	-	-	-	-	-	-	-	-	-	-
Mov Cap-1 Maneuver	-	-	-	849	-	-	-	-	619	~ 86	87	589
Mov Cap-2 Maneuver	-	-	-	-	-	-	-	-	-	237	237	-
Stage 1	-	-	-	-	-	-	-	-	-	295	322	-
Stage 2	-	-	-	-	-	-	-	-	-	463	413	-

Approach	EB	WB	NB	SB
HCM Control Delay, s	0	0.8	13	38.2
HCM LOS			B	E

Minor Lane/Major Mvmt	NBLn1	EBT	EBR	WBL	WBT	WBR	SBLn1
Capacity (veh/h)	619	-	-	849	-	-	346
HCM Lane V/C Ratio	0.277	-	-	0.083	-	-	0.721
HCM Control Delay (s)	13	-	-	9.6	-	-	38.2
HCM Lane LOS	B	-	-	A	-	-	E
HCM 95th %tile Q(veh)	1.1	-	-	0.3	-	-	5.4

Notes
 -: Volume exceeds capacity \$: Delay exceeds 300s +: Computation Not Defined *: All major volume in platoon

Timings

1: US 19 & Spring Hill Dr

08/10/2022



Lane Group	EBL	EBT	EBR	WBL	WBT	WBR	NBL	NBT	NBR	SBL	SBT	SBR
Lane Configurations												
Traffic Volume (vph)	172	118	110	307	126	312	66	928	200	377	1177	68
Future Volume (vph)	172	118	110	307	126	312	66	928	200	377	1177	68
Confl. Peds. (#/hr)												
Confl. Bikes (#/hr)												
Peak Hour Factor	0.95	0.95	0.95	0.95	0.95	0.95	0.95	0.95	0.95	0.95	0.95	0.95
Growth Factor	100%	100%	100%	100%	100%	100%	100%	100%	100%	100%	100%	100%
Heavy Vehicles (%)	2%	2%	2%	2%	2%	2%	2%	2%	2%	2%	2%	2%
Bus Blockages (#/hr)	0	0	0	0	0	0	0	0	0	0	0	0
Parking (#/hr)												
Mid-Block Traffic (%)		0%			0%			0%			0%	
Shared Lane Traffic (%)												
Turn Type	Prot	NA	Perm	Prot	NA	Perm	Prot	NA	Perm	Prot	NA	Perm
Protected Phases	3	8		7	4		1	6		5	2	
Permitted Phases			8			4			6			2
Detector Phase	3	8	8	7	4	4	1	6	6	5	2	2
Switch Phase												
Minimum Initial (s)	5.0	10.0	10.0	5.0	10.0	10.0	5.0	20.0	20.0	5.0	20.0	20.0
Minimum Split (s)	14.0	18.0	18.0	14.0	18.0	18.0	14.0	28.2	28.2	14.0	28.2	28.2
Total Split (s)	25.0	25.0	25.0	30.0	30.0	30.0	20.0	55.0	55.0	30.0	65.0	65.0
Total Split (%)	17.9%	17.9%	17.9%	21.4%	21.4%	21.4%	14.3%	39.3%	39.3%	21.4%	46.4%	46.4%
Yellow Time (s)	4.5	4.5	4.5	4.5	4.5	4.5	5.6	5.6	5.6	5.6	5.6	5.6
All-Red Time (s)	3.5	3.5	3.5	3.5	3.5	3.5	2.6	2.6	2.6	2.6	2.6	2.6
Lost Time Adjust (s)	0.0	0.0	0.0	0.0	0.0	0.0	0.0	0.0	0.0	0.0	0.0	0.0
Total Lost Time (s)	8.0	8.0	8.0	8.0	8.0	8.0	8.2	8.2	8.2	8.2	8.2	8.2
Lead/Lag	Lead	Lag	Lag	Lead	Lag	Lag	Lead	Lag	Lag	Lead	Lag	Lag
Lead-Lag Optimize?	Yes	Yes	Yes	Yes	Yes	Yes	Yes	Yes	Yes	Yes	Yes	Yes
Recall Mode	None	None	None	None	None	None	None	C-Max	C-Max	None	C-Max	C-Max
Act Effct Green (s)	12.7	12.3	12.3	18.2	17.8	17.8	10.2	56.7	56.7	20.4	69.9	69.9
Actuated g/C Ratio	0.09	0.09	0.09	0.13	0.13	0.13	0.07	0.40	0.40	0.15	0.50	0.50
v/c Ratio	0.58	0.40	0.33	0.73	0.56	0.80	0.54	0.47	0.27	0.80	0.49	0.08
Control Delay	68.5	63.6	2.5	68.1	66.3	32.2	77.6	32.8	3.8	70.1	26.0	0.2
Queue Delay	0.0	0.0	0.0	0.0	0.0	0.0	0.0	0.0	0.0	0.0	0.0	0.0
Total Delay	68.5	63.6	2.5	68.1	66.3	32.2	77.6	32.8	3.8	70.1	26.0	0.2
LOS	E	E	A	E	E	C	E	C	A	E	C	A
Approach Delay		48.9			52.8			30.4			35.1	
Approach LOS		D			D			C			D	

Intersection Summary

Cycle Length: 140

Actuated Cycle Length: 140

Offset: 55 (39%), Referenced to phase 2:SBT and 6:NBT, Start of Green

Natural Cycle: 80

Control Type: Actuated-Coordinated

Maximum v/c Ratio: 0.80

Intersection Signal Delay: 38.4

Intersection LOS: D

Intersection Capacity Utilization 72.8%

ICU Level of Service C

Analysis Period (min) 15

Timings

1: US 19 & Spring Hill Dr

08/10/2022

Splits and Phases: 1: US 19 & Spring Hill Dr



HCM 6th TWSC
2: US 19 & Osowaw Blvd/Driveway B

08/10/2022

Intersection												
Int Delay, s/veh	72.9											
Movement	EBL	EBT	EBR	WBL	WBT	WBR	NBL	NBT	NBR	SBL	SBT	SBR
Lane Configurations			↗	↘		↗		↑↑↑	↗	↘	↑↑↑	↗
Traffic Vol, veh/h	0	0	8	282	0	40	0	1217	93	46	1336	101
Future Vol, veh/h	0	0	8	282	0	40	0	1217	93	46	1336	101
Conflicting Peds, #/hr	0	0	0	0	0	0	0	0	0	0	0	0
Sign Control	Stop	Stop	Stop	Stop	Stop	Stop	Free	Free	Free	Free	Free	Free
RT Channelized	-	-	Yield	-	-	None	-	-	None	-	-	Free
Storage Length	-	-	0	0	-	0	-	-	405	405	-	550
Veh in Median Storage, #	-	2	-	-	2	-	-	0	-	-	0	-
Grade, %	-	0	-	-	0	-	-	0	-	-	0	-
Peak Hour Factor	95	95	95	95	95	95	95	95	95	95	95	95
Heavy Vehicles, %	2	2	2	2	2	2	2	2	2	2	2	2
Mvmt Flow	0	0	8	297	0	42	0	1281	98	48	1406	106

Major/Minor	Minor2		Minor1		Major1			Major2				
Conflicting Flow All	-	-	703	1939	-	641	-	0	0	1379	0	0
Stage 1	-	-	-	1281	-	-	-	-	-	-	-	-
Stage 2	-	-	-	658	-	-	-	-	-	-	-	-
Critical Hdwy	-	-	7.14	6.44	-	7.14	-	-	-	5.34	-	-
Critical Hdwy Stg 1	-	-	-	7.34	-	-	-	-	-	-	-	-
Critical Hdwy Stg 2	-	-	-	6.74	-	-	-	-	-	-	-	-
Follow-up Hdwy	-	-	3.92	3.82	-	3.92	-	-	-	3.12	-	-
Pot Cap-1 Maneuver	0	0	326	~ 69	0	358	0	-	-	256	-	0
Stage 1	0	0	-	~ 127	0	-	0	-	-	-	-	0
Stage 2	0	0	-	382	0	-	0	-	-	-	-	0
Platoon blocked, %								-	-	-		
Mov Cap-1 Maneuver	-	-	326	~ 58	-	358	-	-	-	256	-	-
Mov Cap-2 Maneuver	-	-	-	~ 117	-	-	-	-	-	-	-	-
Stage 1	-	-	-	~ 127	-	-	-	-	-	-	-	-
Stage 2	-	-	-	302	-	-	-	-	-	-	-	-

Approach	EB	WB	NB	SB
HCM Control Delay, s	16.3	\$ 680.8	0	0.7
HCM LOS	C	F		

Minor Lane/Major Mvmt	NBT	NBR	EBLn1WBLn1WBLn2	SBL	SBT
Capacity (veh/h)	-	-	326 117 358	256	-
HCM Lane V/C Ratio	-	-	0.026 2.537 0.118 0.189	-	-
HCM Control Delay (s)	-	-	16.3 \$ 775 16.4 22.3	-	-
HCM Lane LOS	-	-	C F C C	-	-
HCM 95th %tile Q(veh)	-	-	0.1 26.7 0.4 0.7	-	-

Notes
 -: Volume exceeds capacity \$: Delay exceeds 300s +: Computation Not Defined *: All major volume in platoon

HCM 6th TWSC
3: Pinehurst Dr & Spring Hill Dr

08/10/2022

Intersection												
Int Delay, s/veh	1.3											
Movement	EBL	EBT	EBR	WBL	WBT	WBR	NBL	NBT	NBR	SBL	SBT	SBR
Lane Configurations		↑↓		↑	↑↓				↑		↑↓	
Traffic Vol, veh/h	0	536	75	82	765	27	0	0	64	5	8	25
Future Vol, veh/h	0	536	75	82	765	27	0	0	64	5	8	25
Conflicting Peds, #/hr	0	0	0	0	0	0	0	0	0	0	0	0
Sign Control	Free	Free	Free	Free	Free	Free	Stop	Stop	Stop	Stop	Stop	Stop
RT Channelized	-	-	None	-	-	None	-	-	None	-	-	None
Storage Length	-	-	-	150	-	-	-	-	0	-	-	-
Veh in Median Storage, #	-	0	-	-	0	-	-	0	-	-	2	-
Grade, %	-	0	-	-	0	-	-	0	-	-	0	-
Peak Hour Factor	95	95	95	95	95	95	95	95	95	95	95	95
Heavy Vehicles, %	2	2	2	2	2	2	2	2	2	2	2	2
Mvmt Flow	0	564	79	86	805	28	0	0	67	5	8	26

Major/Minor	Major1			Major2			Minor1			Minor2		
Conflicting Flow All	-	0	0	643	0	0	-	-	322	1273	1634	417
Stage 1	-	-	-	-	-	-	-	-	-	991	991	-
Stage 2	-	-	-	-	-	-	-	-	-	282	643	-
Critical Hdwy	-	-	-	4.14	-	-	-	-	6.94	7.54	6.54	6.94
Critical Hdwy Stg 1	-	-	-	-	-	-	-	-	-	6.54	5.54	-
Critical Hdwy Stg 2	-	-	-	-	-	-	-	-	-	6.54	5.54	-
Follow-up Hdwy	-	-	-	2.22	-	-	-	-	3.32	3.52	4.02	3.32
Pot Cap-1 Maneuver	0	-	-	938	-	-	0	0	674	124	100	585
Stage 1	0	-	-	-	-	-	0	0	-	264	322	-
Stage 2	0	-	-	-	-	-	0	0	-	701	467	-
Platoon blocked, %	-	-	-	-	-	-	-	-	-	-	-	-
Mov Cap-1 Maneuver	-	-	-	938	-	-	-	-	674	104	91	585
Mov Cap-2 Maneuver	-	-	-	-	-	-	-	-	-	237	235	-
Stage 1	-	-	-	-	-	-	-	-	-	264	292	-
Stage 2	-	-	-	-	-	-	-	-	-	631	467	-

Approach	EB			WB			NB			SB		
HCM Control Delay, s	0			0.9			10.9			15.3		
HCM LOS							B			C		

Minor Lane/Major Mvmt	NBLn1	EBT	EBR	WBL	WBT	WBR	SBLn1
Capacity (veh/h)	674	-	-	938	-	-	388
HCM Lane V/C Ratio	0.1	-	-	0.092	-	-	0.103
HCM Control Delay (s)	10.9	-	-	9.2	-	-	15.3
HCM Lane LOS	B	-	-	A	-	-	C
HCM 95th %tile Q(veh)	0.3	-	-	0.3	-	-	0.3

Timings

1: US 19 & Spring Hill Dr

08/10/2022



Lane Group	EBL	EBT	EBR	WBL	WBT	WBR	NBL	NBT	NBR	SBL	SBT	SBR
Lane Configurations												
Traffic Volume (vph)	212	191	55	262	120	369	83	1373	253	445	1029	91
Future Volume (vph)	212	191	55	262	120	369	83	1373	253	445	1029	91
Confl. Peds. (#/hr)												
Confl. Bikes (#/hr)												
Peak Hour Factor	0.95	0.95	0.95	0.95	0.95	0.95	0.95	0.95	0.95	0.95	0.95	0.95
Growth Factor	100%	100%	100%	100%	100%	100%	100%	100%	100%	100%	100%	100%
Heavy Vehicles (%)	2%	2%	2%	2%	2%	2%	2%	2%	2%	2%	2%	2%
Bus Blockages (#/hr)	0	0	0	0	0	0	0	0	0	0	0	0
Parking (#/hr)												
Mid-Block Traffic (%)		0%			0%			0%			0%	
Shared Lane Traffic (%)												
Turn Type	Prot	NA	Perm	Prot	NA	Perm	Prot	NA	Perm	Prot	NA	Perm
Protected Phases	3	8		7	4		1	6		5	2	
Permitted Phases			8			4			6			2
Detector Phase	3	8	8	7	4	4	1	6	6	5	2	2
Switch Phase												
Minimum Initial (s)	5.0	10.0	10.0	5.0	10.0	10.0	5.0	20.0	20.0	5.0	20.0	20.0
Minimum Split (s)	14.0	18.0	18.0	14.0	18.0	18.0	14.0	28.2	28.2	14.0	28.2	28.2
Total Split (s)	25.0	25.0	25.0	28.0	28.0	28.0	20.0	59.0	59.0	28.0	67.0	67.0
Total Split (%)	17.9%	17.9%	17.9%	20.0%	20.0%	20.0%	14.3%	42.1%	42.1%	20.0%	47.9%	47.9%
Yellow Time (s)	4.5	4.5	4.5	4.5	4.5	4.5	5.6	5.6	5.6	5.6	5.6	5.6
All-Red Time (s)	3.5	3.5	3.5	3.5	3.5	3.5	2.6	2.6	2.6	2.6	2.6	2.6
Lost Time Adjust (s)	0.0	0.0	0.0	0.0	0.0	0.0	0.0	0.0	0.0	0.0	0.0	0.0
Total Lost Time (s)	8.0	8.0	8.0	8.0	8.0	8.0	8.2	8.2	8.2	8.2	8.2	8.2
Lead/Lag	Lead	Lag	Lag	Lead	Lag	Lag	Lead	Lag	Lag	Lead	Lag	Lag
Lead-Lag Optimize?	Yes	Yes	Yes	Yes	Yes	Yes	Yes	Yes	Yes	Yes	Yes	Yes
Recall Mode	None	None	None	None	None	None	None	C-Max	C-Max	None	C-Max	C-Max
Act Effect Green (s)	14.1	20.7	20.7	16.3	22.9	22.9	10.6	50.8	50.8	19.8	60.0	60.0
Actuated g/C Ratio	0.10	0.15	0.15	0.12	0.16	0.16	0.08	0.36	0.36	0.14	0.43	0.43
v/c Ratio	0.64	0.39	0.15	0.69	0.41	0.94	0.65	0.78	0.36	0.96	0.50	0.12
Control Delay	69.1	57.2	0.9	68.5	58.2	61.7	84.7	43.4	4.8	92.3	30.2	0.3
Queue Delay	0.0	0.0	0.0	0.0	0.0	0.0	0.0	0.0	0.0	0.0	0.0	0.0
Total Delay	69.1	57.2	0.9	68.5	58.2	61.7	84.7	43.4	4.8	92.3	30.2	0.3
LOS	E	E	A	E	E	E	F	D	A	F	C	A
Approach Delay		55.9			63.5			39.7			46.1	
Approach LOS		E			E			D			D	

Intersection Summary

Cycle Length: 140
 Actuated Cycle Length: 140
 Offset: 59 (42%), Referenced to phase 2:SBT and 6:NBT, Start of Green
 Natural Cycle: 90
 Control Type: Actuated-Coordinated
 Maximum v/c Ratio: 0.96
 Intersection Signal Delay: 47.6
 Intersection Capacity Utilization 82.0%
 Analysis Period (min) 15
 Intersection LOS: D
 ICU Level of Service E

Timings

1: US 19 & Spring Hill Dr

08/10/2022

Splits and Phases: 1: US 19 & Spring Hill Dr



HCM 6th TWSC
2: US 19 & Osowaw Blvd/Driveway B

08/10/2022

Intersection												
Int Delay, s/veh	154.5											
Movement	EBL	EBT	EBR	WBL	WBT	WBR	NBL	NBT	NBR	SBL	SBT	SBR
Lane Configurations			↗	↘		↗		↑↑↑	↗	↘	↑↑↑	↗
Traffic Vol, veh/h	0	0	12	243	0	44	0	1766	93	36	1326	112
Future Vol, veh/h	0	0	12	243	0	44	0	1766	93	36	1326	112
Conflicting Peds, #/hr	0	0	0	0	0	0	0	0	0	0	0	0
Sign Control	Stop	Stop	Stop	Stop	Stop	Stop	Free	Free	Free	Free	Free	Free
RT Channelized	-	-	Yield	-	-	None	-	-	None	-	-	Free
Storage Length	-	-	0	0	-	0	-	-	405	405	-	550
Veh in Median Storage, #	-	2	-	-	2	-	-	0	-	-	0	-
Grade, %	-	0	-	-	0	-	-	0	-	-	0	-
Peak Hour Factor	95	95	95	95	95	95	95	95	95	95	95	95
Heavy Vehicles, %	2	2	2	2	2	2	2	2	2	2	2	2
Mvmt Flow	0	0	13	256	0	46	0	1859	98	38	1396	118

Major/Minor	Minor2		Minor1		Major1			Major2				
Conflicting Flow All	-	-	698	2493	-	930	-	0	0	1957	0	0
Stage 1	-	-	-	1859	-	-	-	-	-	-	-	-
Stage 2	-	-	-	634	-	-	-	-	-	-	-	-
Critical Hdwy	-	-	7.14	6.44	-	7.14	-	-	-	5.34	-	-
Critical Hdwy Stg 1	-	-	-	7.34	-	-	-	-	-	-	-	-
Critical Hdwy Stg 2	-	-	-	6.74	-	-	-	-	-	-	-	-
Follow-up Hdwy	-	-	3.92	3.82	-	3.92	-	-	-	3.12	-	-
Pot Cap-1 Maneuver	0	0	328	~ 31	0	231	0	-	-	131	-	0
Stage 1	0	0	-	~ 49	0	-	0	-	-	-	-	0
Stage 2	0	0	-	395	0	-	0	-	-	-	-	0
Platoon blocked, %								-	-	-		
Mov Cap-1 Maneuver	-	-	328	~ 23	-	231	-	-	-	131	-	-
Mov Cap-2 Maneuver	-	-	-	~ 46	-	-	-	-	-	-	-	-
Stage 1	-	-	-	~ 49	-	-	-	-	-	-	-	-
Stage 2	-	-	-	270	-	-	-	-	-	-	-	-

Approach	EB		WB		NB		SB	
HCM Control Delay, s	16.4		\$ 1889.2		0		1.1	
HCM LOS	C		F					

Minor Lane/Major Mvmt	NBT	NBR	EBLn1	WBLn1	WBLn2	SBL	SBT
Capacity (veh/h)	-	-	328	46	231	131	-
HCM Lane V/C Ratio	-	-	0.039	5.561	0.201	0.289	-
HCM Control Delay (s)	-	-	16.4	2226.9	24.5	43.3	-
HCM Lane LOS	-	-	C	F	C	E	-
HCM 95th %tile Q(veh)	-	-	0.1	29.5	0.7	1.1	-

Notes
 -: Volume exceeds capacity \$: Delay exceeds 300s +: Computation Not Defined *: All major volume in platoon

HCM 6th TWSC
3: Pinehurst Dr & Spring Hill Dr

08/10/2022

Intersection												
Int Delay, s/veh	2											
Movement	EBL	EBT	EBR	WBL	WBT	WBR	NBL	NBT	NBR	SBL	SBT	SBR
Lane Configurations		↑↓		↑	↑↓				↑		↑↓	
Traffic Vol, veh/h	0	760	60	67	757	32	0	0	163	13	8	24
Future Vol, veh/h	0	760	60	67	757	32	0	0	163	13	8	24
Conflicting Peds, #/hr	0	0	0	0	0	0	0	0	0	0	0	0
Sign Control	Free	Free	Free	Free	Free	Free	Stop	Stop	Stop	Stop	Stop	Stop
RT Channelized	-	-	None	-	-	None	-	-	None	-	-	None
Storage Length	-	-	-	150	-	-	-	-	0	-	-	-
Veh in Median Storage, #	-	0	-	-	0	-	-	0	-	-	2	-
Grade, %	-	0	-	-	0	-	-	0	-	-	0	-
Peak Hour Factor	95	95	95	95	95	95	95	95	95	95	95	95
Heavy Vehicles, %	2	2	2	2	2	2	2	2	2	2	2	2
Mvmt Flow	0	800	63	71	797	34	0	0	172	14	8	25

Major/Minor	Major1			Major2			Minor1			Minor2		
Conflicting Flow All	-	0	0	863	0	0	-	-	432	1356	1819	416
Stage 1	-	-	-	-	-	-	-	-	-	956	956	-
Stage 2	-	-	-	-	-	-	-	-	-	400	863	-
Critical Hdwy	-	-	-	4.14	-	-	-	-	6.94	7.54	6.54	6.94
Critical Hdwy Stg 1	-	-	-	-	-	-	-	-	-	6.54	5.54	-
Critical Hdwy Stg 2	-	-	-	-	-	-	-	-	-	6.54	5.54	-
Follow-up Hdwy	-	-	-	2.22	-	-	-	-	3.32	3.52	4.02	3.32
Pot Cap-1 Maneuver	0	-	-	775	-	-	0	0	572	108	77	585
Stage 1	0	-	-	-	-	-	0	0	-	277	335	-
Stage 2	0	-	-	-	-	-	0	0	-	597	370	-
Platoon blocked, %	-	-	-	-	-	-	-	-	-	-	-	-
Mov Cap-1 Maneuver	-	-	-	775	-	-	-	-	572	70	70	585
Mov Cap-2 Maneuver	-	-	-	-	-	-	-	-	-	215	213	-
Stage 1	-	-	-	-	-	-	-	-	-	277	304	-
Stage 2	-	-	-	-	-	-	-	-	-	418	370	-

Approach	EB			WB			NB			SB		
HCM Control Delay, s	0			0.8			14			18		
HCM LOS							B			C		

Minor Lane/Major Mvmt	NBLn1	EBT	EBR	WBL	WBT	WBR	SBLn1
Capacity (veh/h)	572	-	-	775	-	-	324
HCM Lane V/C Ratio	0.3	-	-	0.091	-	-	0.146
HCM Control Delay (s)	14	-	-	10.1	-	-	18
HCM Lane LOS	B	-	-	B	-	-	C
HCM 95th %tile Q(veh)	1.3	-	-	0.3	-	-	0.5

Timings

1: US 19 & Spring Hill Dr

08/10/2022



Lane Group	EBL	EBT	EBR	WBL	WBT	WBR	NBL	NBT	NBR	SBL	SBT	SBR
Lane Configurations	↔↔	↑↑	↗	↔↔	↑	↗	↖	↑↑↑	↗	↔↔	↑↑↑	↗
Traffic Volume (vph)	172	118	110	424	148	301	66	928	200	283	1060	46
Future Volume (vph)	172	118	110	424	148	301	66	928	200	283	1060	46
Confl. Peds. (#/hr)												
Confl. Bikes (#/hr)												
Peak Hour Factor	0.95	0.95	0.95	0.95	0.95	0.95	0.95	0.95	0.95	0.95	0.95	0.95
Growth Factor	100%	100%	100%	100%	100%	100%	100%	100%	100%	100%	100%	100%
Heavy Vehicles (%)	2%	2%	2%	2%	2%	2%	2%	2%	2%	2%	2%	2%
Bus Blockages (#/hr)	0	0	0	0	0	0	0	0	0	0	0	0
Parking (#/hr)												
Mid-Block Traffic (%)		0%			0%			0%			0%	
Shared Lane Traffic (%)												
Turn Type	Prot	NA	Perm	Prot	NA	Perm	Prot	NA	Perm	Prot	NA	Perm
Protected Phases	3	8		7	4		1	6		5	2	
Permitted Phases			8			4			6			2
Detector Phase	3	8	8	7	4	4	1	6	6	5	2	2
Switch Phase												
Minimum Initial (s)	5.0	10.0	10.0	5.0	10.0	10.0	5.0	20.0	20.0	5.0	20.0	20.0
Minimum Split (s)	14.0	18.0	18.0	14.0	18.0	18.0	14.0	28.2	28.2	14.0	28.2	28.2
Total Split (s)	25.0	25.0	25.0	30.0	30.0	30.0	20.0	55.0	55.0	30.0	65.0	65.0
Total Split (%)	17.9%	17.9%	17.9%	21.4%	21.4%	21.4%	14.3%	39.3%	39.3%	21.4%	46.4%	46.4%
Yellow Time (s)	4.5	4.5	4.5	4.5	4.5	4.5	5.6	5.6	5.6	5.6	5.6	5.6
All-Red Time (s)	3.5	3.5	3.5	3.5	3.5	3.5	2.6	2.6	2.6	2.6	2.6	2.6
Lost Time Adjust (s)	0.0	0.0	0.0	0.0	0.0	0.0	0.0	0.0	0.0	0.0	0.0	0.0
Total Lost Time (s)	8.0	8.0	8.0	8.0	8.0	8.0	8.2	8.2	8.2	8.2	8.2	8.2
Lead/Lag	Lead	Lag	Lag	Lead	Lag	Lag	Lead	Lag	Lag	Lead	Lag	Lag
Lead-Lag Optimize?	Yes	Yes	Yes	Yes	Yes	Yes	Yes	Yes	Yes	Yes	Yes	Yes
Recall Mode	None	None	None	None	None	None	None	C-Max	C-Max	None	C-Max	C-Max
Act Effect Green (s)	12.7	11.9	11.9	21.2	20.4	20.4	10.2	57.1	57.1	17.4	67.3	67.3
Actuated g/C Ratio	0.09	0.08	0.08	0.15	0.15	0.15	0.07	0.41	0.41	0.12	0.48	0.48
v/c Ratio	0.58	0.41	0.34	0.86	0.58	0.73	0.54	0.47	0.27	0.70	0.46	0.06
Control Delay	68.5	64.3	2.6	74.8	64.6	25.7	77.6	32.3	3.8	67.6	26.5	0.1
Queue Delay	0.0	0.0	0.0	0.0	0.0	0.0	0.0	0.0	0.0	0.0	0.0	0.0
Total Delay	68.5	64.3	2.6	74.8	64.6	25.7	77.6	32.3	3.8	67.6	26.5	0.1
LOS	E	E	A	E	E	C	E	C	A	E	C	A
Approach Delay		49.1			56.1			30.0			34.0	
Approach LOS		D			E			C			C	

Intersection Summary

Cycle Length: 140
 Actuated Cycle Length: 140
 Offset: 55 (39%), Referenced to phase 2:SBT and 6:NBT, Start of Green
 Natural Cycle: 80
 Control Type: Actuated-Coordinated
 Maximum v/c Ratio: 0.86
 Intersection Signal Delay: 39.4
 Intersection Capacity Utilization 73.4%
 Analysis Period (min) 15
 Intersection LOS: D
 ICU Level of Service D

Timings

1: US 19 & Spring Hill Dr

08/10/2022

Splits and Phases: 1: US 19 & Spring Hill Dr



HCM 6th TWSC
2: US 19 & Osowaw Blvd/Driveway B

08/10/2022

Intersection												
Int Delay, s/veh	1.6											
Movement	EBL	EBT	EBR	WBL	WBT	WBR	NBL	NBT	NBR	SBL	SBT	SBR
Lane Configurations			↗	↘		↗		↑↑↑	↗	↘	↑↑↑	↗
Traffic Vol, veh/h	0	0	8	49	0	40	0	1217	98	46	1336	101
Future Vol, veh/h	0	0	8	49	0	40	0	1217	98	46	1336	101
Conflicting Peds, #/hr	0	0	0	0	0	0	0	0	0	0	0	0
Sign Control	Stop	Stop	Stop	Stop	Stop	Stop	Free	Free	Free	Free	Free	Free
RT Channelized	-	-	Yield	-	-	None	-	-	None	-	-	Free
Storage Length	-	-	0	0	-	0	-	-	405	405	-	550
Veh in Median Storage, #	-	2	-	-	2	-	-	0	-	-	0	-
Grade, %	-	0	-	-	0	-	-	0	-	-	0	-
Peak Hour Factor	95	95	95	95	95	95	95	95	95	95	95	95
Heavy Vehicles, %	2	2	2	2	2	2	2	2	2	2	2	2
Mvmt Flow	0	0	8	52	0	42	0	1281	103	48	1406	106

Major/Minor	Minor2		Minor1		Major1			Major2				
Conflicting Flow All	-	-	703	1939	-	641	-	0	0	1384	0	0
Stage 1	-	-	-	1281	-	-	-	-	-	-	-	-
Stage 2	-	-	-	658	-	-	-	-	-	-	-	-
Critical Hdwy	-	-	7.14	6.44	-	7.14	-	-	-	5.34	-	-
Critical Hdwy Stg 1	-	-	-	7.34	-	-	-	-	-	-	-	-
Critical Hdwy Stg 2	-	-	-	6.74	-	-	-	-	-	-	-	-
Follow-up Hdwy	-	-	3.92	3.82	-	3.92	-	-	-	3.12	-	-
Pot Cap-1 Maneuver	0	0	326	69	0	358	0	-	-	254	-	0
Stage 1	0	0	-	127	0	-	0	-	-	-	-	0
Stage 2	0	0	-	382	0	-	0	-	-	-	-	0
Platoon blocked, %								-	-	-		
Mov Cap-1 Maneuver	-	-	326	57	-	358	-	-	-	254	-	-
Mov Cap-2 Maneuver	-	-	-	117	-	-	-	-	-	-	-	-
Stage 1	-	-	-	127	-	-	-	-	-	-	-	-
Stage 2	-	-	-	302	-	-	-	-	-	-	-	-

Approach	EB		WB		NB			SB		
HCM Control Delay, s	16.3		39.4		0			0.7		
HCM LOS	C		E							

Minor Lane/Major Mvmt	NBT	NBR	EBLn1WBLn1WBLn2	SBL	SBT
Capacity (veh/h)	-	-	326 117 358	254	-
HCM Lane V/C Ratio	-	-	0.026 0.441 0.118	0.191	-
HCM Control Delay (s)	-	-	16.3 58.1 16.4	22.5	-
HCM Lane LOS	-	-	C F C	C	-
HCM 95th %tile Q(veh)	-	-	0.1 1.9 0.4	0.7	-

HCM 6th TWSC
3: Pinehurst Dr & Spring Hill Dr

08/10/2022

Intersection												
Int Delay, s/veh	6.8											
Movement	EBL	EBT	EBR	WBL	WBT	WBR	NBL	NBT	NBR	SBL	SBT	SBR
Lane Configurations		↑↓		↑	↑↓				↑		↑↓	
Traffic Vol, veh/h	0	442	75	82	754	27	0	0	64	99	8	164
Future Vol, veh/h	0	442	75	82	754	27	0	0	64	99	8	164
Conflicting Peds, #/hr	0	0	0	0	0	0	0	0	0	0	0	0
Sign Control	Free	Free	Free	Free	Free	Free	Stop	Stop	Stop	Stop	Stop	Stop
RT Channelized	-	-	None	-	-	None	-	-	None	-	-	None
Storage Length	-	-	-	150	-	-	-	-	0	-	-	-
Veh in Median Storage, #	-	0	-	-	0	-	-	0	-	-	2	-
Grade, %	-	0	-	-	0	-	-	0	-	-	0	-
Peak Hour Factor	95	95	95	95	95	95	95	95	95	95	95	95
Heavy Vehicles, %	2	2	2	2	2	2	2	2	2	2	2	2
Mvmt Flow	0	465	79	86	794	28	0	0	67	104	8	173

Major/Minor	Major1			Major2			Minor1			Minor2		
Conflicting Flow All	-	0	0	544	0	0	-	-	272	1213	1524	411
Stage 1	-	-	-	-	-	-	-	-	-	980	980	-
Stage 2	-	-	-	-	-	-	-	-	-	233	544	-
Critical Hdwy	-	-	-	4.14	-	-	-	-	6.94	7.54	6.54	6.94
Critical Hdwy Stg 1	-	-	-	-	-	-	-	-	-	6.54	5.54	-
Critical Hdwy Stg 2	-	-	-	-	-	-	-	-	-	6.54	5.54	-
Follow-up Hdwy	-	-	-	2.22	-	-	-	-	3.32	3.52	4.02	3.32
Pot Cap-1 Maneuver	0	-	-	1021	-	-	0	0	726	138	117	590
Stage 1	0	-	-	-	-	-	0	0	-	268	326	-
Stage 2	0	-	-	-	-	-	0	0	-	749	517	-
Platoon blocked, %	-	-	-	-	-	-	-	-	-	-	-	-
Mov Cap-1 Maneuver	-	-	-	1021	-	-	-	-	726	117	107	590
Mov Cap-2 Maneuver	-	-	-	-	-	-	-	-	-	244	251	-
Stage 1	-	-	-	-	-	-	-	-	-	268	299	-
Stage 2	-	-	-	-	-	-	-	-	-	679	517	-

Approach	EB			WB			NB			SB		
HCM Control Delay, s	0			0.8			10.5			38.3		
HCM LOS							B			E		

Minor Lane/Major Mvmt	NBLn1	EBT	EBR	WBL	WBT	WBR	SBLn1
Capacity (veh/h)	726	-	-	1021	-	-	379
HCM Lane V/C Ratio	0.093	-	-	0.085	-	-	0.753
HCM Control Delay (s)	10.5	-	-	8.9	-	-	38.3
HCM Lane LOS	B	-	-	A	-	-	E
HCM 95th %tile Q(veh)	0.3	-	-	0.3	-	-	6

Timings

1: US 19 & Spring Hill Dr

08/11/2022



Lane Group	EBL	EBT	EBR	WBL	WBT	WBR	NBL	NBT	NBR	SBL	SBT	SBR
Lane Configurations												
Traffic Volume (vph)	212	191	55	342	141	361	83	1373	253	345	949	70
Future Volume (vph)	212	191	55	342	141	361	83	1373	253	345	949	70
Confl. Peds. (#/hr)												
Confl. Bikes (#/hr)												
Peak Hour Factor	0.95	0.95	0.95	0.95	0.95	0.95	0.95	0.95	0.95	0.95	0.95	0.95
Growth Factor	100%	100%	100%	100%	100%	100%	100%	100%	100%	100%	100%	100%
Heavy Vehicles (%)	2%	2%	2%	2%	2%	2%	2%	2%	2%	2%	2%	2%
Bus Blockages (#/hr)	0	0	0	0	0	0	0	0	0	0	0	0
Parking (#/hr)												
Mid-Block Traffic (%)		0%			0%			0%			0%	
Shared Lane Traffic (%)												
Turn Type	Prot	NA	Perm	Prot	NA	Perm	Prot	NA	Perm	Prot	NA	Perm
Protected Phases	3	8		7	4		1	6		5	2	
Permitted Phases			8			4			6			2
Detector Phase	3	8	8	7	4	4	1	6	6	5	2	2
Switch Phase												
Minimum Initial (s)	5.0	10.0	10.0	5.0	10.0	10.0	5.0	20.0	20.0	5.0	20.0	20.0
Minimum Split (s)	14.0	18.0	18.0	14.0	18.0	18.0	14.0	28.2	28.2	14.0	28.2	28.2
Total Split (s)	25.0	25.0	25.0	28.0	28.0	28.0	20.0	59.0	59.0	28.0	67.0	67.0
Total Split (%)	17.9%	17.9%	17.9%	20.0%	20.0%	20.0%	14.3%	42.1%	42.1%	20.0%	47.9%	47.9%
Yellow Time (s)	4.5	4.5	4.5	4.5	4.5	4.5	5.6	5.6	5.6	5.6	5.6	5.6
All-Red Time (s)	3.5	3.5	3.5	3.5	3.5	3.5	2.6	2.6	2.6	2.6	2.6	2.6
Lost Time Adjust (s)	0.0	0.0	0.0	0.0	0.0	0.0	0.0	0.0	0.0	0.0	0.0	0.0
Total Lost Time (s)	8.0	8.0	8.0	8.0	8.0	8.0	8.2	8.2	8.2	8.2	8.2	8.2
Lead/Lag	Lead	Lag	Lag	Lead	Lag	Lag	Lead	Lag	Lag	Lead	Lag	Lag
Lead-Lag Optimize?	Yes	Yes	Yes	Yes	Yes	Yes	Yes	Yes	Yes	Yes	Yes	Yes
Recall Mode	None	None	None	None	None	None	None	C-Max	C-Max	None	C-Max	C-Max
Act Effect Green (s)	14.1	17.8	17.8	18.5	22.2	22.2	10.6	52.8	52.8	18.5	60.6	60.6
Actuated g/C Ratio	0.10	0.13	0.13	0.13	0.16	0.16	0.08	0.38	0.38	0.13	0.43	0.43
v/c Ratio	0.64	0.45	0.17	0.79	0.50	0.94	0.65	0.75	0.35	0.80	0.45	0.10
Control Delay	69.1	60.3	1.0	72.3	61.0	60.8	84.7	41.4	4.7	73.0	29.2	0.2
Queue Delay	0.0	0.0	0.0	0.0	0.0	0.0	0.0	0.0	0.0	0.0	0.0	0.0
Total Delay	69.1	60.3	1.0	72.3	61.0	60.8	84.7	41.4	4.7	73.0	29.2	0.2
LOS	E	E	A	E	E	E	F	D	A	E	C	A
Approach Delay		57.2			65.5			38.1			38.8	
Approach LOS		E			E			D			D	

Intersection Summary

Cycle Length: 140	
Actuated Cycle Length: 140	
Offset: 59 (42%), Referenced to phase 2:SBT and 6:NBT, Start of Green	
Natural Cycle: 90	
Control Type: Actuated-Coordinated	
Maximum v/c Ratio: 0.94	
Intersection Signal Delay: 45.6	Intersection LOS: D
Intersection Capacity Utilization 81.5%	ICU Level of Service D
Analysis Period (min) 15	

Timings

1: US 19 & Spring Hill Dr

08/11/2022

Splits and Phases: 1: US 19 & Spring Hill Dr



HCM 6th TWSC
2: US 19 & Osowaw Blvd/Driveway B

08/11/2022

Intersection												
Int Delay, s/veh	4.1											
Movement	EBL	EBT	EBR	WBL	WBT	WBR	NBL	NBT	NBR	SBL	SBT	SBR
Lane Configurations			↗	↘		↗		↑↑↑	↗	↘	↑↑↑	↗
Traffic Vol, veh/h	0	0	12	42	0	44	0	1766	101	36	1326	112
Future Vol, veh/h	0	0	12	42	0	44	0	1766	101	36	1326	112
Conflicting Peds, #/hr	0	0	0	0	0	0	0	0	0	0	0	0
Sign Control	Stop	Stop	Stop	Stop	Stop	Stop	Free	Free	Free	Free	Free	Free
RT Channelized	-	-	Yield	-	-	None	-	-	None	-	-	Free
Storage Length	-	-	0	0	-	0	-	-	405	405	-	550
Veh in Median Storage, #	-	2	-	-	2	-	-	0	-	-	0	-
Grade, %	-	0	-	-	0	-	-	0	-	-	0	-
Peak Hour Factor	95	95	95	95	95	95	95	95	95	95	95	95
Heavy Vehicles, %	2	2	2	2	2	2	2	2	2	2	2	2
Mvmt Flow	0	0	13	44	0	46	0	1859	106	38	1396	118

Major/Minor	Minor2		Minor1		Major1			Major2				
Conflicting Flow All	-	-	698	2493	-	930	-	0	0	1965	0	0
Stage 1	-	-	-	1859	-	-	-	-	-	-	-	-
Stage 2	-	-	-	634	-	-	-	-	-	-	-	-
Critical Hdwy	-	-	7.14	6.44	-	7.14	-	-	-	5.34	-	-
Critical Hdwy Stg 1	-	-	-	7.34	-	-	-	-	-	-	-	-
Critical Hdwy Stg 2	-	-	-	6.74	-	-	-	-	-	-	-	-
Follow-up Hdwy	-	-	3.92	3.82	-	3.92	-	-	-	3.12	-	-
Pot Cap-1 Maneuver	0	0	328	~31	0	231	0	-	-	130	-	0
Stage 1	0	0	-	49	0	-	0	-	-	-	-	0
Stage 2	0	0	-	395	0	-	0	-	-	-	-	0
Platoon blocked, %								-	-	-		
Mov Cap-1 Maneuver	-	-	328	~23	-	231	-	-	-	130	-	-
Mov Cap-2 Maneuver	-	-	-	46	-	-	-	-	-	-	-	-
Stage 1	-	-	-	49	-	-	-	-	-	-	-	-
Stage 2	-	-	-	269	-	-	-	-	-	-	-	-

Approach	EB		WB		NB		SB	
HCM Control Delay, s	16.4		138.9		0		1.2	
HCM LOS	C		F					

Minor Lane/Major Mvmt	NBT	NBR	EBLn1	WBLn1	WBLn2	SBL	SBT
Capacity (veh/h)	-	-	328	46	231	130	-
HCM Lane V/C Ratio	-	-	0.039	0.961	0.201	0.291	-
HCM Control Delay (s)	-	-	16.4	258.7	24.5	43.7	-
HCM Lane LOS	-	-	C	F	C	E	-
HCM 95th %tile Q(veh)	-	-	0.1	4	0.7	1.1	-

Notes
 -: Volume exceeds capacity \$: Delay exceeds 300s +: Computation Not Defined *: All major volume in platoon

HCM 6th TWSC
3: Pinehurst Dr & Spring Hill Dr

08/11/2022

Intersection												
Int Delay, s/veh	7.1											
Movement	EBL	EBT	EBR	WBL	WBT	WBR	NBL	NBT	NBR	SBL	SBT	SBR
Lane Configurations		↑↑		↑	↑↑				↑		↑↓	
Traffic Vol, veh/h	0	660	60	67	751	32	0	0	163	113	8	125
Future Vol, veh/h	0	660	60	67	751	32	0	0	163	113	8	125
Conflicting Peds, #/hr	0	0	0	0	0	0	0	0	0	0	0	0
Sign Control	Free	Free	Free	Free	Free	Free	Stop	Stop	Stop	Stop	Stop	Stop
RT Channelized	-	-	None	-	-	None	-	-	None	-	-	None
Storage Length	-	-	-	150	-	-	-	-	0	-	-	-
Veh in Median Storage, #	-	0	-	-	0	-	-	0	-	-	2	-
Grade, %	-	0	-	-	0	-	-	0	-	-	0	-
Peak Hour Factor	95	95	95	95	95	95	95	95	95	95	95	95
Heavy Vehicles, %	2	2	2	2	2	2	2	2	2	2	2	2
Mvmt Flow	0	695	63	71	791	34	0	0	172	119	8	132

Major/Minor	Major1			Major2			Minor1			Minor2		
Conflicting Flow All	-	0	0	758	0	0	-	-	379	1298	1708	413
Stage 1	-	-	-	-	-	-	-	-	-	950	950	-
Stage 2	-	-	-	-	-	-	-	-	-	348	758	-
Critical Hdwy	-	-	-	4.14	-	-	-	-	6.94	7.54	6.54	6.94
Critical Hdwy Stg 1	-	-	-	-	-	-	-	-	-	6.54	5.54	-
Critical Hdwy Stg 2	-	-	-	-	-	-	-	-	-	6.54	5.54	-
Follow-up Hdwy	-	-	-	2.22	-	-	-	-	3.32	3.52	4.02	3.32
Pot Cap-1 Maneuver	0	-	-	849	-	-	0	0	619	119	90	588
Stage 1	0	-	-	-	-	-	0	0	-	280	337	-
Stage 2	0	-	-	-	-	-	0	0	-	641	413	-
Platoon blocked, %		-	-	-	-	-						
Mov Cap-1 Maneuver	-	-	-	849	-	-	-	-	619	~ 81	82	588
Mov Cap-2 Maneuver	-	-	-	-	-	-	-	-	-	228	231	-
Stage 1	-	-	-	-	-	-	-	-	-	280	309	-
Stage 2	-	-	-	-	-	-	-	-	-	463	413	-

Approach	EB			WB			NB			SB		
HCM Control Delay, s	0			0.8			13			45.8		
HCM LOS							B			E		

Minor Lane/Major Mvmt	NBLn1	EBT	EBR	WBL	WBT	WBR	SBLn1
Capacity (veh/h)	619	-	-	849	-	-	331
HCM Lane V/C Ratio	0.277	-	-	0.083	-	-	0.782
HCM Control Delay (s)	13	-	-	9.6	-	-	45.8
HCM Lane LOS	B	-	-	A	-	-	E
HCM 95th %tile Q(veh)	1.1	-	-	0.3	-	-	6.3

Notes
 -: Volume exceeds capacity \$: Delay exceeds 300s +: Computation Not Defined *: All major volume in platoon

Timings

1: US 19 & Spring Hill Dr

08/10/2022



Lane Group	EBL	EBT	EBR	WBL	WBT	WBR	NBL	NBT	NBR	SBL	SBT	SBR
Lane Configurations												
Traffic Volume (vph)	172	118	110	424	148	218	66	928	200	283	1060	46
Future Volume (vph)	172	118	110	424	148	218	66	928	200	283	1060	46
Confl. Peds. (#/hr)												
Confl. Bikes (#/hr)												
Peak Hour Factor	0.95	0.95	0.95	0.95	0.95	0.95	0.95	0.95	0.95	0.95	0.95	0.95
Growth Factor	100%	100%	100%	100%	100%	100%	100%	100%	100%	100%	100%	100%
Heavy Vehicles (%)	2%	2%	2%	2%	2%	2%	2%	2%	2%	2%	2%	2%
Bus Blockages (#/hr)	0	0	0	0	0	0	0	0	0	0	0	0
Parking (#/hr)												
Mid-Block Traffic (%)		0%			0%			0%			0%	
Shared Lane Traffic (%)												
Turn Type	Prot	NA	Perm	Prot	NA	Perm	Prot	NA	Perm	Prot	NA	Perm
Protected Phases	3	8		7	4		1	6		5	2	
Permitted Phases			8			4			6			2
Detector Phase	3	8	8	7	4	4	1	6	6	5	2	2
Switch Phase												
Minimum Initial (s)	5.0	10.0	10.0	5.0	10.0	10.0	5.0	20.0	20.0	5.0	20.0	20.0
Minimum Split (s)	14.0	18.0	18.0	14.0	18.0	18.0	14.0	28.2	28.2	14.0	28.2	28.2
Total Split (s)	25.0	25.0	25.0	30.0	30.0	30.0	20.0	55.0	55.0	30.0	65.0	65.0
Total Split (%)	17.9%	17.9%	17.9%	21.4%	21.4%	21.4%	14.3%	39.3%	39.3%	21.4%	46.4%	46.4%
Yellow Time (s)	4.5	4.5	4.5	4.5	4.5	4.5	5.6	5.6	5.6	5.6	5.6	5.6
All-Red Time (s)	3.5	3.5	3.5	3.5	3.5	3.5	2.6	2.6	2.6	2.6	2.6	2.6
Lost Time Adjust (s)	0.0	0.0	0.0	0.0	0.0	0.0	0.0	0.0	0.0	0.0	0.0	0.0
Total Lost Time (s)	8.0	8.0	8.0	8.0	8.0	8.0	8.2	8.2	8.2	8.2	8.2	8.2
Lead/Lag	Lead	Lag	Lag	Lead	Lag	Lag	Lead	Lag	Lag	Lead	Lag	Lag
Lead-Lag Optimize?	Yes	Yes	Yes	Yes	Yes	Yes	Yes	Yes	Yes	Yes	Yes	Yes
Recall Mode	None	None	None	None	None	None	None	C-Max	C-Max	None	C-Max	C-Max
Act Effect Green (s)	12.7	11.8	11.8	21.2	20.2	20.2	10.2	57.3	57.3	17.4	67.5	67.5
Actuated g/C Ratio	0.09	0.08	0.08	0.15	0.14	0.14	0.07	0.41	0.41	0.12	0.48	0.48
v/c Ratio	0.58	0.42	0.34	0.86	0.58	0.54	0.54	0.47	0.27	0.70	0.46	0.06
Control Delay	68.5	64.7	2.6	74.8	65.1	11.0	77.6	32.2	3.7	67.6	26.3	0.1
Queue Delay	0.0	0.0	0.0	0.0	0.0	0.0	0.0	0.0	0.0	0.0	0.0	0.0
Total Delay	68.5	64.7	2.6	74.8	65.1	11.0	77.6	32.2	3.7	67.6	26.3	0.1
LOS	E	E	A	E	E	B	E	C	A	E	C	A
Approach Delay		49.2			55.4			29.9			33.9	
Approach LOS		D			E			C			C	

Intersection Summary

Cycle Length: 140	
Actuated Cycle Length: 140	
Offset: 55 (39%), Referenced to phase 2:SBT and 6:NBT, Start of Green	
Natural Cycle: 80	
Control Type: Actuated-Coordinated	
Maximum v/c Ratio: 0.86	
Intersection Signal Delay: 38.8	Intersection LOS: D
Intersection Capacity Utilization 73.4%	ICU Level of Service D
Analysis Period (min) 15	

Timings

1: US 19 & Spring Hill Dr

08/10/2022

Splits and Phases: 1: US 19 & Spring Hill Dr



HCM 6th TWSC
2: US 19 & Osowaw Blvd/Driveway B

08/10/2022

Intersection												
Int Delay, s/veh	1.7											
Movement	EBL	EBT	EBR	WBL	WBT	WBR	NBL	NBT	NBR	SBL	SBT	SBR
Lane Configurations			↗	↘		↗		↑↑↑	↗	↘	↑↑↑	↗
Traffic Vol, veh/h	0	0	8	49	0	40	0	1217	64	46	1336	101
Future Vol, veh/h	0	0	8	49	0	40	0	1217	64	46	1336	101
Conflicting Peds, #/hr	0	0	0	0	0	0	0	0	0	0	0	0
Sign Control	Stop	Stop	Stop	Stop	Stop	Stop	Free	Free	Free	Free	Free	Free
RT Channelized	-	-	Yield	-	-	None	-	-	None	-	-	Free
Storage Length	-	-	0	0	-	0	-	-	405	405	-	550
Veh in Median Storage, #	-	2	-	-	2	-	-	0	-	-	0	-
Grade, %	-	0	-	-	0	-	-	0	-	-	0	-
Peak Hour Factor	95	95	95	95	95	95	95	95	95	95	95	95
Heavy Vehicles, %	2	2	2	2	2	2	2	2	2	2	2	2
Mvmt Flow	0	0	8	52	0	42	0	1281	67	48	1406	106

Major/Minor	Minor2		Minor1		Major1			Major2				
Conflicting Flow All	-	-	703	1939	-	641	-	0	0	1348	0	0
Stage 1	-	-	-	1281	-	-	-	-	-	-	-	-
Stage 2	-	-	-	658	-	-	-	-	-	-	-	-
Critical Hdwy	-	-	7.14	6.44	-	7.14	-	-	-	5.34	-	-
Critical Hdwy Stg 1	-	-	-	7.34	-	-	-	-	-	-	-	-
Critical Hdwy Stg 2	-	-	-	6.74	-	-	-	-	-	-	-	-
Follow-up Hdwy	-	-	3.92	3.82	-	3.92	-	-	-	3.12	-	-
Pot Cap-1 Maneuver	0	0	326	69	0	358	0	-	-	265	-	0
Stage 1	0	0	-	127	0	-	0	-	-	-	-	0
Stage 2	0	0	-	382	0	-	0	-	-	-	-	0
Platoon blocked, %								-	-	-		
Mov Cap-1 Maneuver	-	-	326	58	-	358	-	-	-	265	-	-
Mov Cap-2 Maneuver	-	-	-	117	-	-	-	-	-	-	-	-
Stage 1	-	-	-	127	-	-	-	-	-	-	-	-
Stage 2	-	-	-	305	-	-	-	-	-	-	-	-

Approach	EB		WB		NB		SB	
HCM Control Delay, s	16.3		39.4		0		0.7	
HCM LOS	C		E					

Minor Lane/Major Mvmt	NBT	NBR	EBLn1WBLn1WBLn2	SBL	SBT
Capacity (veh/h)	-	-	326 117 358	265	-
HCM Lane V/C Ratio	-	-	0.026 0.441 0.118	0.183	-
HCM Control Delay (s)	-	-	16.3 58.1 16.4	21.6	-
HCM Lane LOS	-	-	C F C	C	-
HCM 95th %tile Q(veh)	-	-	0.1 1.9 0.4	0.7	-

HCM 6th TWSC
3: Pinehurst Dr & Spring Hill Dr

08/10/2022

Intersection												
Int Delay, s/veh	6.4											
Movement	EBL	EBT	EBR	WBL	WBT	WBR	NBL	NBT	NBR	SBL	SBT	SBR
Lane Configurations		↑↑		↑	↑↑				↑		↑↓	
Traffic Vol, veh/h	0	442	75	82	675	110	0	0	64	99	8	164
Future Vol, veh/h	0	442	75	82	675	110	0	0	64	99	8	164
Conflicting Peds, #/hr	0	0	0	0	0	0	0	0	0	0	0	0
Sign Control	Free	Free	Free	Free	Free	Free	Stop	Stop	Stop	Stop	Stop	Stop
RT Channelized	-	-	None	-	-	None	-	-	None	-	-	None
Storage Length	-	-	-	150	-	-	-	-	0	-	-	-
Veh in Median Storage, #	-	0	-	-	0	-	-	0	-	-	2	-
Grade, %	-	0	-	-	0	-	-	0	-	-	0	-
Peak Hour Factor	95	95	95	95	95	95	95	95	95	95	95	95
Heavy Vehicles, %	2	2	2	2	2	2	2	2	2	2	2	2
Mvmt Flow	0	465	79	86	711	116	0	0	67	104	8	173

Major/Minor	Major1			Major2			Minor1			Minor2		
Conflicting Flow All	-	0	0	544	0	0	-	-	272	1174	1485	414
Stage 1	-	-	-	-	-	-	-	-	-	941	941	-
Stage 2	-	-	-	-	-	-	-	-	-	233	544	-
Critical Hdwy	-	-	-	4.14	-	-	-	-	6.94	7.54	6.54	6.94
Critical Hdwy Stg 1	-	-	-	-	-	-	-	-	-	6.54	5.54	-
Critical Hdwy Stg 2	-	-	-	-	-	-	-	-	-	6.54	5.54	-
Follow-up Hdwy	-	-	-	2.22	-	-	-	-	3.32	3.52	4.02	3.32
Pot Cap-1 Maneuver	0	-	-	1021	-	-	0	0	726	147	124	587
Stage 1	0	-	-	-	-	-	0	0	-	283	340	-
Stage 2	0	-	-	-	-	-	0	0	-	749	517	-
Platoon blocked, %	-	-	-	-	-	-	-	-	-	-	-	-
Mov Cap-1 Maneuver	-	-	-	1021	-	-	-	-	726	125	114	587
Mov Cap-2 Maneuver	-	-	-	-	-	-	-	-	-	257	259	-
Stage 1	-	-	-	-	-	-	-	-	-	283	311	-
Stage 2	-	-	-	-	-	-	-	-	-	679	517	-

Approach	EB			WB			NB			SB		
HCM Control Delay, s	0			0.8			10.5			35.6		
HCM LOS							B			E		

Minor Lane/Major Mvmt	NBLn1	EBT	EBR	WBL	WBT	WBR	SBLn1
Capacity (veh/h)	726	-	-	1021	-	-	390
HCM Lane V/C Ratio	0.093	-	-	0.085	-	-	0.731
HCM Control Delay (s)	10.5	-	-	8.9	-	-	35.6
HCM Lane LOS	B	-	-	A	-	-	E
HCM 95th %tile Q(veh)	0.3	-	-	0.3	-	-	5.7

Timings

1: US 19 & Spring Hill Dr

08/11/2022



Lane Group	EBL	EBT	EBR	WBL	WBT	WBR	NBL	NBT	NBR	SBL	SBT	SBR
Lane Configurations												
Traffic Volume (vph)	212	191	55	342	141	290	83	1373	253	345	949	70
Future Volume (vph)	212	191	55	342	141	290	83	1373	253	345	949	70
Confl. Peds. (#/hr)												
Confl. Bikes (#/hr)												
Peak Hour Factor	0.95	0.95	0.95	0.95	0.95	0.95	0.95	0.95	0.95	0.95	0.95	0.95
Growth Factor	100%	100%	100%	100%	100%	100%	100%	100%	100%	100%	100%	100%
Heavy Vehicles (%)	2%	2%	2%	2%	2%	2%	2%	2%	2%	2%	2%	2%
Bus Blockages (#/hr)	0	0	0	0	0	0	0	0	0	0	0	0
Parking (#/hr)												
Mid-Block Traffic (%)		0%			0%			0%			0%	
Shared Lane Traffic (%)												
Turn Type	Prot	NA	Perm	Prot	NA	Perm	Prot	NA	Perm	Prot	NA	Perm
Protected Phases	3	8		7	4		1	6		5	2	
Permitted Phases			8			4			6			2
Detector Phase	3	8	8	7	4	4	1	6	6	5	2	2
Switch Phase												
Minimum Initial (s)	5.0	10.0	10.0	5.0	10.0	10.0	5.0	20.0	20.0	5.0	20.0	20.0
Minimum Split (s)	14.0	18.0	18.0	14.0	18.0	18.0	14.0	28.2	28.2	14.0	28.2	28.2
Total Split (s)	25.0	25.0	25.0	28.0	28.0	28.0	20.0	59.0	59.0	28.0	67.0	67.0
Total Split (%)	17.9%	17.9%	17.9%	20.0%	20.0%	20.0%	14.3%	42.1%	42.1%	20.0%	47.9%	47.9%
Yellow Time (s)	4.5	4.5	4.5	4.5	4.5	4.5	5.6	5.6	5.6	5.6	5.6	5.6
All-Red Time (s)	3.5	3.5	3.5	3.5	3.5	3.5	2.6	2.6	2.6	2.6	2.6	2.6
Lost Time Adjust (s)	0.0	0.0	0.0	0.0	0.0	0.0	0.0	0.0	0.0	0.0	0.0	0.0
Total Lost Time (s)	8.0	8.0	8.0	8.0	8.0	8.0	8.2	8.2	8.2	8.2	8.2	8.2
Lead/Lag	Lead	Lag	Lag	Lead	Lag	Lag	Lead	Lag	Lag	Lead	Lag	Lag
Lead-Lag Optimize?	Yes	Yes	Yes	Yes	Yes	Yes	Yes	Yes	Yes	Yes	Yes	Yes
Recall Mode	None	None	None	None	None	None	None	C-Max	C-Max	None	C-Max	C-Max
Act Effect Green (s)	14.1	13.8	13.8	18.5	18.2	18.2	10.7	56.8	56.8	18.5	64.6	64.6
Actuated g/C Ratio	0.10	0.10	0.10	0.13	0.13	0.13	0.08	0.41	0.41	0.13	0.46	0.46
v/c Ratio	0.64	0.58	0.19	0.79	0.61	0.83	0.64	0.70	0.33	0.80	0.43	0.09
Control Delay	69.1	66.7	1.4	72.3	68.7	42.6	84.1	37.8	4.5	72.8	26.8	0.2
Queue Delay	0.0	0.0	0.0	0.0	0.0	0.0	0.0	0.0	0.0	0.0	0.0	0.0
Total Delay	69.1	66.7	1.4	72.3	68.7	42.6	84.1	37.8	4.5	72.8	26.8	0.2
LOS	E	E	A	E	E	D	F	D	A	E	C	A
Approach Delay		59.9			60.5			35.1			37.1	
Approach LOS		E			E			D			D	

Intersection Summary

Cycle Length: 140

Actuated Cycle Length: 140

Offset: 59 (42%), Referenced to phase 2:SBT and 6:NBT, Start of Green

Natural Cycle: 90

Control Type: Actuated-Coordinated

Maximum v/c Ratio: 0.83

Intersection Signal Delay: 42.9

Intersection LOS: D

Intersection Capacity Utilization 81.5%

ICU Level of Service D

Analysis Period (min) 15

Timings

1: US 19 & Spring Hill Dr

08/11/2022

Splits and Phases: 1: US 19 & Spring Hill Dr



HCM 6th TWSC
2: US 19 & Osowaw Blvd/Driveway B

08/11/2022

Intersection												
Int Delay, s/veh	4.1											
Movement	EBL	EBT	EBR	WBL	WBT	WBR	NBL	NBT	NBR	SBL	SBT	SBR
Lane Configurations			↗	↘		↗		↑↑↑	↗	↘	↑↑↑	↗
Traffic Vol, veh/h	0	0	12	42	0	44	0	1766	71	36	1326	112
Future Vol, veh/h	0	0	12	42	0	44	0	1766	71	36	1326	112
Conflicting Peds, #/hr	0	0	0	0	0	0	0	0	0	0	0	0
Sign Control	Stop	Stop	Stop	Stop	Stop	Stop	Free	Free	Free	Free	Free	Free
RT Channelized	-	-	Yield	-	-	None	-	-	None	-	-	Free
Storage Length	-	-	0	0	-	0	-	-	405	405	-	550
Veh in Median Storage, #	-	2	-	-	2	-	-	0	-	-	0	-
Grade, %	-	0	-	-	0	-	-	0	-	-	0	-
Peak Hour Factor	95	95	95	95	95	95	95	95	95	95	95	95
Heavy Vehicles, %	2	2	2	2	2	2	2	2	2	2	2	2
Mvmt Flow	0	0	13	44	0	46	0	1859	75	38	1396	118

Major/Minor	Minor2		Minor1		Major1			Major2				
Conflicting Flow All	-	-	698	2493	-	930	-	0	0	1934	0	0
Stage 1	-	-	-	1859	-	-	-	-	-	-	-	-
Stage 2	-	-	-	634	-	-	-	-	-	-	-	-
Critical Hdwy	-	-	7.14	6.44	-	7.14	-	-	-	5.34	-	-
Critical Hdwy Stg 1	-	-	-	7.34	-	-	-	-	-	-	-	-
Critical Hdwy Stg 2	-	-	-	6.74	-	-	-	-	-	-	-	-
Follow-up Hdwy	-	-	3.92	3.82	-	3.92	-	-	-	3.12	-	-
Pot Cap-1 Maneuver	0	0	328	~ 31	0	231	0	-	-	135	-	0
Stage 1	0	0	-	49	0	-	0	-	-	-	-	0
Stage 2	0	0	-	395	0	-	0	-	-	-	-	0
Platoon blocked, %								-	-	-		
Mov Cap-1 Maneuver	-	-	328	~ 23	-	231	-	-	-	135	-	-
Mov Cap-2 Maneuver	-	-	-	46	-	-	-	-	-	-	-	-
Stage 1	-	-	-	49	-	-	-	-	-	-	-	-
Stage 2	-	-	-	273	-	-	-	-	-	-	-	-

Approach	EB		WB		NB		SB	
HCM Control Delay, s	16.4		138.9		0		1.1	
HCM LOS	C		F					

Minor Lane/Major Mvmt	NBT	NBR	EBLn1	WBLn1	WBLn2	SBL	SBT
Capacity (veh/h)	-	-	328	46	231	135	-
HCM Lane V/C Ratio	-	-	0.039	0.961	0.201	0.281	-
HCM Control Delay (s)	-	-	16.4	258.7	24.5	41.8	-
HCM Lane LOS	-	-	C	F	C	E	-
HCM 95th %tile Q(veh)	-	-	0.1	4	0.7	1.1	-

Notes
 -: Volume exceeds capacity \$: Delay exceeds 300s +: Computation Not Defined *: All major volume in platoon

HCM 6th TWSC
3: Pinehurst Dr & Spring Hill Dr

08/11/2022

Intersection												
Int Delay, s/veh	6.7											
Movement	EBL	EBT	EBR	WBL	WBT	WBR	NBL	NBT	NBR	SBL	SBT	SBR
Lane Configurations		↑↑		↑	↑↑				↑		↑↓	
Traffic Vol, veh/h	0	660	60	67	680	103	0	0	163	113	8	125
Future Vol, veh/h	0	660	60	67	680	103	0	0	163	113	8	125
Conflicting Peds, #/hr	0	0	0	0	0	0	0	0	0	0	0	0
Sign Control	Free	Free	Free	Free	Free	Free	Stop	Stop	Stop	Stop	Stop	Stop
RT Channelized	-	-	None	-	-	None	-	-	None	-	-	None
Storage Length	-	-	-	150	-	-	-	-	0	-	-	-
Veh in Median Storage, #	-	0	-	-	0	-	-	0	-	-	2	-
Grade, %	-	0	-	-	0	-	-	0	-	-	0	-
Peak Hour Factor	95	95	95	95	95	95	95	95	95	95	95	95
Heavy Vehicles, %	2	2	2	2	2	2	2	2	2	2	2	2
Mvmt Flow	0	695	63	71	716	108	0	0	172	119	8	132

Major/Minor	Major1			Major2			Minor1			Minor2		
Conflicting Flow All	-	0	0	758	0	0	-	-	379	1260	1670	412
Stage 1	-	-	-	-	-	-	-	-	-	912	912	-
Stage 2	-	-	-	-	-	-	-	-	-	348	758	-
Critical Hdwy	-	-	-	4.14	-	-	-	-	6.94	7.54	6.54	6.94
Critical Hdwy Stg 1	-	-	-	-	-	-	-	-	-	6.54	5.54	-
Critical Hdwy Stg 2	-	-	-	-	-	-	-	-	-	6.54	5.54	-
Follow-up Hdwy	-	-	-	2.22	-	-	-	-	3.32	3.52	4.02	3.32
Pot Cap-1 Maneuver	0	-	-	849	-	-	0	0	619	127	95	589
Stage 1	0	-	-	-	-	-	0	0	-	295	351	-
Stage 2	0	-	-	-	-	-	0	0	-	641	413	-
Platoon blocked, %	-	-	-	-	-	-	-	-	-	-	-	-
Mov Cap-1 Maneuver	-	-	-	849	-	-	-	-	619	~ 86	87	589
Mov Cap-2 Maneuver	-	-	-	-	-	-	-	-	-	237	237	-
Stage 1	-	-	-	-	-	-	-	-	-	295	322	-
Stage 2	-	-	-	-	-	-	-	-	-	463	413	-

Approach	EB			WB			NB			SB		
HCM Control Delay, s	0			0.8			13			42.6		
HCM LOS							B			E		

Minor Lane/Major Mvmt	NBLn1	EBT	EBR	WBL	WBT	WBR	SBLn1
Capacity (veh/h)	619	-	-	849	-	-	340
HCM Lane V/C Ratio	0.277	-	-	0.083	-	-	0.762
HCM Control Delay (s)	13	-	-	9.6	-	-	42.6
HCM Lane LOS	B	-	-	A	-	-	E
HCM 95th %tile Q(veh)	1.1	-	-	0.3	-	-	6

Notes
 -: Volume exceeds capacity \$: Delay exceeds 300s +: Computation Not Defined *: All major volume in platoon

Timings

1: US 19 & Spring Hill Dr

11/18/2022



Lane Group	EBL	EBT	EBR	WBL	WBT	WBR	NBL	NBT	NBR	SBL	SBT	SBR
Lane Configurations												
Traffic Volume (vph)	172	118	110	307	126	254	66	928	200	283	1177	68
Future Volume (vph)	172	118	110	307	126	254	66	928	200	283	1177	68
Confl. Peds. (#/hr)												
Confl. Bikes (#/hr)												
Peak Hour Factor	0.95	0.95	0.95	0.95	0.95	0.95	0.95	0.95	0.95	0.95	0.95	0.95
Growth Factor	100%	100%	100%	100%	100%	100%	100%	100%	100%	100%	100%	100%
Heavy Vehicles (%)	2%	2%	2%	2%	2%	2%	2%	2%	2%	2%	2%	2%
Bus Blockages (#/hr)	0	0	0	0	0	0	0	0	0	0	0	0
Parking (#/hr)												
Mid-Block Traffic (%)		0%			0%			0%			0%	
Shared Lane Traffic (%)												
Turn Type	Prot	NA	Perm	Prot	NA	Perm	Prot	NA	Perm	Prot	NA	Perm
Protected Phases	3	8		7	4		1	6		5	2	
Permitted Phases			8			4			6			2
Detector Phase	3	8	8	7	4	4	1	6	6	5	2	2
Switch Phase												
Minimum Initial (s)	5.0	10.0	10.0	5.0	10.0	10.0	5.0	20.0	20.0	5.0	20.0	20.0
Minimum Split (s)	14.0	18.0	18.0	14.0	18.0	18.0	14.0	28.2	28.2	14.0	28.2	28.2
Total Split (s)	25.0	25.0	25.0	30.0	30.0	30.0	20.0	55.0	55.0	30.0	65.0	65.0
Total Split (%)	17.9%	17.9%	17.9%	21.4%	21.4%	21.4%	14.3%	39.3%	39.3%	21.4%	46.4%	46.4%
Yellow Time (s)	4.5	4.5	4.5	4.5	4.5	4.5	5.6	5.6	5.6	5.6	5.6	5.6
All-Red Time (s)	3.5	3.5	3.5	3.5	3.5	3.5	2.6	2.6	2.6	2.6	2.6	2.6
Lost Time Adjust (s)	0.0	0.0	0.0	0.0	0.0	0.0	0.0	0.0	0.0	0.0	0.0	0.0
Total Lost Time (s)	8.0	8.0	8.0	8.0	8.0	8.0	8.2	8.2	8.2	8.2	8.2	8.2
Lead/Lag	Lead	Lag	Lag	Lead	Lag	Lag	Lead	Lag	Lag	Lead	Lag	Lag
Lead-Lag Optimize?	Yes	Yes	Yes	Yes	Yes	Yes	Yes	Yes	Yes	Yes	Yes	Yes
Recall Mode	None	None	None	None	None	None	None	C-Max	C-Max	None	C-Max	C-Max
Act Effct Green (s)	12.7	11.5	11.5	18.2	17.0	17.0	10.4	60.5	60.5	17.4	70.5	70.5
Actuated g/C Ratio	0.09	0.08	0.08	0.13	0.12	0.12	0.07	0.43	0.43	0.12	0.50	0.50
v/c Ratio	0.58	0.43	0.34	0.73	0.59	0.67	0.53	0.44	0.26	0.70	0.48	0.08
Control Delay	68.5	65.3	2.7	68.1	68.8	18.4	76.2	30.0	3.6	67.6	25.5	0.2
Queue Delay	0.0	0.0	0.0	0.0	0.0	0.0	0.0	0.0	0.0	0.0	0.0	0.0
Total Delay	68.5	65.3	2.7	68.1	68.8	18.4	76.2	30.0	3.6	67.6	25.5	0.2
LOS	E	E	A	E	E	B	E	C	A	E	C	A
Approach Delay		49.4			49.9			28.1			32.2	
Approach LOS		D			D			C			C	

Intersection Summary

Cycle Length: 140

Actuated Cycle Length: 140

Offset: 55 (39%), Referenced to phase 2:SBT and 6:NBT, Start of Green

Natural Cycle: 75

Control Type: Actuated-Coordinated

Maximum v/c Ratio: 0.73

Intersection Signal Delay: 35.9

Intersection LOS: D

Intersection Capacity Utilization 71.0%

ICU Level of Service C

Analysis Period (min) 15

Timings

1: US 19 & Spring Hill Dr

11/18/2022

Splits and Phases: 1: US 19 & Spring Hill Dr



HCM 6th TWSC
2: US 19 & Osowaw Blvd/Driveway B

11/18/2022

Intersection												
Int Delay, s/veh	21.9											
Movement	EBL	EBT	EBR	WBL	WBT	WBR	NBL	NBT	NBR	SBL	SBT	SBR
Lane Configurations			↗	↘		↗		↑↑↑		↗	↑↑↑	↗
Traffic Vol, veh/h	0	0	8	173	0	40	0	1217	93	46	1351	101
Future Vol, veh/h	0	0	8	173	0	40	0	1217	93	46	1351	101
Conflicting Peds, #/hr	0	0	0	0	0	0	0	0	0	0	0	0
Sign Control	Stop	Stop	Stop	Stop	Stop	Stop	Free	Free	Free	Free	Free	Free
RT Channelized	-	-	Yield	-	-	None	-	-	None	-	-	Free
Storage Length	-	-	0	0	-	0	-	-	405	405	-	550
Veh in Median Storage, #	-	2	-	-	2	-	-	0	-	-	0	-
Grade, %	-	0	-	-	0	-	-	0	-	-	0	-
Peak Hour Factor	95	95	95	95	95	95	95	95	95	95	95	95
Heavy Vehicles, %	2	2	2	2	2	2	2	2	2	2	2	2
Mvmt Flow	0	0	8	182	0	42	0	1281	98	48	1422	106

Major/Minor	Minor2		Minor1		Major1		Major2	
Conflicting Flow All	-	-	711	1946	-	641	-	0
Stage 1	-	-	-	1281	-	-	-	-
Stage 2	-	-	-	665	-	-	-	-
Critical Hdwy	-	-	7.14	6.44	-	7.14	-	5.34
Critical Hdwy Stg 1	-	-	-	7.34	-	-	-	-
Critical Hdwy Stg 2	-	-	-	6.74	-	-	-	-
Follow-up Hdwy	-	-	3.92	3.82	-	3.92	-	3.12
Pot Cap-1 Maneuver	0	0	322	~ 69	0	358	0	256
Stage 1	0	0	-	~ 127	0	-	0	-
Stage 2	0	0	-	378	0	-	0	-
Platoon blocked, %								
Mov Cap-1 Maneuver	-	-	322	~ 57	-	358	-	256
Mov Cap-2 Maneuver	-	-	-	~ 116	-	-	-	-
Stage 1	-	-	-	~ 127	-	-	-	-
Stage 2	-	-	-	299	-	-	-	-

Approach	EB	WB	NB	SB
HCM Control Delay, s	16.5	295.6	0	0.7
HCM LOS	C	F		

Minor Lane/Major Mvmt	NBT	NBR	EBLn1	WBLn1	WBLn2	SBL	SBT
Capacity (veh/h)	-	-	322	116	358	256	-
HCM Lane V/C Ratio	-	-	0.026	1.57	0.118	0.189	-
HCM Control Delay (s)	-	-	16.5	360.1	16.4	22.3	-
HCM Lane LOS	-	-	C	F	C	C	-
HCM 95th %tile Q(veh)	-	-	0.1	13.4	0.4	0.7	-

Notes
 -: Volume exceeds capacity \$: Delay exceeds 300s +: Computation Not Defined *: All major volume in platoon

HCM 6th TWSC
3: Pinehurst Dr & Spring Hill Dr

11/18/2022

Intersection												
Int Delay, s/veh	1.4											
Movement	EBL	EBT	EBR	WBL	WBT	WBR	NBL	NBT	NBR	SBL	SBT	SBR
Lane Configurations		↑↓		↑	↑↓				↑		↑↓	
Traffic Vol, veh/h	0	442	75	82	707	27	0	0	64	5	8	25
Future Vol, veh/h	0	442	75	82	707	27	0	0	64	5	8	25
Conflicting Peds, #/hr	0	0	0	0	0	0	0	0	0	0	0	0
Sign Control	Free	Free	Free	Free	Free	Free	Stop	Stop	Stop	Stop	Stop	Stop
RT Channelized	-	-	None	-	-	None	-	-	None	-	-	None
Storage Length	-	-	-	150	-	-	-	-	0	-	-	-
Veh in Median Storage, #	-	0	-	-	0	-	-	0	-	-	2	-
Grade, %	-	0	-	-	0	-	-	0	-	-	0	-
Peak Hour Factor	95	95	95	95	95	95	95	95	95	95	95	95
Heavy Vehicles, %	2	2	2	2	2	2	2	2	2	2	2	2
Mvmt Flow	0	465	79	86	744	28	0	0	67	5	8	26

Major/Minor	Major1			Major2			Minor1			Minor2		
Conflicting Flow All	-	0	0	544	0	0	-	-	272	1163	1474	386
Stage 1	-	-	-	-	-	-	-	-	-	930	930	-
Stage 2	-	-	-	-	-	-	-	-	-	233	544	-
Critical Hdwy	-	-	-	4.14	-	-	-	-	6.94	7.54	6.54	6.94
Critical Hdwy Stg 1	-	-	-	-	-	-	-	-	-	6.54	5.54	-
Critical Hdwy Stg 2	-	-	-	-	-	-	-	-	-	6.54	5.54	-
Follow-up Hdwy	-	-	-	2.22	-	-	-	-	3.32	3.52	4.02	3.32
Pot Cap-1 Maneuver	0	-	-	1021	-	-	0	0	726	150	125	612
Stage 1	0	-	-	-	-	-	0	0	-	287	344	-
Stage 2	0	-	-	-	-	-	0	0	-	749	517	-
Platoon blocked, %	-	-	-	-	-	-	-	-	-	-	-	-
Mov Cap-1 Maneuver	-	-	-	1021	-	-	-	-	726	127	115	612
Mov Cap-2 Maneuver	-	-	-	-	-	-	-	-	-	260	262	-
Stage 1	-	-	-	-	-	-	-	-	-	287	315	-
Stage 2	-	-	-	-	-	-	-	-	-	679	517	-

Approach	EB			WB			NB			SB		
HCM Control Delay, s	0			0.9			10.5			14.5		
HCM LOS							B			B		

Minor Lane/Major Mvmt	NBLn1	EBT	EBR	WBL	WBT	WBR	SBLn1
Capacity (veh/h)	726	-	-	1021	-	-	419
HCM Lane V/C Ratio	0.093	-	-	0.085	-	-	0.095
HCM Control Delay (s)	10.5	-	-	8.9	-	-	14.5
HCM Lane LOS	B	-	-	A	-	-	B
HCM 95th %tile Q(veh)	0.3	-	-	0.3	-	-	0.3

Timings

1: US 19 & Spring Hill Dr

11/18/2022



Lane Group	EBL	EBT	EBR	WBL	WBT	WBR	NBL	NBT	NBR	SBL	SBT	SBR
Lane Configurations												
Traffic Volume (vph)	212	191	55	262	120	321	83	1373	253	345	1029	91
Future Volume (vph)	212	191	55	262	120	321	83	1373	253	345	1029	91
Confl. Peds. (#/hr)												
Confl. Bikes (#/hr)												
Peak Hour Factor	0.95	0.95	0.95	0.95	0.95	0.95	0.95	0.95	0.95	0.95	0.95	0.95
Growth Factor	100%	100%	100%	100%	100%	100%	100%	100%	100%	100%	100%	100%
Heavy Vehicles (%)	2%	2%	2%	2%	2%	2%	2%	2%	2%	2%	2%	2%
Bus Blockages (#/hr)	0	0	0	0	0	0	0	0	0	0	0	0
Parking (#/hr)												
Mid-Block Traffic (%)		0%			0%			0%			0%	
Shared Lane Traffic (%)												
Turn Type	Prot	NA	Perm	Prot	NA	Perm	Prot	NA	Perm	Prot	NA	Perm
Protected Phases	3	8		7	4		1	6		5	2	
Permitted Phases			8			4			6			2
Detector Phase	3	8	8	7	4	4	1	6	6	5	2	2
Switch Phase												
Minimum Initial (s)	5.0	10.0	10.0	5.0	10.0	10.0	5.0	20.0	20.0	5.0	20.0	20.0
Minimum Split (s)	14.0	18.0	18.0	14.0	18.0	18.0	14.0	28.2	28.2	14.0	28.2	28.2
Total Split (s)	25.0	25.0	25.0	28.0	28.0	28.0	20.0	59.0	59.0	28.0	67.0	67.0
Total Split (%)	17.9%	17.9%	17.9%	20.0%	20.0%	20.0%	14.3%	42.1%	42.1%	20.0%	47.9%	47.9%
Yellow Time (s)	4.5	4.5	4.5	4.5	4.5	4.5	5.6	5.6	5.6	5.6	5.6	5.6
All-Red Time (s)	3.5	3.5	3.5	3.5	3.5	3.5	2.6	2.6	2.6	2.6	2.6	2.6
Lost Time Adjust (s)	0.0	0.0	0.0	0.0	0.0	0.0	0.0	0.0	0.0	0.0	0.0	0.0
Total Lost Time (s)	8.0	8.0	8.0	8.0	8.0	8.0	8.2	8.2	8.2	8.2	8.2	8.2
Lead/Lag	Lead	Lag	Lag	Lead	Lag	Lag	Lead	Lag	Lag	Lead	Lag	Lag
Lead-Lag Optimize?	Yes	Yes	Yes	Yes	Yes	Yes	Yes	Yes	Yes	Yes	Yes	Yes
Recall Mode	None	None	None	None	None	None	None	C-Max	C-Max	None	C-Max	C-Max
Act Effct Green (s)	14.1	16.5	16.5	16.3	18.7	18.7	10.6	56.3	56.3	18.5	64.1	64.1
Actuated g/C Ratio	0.10	0.12	0.12	0.12	0.13	0.13	0.08	0.40	0.40	0.13	0.46	0.46
v/c Ratio	0.64	0.48	0.17	0.69	0.51	0.91	0.65	0.71	0.33	0.80	0.47	0.12
Control Delay	69.1	61.3	1.1	68.5	63.2	55.3	84.7	38.4	4.5	73.0	27.9	0.3
Queue Delay	0.0	0.0	0.0	0.0	0.0	0.0	0.0	0.0	0.0	0.0	0.0	0.0
Total Delay	69.1	61.3	1.1	68.5	63.2	55.3	84.7	38.4	4.5	73.0	27.9	0.3
LOS	E	E	A	E	E	E	F	D	A	E	C	A
Approach Delay		57.7			61.6			35.7			36.8	
Approach LOS		E			E			D			D	

Intersection Summary

Cycle Length: 140
 Actuated Cycle Length: 140
 Offset: 59 (42%), Referenced to phase 2:SBT and 6:NBT, Start of Green
 Natural Cycle: 90
 Control Type: Actuated-Coordinated
 Maximum v/c Ratio: 0.91
 Intersection Signal Delay: 42.6
 Intersection Capacity Utilization 79.2%
 Analysis Period (min) 15
 Intersection LOS: D
 ICU Level of Service D

Timings

1: US 19 & Spring Hill Dr

11/18/2022

Splits and Phases: 1: US 19 & Spring Hill Dr



HCM 6th TWSC
2: US 19 & Osowaw Blvd/Driveway B

11/18/2022

Intersection												
Int Delay, s/veh	43.2											
Movement	EBL	EBT	EBR	WBL	WBT	WBR	NBL	NBT	NBR	SBL	SBT	SBR
Lane Configurations			↗	↘		↗		↑↑↑	↗	↘	↑↑↑	↗
Traffic Vol, veh/h	0	0	12	132	0	44	0	1766	93	36	1337	112
Future Vol, veh/h	0	0	12	132	0	44	0	1766	93	36	1337	112
Conflicting Peds, #/hr	0	0	0	0	0	0	0	0	0	0	0	0
Sign Control	Stop	Stop	Stop	Stop	Stop	Stop	Free	Free	Free	Free	Free	Free
RT Channelized	-	-	Yield	-	-	None	-	-	None	-	-	Free
Storage Length	-	-	0	0	-	0	-	-	405	405	-	550
Veh in Median Storage, #	-	2	-	-	2	-	-	0	-	-	0	-
Grade, %	-	0	-	-	0	-	-	0	-	-	0	-
Peak Hour Factor	95	95	95	95	95	95	95	95	95	95	95	95
Heavy Vehicles, %	2	2	2	2	2	2	2	2	2	2	2	2
Mvmt Flow	0	0	13	139	0	46	0	1859	98	38	1407	118

Major/Minor	Minor2		Minor1		Major1			Major2				
Conflicting Flow All	-	-	704	2498	-	930	-	0	0	1957	0	0
Stage 1	-	-	-	1859	-	-	-	-	-	-	-	-
Stage 2	-	-	-	639	-	-	-	-	-	-	-	-
Critical Hdwy	-	-	7.14	6.44	-	7.14	-	-	-	5.34	-	-
Critical Hdwy Stg 1	-	-	-	7.34	-	-	-	-	-	-	-	-
Critical Hdwy Stg 2	-	-	-	6.74	-	-	-	-	-	-	-	-
Follow-up Hdwy	-	-	3.92	3.82	-	3.92	-	-	-	3.12	-	-
Pot Cap-1 Maneuver	0	0	325	~ 31	0	231	0	-	-	131	-	0
Stage 1	0	0	-	~ 49	0	-	0	-	-	-	-	0
Stage 2	0	0	-	392	0	-	0	-	-	-	-	0
Platoon blocked, %								-	-	-		
Mov Cap-1 Maneuver	-	-	325	~ 23	-	231	-	-	-	131	-	-
Mov Cap-2 Maneuver	-	-	-	~ 46	-	-	-	-	-	-	-	-
Stage 1	-	-	-	~ 49	-	-	-	-	-	-	-	-
Stage 2	-	-	-	267	-	-	-	-	-	-	-	-

Approach	EB		WB		NB		SB	
HCM Control Delay, s	16.5		\$ 829.2		0		1.1	
HCM LOS	C		F					

Minor Lane/Major Mvmt	NBT	NBR	EBLn1	WBLn1	WBLn2	SBL	SBT
Capacity (veh/h)	-	-	325	46	231	131	-
HCM Lane V/C Ratio	-	-	0.039	3.021	0.201	0.289	-
HCM Control Delay (s)	-	-	16.5	\$ 1097.4	24.5	43.3	-
HCM Lane LOS	-	-	C	F	C	E	-
HCM 95th %tile Q(veh)	-	-	0.1	15.1	0.7	1.1	-

Notes
 -: Volume exceeds capacity \$: Delay exceeds 300s +: Computation Not Defined *: All major volume in platoon

HCM 6th TWSC
3: Pinehurst Dr & Spring Hill Dr

11/18/2022

Intersection												
Int Delay, s/veh	2											
Movement	EBL	EBT	EBR	WBL	WBT	WBR	NBL	NBT	NBR	SBL	SBT	SBR
Lane Configurations		↑↑		↑	↑↑				↑		↑↓	
Traffic Vol, veh/h	0	660	60	67	709	32	0	0	163	13	8	24
Future Vol, veh/h	0	660	60	67	709	32	0	0	163	13	8	24
Conflicting Peds, #/hr	0	0	0	0	0	0	0	0	0	0	0	0
Sign Control	Free	Free	Free	Free	Free	Free	Stop	Stop	Stop	Stop	Stop	Stop
RT Channelized	-	-	None	-	-	None	-	-	None	-	-	None
Storage Length	-	-	-	150	-	-	-	-	0	-	-	-
Veh in Median Storage, #	-	0	-	-	0	-	-	0	-	-	2	-
Grade, %	-	0	-	-	0	-	-	0	-	-	0	-
Peak Hour Factor	95	95	95	95	95	95	95	95	95	95	95	95
Heavy Vehicles, %	2	2	2	2	2	2	2	2	2	2	2	2
Mvmt Flow	0	695	63	71	746	34	0	0	172	14	8	25

Major/Minor	Major1			Major2			Minor1			Minor2		
Conflicting Flow All	-	0	0	758	0	0	-	-	379	1253	1663	390
Stage 1	-	-	-	-	-	-	-	-	-	905	905	-
Stage 2	-	-	-	-	-	-	-	-	-	348	758	-
Critical Hdwy	-	-	-	4.14	-	-	-	-	6.94	7.54	6.54	6.94
Critical Hdwy Stg 1	-	-	-	-	-	-	-	-	-	6.54	5.54	-
Critical Hdwy Stg 2	-	-	-	-	-	-	-	-	-	6.54	5.54	-
Follow-up Hdwy	-	-	-	2.22	-	-	-	-	3.32	3.52	4.02	3.32
Pot Cap-1 Maneuver	0	-	-	849	-	-	0	0	619	129	96	609
Stage 1	0	-	-	-	-	-	0	0	-	298	353	-
Stage 2	0	-	-	-	-	-	0	0	-	641	413	-
Platoon blocked, %	-	-	-	-	-	-	-	-	-	-	-	-
Mov Cap-1 Maneuver	-	-	-	849	-	-	-	-	619	87	88	609
Mov Cap-2 Maneuver	-	-	-	-	-	-	-	-	-	239	238	-
Stage 1	-	-	-	-	-	-	-	-	-	298	323	-
Stage 2	-	-	-	-	-	-	-	-	-	463	413	-

Approach	EB			WB			NB			SB		
HCM Control Delay, s	0			0.8			13			16.8		
HCM LOS							B			C		

Minor Lane/Major Mvmt	NBLn1	EBT	EBR	WBL	WBT	WBR	SBLn1
Capacity (veh/h)	619	-	-	849	-	-	353
HCM Lane V/C Ratio	0.277	-	-	0.083	-	-	0.134
HCM Control Delay (s)	13	-	-	9.6	-	-	16.8
HCM Lane LOS	B	-	-	A	-	-	C
HCM 95th %tile Q(veh)	1.1	-	-	0.3	-	-	0.5

Timings

1: US 19 & Spring Hill Dr

11/18/2022



Lane Group	EBL	EBT	EBR	WBL	WBT	WBR	NBL	NBT	NBR	SBL	SBT	SBR
Lane Configurations	↔↔	↑↑	↗	↔↔	↑	↗	↗	↑↑↑	↗	↔↔	↑↑↑	↗
Traffic Volume (vph)	172	118	110	424	148	218	66	928	200	220	1060	46
Future Volume (vph)	172	118	110	424	148	218	66	928	200	220	1060	46
Confl. Peds. (#/hr)												
Confl. Bikes (#/hr)												
Peak Hour Factor	0.95	0.95	0.95	0.95	0.95	0.95	0.95	0.95	0.95	0.95	0.95	0.95
Growth Factor	100%	100%	100%	100%	100%	100%	100%	100%	100%	100%	100%	100%
Heavy Vehicles (%)	2%	2%	2%	2%	2%	2%	2%	2%	2%	2%	2%	2%
Bus Blockages (#/hr)	0	0	0	0	0	0	0	0	0	0	0	0
Parking (#/hr)												
Mid-Block Traffic (%)		0%			0%			0%			0%	
Shared Lane Traffic (%)												
Turn Type	Prot	NA	Perm	Prot	NA	Perm	Prot	NA	Perm	Prot	NA	Perm
Protected Phases	3	8		7	4		1	6		5	2	
Permitted Phases			8			4			6			2
Detector Phase	3	8	8	7	4	4	1	6	6	5	2	2
Switch Phase												
Minimum Initial (s)	5.0	10.0	10.0	5.0	10.0	10.0	5.0	20.0	20.0	5.0	20.0	20.0
Minimum Split (s)	14.0	18.0	18.0	14.0	18.0	18.0	14.0	28.2	28.2	14.0	28.2	28.2
Total Split (s)	25.0	25.0	25.0	30.0	30.0	30.0	20.0	55.0	55.0	30.0	65.0	65.0
Total Split (%)	17.9%	17.9%	17.9%	21.4%	21.4%	21.4%	14.3%	39.3%	39.3%	21.4%	46.4%	46.4%
Yellow Time (s)	4.5	4.5	4.5	4.5	4.5	4.5	5.6	5.6	5.6	5.6	5.6	5.6
All-Red Time (s)	3.5	3.5	3.5	3.5	3.5	3.5	2.6	2.6	2.6	2.6	2.6	2.6
Lost Time Adjust (s)	0.0	0.0	0.0	0.0	0.0	0.0	0.0	0.0	0.0	0.0	0.0	0.0
Total Lost Time (s)	8.0	8.0	8.0	8.0	8.0	8.0	8.2	8.2	8.2	8.2	8.2	8.2
Lead/Lag	Lead	Lag	Lag	Lead	Lag	Lag	Lead	Lag	Lag	Lead	Lag	Lag
Lead-Lag Optimize?	Yes	Yes	Yes	Yes	Yes	Yes	Yes	Yes	Yes	Yes	Yes	Yes
Recall Mode	None	None	None	None	None	None	None	C-Max	C-Max	None	C-Max	C-Max
Act Effect Green (s)	12.7	11.8	11.8	21.2	20.2	20.2	10.2	59.9	59.9	14.7	67.5	67.5
Actuated g/C Ratio	0.09	0.08	0.08	0.15	0.14	0.14	0.07	0.43	0.43	0.10	0.48	0.48
v/c Ratio	0.58	0.42	0.34	0.86	0.58	0.54	0.54	0.45	0.26	0.64	0.46	0.06
Control Delay	68.5	64.7	2.6	74.8	65.1	11.0	77.6	30.1	3.5	68.2	26.3	0.1
Queue Delay	0.0	0.0	0.0	0.0	0.0	0.0	0.0	0.0	0.0	0.0	0.0	0.0
Total Delay	68.5	64.7	2.6	74.8	65.1	11.0	77.6	30.1	3.5	68.2	26.3	0.1
LOS	E	E	A	E	E	B	E	C	A	E	C	A
Approach Delay		49.2			55.4			28.2			32.4	
Approach LOS		D			E			C			C	

Intersection Summary

Cycle Length: 140
 Actuated Cycle Length: 140
 Offset: 55 (39%), Referenced to phase 2:SBT and 6:NBT, Start of Green
 Natural Cycle: 80
 Control Type: Actuated-Coordinated
 Maximum v/c Ratio: 0.86
 Intersection Signal Delay: 37.8
 Intersection Capacity Utilization 72.1%
 Analysis Period (min) 15
 Intersection LOS: D
 ICU Level of Service C

Timings

1: US 19 & Spring Hill Dr

11/18/2022

Splits and Phases: 1: US 19 & Spring Hill Dr



HCM 6th TWSC
2: US 19 & Osowaw Blvd/Driveway B

11/18/2022

Intersection												
Int Delay, s/veh	1.7											
Movement	EBL	EBT	EBR	WBL	WBT	WBR	NBL	NBT	NBR	SBL	SBT	SBR
Lane Configurations			↗	↘		↗		↑↑↑		↗	↑↑↑	↗
Traffic Vol, veh/h	0	0	8	49	0	40	0	1217	64	46	1336	101
Future Vol, veh/h	0	0	8	49	0	40	0	1217	64	46	1336	101
Conflicting Peds, #/hr	0	0	0	0	0	0	0	0	0	0	0	0
Sign Control	Stop	Stop	Stop	Stop	Stop	Stop	Free	Free	Free	Free	Free	Free
RT Channelized	-	-	Yield	-	-	None	-	-	None	-	-	Free
Storage Length	-	-	0	0	-	0	-	-	405	405	-	550
Veh in Median Storage, #	-	2	-	-	2	-	-	0	-	-	0	-
Grade, %	-	0	-	-	0	-	-	0	-	-	0	-
Peak Hour Factor	95	95	95	95	95	95	95	95	95	95	95	95
Heavy Vehicles, %	2	2	2	2	2	2	2	2	2	2	2	2
Mvmt Flow	0	0	8	52	0	42	0	1281	67	48	1406	106

Major/Minor	Minor2		Minor1		Major1			Major2				
Conflicting Flow All	-	-	703	1939	-	641	-	0	0	1348	0	0
Stage 1	-	-	-	1281	-	-	-	-	-	-	-	-
Stage 2	-	-	-	658	-	-	-	-	-	-	-	-
Critical Hdwy	-	-	7.14	6.44	-	7.14	-	-	-	5.34	-	-
Critical Hdwy Stg 1	-	-	-	7.34	-	-	-	-	-	-	-	-
Critical Hdwy Stg 2	-	-	-	6.74	-	-	-	-	-	-	-	-
Follow-up Hdwy	-	-	3.92	3.82	-	3.92	-	-	-	3.12	-	-
Pot Cap-1 Maneuver	0	0	326	69	0	358	0	-	-	265	-	0
Stage 1	0	0	-	127	0	-	0	-	-	-	-	0
Stage 2	0	0	-	382	0	-	0	-	-	-	-	0
Platoon blocked, %								-	-	-		
Mov Cap-1 Maneuver	-	-	326	58	-	358	-	-	-	265	-	-
Mov Cap-2 Maneuver	-	-	-	117	-	-	-	-	-	-	-	-
Stage 1	-	-	-	127	-	-	-	-	-	-	-	-
Stage 2	-	-	-	305	-	-	-	-	-	-	-	-

Approach	EB		WB		NB		SB	
HCM Control Delay, s	16.3		39.4		0		0.7	
HCM LOS	C		E					

Minor Lane/Major Mvmt	NBT	NBR	EBLn1WBLn1WBLn2	SBL	SBT
Capacity (veh/h)	-	-	326 117 358	265	-
HCM Lane V/C Ratio	-	-	0.026 0.441 0.118	0.183	-
HCM Control Delay (s)	-	-	16.3 58.1 16.4	21.6	-
HCM Lane LOS	-	-	C F C	C	-
HCM 95th %tile Q(veh)	-	-	0.1 1.9 0.4	0.7	-

HCM 6th TWSC
3: Pinehurst Dr & Spring Hill Dr

11/18/2022

Intersection												
Int Delay, s/veh	5.1											
Movement	EBL	EBT	EBR	WBL	WBT	WBR	NBL	NBT	NBR	SBL	SBT	SBR
Lane Configurations		↑↓		↑	↑↓				↑		↑↓	
Traffic Vol, veh/h	0	442	75	82	671	102	0	0	64	80	8	164
Future Vol, veh/h	0	442	75	82	671	102	0	0	64	80	8	164
Conflicting Peds, #/hr	0	0	0	0	0	0	0	0	0	0	0	0
Sign Control	Free	Free	Free	Free	Free	Free	Stop	Stop	Stop	Stop	Stop	Stop
RT Channelized	-	-	None	-	-	None	-	-	None	-	-	None
Storage Length	-	-	-	150	-	-	-	-	0	-	-	-
Veh in Median Storage, #	-	0	-	-	0	-	-	0	-	-	2	-
Grade, %	-	0	-	-	0	-	-	0	-	-	0	-
Peak Hour Factor	95	95	95	95	95	95	95	95	95	95	95	95
Heavy Vehicles, %	2	2	2	2	2	2	2	2	2	2	2	2
Mvmt Flow	0	465	79	86	706	107	0	0	67	84	8	173

Major/Minor	Major1			Major2			Minor1			Minor2		
Conflicting Flow All	-	0	0	544	0	0	-	-	272	1165	1476	407
Stage 1	-	-	-	-	-	-	-	-	-	932	932	-
Stage 2	-	-	-	-	-	-	-	-	-	233	544	-
Critical Hdwy	-	-	-	4.14	-	-	-	-	6.94	7.54	6.54	6.94
Critical Hdwy Stg 1	-	-	-	-	-	-	-	-	-	6.54	5.54	-
Critical Hdwy Stg 2	-	-	-	-	-	-	-	-	-	6.54	5.54	-
Follow-up Hdwy	-	-	-	2.22	-	-	-	-	3.32	3.52	4.02	3.32
Pot Cap-1 Maneuver	0	-	-	1021	-	-	0	0	726	149	125	593
Stage 1	0	-	-	-	-	-	0	0	-	287	343	-
Stage 2	0	-	-	-	-	-	0	0	-	749	517	-
Platoon blocked, %	-	-	-	-	-	-	-	-	-	-	-	-
Mov Cap-1 Maneuver	-	-	-	1021	-	-	-	-	726	127	115	593
Mov Cap-2 Maneuver	-	-	-	-	-	-	-	-	-	260	261	-
Stage 1	-	-	-	-	-	-	-	-	-	287	314	-
Stage 2	-	-	-	-	-	-	-	-	-	679	517	-

Approach	EB			WB			NB			SB		
HCM Control Delay, s	0			0.8			10.5			28.5		
HCM LOS							B			D		

Minor Lane/Major Mvmt	NBLn1	EBT	EBR	WBL	WBT	WBR	SBLn1
Capacity (veh/h)	726	-	-	1021	-	-	410
HCM Lane V/C Ratio	0.093	-	-	0.085	-	-	0.647
HCM Control Delay (s)	10.5	-	-	8.9	-	-	28.5
HCM Lane LOS	B	-	-	A	-	-	D
HCM 95th %tile Q(veh)	0.3	-	-	0.3	-	-	4.4

Timings

1: US 19 & Spring Hill Dr

11/18/2022



Lane Group	EBL	EBT	EBR	WBL	WBT	WBR	NBL	NBT	NBR	SBL	SBT	SBR
Lane Configurations												
Traffic Volume (vph)	212	191	55	342	141	290	83	1373	253	345	949	70
Future Volume (vph)	212	191	55	342	141	290	83	1373	253	345	949	70
Confl. Peds. (#/hr)												
Confl. Bikes (#/hr)												
Peak Hour Factor	0.95	0.95	0.95	0.95	0.95	0.95	0.95	0.95	0.95	0.95	0.95	0.95
Growth Factor	100%	100%	100%	100%	100%	100%	100%	100%	100%	100%	100%	100%
Heavy Vehicles (%)	2%	2%	2%	2%	2%	2%	2%	2%	2%	2%	2%	2%
Bus Blockages (#/hr)	0	0	0	0	0	0	0	0	0	0	0	0
Parking (#/hr)												
Mid-Block Traffic (%)		0%			0%			0%			0%	
Shared Lane Traffic (%)												
Turn Type	Prot	NA	Perm	Prot	NA	Perm	Prot	NA	Perm	Prot	NA	Perm
Protected Phases	3	8		7	4		1	6		5	2	
Permitted Phases			8			4			6			2
Detector Phase	3	8	8	7	4	4	1	6	6	5	2	2
Switch Phase												
Minimum Initial (s)	5.0	10.0	10.0	5.0	10.0	10.0	5.0	20.0	20.0	5.0	20.0	20.0
Minimum Split (s)	14.0	18.0	18.0	14.0	18.0	18.0	14.0	28.2	28.2	14.0	28.2	28.2
Total Split (s)	25.0	25.0	25.0	28.0	28.0	28.0	20.0	59.0	59.0	28.0	67.0	67.0
Total Split (%)	17.9%	17.9%	17.9%	20.0%	20.0%	20.0%	14.3%	42.1%	42.1%	20.0%	47.9%	47.9%
Yellow Time (s)	4.5	4.5	4.5	4.5	4.5	4.5	5.6	5.6	5.6	5.6	5.6	5.6
All-Red Time (s)	3.5	3.5	3.5	3.5	3.5	3.5	2.6	2.6	2.6	2.6	2.6	2.6
Lost Time Adjust (s)	0.0	0.0	0.0	0.0	0.0	0.0	0.0	0.0	0.0	0.0	0.0	0.0
Total Lost Time (s)	8.0	8.0	8.0	8.0	8.0	8.0	8.2	8.2	8.2	8.2	8.2	8.2
Lead/Lag	Lead	Lag	Lag	Lead	Lag	Lag	Lead	Lag	Lag	Lead	Lag	Lag
Lead-Lag Optimize?	Yes	Yes	Yes	Yes	Yes	Yes	Yes	Yes	Yes	Yes	Yes	Yes
Recall Mode	None	None	None	None	None	None	None	C-Max	C-Max	None	C-Max	C-Max
Act Effect Green (s)	14.1	13.8	13.8	18.5	18.2	18.2	10.7	56.8	56.8	18.5	64.6	64.6
Actuated g/C Ratio	0.10	0.10	0.10	0.13	0.13	0.13	0.08	0.41	0.41	0.13	0.46	0.46
v/c Ratio	0.64	0.58	0.19	0.79	0.61	0.83	0.64	0.70	0.33	0.80	0.43	0.09
Control Delay	69.1	66.7	1.4	72.3	68.7	42.6	84.1	37.8	4.5	72.8	26.8	0.2
Queue Delay	0.0	0.0	0.0	0.0	0.0	0.0	0.0	0.0	0.0	0.0	0.0	0.0
Total Delay	69.1	66.7	1.4	72.3	68.7	42.6	84.1	37.8	4.5	72.8	26.8	0.2
LOS	E	E	A	E	E	D	F	D	A	E	C	A
Approach Delay		59.9			60.5			35.1			37.1	
Approach LOS		E			E			D			D	

Intersection Summary

Cycle Length: 140	
Actuated Cycle Length: 140	
Offset: 59 (42%), Referenced to phase 2:SBT and 6:NBT, Start of Green	
Natural Cycle: 90	
Control Type: Actuated-Coordinated	
Maximum v/c Ratio: 0.83	
Intersection Signal Delay: 42.9	Intersection LOS: D
Intersection Capacity Utilization 81.5%	ICU Level of Service D
Analysis Period (min) 15	

Timings

1: US 19 & Spring Hill Dr

11/18/2022

Splits and Phases: 1: US 19 & Spring Hill Dr



HCM 6th TWSC
2: US 19 & Osowaw Blvd/Driveway B

11/18/2022

Intersection												
Int Delay, s/veh	4.1											
Movement	EBL	EBT	EBR	WBL	WBT	WBR	NBL	NBT	NBR	SBL	SBT	SBR
Lane Configurations			↗	↘		↗		↑↑↑	↗	↘	↑↑↑	↗
Traffic Vol, veh/h	0	0	12	42	0	44	0	1766	71	36	1326	112
Future Vol, veh/h	0	0	12	42	0	44	0	1766	71	36	1326	112
Conflicting Peds, #/hr	0	0	0	0	0	0	0	0	0	0	0	0
Sign Control	Stop	Stop	Stop	Stop	Stop	Stop	Free	Free	Free	Free	Free	Free
RT Channelized	-	-	Yield	-	-	None	-	-	None	-	-	Free
Storage Length	-	-	0	0	-	0	-	-	405	405	-	550
Veh in Median Storage, #	-	2	-	-	2	-	-	0	-	-	0	-
Grade, %	-	0	-	-	0	-	-	0	-	-	0	-
Peak Hour Factor	95	95	95	95	95	95	95	95	95	95	95	95
Heavy Vehicles, %	2	2	2	2	2	2	2	2	2	2	2	2
Mvmt Flow	0	0	13	44	0	46	0	1859	75	38	1396	118

Major/Minor	Minor2		Minor1		Major1			Major2				
Conflicting Flow All	-	-	698	2493	-	930	-	0	0	1934	0	0
Stage 1	-	-	-	1859	-	-	-	-	-	-	-	-
Stage 2	-	-	-	634	-	-	-	-	-	-	-	-
Critical Hdwy	-	-	7.14	6.44	-	7.14	-	-	-	5.34	-	-
Critical Hdwy Stg 1	-	-	-	7.34	-	-	-	-	-	-	-	-
Critical Hdwy Stg 2	-	-	-	6.74	-	-	-	-	-	-	-	-
Follow-up Hdwy	-	-	3.92	3.82	-	3.92	-	-	-	3.12	-	-
Pot Cap-1 Maneuver	0	0	328	~ 31	0	231	0	-	-	135	-	0
Stage 1	0	0	-	49	0	-	0	-	-	-	-	0
Stage 2	0	0	-	395	0	-	0	-	-	-	-	0
Platoon blocked, %								-	-	-		
Mov Cap-1 Maneuver	-	-	328	~ 23	-	231	-	-	-	135	-	-
Mov Cap-2 Maneuver	-	-	-	46	-	-	-	-	-	-	-	-
Stage 1	-	-	-	49	-	-	-	-	-	-	-	-
Stage 2	-	-	-	273	-	-	-	-	-	-	-	-

Approach	EB		WB		NB		SB	
HCM Control Delay, s	16.4		138.9		0		1.1	
HCM LOS	C		F					

Minor Lane/Major Mvmt	NBT	NBR	EBLn1	WBLn1	WBLn2	SBL	SBT
Capacity (veh/h)	-	-	328	46	231	135	-
HCM Lane V/C Ratio	-	-	0.039	0.961	0.201	0.281	-
HCM Control Delay (s)	-	-	16.4	258.7	24.5	41.8	-
HCM Lane LOS	-	-	C	F	C	E	-
HCM 95th %tile Q(veh)	-	-	0.1	4	0.7	1.1	-

Notes
 -: Volume exceeds capacity \$: Delay exceeds 300s +: Computation Not Defined *: All major volume in platoon

HCM 6th TWSC
3: Pinehurst Dr & Spring Hill Dr

11/18/2022

Intersection												
Int Delay, s/veh	5.3											
Movement	EBL	EBT	EBR	WBL	WBT	WBR	NBL	NBT	NBR	SBL	SBT	SBR
Lane Configurations		↑↑		↑	↑↑				↑		↑↓	
Traffic Vol, veh/h	0	660	60	67	680	96	0	0	163	93	8	125
Future Vol, veh/h	0	660	60	67	680	96	0	0	163	93	8	125
Conflicting Peds, #/hr	0	0	0	0	0	0	0	0	0	0	0	0
Sign Control	Free	Free	Free	Free	Free	Free	Stop	Stop	Stop	Stop	Stop	Stop
RT Channelized	-	-	None	-	-	None	-	-	None	-	-	None
Storage Length	-	-	-	150	-	-	-	-	0	-	-	-
Veh in Median Storage, #	-	0	-	-	0	-	-	0	-	-	2	-
Grade, %	-	0	-	-	0	-	-	0	-	-	0	-
Peak Hour Factor	95	95	95	95	95	95	95	95	95	95	95	95
Heavy Vehicles, %	2	2	2	2	2	2	2	2	2	2	2	2
Mvmt Flow	0	695	63	71	716	101	0	0	172	98	8	132

Major/Minor	Major1			Major2			Minor1			Minor2		
Conflicting Flow All	-	0	0	758	0	0	-	-	379	1257	1667	409
Stage 1	-	-	-	-	-	-	-	-	-	909	909	-
Stage 2	-	-	-	-	-	-	-	-	-	348	758	-
Critical Hdwy	-	-	-	4.14	-	-	-	-	6.94	7.54	6.54	6.94
Critical Hdwy Stg 1	-	-	-	-	-	-	-	-	-	6.54	5.54	-
Critical Hdwy Stg 2	-	-	-	-	-	-	-	-	-	6.54	5.54	-
Follow-up Hdwy	-	-	-	2.22	-	-	-	-	3.32	3.52	4.02	3.32
Pot Cap-1 Maneuver	0	-	-	849	-	-	0	0	619	128	96	592
Stage 1	0	-	-	-	-	-	0	0	-	296	352	-
Stage 2	0	-	-	-	-	-	0	0	-	641	413	-
Platoon blocked, %		-	-	-	-	-						
Mov Cap-1 Maneuver	-	-	-	849	-	-	-	-	619	~ 87	88	592
Mov Cap-2 Maneuver	-	-	-	-	-	-	-	-	-	238	238	-
Stage 1	-	-	-	-	-	-	-	-	-	296	322	-
Stage 2	-	-	-	-	-	-	-	-	-	463	413	-

Approach	EB			WB			NB			SB		
HCM Control Delay, s	0			0.8			13			33.3		
HCM LOS							B			D		

Minor Lane/Major Mvmt	NBLn1	EBT	EBR	WBL	WBT	WBR	SBLn1
Capacity (veh/h)	619	-	-	849	-	-	356
HCM Lane V/C Ratio	0.277	-	-	0.083	-	-	0.668
HCM Control Delay (s)	13	-	-	9.6	-	-	33.3
HCM Lane LOS	B	-	-	A	-	-	D
HCM 95th %tile Q(veh)	1.1	-	-	0.3	-	-	4.6

Notes
 -: Volume exceeds capacity \$: Delay exceeds 300s +: Computation Not Defined *: All major volume in platoon

Timings

1: US 19 & Spring Hill Dr

01/03/2023



Lane Group	EBL	EBT	EBR	WBL	WBT	WBR	NBL	NBT	NBR	SBL	SBT	SBR
Lane Configurations	↖↖	↑↑	↗	↖↖	↑	↗	↖	↑↑↑	↗	↖↖	↑↑↑	↗
Traffic Volume (vph)	172	118	110	424	148	218	66	928	200	283	1060	46
Future Volume (vph)	172	118	110	424	148	218	66	928	200	283	1060	46
Confl. Peds. (#/hr)												
Confl. Bikes (#/hr)												
Peak Hour Factor	0.95	0.95	0.95	0.95	0.95	0.95	0.95	0.95	0.95	0.95	0.95	0.95
Growth Factor	100%	100%	100%	100%	100%	100%	100%	100%	100%	100%	100%	100%
Heavy Vehicles (%)	2%	2%	2%	2%	2%	2%	2%	2%	2%	2%	2%	2%
Bus Blockages (#/hr)	0	0	0	0	0	0	0	0	0	0	0	0
Parking (#/hr)												
Mid-Block Traffic (%)		0%			0%			0%			0%	
Shared Lane Traffic (%)												
Lane Group Flow (vph)	181	124	116	446	156	229	69	977	211	298	1116	48
Turn Type	Prot	NA	Perm	Prot	NA	Perm	Prot	NA	Perm	Prot	NA	Perm
Protected Phases	3	8		7	4		1	6		5	2	
Permitted Phases			8			4			6			2
Detector Phase	3	8	8	7	4	4	1	6	6	5	2	2
Switch Phase												
Minimum Initial (s)	5.0	10.0	10.0	5.0	10.0	10.0	5.0	20.0	20.0	5.0	20.0	20.0
Minimum Split (s)	14.0	18.0	18.0	14.0	18.0	18.0	14.0	28.2	28.2	14.0	28.2	28.2
Total Split (s)	25.0	25.0	25.0	30.0	30.0	30.0	20.0	55.0	55.0	30.0	65.0	65.0
Total Split (%)	17.9%	17.9%	17.9%	21.4%	21.4%	21.4%	14.3%	39.3%	39.3%	21.4%	46.4%	46.4%
Yellow Time (s)	4.5	4.5	4.5	4.5	4.5	4.5	5.6	5.6	5.6	5.6	5.6	5.6
All-Red Time (s)	3.5	3.5	3.5	3.5	3.5	3.5	2.6	2.6	2.6	2.6	2.6	2.6
Lost Time Adjust (s)	0.0	0.0	0.0	0.0	0.0	0.0	0.0	0.0	0.0	0.0	0.0	0.0
Total Lost Time (s)	8.0	8.0	8.0	8.0	8.0	8.0	8.2	8.2	8.2	8.2	8.2	8.2
Lead/Lag	Lead	Lag	Lag	Lead	Lag	Lag	Lead	Lag	Lag	Lead	Lag	Lag
Lead-Lag Optimize?	Yes	Yes	Yes	Yes	Yes	Yes	Yes	Yes	Yes	Yes	Yes	Yes
Recall Mode	None	None	None	None	None	None	None	C-Max	C-Max	None	C-Max	C-Max
Act Effect Green (s)	12.7	11.8	11.8	21.2	20.2	20.2	10.2	57.3	57.3	17.4	67.5	67.5
Actuated g/C Ratio	0.09	0.08	0.08	0.15	0.14	0.14	0.07	0.41	0.41	0.12	0.48	0.48
v/c Ratio	0.58	0.42	0.34	0.86	0.58	0.54	0.54	0.47	0.27	0.70	0.46	0.06
Control Delay	68.5	64.7	2.6	74.8	65.1	11.0	77.6	32.2	3.7	67.6	26.3	0.1
Queue Delay	0.0	0.0	0.0	0.0	0.0	0.0	0.0	0.0	0.0	0.0	0.0	0.0
Total Delay	68.5	64.7	2.6	74.8	65.1	11.0	77.6	32.2	3.7	67.6	26.3	0.1
LOS	E	E	A	E	E	B	E	C	A	E	C	A
Approach Delay		49.2			55.4			29.9			33.9	
Approach LOS		D			E			C			C	
Queue Length 50th (ft)	82	57	0	205	135	0	61	234	0	136	252	0
Queue Length 95th (ft)	120	88	0	#282	207	74	113	316	44	180	327	0
Internal Link Dist (ft)		920			220			920			1100	
Turn Bay Length (ft)	400		150				500		550	350		545
Base Capacity (vph)	416	429	395	539	294	445	151	2081	783	534	2451	848
Starvation Cap Reductn	0	0	0	0	0	0	0	0	0	0	0	0
Spillback Cap Reductn	0	0	0	0	0	0	0	0	0	0	0	0
Storage Cap Reductn	0	0	0	0	0	0	0	0	0	0	0	0
Reduced v/c Ratio	0.44	0.29	0.29	0.83	0.53	0.51	0.46	0.47	0.27	0.56	0.46	0.06

Intersection Summary

Timings

1: US 19 & Spring Hill Dr

01/03/2023

Cycle Length: 140

Actuated Cycle Length: 140

Offset: 55 (39%), Referenced to phase 2:SBT and 6:NBT, Start of Green

Natural Cycle: 80

Control Type: Actuated-Coordinated

Maximum v/c Ratio: 0.86

Intersection Signal Delay: 38.8

Intersection LOS: D

Intersection Capacity Utilization 73.4%

ICU Level of Service D

Analysis Period (min) 15

95th percentile volume exceeds capacity, queue may be longer.

Queue shown is maximum after two cycles.

Splits and Phases: 1: US 19 & Spring Hill Dr



HCM 6th TWSC
2: US 19 & Osowaw Blvd/Driveway B

01/03/2023

Intersection												
Int Delay, s/veh	1.7											
Movement	EBL	EBT	EBR	WBL	WBT	WBR	NBL	NBT	NBR	SBL	SBT	SBR
Lane Configurations			↗	↘		↗		↑↑↑		↗	↑↑↑	↗
Traffic Vol, veh/h	0	0	8	49	0	40	0	1217	64	46	1336	101
Future Vol, veh/h	0	0	8	49	0	40	0	1217	64	46	1336	101
Conflicting Peds, #/hr	0	0	0	0	0	0	0	0	0	0	0	0
Sign Control	Stop	Stop	Stop	Stop	Stop	Stop	Free	Free	Free	Free	Free	Free
RT Channelized	-	-	Yield	-	-	None	-	-	None	-	-	Free
Storage Length	-	-	0	0	-	0	-	-	405	405	-	550
Veh in Median Storage, #	-	2	-	-	2	-	-	0	-	-	0	-
Grade, %	-	0	-	-	0	-	-	0	-	-	0	-
Peak Hour Factor	95	95	95	95	95	95	95	95	95	95	95	95
Heavy Vehicles, %	2	2	2	2	2	2	2	2	2	2	2	2
Mvmt Flow	0	0	8	52	0	42	0	1281	67	48	1406	106

Major/Minor	Minor2		Minor1		Major1			Major2				
Conflicting Flow All	-	-	703	1939	-	641	-	0	0	1348	0	0
Stage 1	-	-	-	1281	-	-	-	-	-	-	-	-
Stage 2	-	-	-	658	-	-	-	-	-	-	-	-
Critical Hdwy	-	-	7.14	6.44	-	7.14	-	-	-	5.34	-	-
Critical Hdwy Stg 1	-	-	-	7.34	-	-	-	-	-	-	-	-
Critical Hdwy Stg 2	-	-	-	6.74	-	-	-	-	-	-	-	-
Follow-up Hdwy	-	-	3.92	3.82	-	3.92	-	-	-	3.12	-	-
Pot Cap-1 Maneuver	0	0	326	69	0	358	0	-	-	265	-	0
Stage 1	0	0	-	127	0	-	0	-	-	-	-	0
Stage 2	0	0	-	382	0	-	0	-	-	-	-	0
Platoon blocked, %								-	-	-		
Mov Cap-1 Maneuver	-	-	326	58	-	358	-	-	-	265	-	-
Mov Cap-2 Maneuver	-	-	-	117	-	-	-	-	-	-	-	-
Stage 1	-	-	-	127	-	-	-	-	-	-	-	-
Stage 2	-	-	-	305	-	-	-	-	-	-	-	-

Approach	EB		WB		NB		SB	
HCM Control Delay, s	16.3		39.4		0		0.7	
HCM LOS	C		E					

Minor Lane/Major Mvmt	NBT	NBR	EBLn1WBLn1WBLn2	SBL	SBT
Capacity (veh/h)	-	-	326 117 358	265	-
HCM Lane V/C Ratio	-	-	0.026 0.441 0.118	0.183	-
HCM Control Delay (s)	-	-	16.3 58.1 16.4	21.6	-
HCM Lane LOS	-	-	C F C	C	-
HCM 95th %tile Q(veh)	-	-	0.1 1.9 0.4	0.7	-

HCM 6th TWSC
3: Pinehurst Dr & Spring Hill Dr

01/03/2023

Intersection												
Int Delay, s/veh	5.1											
Movement	EBL	EBT	EBR	WBL	WBT	WBR	NBL	NBT	NBR	SBL	SBT	SBR
Lane Configurations		↑↑		↑	↑↑				↑		↑↓	
Traffic Vol, veh/h	0	442	75	82	671	102	0	0	64	80	8	164
Future Vol, veh/h	0	442	75	82	671	102	0	0	64	80	8	164
Conflicting Peds, #/hr	0	0	0	0	0	0	0	0	0	0	0	0
Sign Control	Free	Free	Free	Free	Free	Free	Stop	Stop	Stop	Stop	Stop	Stop
RT Channelized	-	-	None	-	-	None	-	-	None	-	-	None
Storage Length	-	-	-	150	-	-	-	-	0	-	-	-
Veh in Median Storage, #	-	0	-	-	0	-	-	0	-	-	2	-
Grade, %	-	0	-	-	0	-	-	0	-	-	0	-
Peak Hour Factor	95	95	95	95	95	95	95	95	95	95	95	95
Heavy Vehicles, %	2	2	2	2	2	2	2	2	2	2	2	2
Mvmt Flow	0	465	79	86	706	107	0	0	67	84	8	173

Major/Minor	Major1			Major2			Minor1			Minor2		
Conflicting Flow All	-	0	0	544	0	0	-	-	272	1165	1476	407
Stage 1	-	-	-	-	-	-	-	-	-	932	932	-
Stage 2	-	-	-	-	-	-	-	-	-	233	544	-
Critical Hdwy	-	-	-	4.14	-	-	-	-	6.94	7.54	6.54	6.94
Critical Hdwy Stg 1	-	-	-	-	-	-	-	-	-	6.54	5.54	-
Critical Hdwy Stg 2	-	-	-	-	-	-	-	-	-	6.54	5.54	-
Follow-up Hdwy	-	-	-	2.22	-	-	-	-	3.32	3.52	4.02	3.32
Pot Cap-1 Maneuver	0	-	-	1021	-	-	0	0	726	149	125	593
Stage 1	0	-	-	-	-	-	0	0	-	287	343	-
Stage 2	0	-	-	-	-	-	0	0	-	749	517	-
Platoon blocked, %	-	-	-	-	-	-	-	-	-	-	-	-
Mov Cap-1 Maneuver	-	-	-	1021	-	-	-	-	726	127	115	593
Mov Cap-2 Maneuver	-	-	-	-	-	-	-	-	-	260	261	-
Stage 1	-	-	-	-	-	-	-	-	-	287	314	-
Stage 2	-	-	-	-	-	-	-	-	-	679	517	-

Approach	EB			WB			NB			SB		
HCM Control Delay, s	0			0.8			10.5			28.5		
HCM LOS							B			D		

Minor Lane/Major Mvmt	NBLn1	EBT	EBR	WBL	WBT	WBR	SBLn1
Capacity (veh/h)	726	-	-	1021	-	-	410
HCM Lane V/C Ratio	0.093	-	-	0.085	-	-	0.647
HCM Control Delay (s)	10.5	-	-	8.9	-	-	28.5
HCM Lane LOS	B	-	-	A	-	-	D
HCM 95th %tile Q(veh)	0.3	-	-	0.3	-	-	4.4

Timings

1: US 19 & Spring Hill Dr

01/03/2023



Lane Group	EBL	EBT	EBR	WBL	WBT	WBR	NBL	NBT	NBR	SBL	SBT	SBR
Lane Configurations	↖↖	↗↗	↖	↖↖	↗	↖	↖	↗↗↗	↖	↖↖	↗↗↗	↖
Traffic Volume (vph)	212	191	55	342	141	290	83	1373	253	345	949	70
Future Volume (vph)	212	191	55	342	141	290	83	1373	253	345	949	70
Confl. Peds. (#/hr)												
Confl. Bikes (#/hr)												
Peak Hour Factor	0.95	0.95	0.95	0.95	0.95	0.95	0.95	0.95	0.95	0.95	0.95	0.95
Growth Factor	100%	100%	100%	100%	100%	100%	100%	100%	100%	100%	100%	100%
Heavy Vehicles (%)	2%	2%	2%	2%	2%	2%	2%	2%	2%	2%	2%	2%
Bus Blockages (#/hr)	0	0	0	0	0	0	0	0	0	0	0	0
Parking (#/hr)												
Mid-Block Traffic (%)		0%			0%			0%			0%	
Shared Lane Traffic (%)												
Lane Group Flow (vph)	223	201	58	360	148	305	87	1445	266	363	999	74
Turn Type	Prot	NA	Perm	Prot	NA	Perm	Prot	NA	Perm	Prot	NA	Perm
Protected Phases	3	8		7	4		1	6		5	2	
Permitted Phases			8			4			6			2
Detector Phase	3	8	8	7	4	4	1	6	6	5	2	2
Switch Phase												
Minimum Initial (s)	5.0	10.0	10.0	5.0	10.0	10.0	5.0	20.0	20.0	5.0	20.0	20.0
Minimum Split (s)	14.0	18.0	18.0	14.0	18.0	18.0	14.0	28.2	28.2	14.0	28.2	28.2
Total Split (s)	25.0	25.0	25.0	28.0	28.0	28.0	20.0	59.0	59.0	28.0	67.0	67.0
Total Split (%)	17.9%	17.9%	17.9%	20.0%	20.0%	20.0%	14.3%	42.1%	42.1%	20.0%	47.9%	47.9%
Yellow Time (s)	4.5	4.5	4.5	4.5	4.5	4.5	5.6	5.6	5.6	5.6	5.6	5.6
All-Red Time (s)	3.5	3.5	3.5	3.5	3.5	3.5	2.6	2.6	2.6	2.6	2.6	2.6
Lost Time Adjust (s)	0.0	0.0	0.0	0.0	0.0	0.0	0.0	0.0	0.0	0.0	0.0	0.0
Total Lost Time (s)	8.0	8.0	8.0	8.0	8.0	8.0	8.2	8.2	8.2	8.2	8.2	8.2
Lead/Lag	Lead	Lag	Lag	Lead	Lag	Lag	Lead	Lag	Lag	Lead	Lag	Lag
Lead-Lag Optimize?	Yes	Yes	Yes	Yes	Yes	Yes	Yes	Yes	Yes	Yes	Yes	Yes
Recall Mode	None	None	None	None	None	None	None	C-Max	C-Max	None	C-Max	C-Max
Act Effect Green (s)	14.1	13.8	13.8	18.5	18.2	18.2	10.7	56.8	56.8	18.5	64.6	64.6
Actuated g/C Ratio	0.10	0.10	0.10	0.13	0.13	0.13	0.08	0.41	0.41	0.13	0.46	0.46
v/c Ratio	0.64	0.58	0.19	0.79	0.61	0.83	0.64	0.70	0.33	0.80	0.43	0.09
Control Delay	69.1	66.7	1.4	72.3	68.7	42.6	84.1	37.8	4.5	72.8	26.8	0.2
Queue Delay	0.0	0.0	0.0	0.0	0.0	0.0	0.0	0.0	0.0	0.0	0.0	0.0
Total Delay	69.1	66.7	1.4	72.3	68.7	42.6	84.1	37.8	4.5	72.8	26.8	0.2
LOS	E	E	A	E	E	D	F	D	A	E	C	A
Approach Delay		59.9			60.5			35.1			37.1	
Approach LOS		E			E			D			D	
Queue Length 50th (ft)	102	94	0	164	129	110	77	407	0	165	226	0
Queue Length 95th (ft)	144	133	0	220	202	#250	138	487	59	222	280	0
Internal Link Dist (ft)		920			220			920			1100	
Turn Bay Length (ft)	400		150				500		550	350		545
Base Capacity (vph)	416	429	338	490	269	386	150	2063	800	486	2345	819
Starvation Cap Reductn	0	0	0	0	0	0	0	0	0	0	0	0
Spillback Cap Reductn	0	0	0	0	0	0	0	0	0	0	0	0
Storage Cap Reductn	0	0	0	0	0	0	0	0	0	0	0	0
Reduced v/c Ratio	0.54	0.47	0.17	0.73	0.55	0.79	0.58	0.70	0.33	0.75	0.43	0.09

Intersection Summary

Timings

1: US 19 & Spring Hill Dr

01/03/2023

Cycle Length: 140

Actuated Cycle Length: 140

Offset: 59 (42%), Referenced to phase 2:SBT and 6:NBT, Start of Green

Natural Cycle: 90

Control Type: Actuated-Coordinated

Maximum v/c Ratio: 0.83

Intersection Signal Delay: 42.9

Intersection LOS: D

Intersection Capacity Utilization 81.5%

ICU Level of Service D

Analysis Period (min) 15

95th percentile volume exceeds capacity, queue may be longer.

Queue shown is maximum after two cycles.

Splits and Phases: 1: US 19 & Spring Hill Dr

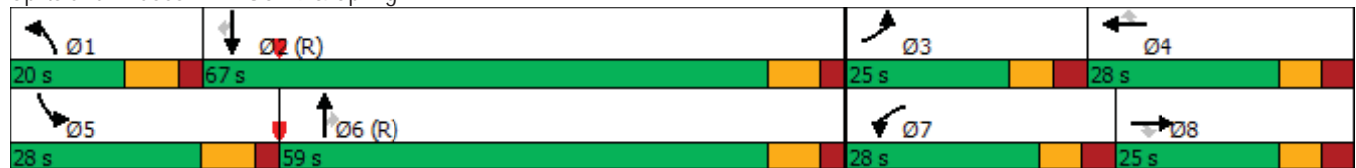

HCM 6th TWSC
2: US 19 & Osowaw Blvd/Driveway B

01/03/2023

Intersection												
Int Delay, s/veh	4.1											
Movement	EBL	EBT	EBR	WBL	WBT	WBR	NBL	NBT	NBR	SBL	SBT	SBR
Lane Configurations			↗	↘		↗		↑↑↑	↗	↘	↑↑↑	↗
Traffic Vol, veh/h	0	0	12	42	0	44	0	1766	71	36	1326	112
Future Vol, veh/h	0	0	12	42	0	44	0	1766	71	36	1326	112
Conflicting Peds, #/hr	0	0	0	0	0	0	0	0	0	0	0	0
Sign Control	Stop	Stop	Stop	Stop	Stop	Stop	Free	Free	Free	Free	Free	Free
RT Channelized	-	-	Yield	-	-	None	-	-	None	-	-	Free
Storage Length	-	-	0	0	-	0	-	-	405	405	-	550
Veh in Median Storage, #	-	2	-	-	2	-	-	0	-	-	0	-
Grade, %	-	0	-	-	0	-	-	0	-	-	0	-
Peak Hour Factor	95	95	95	95	95	95	95	95	95	95	95	95
Heavy Vehicles, %	2	2	2	2	2	2	2	2	2	2	2	2
Mvmt Flow	0	0	13	44	0	46	0	1859	75	38	1396	118

Major/Minor	Minor2		Minor1		Major1			Major2				
Conflicting Flow All	-	-	698	2493	-	930	-	0	0	1934	0	0
Stage 1	-	-	-	1859	-	-	-	-	-	-	-	-
Stage 2	-	-	-	634	-	-	-	-	-	-	-	-
Critical Hdwy	-	-	7.14	6.44	-	7.14	-	-	-	5.34	-	-
Critical Hdwy Stg 1	-	-	-	7.34	-	-	-	-	-	-	-	-
Critical Hdwy Stg 2	-	-	-	6.74	-	-	-	-	-	-	-	-
Follow-up Hdwy	-	-	3.92	3.82	-	3.92	-	-	-	3.12	-	-
Pot Cap-1 Maneuver	0	0	328	~31	0	231	0	-	-	135	-	0
Stage 1	0	0	-	49	0	-	0	-	-	-	-	0
Stage 2	0	0	-	395	0	-	0	-	-	-	-	0
Platoon blocked, %								-	-	-		
Mov Cap-1 Maneuver	-	-	328	~23	-	231	-	-	-	135	-	-
Mov Cap-2 Maneuver	-	-	-	46	-	-	-	-	-	-	-	-
Stage 1	-	-	-	49	-	-	-	-	-	-	-	-
Stage 2	-	-	-	273	-	-	-	-	-	-	-	-

Approach	EB		WB		NB		SB	
HCM Control Delay, s	16.4		138.9		0		1.1	
HCM LOS	C		F					

Minor Lane/Major Mvmt	NBT	NBR	EBLn1	WBLn1	WBLn2	SBL	SBT
Capacity (veh/h)	-	-	328	46	231	135	-
HCM Lane V/C Ratio	-	-	0.039	0.961	0.201	0.281	-
HCM Control Delay (s)	-	-	16.4	258.7	24.5	41.8	-
HCM Lane LOS	-	-	C	F	C	E	-
HCM 95th %tile Q(veh)	-	-	0.1	4	0.7	1.1	-

Notes
 -: Volume exceeds capacity \$: Delay exceeds 300s +: Computation Not Defined *: All major volume in platoon

HCM 6th TWSC
3: Pinehurst Dr & Spring Hill Dr

01/03/2023

Intersection												
Int Delay, s/veh	5.3											
Movement	EBL	EBT	EBR	WBL	WBT	WBR	NBL	NBT	NBR	SBL	SBT	SBR
Lane Configurations		↑↑		↑	↑↑				↑		↑↓	
Traffic Vol, veh/h	0	660	60	67	680	96	0	0	163	93	8	124
Future Vol, veh/h	0	660	60	67	680	96	0	0	163	93	8	124
Conflicting Peds, #/hr	0	0	0	0	0	0	0	0	0	0	0	0
Sign Control	Free	Free	Free	Free	Free	Free	Stop	Stop	Stop	Stop	Stop	Stop
RT Channelized	-	-	None	-	-	None	-	-	None	-	-	None
Storage Length	-	-	-	150	-	-	-	-	0	-	-	-
Veh in Median Storage, #	-	0	-	-	0	-	-	0	-	-	2	-
Grade, %	-	0	-	-	0	-	-	0	-	-	0	-
Peak Hour Factor	95	95	95	95	95	95	95	95	95	95	95	95
Heavy Vehicles, %	2	2	2	2	2	2	2	2	2	2	2	2
Mvmt Flow	0	695	63	71	716	101	0	0	172	98	8	131

Major/Minor	Major1			Major2			Minor1			Minor2		
Conflicting Flow All	-	0	0	758	0	0	-	-	379	1257	1667	409
Stage 1	-	-	-	-	-	-	-	-	-	909	909	-
Stage 2	-	-	-	-	-	-	-	-	-	348	758	-
Critical Hdwy	-	-	-	4.14	-	-	-	-	6.94	7.54	6.54	6.94
Critical Hdwy Stg 1	-	-	-	-	-	-	-	-	-	6.54	5.54	-
Critical Hdwy Stg 2	-	-	-	-	-	-	-	-	-	6.54	5.54	-
Follow-up Hdwy	-	-	-	2.22	-	-	-	-	3.32	3.52	4.02	3.32
Pot Cap-1 Maneuver	0	-	-	849	-	-	0	0	619	128	96	592
Stage 1	0	-	-	-	-	-	0	0	-	296	352	-
Stage 2	0	-	-	-	-	-	0	0	-	641	413	-
Platoon blocked, %		-	-	-	-	-						
Mov Cap-1 Maneuver	-	-	-	849	-	-	-	-	619	~ 87	88	592
Mov Cap-2 Maneuver	-	-	-	-	-	-	-	-	-	238	238	-
Stage 1	-	-	-	-	-	-	-	-	-	296	322	-
Stage 2	-	-	-	-	-	-	-	-	-	463	413	-

Approach	EB			WB			NB			SB		
HCM Control Delay, s	0			0.8			13			33.3		
HCM LOS							B			D		

Minor Lane/Major Mvmt	NBLn1	EBT	EBR	WBL	WBT	WBR	SBLn1
Capacity (veh/h)	619	-	-	849	-	-	355
HCM Lane V/C Ratio	0.277	-	-	0.083	-	-	0.667
HCM Control Delay (s)	13	-	-	9.6	-	-	33.3
HCM Lane LOS	B	-	-	A	-	-	D
HCM 95th %tile Q(veh)	1.1	-	-	0.3	-	-	4.6

Notes
 -: Volume exceeds capacity \$: Delay exceeds 300s +: Computation Not Defined *: All major volume in platoon

Timings

1: US 19 & Spring Hill Dr

01/03/2023



Lane Group	EBL	EBT	EBR	WBL	WBT	WBR	NBL	NBT	NBR	SBL	SBT	SBR
Lane Configurations	↖↖	↗↗	↖	↖↖	↗	↖	↖	↗↗↗	↖	↖↖	↗↗↗	↖
Traffic Volume (vph)	172	118	110	424	148	255	66	928	200	283	1060	46
Future Volume (vph)	172	118	110	424	148	255	66	928	200	283	1060	46
Confl. Peds. (#/hr)												
Confl. Bikes (#/hr)												
Peak Hour Factor	0.95	0.95	0.95	0.95	0.95	0.95	0.95	0.95	0.95	0.95	0.95	0.95
Growth Factor	100%	100%	100%	100%	100%	100%	100%	100%	100%	100%	100%	100%
Heavy Vehicles (%)	2%	2%	2%	2%	2%	2%	2%	2%	2%	2%	2%	2%
Bus Blockages (#/hr)	0	0	0	0	0	0	0	0	0	0	0	0
Parking (#/hr)												
Mid-Block Traffic (%)		0%			0%			0%			0%	
Shared Lane Traffic (%)												
Lane Group Flow (vph)	181	124	116	446	156	268	69	977	211	298	1116	48
Turn Type	Prot	NA	Perm	Prot	NA	Perm	Prot	NA	Perm	Prot	NA	Perm
Protected Phases	3	8		7	4		1	6		5	2	
Permitted Phases			8			4			6			2
Detector Phase	3	8	8	7	4	4	1	6	6	5	2	2
Switch Phase												
Minimum Initial (s)	5.0	10.0	10.0	5.0	10.0	10.0	5.0	20.0	20.0	5.0	20.0	20.0
Minimum Split (s)	14.0	18.0	18.0	14.0	18.0	18.0	14.0	28.2	28.2	14.0	28.2	28.2
Total Split (s)	25.0	25.0	25.0	30.0	30.0	30.0	20.0	55.0	55.0	30.0	65.0	65.0
Total Split (%)	17.9%	17.9%	17.9%	21.4%	21.4%	21.4%	14.3%	39.3%	39.3%	21.4%	46.4%	46.4%
Yellow Time (s)	4.5	4.5	4.5	4.5	4.5	4.5	5.6	5.6	5.6	5.6	5.6	5.6
All-Red Time (s)	3.5	3.5	3.5	3.5	3.5	3.5	2.6	2.6	2.6	2.6	2.6	2.6
Lost Time Adjust (s)	0.0	0.0	0.0	0.0	0.0	0.0	0.0	0.0	0.0	0.0	0.0	0.0
Total Lost Time (s)	8.0	8.0	8.0	8.0	8.0	8.0	8.2	8.2	8.2	8.2	8.2	8.2
Lead/Lag	Lead	Lag	Lag	Lead	Lag	Lag	Lead	Lag	Lag	Lead	Lag	Lag
Lead-Lag Optimize?	Yes	Yes	Yes	Yes	Yes	Yes	Yes	Yes	Yes	Yes	Yes	Yes
Recall Mode	None	None	None	None	None	None	None	C-Max	C-Max	None	C-Max	C-Max
Act Effect Green (s)	12.7	11.8	11.8	21.2	20.2	20.2	10.2	57.3	57.3	17.4	67.5	67.5
Actuated g/C Ratio	0.09	0.08	0.08	0.15	0.14	0.14	0.07	0.41	0.41	0.12	0.48	0.48
v/c Ratio	0.58	0.42	0.34	0.86	0.58	0.62	0.54	0.47	0.27	0.70	0.46	0.06
Control Delay	68.5	64.7	2.6	74.8	65.1	16.3	77.6	32.2	3.7	67.6	26.3	0.1
Queue Delay	0.0	0.0	0.0	0.0	0.0	0.0	0.0	0.0	0.0	0.0	0.0	0.0
Total Delay	68.5	64.7	2.6	74.8	65.1	16.3	77.6	32.2	3.7	67.6	26.3	0.1
LOS	E	E	A	E	E	B	E	C	A	E	C	A
Approach Delay		49.2			55.0			29.9			33.9	
Approach LOS		D			E			C			C	
Queue Length 50th (ft)	82	57	0	205	135	24	61	234	0	136	252	0
Queue Length 95th (ft)	120	88	0	#282	207	115	113	316	44	180	327	0
Internal Link Dist (ft)		920			220			920			1100	
Turn Bay Length (ft)	400		150				500		550	350		545
Base Capacity (vph)	416	429	395	539	294	451	151	2081	783	534	2451	848
Starvation Cap Reductn	0	0	0	0	0	0	0	0	0	0	0	0
Spillback Cap Reductn	0	0	0	0	0	0	0	0	0	0	0	0
Storage Cap Reductn	0	0	0	0	0	0	0	0	0	0	0	0
Reduced v/c Ratio	0.44	0.29	0.29	0.83	0.53	0.59	0.46	0.47	0.27	0.56	0.46	0.06

Intersection Summary

Timings

1: US 19 & Spring Hill Dr

01/03/2023

Cycle Length: 140

Actuated Cycle Length: 140

Offset: 55 (39%), Referenced to phase 2:SBT and 6:NBT, Start of Green

Natural Cycle: 80

Control Type: Actuated-Coordinated

Maximum v/c Ratio: 0.86

Intersection Signal Delay: 38.8

Intersection LOS: D

Intersection Capacity Utilization 73.4%

ICU Level of Service D

Analysis Period (min) 15

95th percentile volume exceeds capacity, queue may be longer.

Queue shown is maximum after two cycles.

Splits and Phases: 1: US 19 & Spring Hill Dr



HCM 6th TWSC
2: US 19 & Osowaw Blvd/Driveway B

01/03/2023

Intersection												
Int Delay, s/veh	1.7											
Movement	EBL	EBT	EBR	WBL	WBT	WBR	NBL	NBT	NBR	SBL	SBT	SBR
Lane Configurations			↗	↘		↗		↑↑↑	↗	↘	↑↑↑	↗
Traffic Vol, veh/h	0	0	8	49	0	40	0	1217	73	46	1336	101
Future Vol, veh/h	0	0	8	49	0	40	0	1217	73	46	1336	101
Conflicting Peds, #/hr	0	0	0	0	0	0	0	0	0	0	0	0
Sign Control	Stop	Stop	Stop	Stop	Stop	Stop	Free	Free	Free	Free	Free	Free
RT Channelized	-	-	Yield	-	-	None	-	-	None	-	-	Free
Storage Length	-	-	0	0	-	0	-	-	405	405	-	550
Veh in Median Storage, #	-	2	-	-	2	-	-	0	-	-	0	-
Grade, %	-	0	-	-	0	-	-	0	-	-	0	-
Peak Hour Factor	95	95	95	95	95	95	95	95	95	95	95	95
Heavy Vehicles, %	2	2	2	2	2	2	2	2	2	2	2	2
Mvmt Flow	0	0	8	52	0	42	0	1281	77	48	1406	106

Major/Minor	Minor2		Minor1		Major1			Major2				
Conflicting Flow All	-	-	703	1939	-	641	-	0	0	1358	0	0
Stage 1	-	-	-	1281	-	-	-	-	-	-	-	-
Stage 2	-	-	-	658	-	-	-	-	-	-	-	-
Critical Hdwy	-	-	7.14	6.44	-	7.14	-	-	-	5.34	-	-
Critical Hdwy Stg 1	-	-	-	7.34	-	-	-	-	-	-	-	-
Critical Hdwy Stg 2	-	-	-	6.74	-	-	-	-	-	-	-	-
Follow-up Hdwy	-	-	3.92	3.82	-	3.92	-	-	-	3.12	-	-
Pot Cap-1 Maneuver	0	0	326	69	0	358	0	-	-	262	-	0
Stage 1	0	0	-	127	0	-	0	-	-	-	-	0
Stage 2	0	0	-	382	0	-	0	-	-	-	-	0
Platoon blocked, %								-	-	-		
Mov Cap-1 Maneuver	-	-	326	58	-	358	-	-	-	262	-	-
Mov Cap-2 Maneuver	-	-	-	117	-	-	-	-	-	-	-	-
Stage 1	-	-	-	127	-	-	-	-	-	-	-	-
Stage 2	-	-	-	304	-	-	-	-	-	-	-	-

Approach	EB		WB		NB		SB	
HCM Control Delay, s	16.3		39.4		0		0.7	
HCM LOS	C		E					

Minor Lane/Major Mvmt	NBT	NBR	EBLn1WBLn1WBLn2	SBL	SBT
Capacity (veh/h)	-	-	326 117 358	262	-
HCM Lane V/C Ratio	-	-	0.026 0.441 0.118	0.185	-
HCM Control Delay (s)	-	-	16.3 58.1 16.4	21.8	-
HCM Lane LOS	-	-	C F C	C	-
HCM 95th %tile Q(veh)	-	-	0.1 1.9 0.4	0.7	-

HCM 6th TWSC
3: Pinehurst Dr & Spring Hill Dr

01/03/2023

Intersection												
Int Delay, s/veh	5.1											
Movement	EBL	EBT	EBR	WBL	WBT	WBR	NBL	NBT	NBR	SBL	SBT	SBR
Lane Configurations		↑↓		↑	↑↓				↑		↑↓	
Traffic Vol, veh/h	0	442	75	82	708	27	0	0	64	80	8	164
Future Vol, veh/h	0	442	75	82	708	27	0	0	64	80	8	164
Conflicting Peds, #/hr	0	0	0	0	0	0	0	0	0	0	0	0
Sign Control	Free	Free	Free	Free	Free	Free	Stop	Stop	Stop	Stop	Stop	Stop
RT Channelized	-	-	None	-	-	None	-	-	None	-	-	None
Storage Length	-	-	-	150	-	-	-	-	0	-	-	-
Veh in Median Storage, #	-	0	-	-	0	-	-	0	-	-	2	-
Grade, %	-	0	-	-	0	-	-	0	-	-	0	-
Peak Hour Factor	95	95	95	95	95	95	95	95	95	95	95	95
Heavy Vehicles, %	2	2	2	2	2	2	2	2	2	2	2	2
Mvmt Flow	0	465	79	86	745	28	0	0	67	84	8	173

Major/Minor	Major1			Major2			Minor1			Minor2		
Conflicting Flow All	-	0	0	544	0	0	-	-	272	1164	1475	387
Stage 1	-	-	-	-	-	-	-	-	-	931	931	-
Stage 2	-	-	-	-	-	-	-	-	-	233	544	-
Critical Hdwy	-	-	-	4.14	-	-	-	-	6.94	7.54	6.54	6.94
Critical Hdwy Stg 1	-	-	-	-	-	-	-	-	-	6.54	5.54	-
Critical Hdwy Stg 2	-	-	-	-	-	-	-	-	-	6.54	5.54	-
Follow-up Hdwy	-	-	-	2.22	-	-	-	-	3.32	3.52	4.02	3.32
Pot Cap-1 Maneuver	0	-	-	1021	-	-	0	0	726	150	125	611
Stage 1	0	-	-	-	-	-	0	0	-	287	344	-
Stage 2	0	-	-	-	-	-	0	0	-	749	517	-
Platoon blocked, %	-	-	-	-	-	-	-	-	-	-	-	-
Mov Cap-1 Maneuver	-	-	-	1021	-	-	-	-	726	127	115	611
Mov Cap-2 Maneuver	-	-	-	-	-	-	-	-	-	260	262	-
Stage 1	-	-	-	-	-	-	-	-	-	287	315	-
Stage 2	-	-	-	-	-	-	-	-	-	679	517	-

Approach	EB			WB			NB			SB		
HCM Control Delay, s	0			0.9			10.5			27.8		
HCM LOS							B			D		

Minor Lane/Major Mvmt	NBLn1	EBT	EBR	WBL	WBT	WBR	SBLn1
Capacity (veh/h)	726	-	-	1021	-	-	415
HCM Lane V/C Ratio	0.093	-	-	0.085	-	-	0.639
HCM Control Delay (s)	10.5	-	-	8.9	-	-	27.8
HCM Lane LOS	B	-	-	A	-	-	D
HCM 95th %tile Q(veh)	0.3	-	-	0.3	-	-	4.3

Timings

1: US 19 & Spring Hill Dr

01/03/2023



Lane Group	EBL	EBT	EBR	WBL	WBT	WBR	NBL	NBT	NBR	SBL	SBT	SBR
Lane Configurations	↖↖	↗↗	↖	↖↖	↗	↖	↖	↗↗↗	↖	↖↖	↗↗↗	↖
Traffic Volume (vph)	212	191	55	342	141	322	83	1373	253	345	949	70
Future Volume (vph)	212	191	55	342	141	322	83	1373	253	345	949	70
Confl. Peds. (#/hr)												
Confl. Bikes (#/hr)												
Peak Hour Factor	0.95	0.95	0.95	0.95	0.95	0.95	0.95	0.95	0.95	0.95	0.95	0.95
Growth Factor	100%	100%	100%	100%	100%	100%	100%	100%	100%	100%	100%	100%
Heavy Vehicles (%)	2%	2%	2%	2%	2%	2%	2%	2%	2%	2%	2%	2%
Bus Blockages (#/hr)	0	0	0	0	0	0	0	0	0	0	0	0
Parking (#/hr)												
Mid-Block Traffic (%)		0%			0%			0%			0%	
Shared Lane Traffic (%)												
Lane Group Flow (vph)	223	201	58	360	148	339	87	1445	266	363	999	74
Turn Type	Prot	NA	Perm	Prot	NA	Perm	Prot	NA	Perm	Prot	NA	Perm
Protected Phases	3	8		7	4		1	6		5	2	
Permitted Phases			8			4			6			2
Detector Phase	3	8	8	7	4	4	1	6	6	5	2	2
Switch Phase												
Minimum Initial (s)	5.0	10.0	10.0	5.0	10.0	10.0	5.0	20.0	20.0	5.0	20.0	20.0
Minimum Split (s)	14.0	18.0	18.0	14.0	18.0	18.0	14.0	28.2	28.2	14.0	28.2	28.2
Total Split (s)	25.0	25.0	25.0	28.0	28.0	28.0	20.0	59.0	59.0	28.0	67.0	67.0
Total Split (%)	17.9%	17.9%	17.9%	20.0%	20.0%	20.0%	14.3%	42.1%	42.1%	20.0%	47.9%	47.9%
Yellow Time (s)	4.5	4.5	4.5	4.5	4.5	4.5	5.6	5.6	5.6	5.6	5.6	5.6
All-Red Time (s)	3.5	3.5	3.5	3.5	3.5	3.5	2.6	2.6	2.6	2.6	2.6	2.6
Lost Time Adjust (s)	0.0	0.0	0.0	0.0	0.0	0.0	0.0	0.0	0.0	0.0	0.0	0.0
Total Lost Time (s)	8.0	8.0	8.0	8.0	8.0	8.0	8.2	8.2	8.2	8.2	8.2	8.2
Lead/Lag	Lead	Lag	Lag	Lead	Lag	Lag	Lead	Lag	Lag	Lead	Lag	Lag
Lead-Lag Optimize?	Yes	Yes	Yes	Yes	Yes	Yes	Yes	Yes	Yes	Yes	Yes	Yes
Recall Mode	None	None	None	None	None	None	None	C-Max	C-Max	None	C-Max	C-Max
Act Effect Green (s)	14.1	14.9	14.9	18.5	19.3	19.3	10.6	55.7	55.7	18.5	63.5	63.5
Actuated g/C Ratio	0.10	0.11	0.11	0.13	0.14	0.14	0.08	0.40	0.40	0.13	0.45	0.45
v/c Ratio	0.64	0.53	0.18	0.79	0.58	0.90	0.65	0.71	0.34	0.80	0.43	0.09
Control Delay	69.1	64.2	1.3	72.3	65.7	53.4	84.7	38.9	4.6	73.0	27.5	0.2
Queue Delay	0.0	0.0	0.0	0.0	0.0	0.0	0.0	0.0	0.0	0.0	0.0	0.0
Total Delay	69.1	64.2	1.3	72.3	65.7	53.4	84.7	38.9	4.6	73.0	27.5	0.2
LOS	E	E	A	E	E	D	F	D	A	E	C	A
Approach Delay		58.9			63.6			36.0			37.6	
Approach LOS		E			E			D			D	
Queue Length 50th (ft)	102	91	0	164	124	142	78	427	0	165	237	0
Queue Length 95th (ft)	144	133	0	220	202	#323	138	487	59	222	280	0
Internal Link Dist (ft)		920			220			920			1100	
Turn Bay Length (ft)	400		150				500		550	350		545
Base Capacity (vph)	416	430	338	490	275	391	149	2023	789	485	2307	808
Starvation Cap Reductn	0	0	0	0	0	0	0	0	0	0	0	0
Spillback Cap Reductn	0	0	0	0	0	0	0	0	0	0	0	0
Storage Cap Reductn	0	0	0	0	0	0	0	0	0	0	0	0
Reduced v/c Ratio	0.54	0.47	0.17	0.73	0.54	0.87	0.58	0.71	0.34	0.75	0.43	0.09

Intersection Summary

Timings

1: US 19 & Spring Hill Dr

01/03/2023

Cycle Length: 140

Actuated Cycle Length: 140

Offset: 59 (42%), Referenced to phase 2:SBT and 6:NBT, Start of Green

Natural Cycle: 90

Control Type: Actuated-Coordinated

Maximum v/c Ratio: 0.90

Intersection Signal Delay: 44.0

Intersection LOS: D

Intersection Capacity Utilization 81.5%

ICU Level of Service D

Analysis Period (min) 15

95th percentile volume exceeds capacity, queue may be longer.

Queue shown is maximum after two cycles.

Splits and Phases: 1: US 19 & Spring Hill Dr

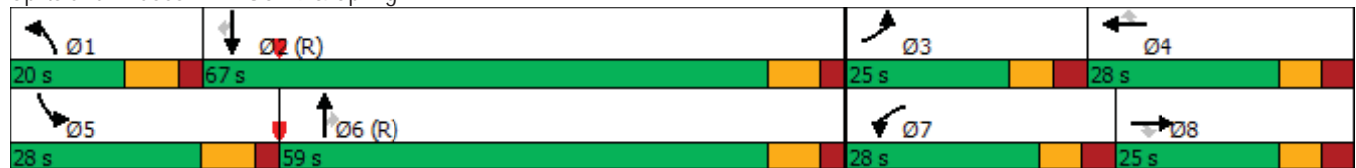

HCM 6th TWSC
2: US 19 & Osowaw Blvd/Driveway B

01/03/2023

Intersection												
Int Delay, s/veh	4.5											
Movement	EBL	EBT	EBR	WBL	WBT	WBR	NBL	NBT	NBR	SBL	SBT	SBR
Lane Configurations			↗	↘		↗		↑↑↑	↗	↘	↑↑↑	↗
Traffic Vol, veh/h	0	0	12	42	0	83	0	1766	71	36	1326	112
Future Vol, veh/h	0	0	12	42	0	83	0	1766	71	36	1326	112
Conflicting Peds, #/hr	0	0	0	0	0	0	0	0	0	0	0	0
Sign Control	Stop	Stop	Stop	Stop	Stop	Stop	Free	Free	Free	Free	Free	Free
RT Channelized	-	-	Yield	-	-	None	-	-	None	-	-	Free
Storage Length	-	-	0	0	-	0	-	-	405	405	-	550
Veh in Median Storage, #	-	2	-	-	2	-	-	0	-	-	0	-
Grade, %	-	0	-	-	0	-	-	0	-	-	0	-
Peak Hour Factor	95	95	95	95	95	95	95	95	95	95	95	95
Heavy Vehicles, %	2	2	2	2	2	2	2	2	2	2	2	2
Mvmt Flow	0	0	13	44	0	87	0	1859	75	38	1396	118

Major/Minor	Minor2		Minor1		Major1			Major2				
Conflicting Flow All	-	-	698	2493	-	930	-	0	0	1934	0	0
Stage 1	-	-	-	1859	-	-	-	-	-	-	-	-
Stage 2	-	-	-	634	-	-	-	-	-	-	-	-
Critical Hdwy	-	-	7.14	6.44	-	7.14	-	-	-	5.34	-	-
Critical Hdwy Stg 1	-	-	-	7.34	-	-	-	-	-	-	-	-
Critical Hdwy Stg 2	-	-	-	6.74	-	-	-	-	-	-	-	-
Follow-up Hdwy	-	-	3.92	3.82	-	3.92	-	-	-	3.12	-	-
Pot Cap-1 Maneuver	0	0	328	~ 31	0	231	0	-	-	135	-	0
Stage 1	0	0	-	49	0	-	0	-	-	-	-	0
Stage 2	0	0	-	395	0	-	0	-	-	-	-	0
Platoon blocked, %								-	-	-		
Mov Cap-1 Maneuver	-	-	328	~ 23	-	231	-	-	-	135	-	-
Mov Cap-2 Maneuver	-	-	-	46	-	-	-	-	-	-	-	-
Stage 1	-	-	-	49	-	-	-	-	-	-	-	-
Stage 2	-	-	-	273	-	-	-	-	-	-	-	-

Approach	EB		WB		NB		SB	
HCM Control Delay, s	16.4		106.7		0		1.1	
HCM LOS	C		F					

Minor Lane/Major Mvmt	NBT	NBR	EBLn1	WBLn1	WBLn2	SBL	SBT
Capacity (veh/h)	-	-	328	46	231	135	-
HCM Lane V/C Ratio	-	-	0.039	0.961	0.378	0.281	-
HCM Control Delay (s)	-	-	16.4	258.7	29.8	41.8	-
HCM Lane LOS	-	-	C	F	D	E	-
HCM 95th %tile Q(veh)	-	-	0.1	4	1.7	1.1	-

Notes
 -: Volume exceeds capacity \$: Delay exceeds 300s +: Computation Not Defined *: All major volume in platoon

HCM 6th TWSC
3: Pinehurst Dr & Spring Hill Dr

01/03/2023

Intersection												
Int Delay, s/veh	5.3											
Movement	EBL	EBT	EBR	WBL	WBT	WBR	NBL	NBT	NBR	SBL	SBT	SBR
Lane Configurations		↑↑		↑	↑↑				↑		↑↓	
Traffic Vol, veh/h	0	660	60	67	712	32	0	0	163	93	8	124
Future Vol, veh/h	0	660	60	67	712	32	0	0	163	93	8	124
Conflicting Peds, #/hr	0	0	0	0	0	0	0	0	0	0	0	0
Sign Control	Free	Free	Free	Free	Free	Free	Stop	Stop	Stop	Stop	Stop	Stop
RT Channelized	-	-	None	-	-	None	-	-	None	-	-	None
Storage Length	-	-	-	150	-	-	-	-	0	-	-	-
Veh in Median Storage, #	-	0	-	-	0	-	-	0	-	-	2	-
Grade, %	-	0	-	-	0	-	-	0	-	-	0	-
Peak Hour Factor	95	95	95	95	95	95	95	95	95	95	95	95
Heavy Vehicles, %	2	2	2	2	2	2	2	2	2	2	2	2
Mvmt Flow	0	695	63	71	749	34	0	0	172	98	8	131

Major/Minor	Major1			Major2			Minor1			Minor2		
Conflicting Flow All	-	0	0	758	0	0	-	-	379	1256	1666	392
Stage 1	-	-	-	-	-	-	-	-	-	908	908	-
Stage 2	-	-	-	-	-	-	-	-	-	348	758	-
Critical Hdwy	-	-	-	4.14	-	-	-	-	6.94	7.54	6.54	6.94
Critical Hdwy Stg 1	-	-	-	-	-	-	-	-	-	6.54	5.54	-
Critical Hdwy Stg 2	-	-	-	-	-	-	-	-	-	6.54	5.54	-
Follow-up Hdwy	-	-	-	2.22	-	-	-	-	3.32	3.52	4.02	3.32
Pot Cap-1 Maneuver	0	-	-	849	-	-	0	0	619	128	96	607
Stage 1	0	-	-	-	-	-	0	0	-	296	352	-
Stage 2	0	-	-	-	-	-	0	0	-	641	413	-
Platoon blocked, %		-	-	-	-	-						
Mov Cap-1 Maneuver	-	-	-	849	-	-	-	-	619	~ 87	88	607
Mov Cap-2 Maneuver	-	-	-	-	-	-	-	-	-	238	238	-
Stage 1	-	-	-	-	-	-	-	-	-	296	322	-
Stage 2	-	-	-	-	-	-	-	-	-	463	413	-

Approach	EB			WB			NB			SB		
HCM Control Delay, s	0			0.8			13			32.7		
HCM LOS							B			D		

Minor Lane/Major Mvmt	NBLn1	EBT	EBR	WBL	WBT	WBR	SBLn1
Capacity (veh/h)	619	-	-	849	-	-	358
HCM Lane V/C Ratio	0.277	-	-	0.083	-	-	0.662
HCM Control Delay (s)	13	-	-	9.6	-	-	32.7
HCM Lane LOS	B	-	-	A	-	-	D
HCM 95th %tile Q(veh)	1.1	-	-	0.3	-	-	4.5

Notes
 -: Volume exceeds capacity \$: Delay exceeds 300s +: Computation Not Defined *: All major volume in platoon