



Black Jack Ridge

Mixed Use Development

H-25-40

Hernando County
Planning & Zoning Commission
March 9, 2026

Location Map of Property

- Owned by Jack Melton Family, Inc.
- 203.89 acres
- Parcel Keys:
 - 840923: 179.16 acres
 - 841138: 21.65 acres
 - 1760151: 3.08 acres



Location Map of Property

- Owned by Jack Melton Family, Inc.
- 203.89 acres
- Parcel Keys:
 - 840923: 179.16 acres
 - 841138: 21.65 acres
 - 1760151: 3.08 acres

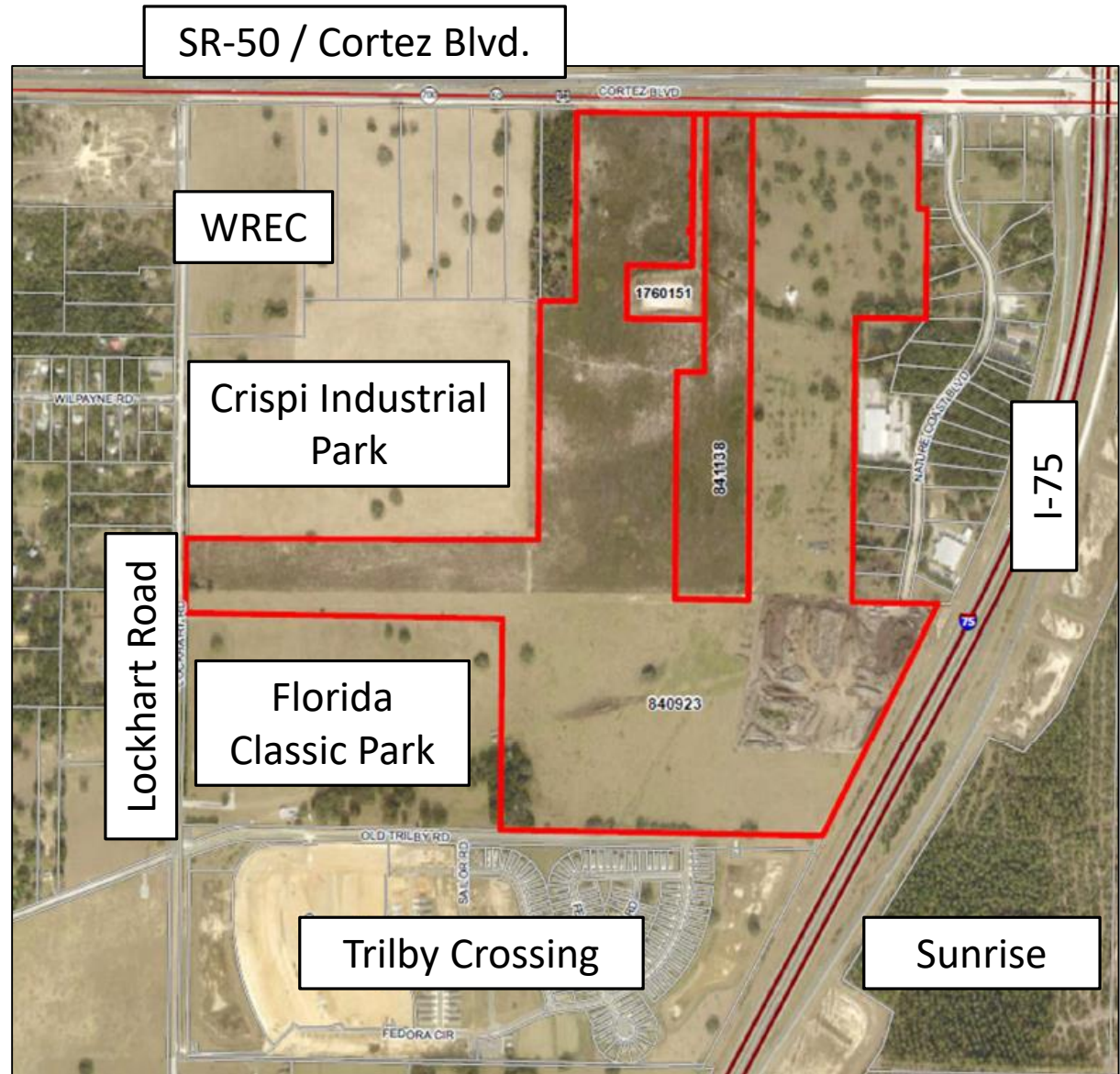

Request

- AG, PDP-HC, PDP-GC, and C-2 to a Combined Planned Development District (CPDP)
- Maximum 978 units
- Maximum 200,000 SF of commercial PDP(HC)
- Maximum of 100,000 SF of commercial PDP(GC)

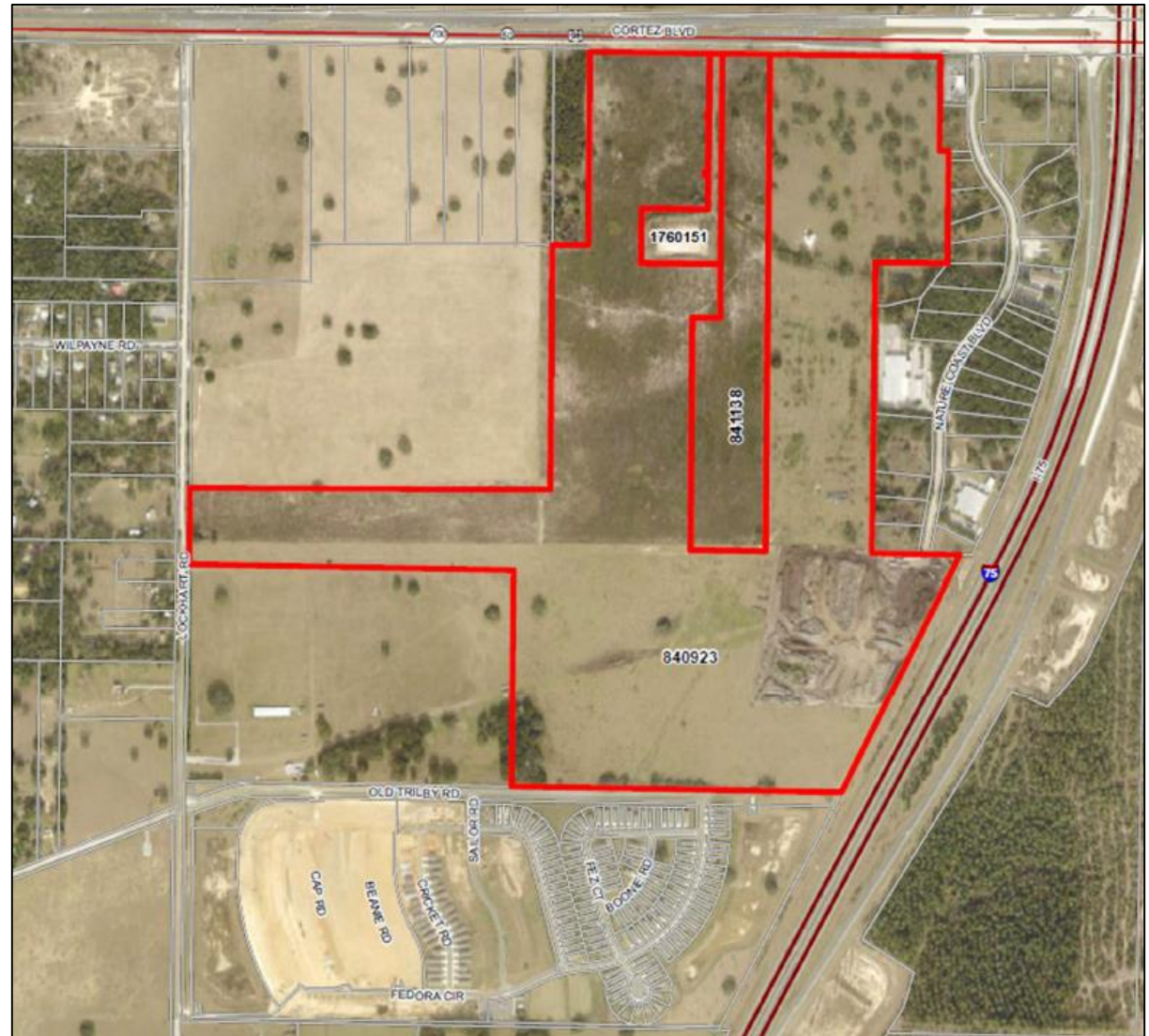

FLU: I-75/SR-50 PDD

Zoning: AG; PDP (GHC); PDP (HC); C-2

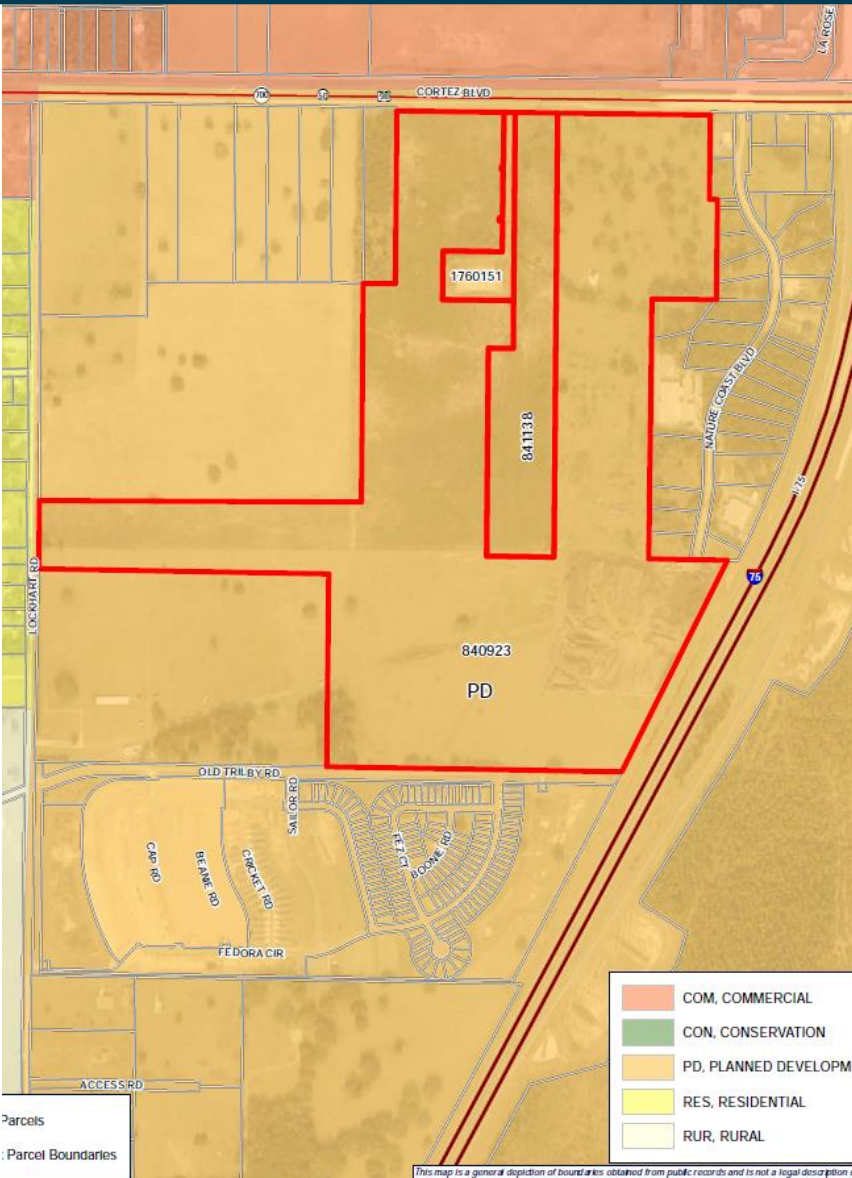

M A P S

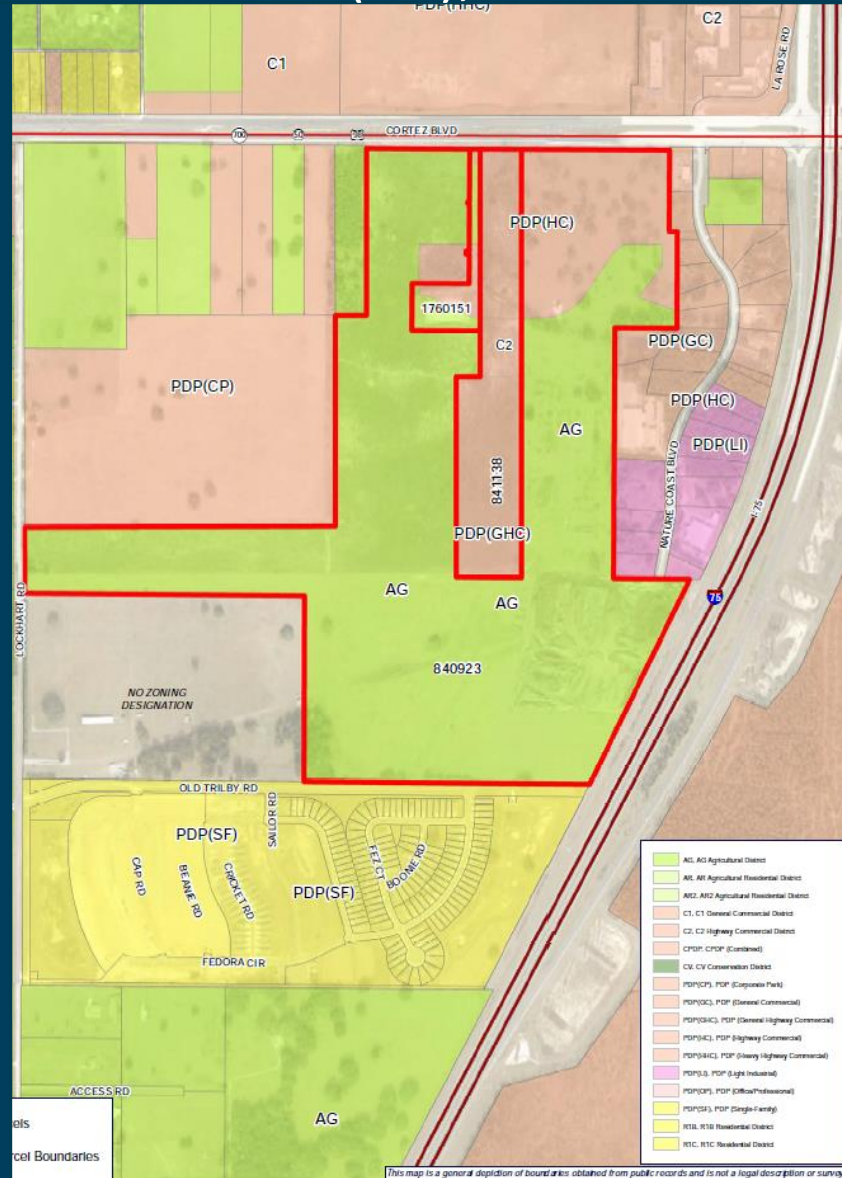

Comprehensive Plan

I-75/SR-50 Planned Development District

- All new developments must undergo the Planned Development Project (PDP) rezoning process
- Recognized significant potential for future development of multiple land use types
- Supported by public infrastructure
- Multi-modal transportation required
- Planning for future transportation network with FDOT
- Impact fee surcharge area

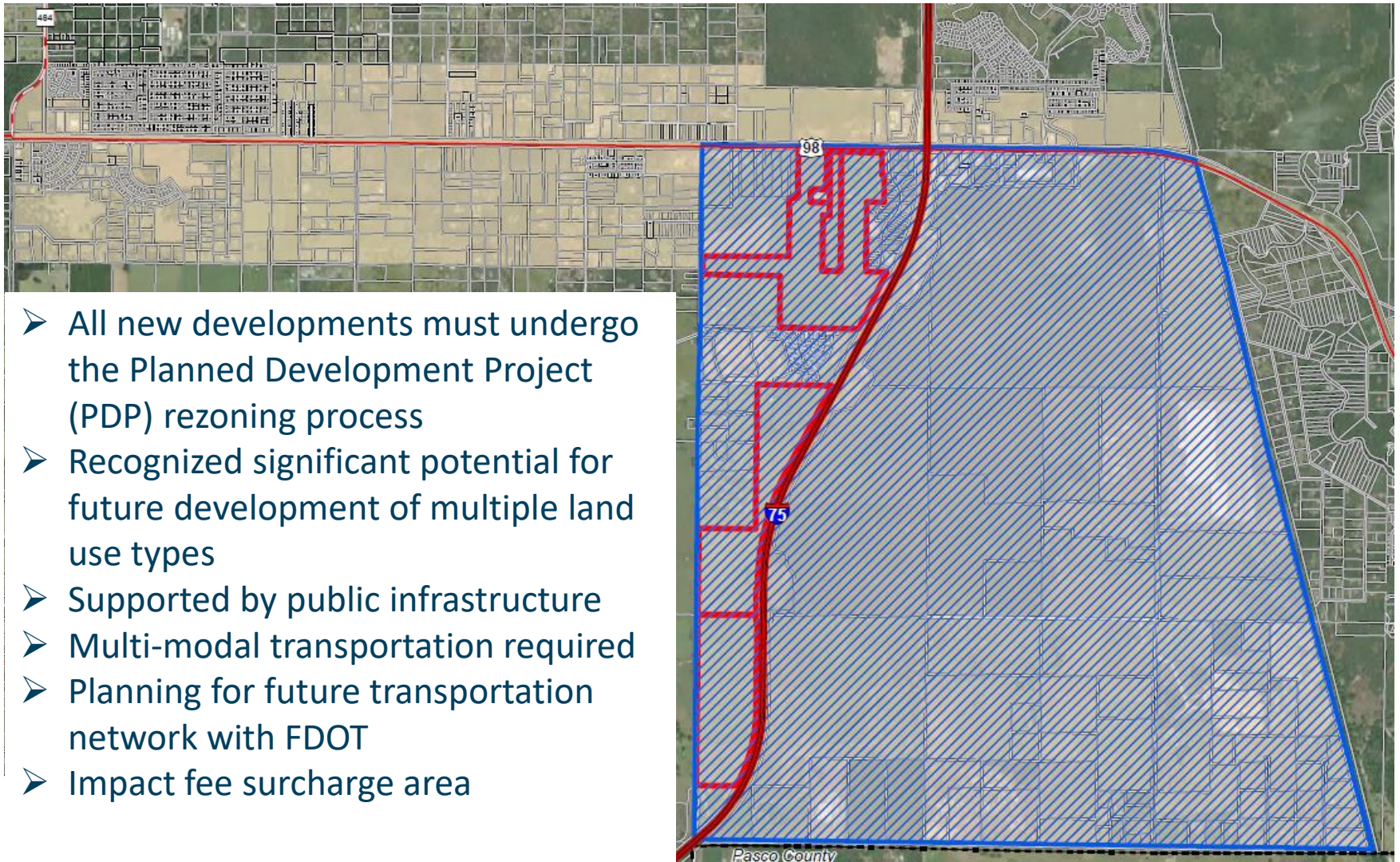

Comprehensive Plan I-75/SR-50 Planned Development District – Surcharge Area

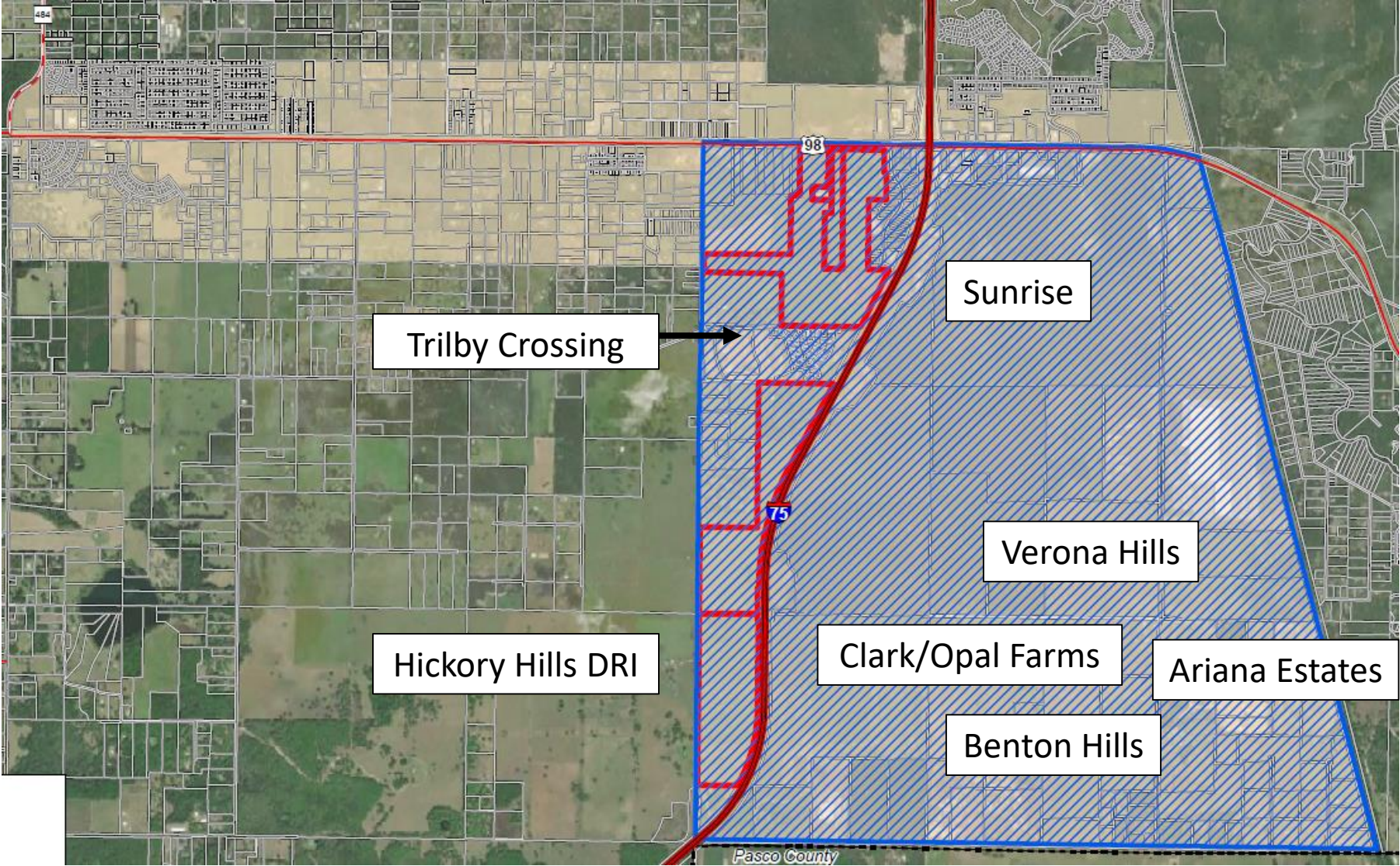

I-75/SR-50 PDD Future Land Use

- Designation applied to unique and specialized areas within the County
 - I-75/SR-50
 - Airport
 - World Woods
 - Hickory Hills
 - Brooksville Regional Medical Center
 - Quarry Preserve
 - South Brooksville
 - Spring Center
- I-75/SR-50 Area Plan developed in 2007
- Growth directed here
- Infrastructure Improvements
 - Impact Fee Surcharge

COMPREHENSIVE PLAN CONSISTENCY/NEEDS REPORT
FOR THE
I-75/SR50 PLANNED DEVELOPMENT DISTRICT
AREA PLAN

SEPTEMBER 2007



Comprehensive Plan

I-75/SR-50 Planned Development District

GOAL 1.05 – Planned Development District

Planned Development District (PDD) is a Future Land Use Map Category that provides coordinated planning of new developments and redevelopments with proposed multiple uses or types that have specialized or unique characteristics, or would benefit from a relatively high level of planning control and coordination. PDDs envision a mixture of land uses with the locations of each land use determined through a master planning process.

. . . The densities and intensities assigned to each individual PDD are addressed in the Master Plan of the development. . .

Comprehensive Plan

I-75/SR-50 Planned Development District

Objective 1.05A

The I-75/SR-50 Planned Development District (I-75/SR-50 PDD) is hereby established for the purpose of implementing planning tools to **maximize the potential economic value of the I-75 corridor** through coordination of **multiple land uses, roadway network configuration, new and upgraded public infrastructure and consistency of design. . .**

Strategy 1.05A(1)

The I-75/SR-50 Planned Development District mapped area is **characterized by significant potential for future development of multiple land use types**. The I-75/SR-50 PDD shall seek to create, to the maximum extent practical, **a largely self-contained internally functional concentration of commercial, industrial, and mixed residential land uses supported by public infrastructure. . .**

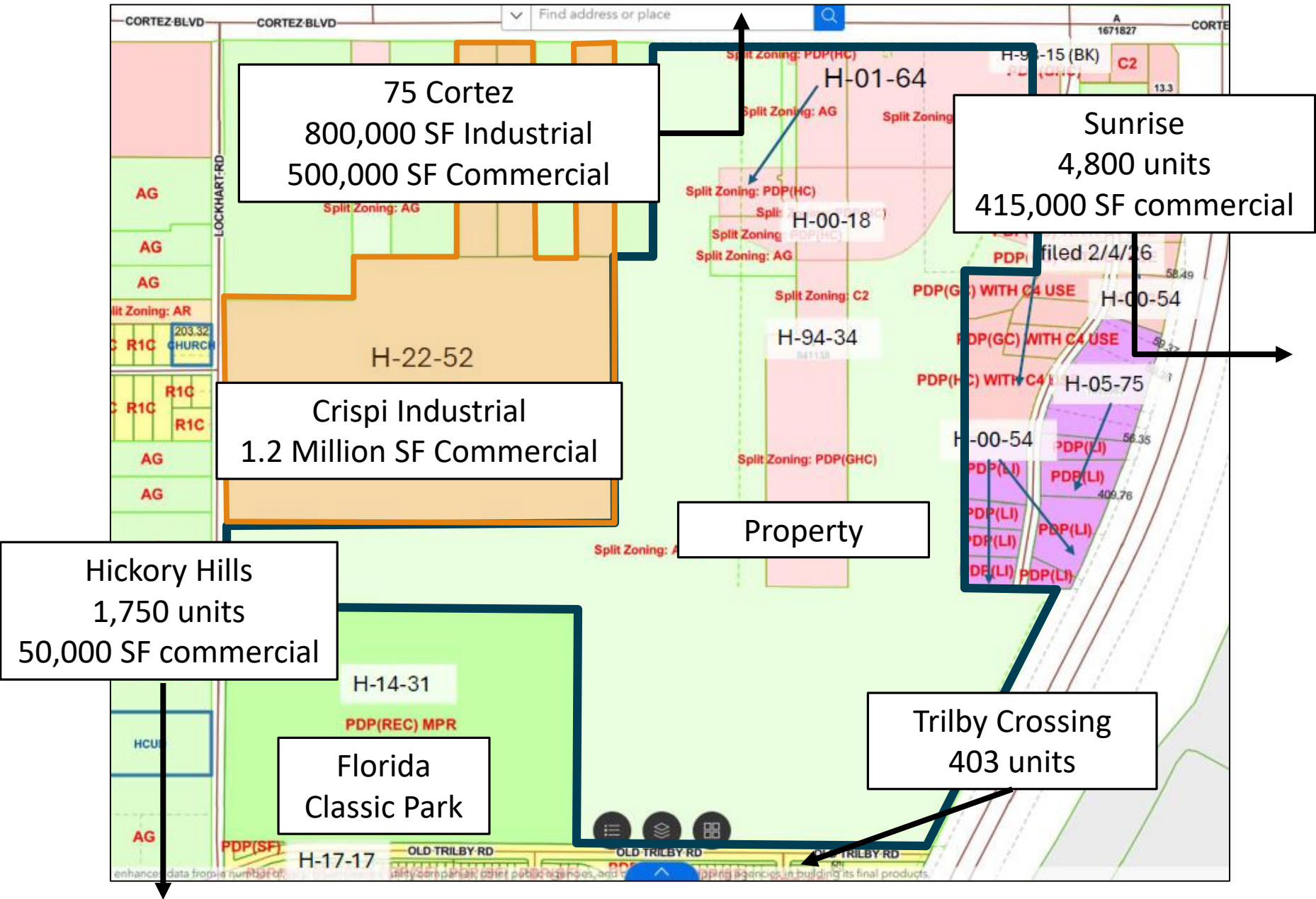

Master Plan

Transition of land uses, from north to south:

- Highway Commercial
 - Max 200,000 SF
- Commercial Mixed Use
 - Max 100,000 SF
 - Or 320 multifamily units
 - apartments, townhomes, villas
- Residential Mixed Use
 - Townhomes, villas, single family detached
- Single Family Area
 - Single family detached
 - Min. 50' wide lots

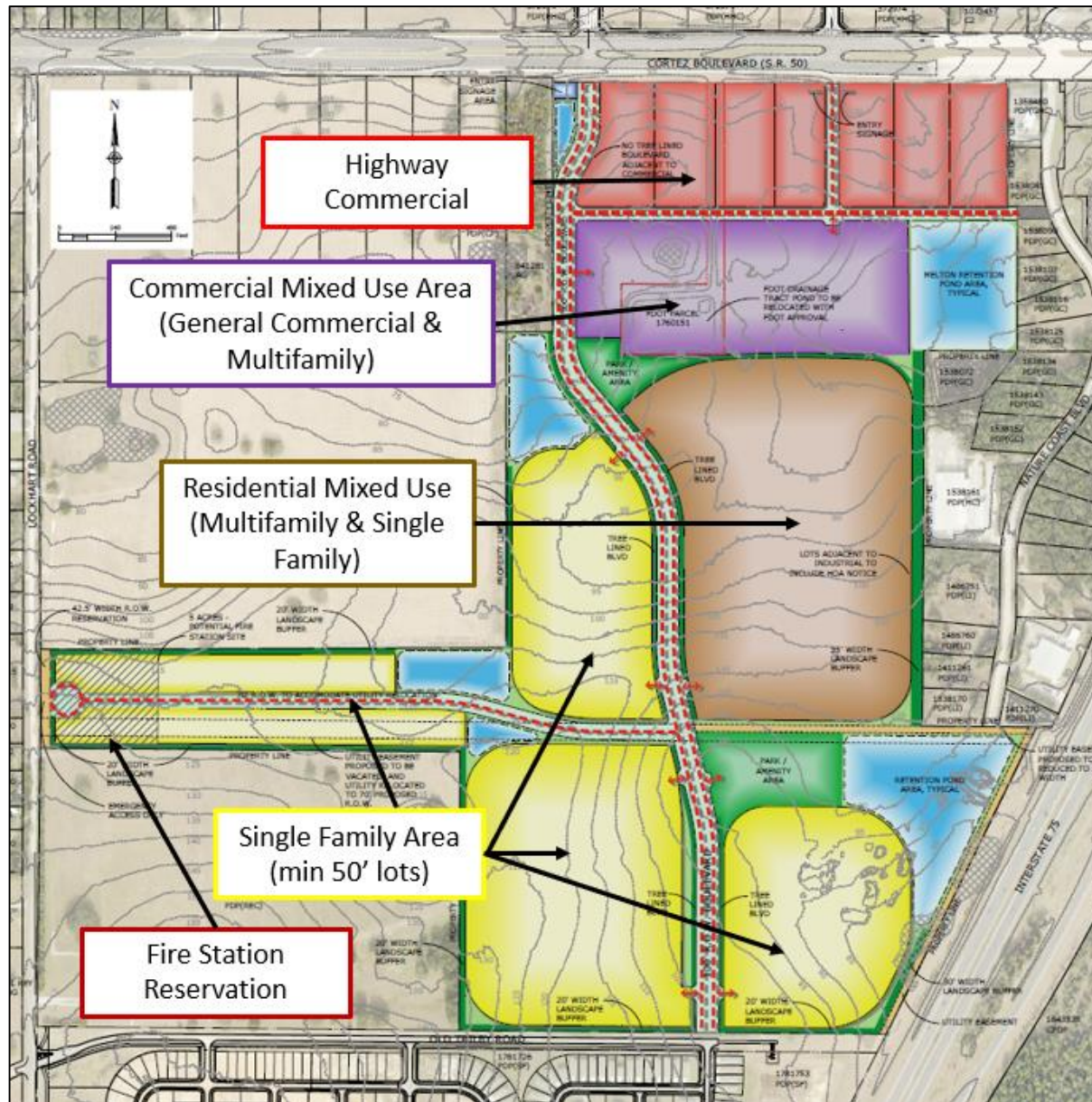

Request Details

Transition of land uses, from north to south:

- Highway Commercial
 - Max 200,000 SF
- Commercial Mixed Use
 - Max 100,000 SF
 - Or 320 multifamily units
 - apartments, townhomes, villas
- Residential Mixed Use
 - Townhomes, villas, single family detached
- Single Family Area
 - Single family detached
 - Min. 50' wide lots

LAND USE TABLE			
LAND USE	ACRES	UNITS	DENSITY
COMMERCIAL AREA PDP(HC)	20		200,000 SQ. FT.
COMMERCIAL MIXED USE PDP(GC), PDP(MF)	19	320*	100,000 SQ. FT.
SINGLE FAMILY PDP(SF)	72	288*	
RESIDENTIAL MIXED USE PDP(MF) & PDP(SF)	37	370*	
DRAINAGE, RECREATION, BUFFERS, OPEN SPACE	37.81		
ROADS	18		
TOTAL:	+/- 203.89	978	

Permitted Uses

Commercial Mixed Use Area (Purple)

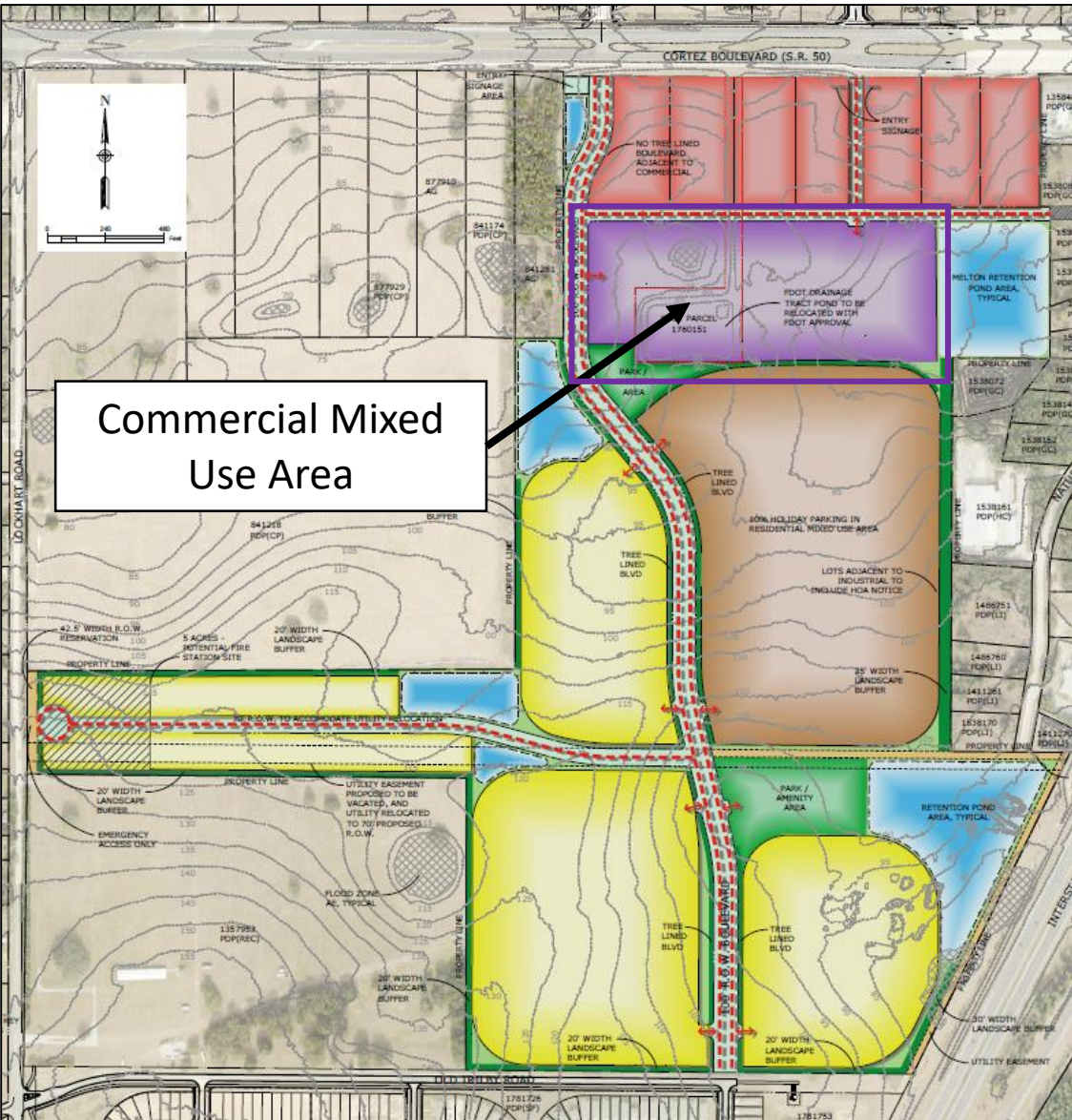

Commercial Mixed Use Area

Proposed Uses:

- 1) All C-1 Highway Commercial District Permitted Uses
- 2) Hospital and/or Urgent Care/Stand-Alone Emergency Room
- 3) Educational Facilities
- 4) Light Wholesale and Storage
- 5) Microbreweries
-

Commercial Mixed Use Area (Purple)



Commercial Mixed Use Area

Proposed Uses (continued):

- 6) Microbreweries
- 7) Public/Private Recreation including Virtual Golf and/or Pickle Ball Facilities
- 8) All R-3 Residential District Permitted Uses, including apartments, townhomes and villas, and including condominium forms of ownership, but excluding single-family detached dwellings
- 9) Recreational Amenities and Residential Ancillary and Accessory Uses

Residential Mixed Use Area (Brown)

Proposed Uses:

- 1) All R-3 Residential District Permitted Uses, including townhomes and villas, and including condominium forms of ownership, but excluding apartments
- 2) Educational Facilities
- 3) Public/Private Recreation including Virtual Golf and/or Pickle Ball Facilities
- 4) All R-1A Residential District Permitted Uses (minimum lot width of 40 feet), except that no mobile homes are permitted
- 5) Recreational Amenities and Residential Ancillary and Accessory Uses

Residential Mixed Use Area

Buffers & Setbacks

20' Typical Buffer Cross Section

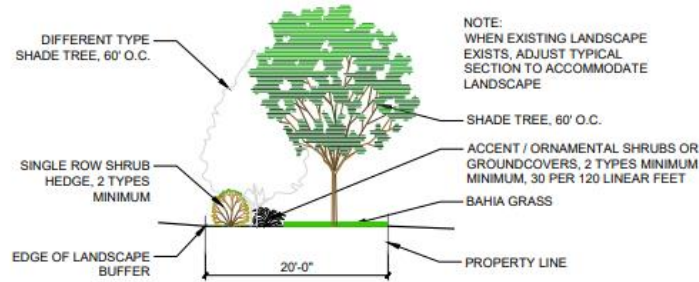

TYPE 2 BUFFER SUMMARY

2 20' TYPICAL TYPE 2 BUFFER SECTION

- 4 SHADE TREES (2 TYPES) PER 120 LF
- SINGLE ROW SHRUB HEDGE
- 30 ORNAMENTAL GRASSES, SMALL SHRUBS PER 120 LF
- BAHIA SOD WHERE NOT PLANTING BED

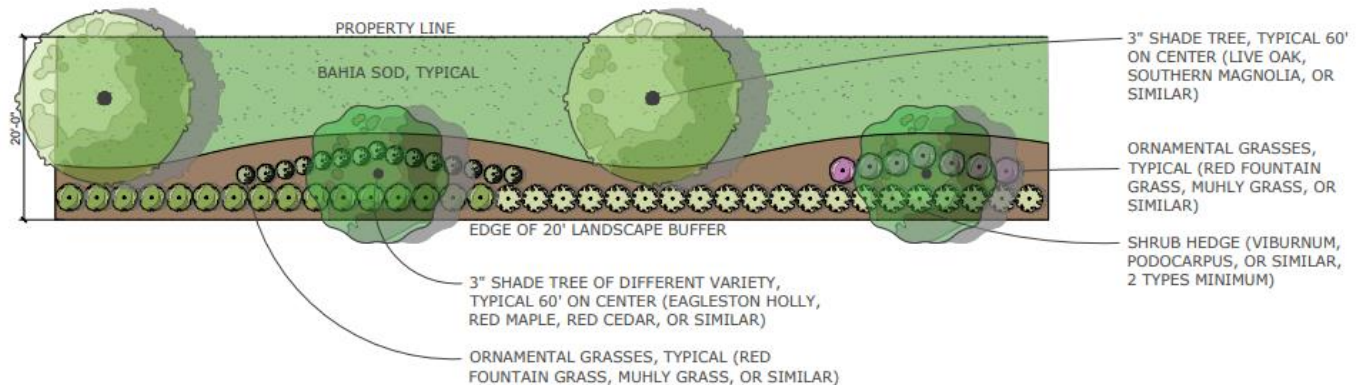

LANDSCAPE BUFFER TYPE 2 PLAN VIEW (SCALE: 1' = 10')

30' Typical Buffer Cross Section

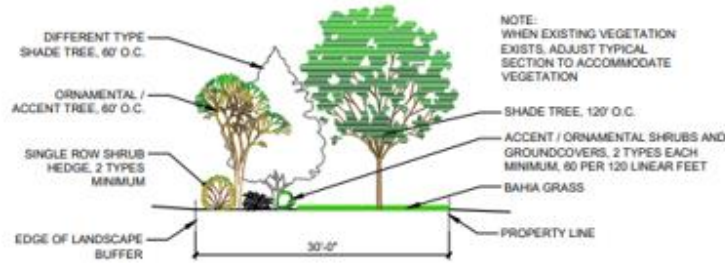

3 30' TYPICAL TYPE 3 BUFFER SECTION

TYPE 3 BUFFER SUMMARY

- 3 SHADE TREES (2 TYPES) PER 120 LF
- 2 ORNAMENTAL TREES PER 120 LF
- SINGLE ROW SHRUB HEDGE
- 60 ORNAMENTAL GRASSES, SMALL SHRUBS PER 120 LF
- BAHIA SOD WHERE NOT PLANTING BED

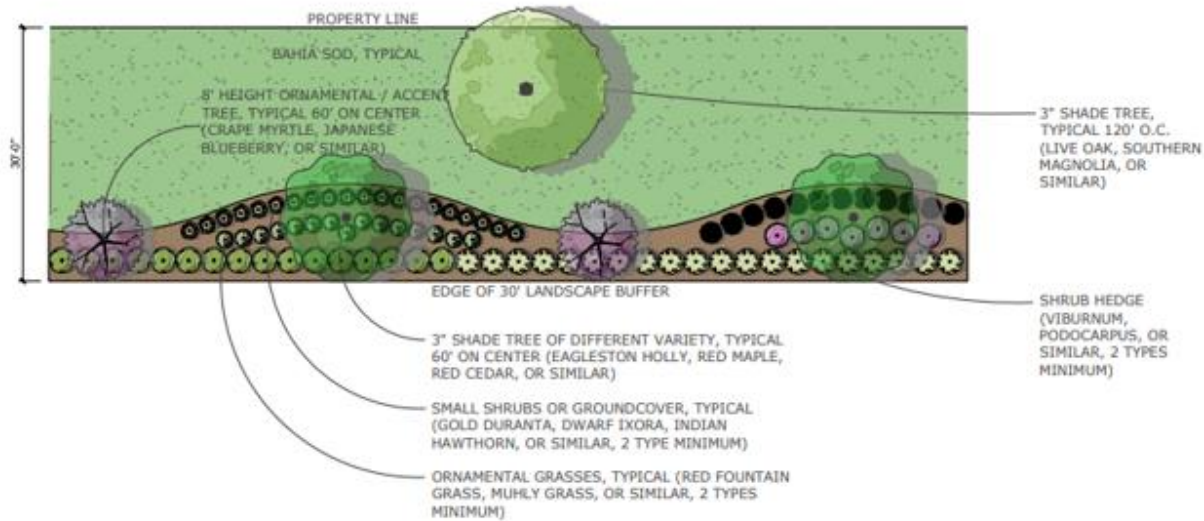

LANDSCAPE BUFFER TYPE 3 PLAN VIEW (SCALE: 1' = 10')

35' Typical Buffer Cross Section

TYPE 4 BUFFER SUMMARY

- 3 SHADE TREES (2 TYPES) PER 100 LF
- 6 ORNAMENTAL TREES PER 100 LF
- STAGGERED DOUBLE ROW SHRUB HEDGE
- 50 ORNAMENTAL GRASSES, SMALL SHRUBS PER 100 LF
- 8' FENCE OR COMBINATION BERM / FENCE
- BAHIA SEED / SOD WHERE NOT PLANTING BED

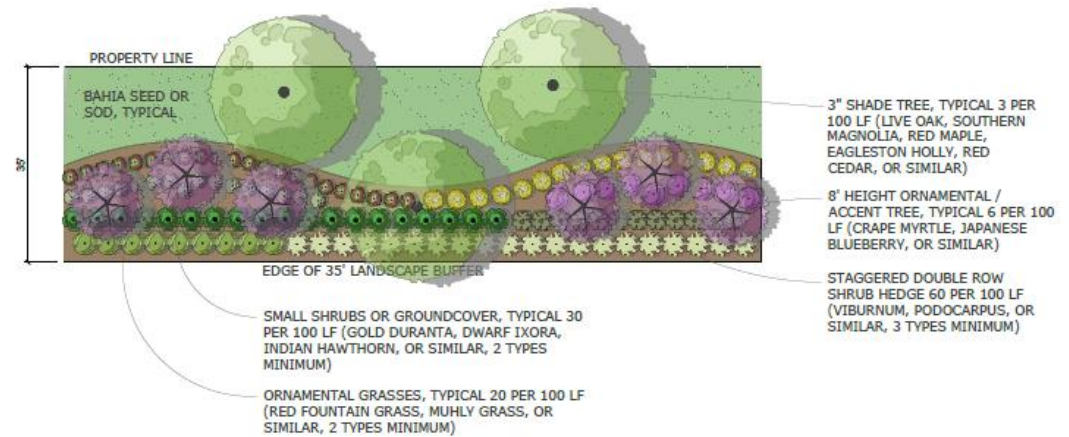
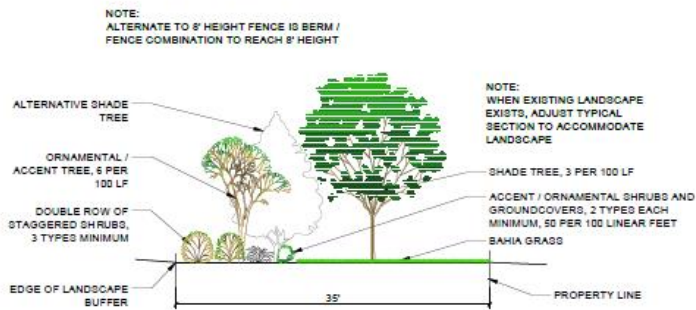

4 35' TYPICAL TYPE 4 BUFFER SECTION

LANDSCAPE BUFFER TYPE 4 PLAN VIEW (NTS)

Proposed Condition: Perimeter Buffers

Perimeter buffers shall be preserved and enhanced to achieve a minimum of **eighty percent (80%) visual opacity within thirty-six (36) months** of completion of construction. The primary intent of this requirement is to preserve existing native vegetation within the buffer to the maximum extent practicable, with such native vegetation intended to satisfy the eighty percent (80%) opacity requirement. Buffers proposed to be disturbed during construction shall be clearly identified on the construction plans and accompanied by a revegetation plan included with the landscape plans. Opacity requirements are not required to be met within the commercial buffer areas. **If existing native vegetation within a buffer does not achieve the required eighty percent (80%) opacity, the following options shall apply:**

The buffer may be selectively cleared and graded, as necessary, and replanted with landscape materials specifically designed to achieve the required eighty percent (80%) opacity. A planting landscape plan view and detailed cross-section shall be provided on the applicable phased conditional plat. For any portion of the buffer that does not meet the 80% criteria upon the initialization of construction, a construction barrier fence must be installed where immediately adjacent to residential properties in accordance with the Hernando County Land Development Regulations.

As an alternative, where the existing native vegetation does not meet the required opacity and the developer elects not to clear and replant the buffer, an eight-foot (8') opaque fence or wall may be installed along the interior edge of the buffer, in accordance with the Hernando County Land Development Regulations. In this case, existing native vegetation within the buffer shall remain undisturbed, no supplemental landscape plantings shall be required within the buffer, and only invasive vegetation may be removed.

Parks

- First 500 dwelling units = 5 acres of parks
- Each additional dwelling unit = $1/125^{\text{th}}$ of an acre
- At a maximum of 978 dwelling units:

Dwelling Units	Acreage
500 units	5 acres
Units 501-978	3.824 acres
Minimum Park Acreage:	(5 + 3.824) 8.824 acres

- Final acreage to be determined at conditional plat



Dimension & Lot Standards

Dimension & Lot Standards

Commercial Standards

	COMMERCIAL
MINIMUM LOT WIDTH	100'
MINIMUM FRONTAGE ALONG CURVE	N/A
MINIMUM LOT SQFT	N/A
MAXIMUM BUILDING HEIGHT	60'
MAXIMUM BUILDING AREA RATIO	0.75

Dimension & Lot Standards

Apartment Standards

	MULTI-FAMILY
MINIMUM LOT WIDTH	N/A
MINIMUM FRONTAGE ALONG CURVE	N/A
MINIMUM LOT SQFT	N/A
MAXIMUM BUILDING HEIGHT	60'
MAXIMUM BUILDING AREA RATIO	45%

Alternative Condition: Multifamily Standards

Condition #16 – Residential Specifications:

Apartments

- Maximum units per building: ~~24~~ 48 (Deviation from 12)
- Maximum height: ~~45~~ 60' (Deviation from 45')

Dimension & Lot Standards

Residential Mixed Use Area (Purple & Brown): Townhome Standards

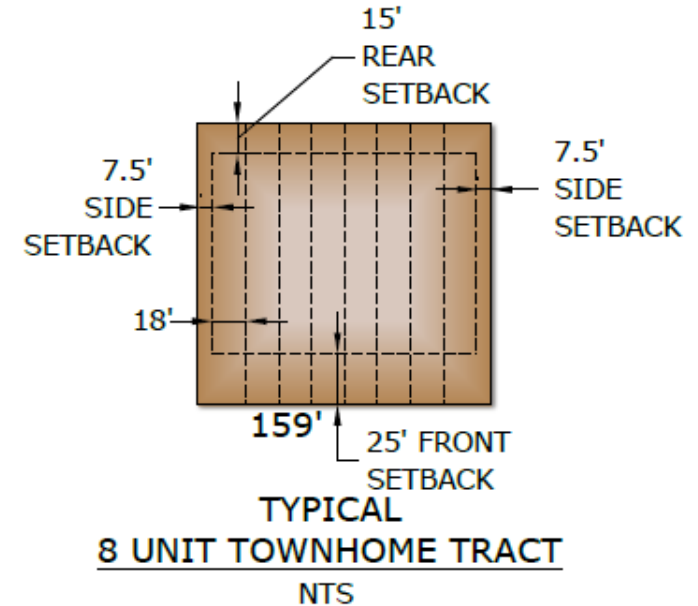
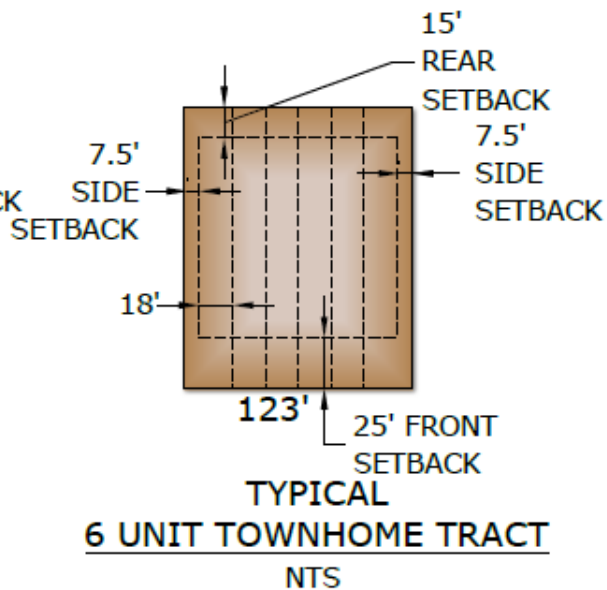
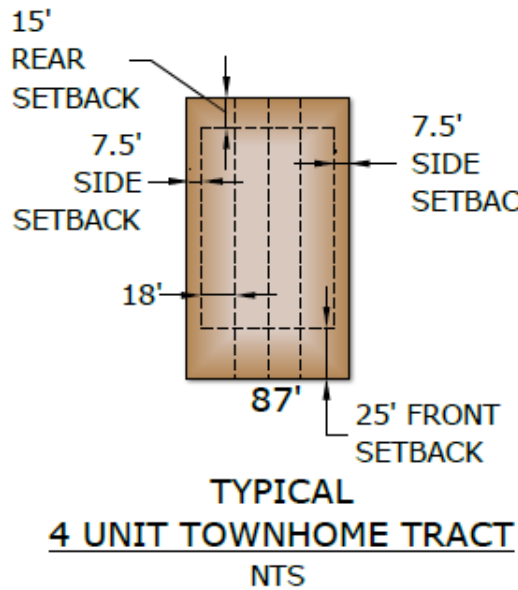

Dimension & Lot Standards

Residential Mixed Use Area (Purple & Brown): Villa Standards

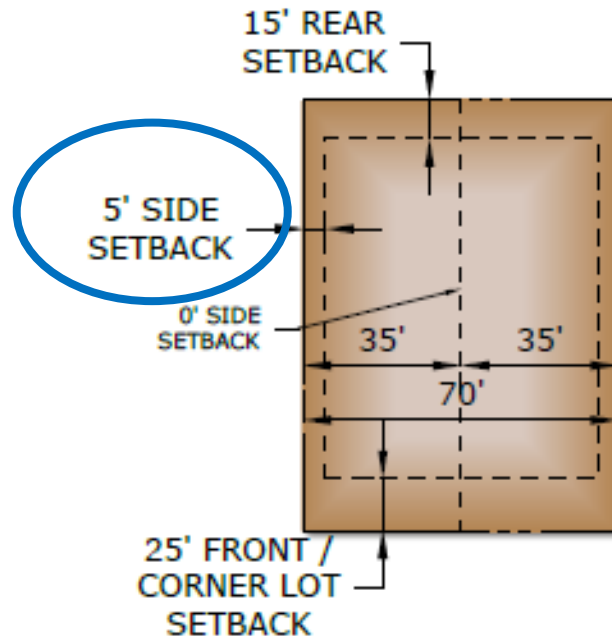

VILLA LOT MIN. REQUIREMENTS

NTS

Dimension & Lot Standards

Residential Mixed Use Area (Brown): Single Family Standards

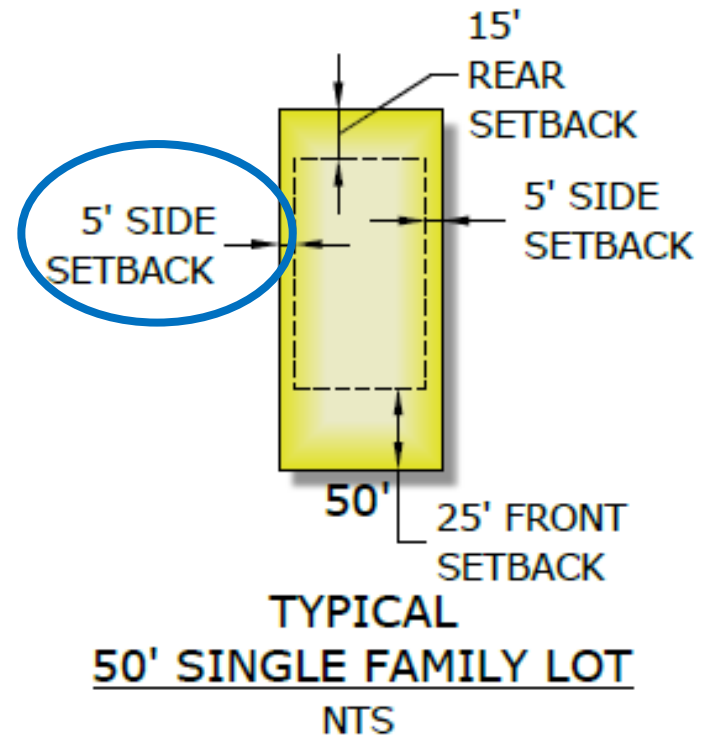
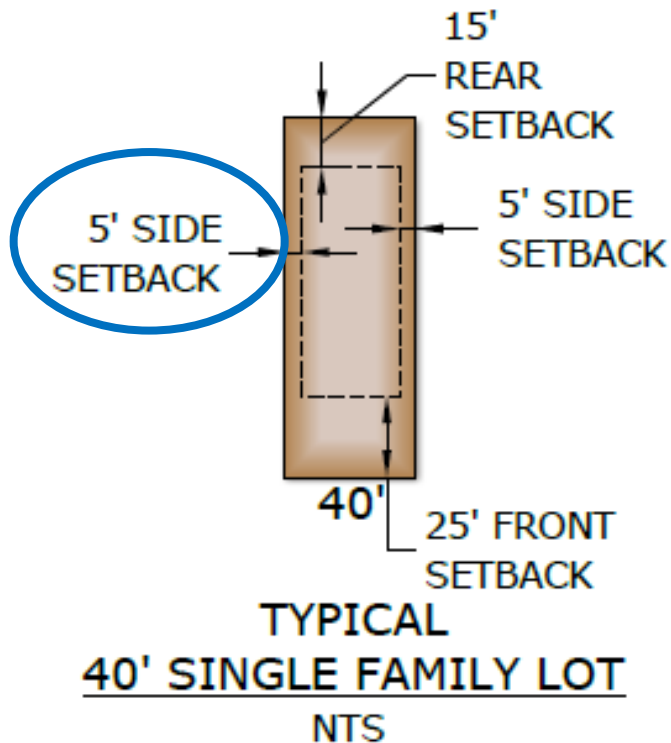

Alternative Condition: Side Setback

Condition #16 – Residential Specifications:

Single Family Lot 40'

- Side: 7.5' (Deviation from 10')

Single Family Lot 50'

- Side: 7.5' (Deviation from 10')

Villas

- Side: 0/7.5' for end units(Deviation from 10')

Parking Standards

Residential Mixed Use Area (Brown)

- Proposed condition: 10% additional holiday/visitor parking of the total parking required for the Residential Mixed-Use Area
 - 40' single family lots
 - Townhomes
 - Villas

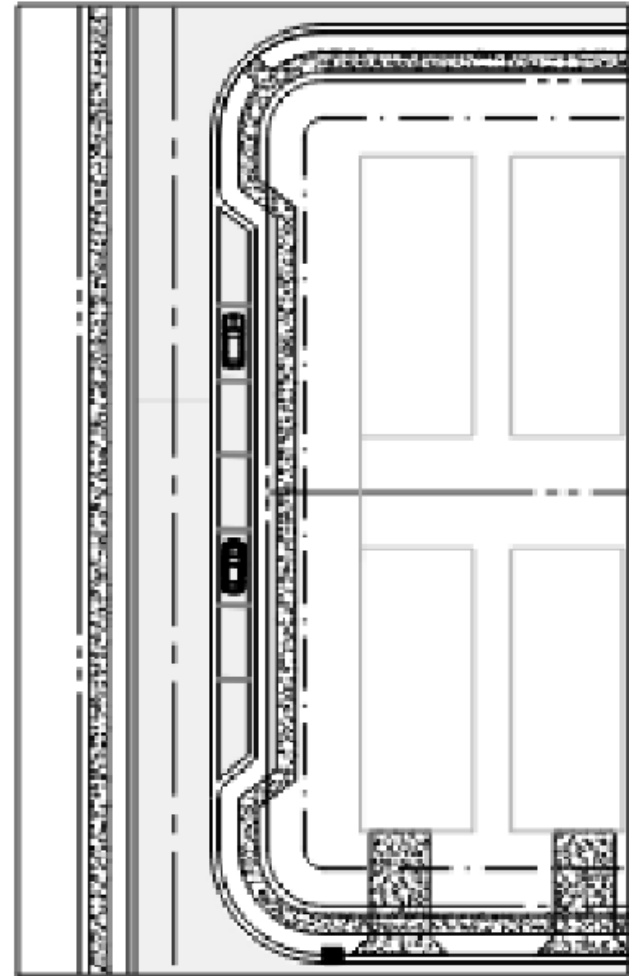

HOLIDAY PARKING DETAIL
M.T.S.

Master Plan

Transition of land uses, from north to south:

- Highway Commercial
 - Max 200,000 SF
- Commercial Mixed Use
 - Max 100,000 SF
 - Or 320 multifamily units
 - apartments, townhomes, villas
- Residential Mixed Use
 - Townhomes, villas, single family detached
- Single Family Area
 - Single family detached
 - Min. 50' wide lots

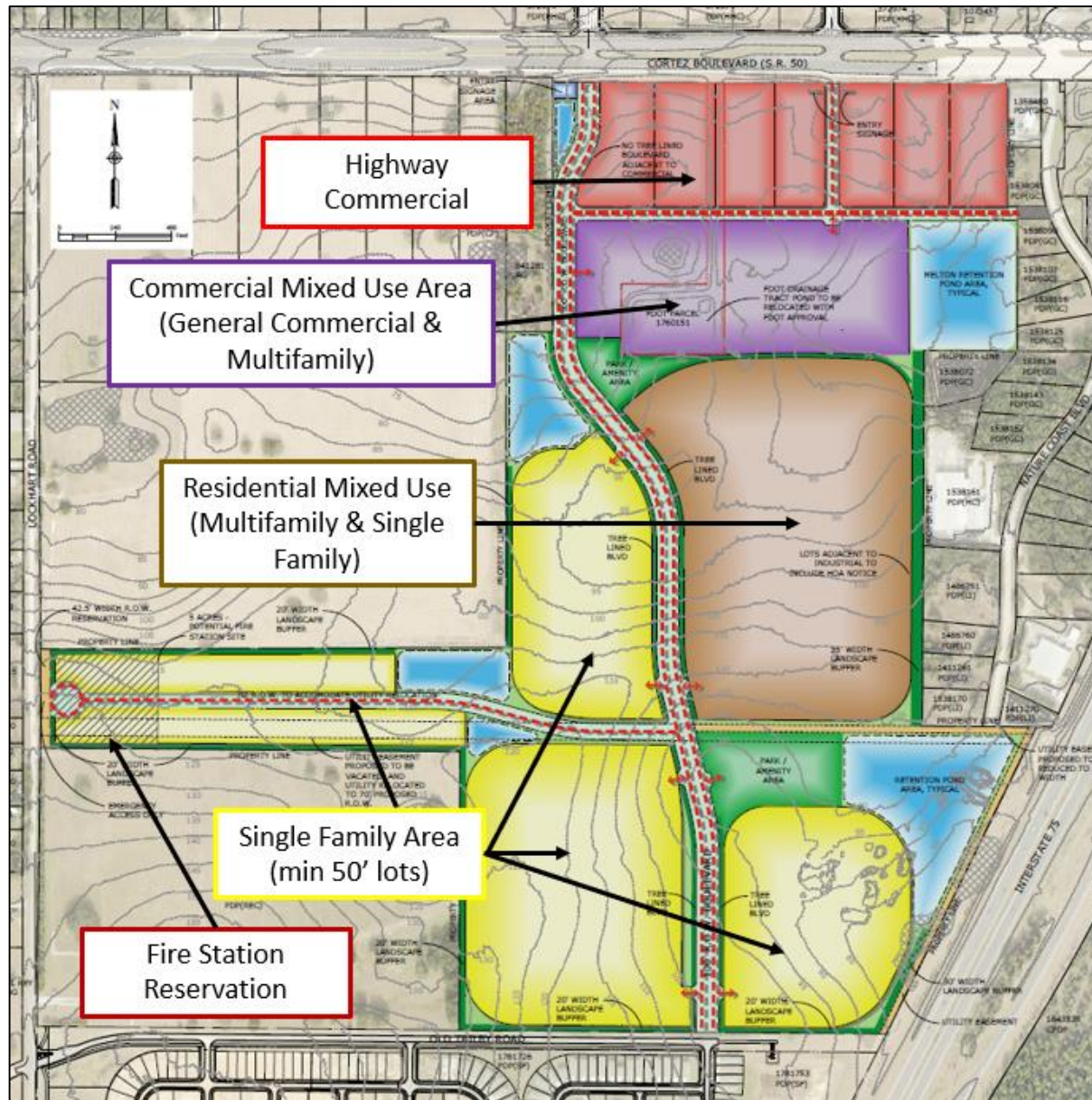

Comp Plan PDD Criteria

Strategy 1.05A(2)

Developments within the I-75/SR-50 PDD shall include a master plan utilizing the Planned Development Project process for review.

- a) Standards for a multi-modal transportation network encompassing access, circulation and connection among and between public and private properties;
- b) Planning for infrastructure needs to accommodate wastewater, potable water, fire and emergency medical service, recreation and schools;
- c) Concentration of commercial uses, mixed uses and town-center type development along and/or easily accessed from SR-50, including park and ride opportunities for future inter-county transit;
- d) Opportunities that include primary industrial uses compatible with the placement of commercial or town center areas in order to enhance employment opportunities;
- e) Attractive, convenient and safe multi-modal connections to schools, parks and other identified community focal points;
- f) Attractive, convenient and safe bike and pedestrian connection to the Withlacoochee State Trail;
- g) Standards to create a “sense of place.”

Comp Plan PDD Criteria

- a) Standards for a **multi-modal transportation network** encompassing access, circulation and connection among and between public and private properties
-

- *Internal roadway network and sidewalk system connects the residential neighborhoods to the neighborhood parks and amenities and to SR-50*
- *Additional right-of-way dedication along Lockhart Road*

Comp Plan PDD Criteria

- b) Planning for **infrastructure** needs to accommodate wastewater, potable water, fire and emergency medical service, recreation and schools
-

- *Additional right-of-way dedication along Lockhart Road*
- *Impact Fee Surcharge area*
- *A proposed Development Agreement is under review by staff to address any infrastructure deficiencies*
- *Black Jack Ridge set aside of 5 acres for future Fire/EMS Station*

Comp Plan PDD Criteria

- c) **Concentration of commercial uses**, mixed uses and town-center type development along and/or **easily accessed from SR-50**, including park and ride opportunities for future inter-county transit;
 - d) Opportunities that include primary industrial uses compatible with the placement of commercial or town center areas in order to enhance employment opportunities
-

- *Property has concentrated all commercial uses along SR-50 and reverse frontage road*
- *Up to 300,000 SF of commercial uses*

Comp Plan PDD Criteria

- e) Attractive, convenient and **safe multi-modal connections** to schools, parks and other **identified community focal points**
-

- *Internal roadway network and sidewalk system connects the residential neighborhoods to the neighborhood parks and amenities and to SR-50*
- *Multi-modal path along North-South Spine Road*

Comp Plan PDD Criteria

- f) Attractive, convenient and safe bike and pedestrian connection to the Withlacoochee State Trail
-

- *The Property is located ~1.4 miles from the Withlacoochee State Trail*
- *Will connect residents via the onsite multi-modal path to the existing sidewalk system on the southside of SR-50*

Comp Plan PDD Criteria

g) Standards to create a “sense of place.”

- *The Project is controlled by one owner, in connection with Ginny Grove*
- *Strategic location of stormwater ponds and neighborhood parks will create neighborhood focal points supported by a network of multi modal paths, sidewalks to create a highly desirable community*

Comp Plan PDD Criteria

Strategy 1.05A(3): Plans for development approval shall include a **frontage road network, alternative access,** and easements **in accordance with** long-range transportation plans of the Hernando/Citrus Metropolitan Planning Organization, and **other planning studies/transportation criteria for the I-75/SR-50 PDD**

- *The Roadway network is consistent with the I-75/SR-50 PDD Circulation Plan Study*
- *Additional right-of-way dedication along Lockhart Road*
- *Impact Fee Surcharge area*
- *A proposed Development Agreement is under review by staff to address any infrastructure deficiencies*

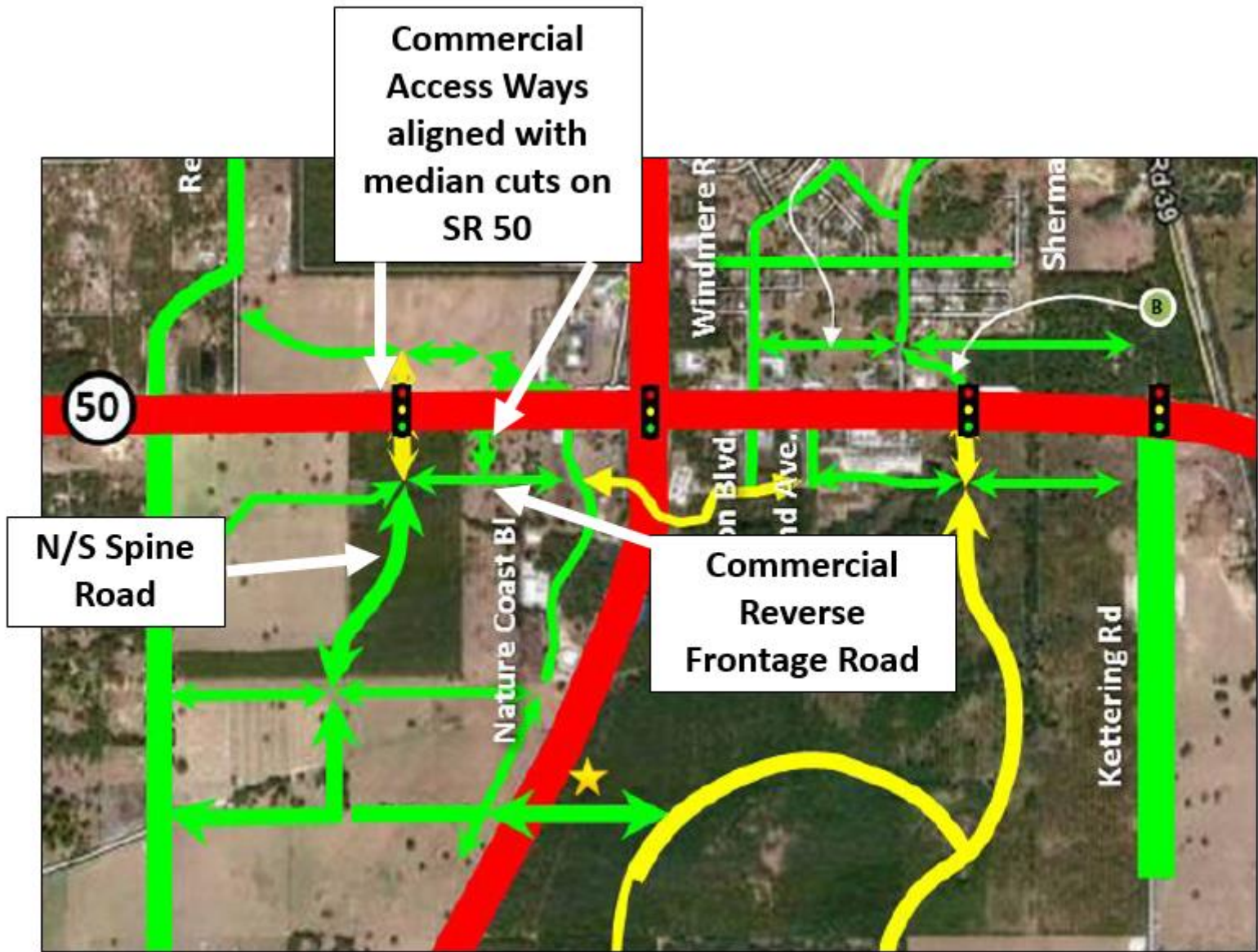

Proposed Signal



Access Roads align with existing median cuts

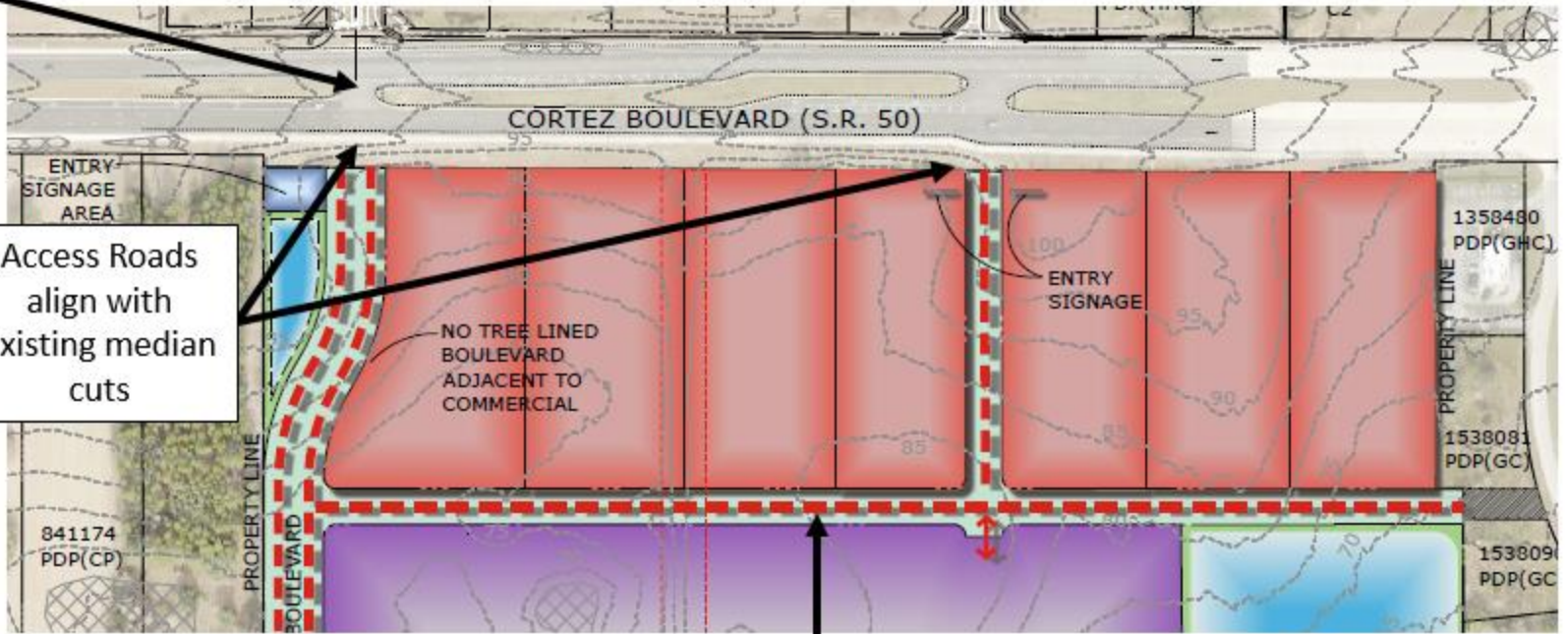

Commercial Reverse Frontage Road

Comp Plan PDD Criteria

Strategy 1.05A(6) – The County shall identify and implement **feasible funding mechanisms** to accommodate public infrastructure needs for the PDD

Description	Surcharge Amount
Schools	10%
Public Infrastructure	10%
Parks	60%
Roads	50%

Conclusion

We respectfully request you recommend approval to the Board of County Commissioners.

Questions?

THANK YOU