

SITE DATA:

1. PARCEL ID/KEY: R20-422-18-0000-0030-0000
2. AREA: 40.40 ACRES
3. OWNER: BRUGER LESA TTEE
4. CURRENT ZONING: AG
5. PROPOSED ZONING: PDP (SINGLE FAMILY)
6. PROPOSED USE: SINGLE FAMILY RESIDENTIAL
7. SURROUNDING ZONING: NORTH: AG, EAST: AG, SOUTH: AG, WEST: R1C, R1CDRA
8. FLOOD ZONE: ZONE 'AE' PER 12053C0166D EFFECTIVE: FEBRUARY 2, 2012
9. PROPOSED LOTS: 142
10. PROPOSED LOT SIZES (SEE LOT DIAGRAM, NOTE 2): 50 FT X 110 FT = 5,500 SF, 70 FT X 110 FT = 7,700 SF
11. PROPOSED DENSITY: 142 LOTS / 40.40 ACRES, 3.51 LOTS / ACRE
12. PROPOSED YARD SETBACKS: SEE LOT DIAGRAMS
13. MAX BUILDING HEIGHT: 35 FT / 2-STORIES
14. NEIGHBORHOOD PARK REQUIREMENTS: PER HERNANDO COUNTY CODE OF ORDINANCES SEC. 26-75: ONE (1) ACRE FOR FIRST 50 UNITS PLUS ONE-ONE HUNDREDTH (1/100) ACRE FOR EVERY UNIT OVER 50.
1 AC (FIRST 50 LOTS) + (.01 AC)*(142-50 LOTS) TOTAL REQUIRED = 1.92 ACRES
TOTAL PROVIDED = 1.92 ACRES
15. NATIVE VEGETATION PRESERVATION OR PLANTING REQUIREMENTS: PER HERNANDO COUNTY CODE OF ORDINANCES SEC. 10-28 (2): PROJECTS OVER 20 ACRES SHALL PROVIDE AT LEAST SEVEN (7%) OF TOTAL PROJECT AREA AS PRESERVED NATURAL VEGETATION OR INSTALLED NATIVE VEGETATION
TOTAL REQUIRED: 40.40 AC X 7% = 2.83 ACRES
TOTAL PROVIDED: 2.83 ACRES
(FINAL LOCATIONS WITHIN LANDSCAPE BUFFERS, NEIGHBORHOOD PARK, OR OTHER OPEN SPACES DEPICTED HEREON (OR ELSEWHERE) WILL BE SHOWN ON CONSTRUCTION PLANS, LOCATION HEREON ARE NOT TO BE CONSIDERED BINDING. NOTHING ON THIS MASTER PLAN OR ASSOCIATED APPROVAL SHALL BE CONSTRUED AS A COMMITMENT TO PRESERVE EXISTING NATURAL BUFFER VEGETATION OR PROHIBIT THE USE OF THE LANDSCAPE BUFFER AREAS AS DRAINAGE SWALES THAT MAY HOUSE UNDERGROUND DRAINAGE STRUCTURES.)

Received
MAR 31 2023
Planning Department
Hernando County Florida

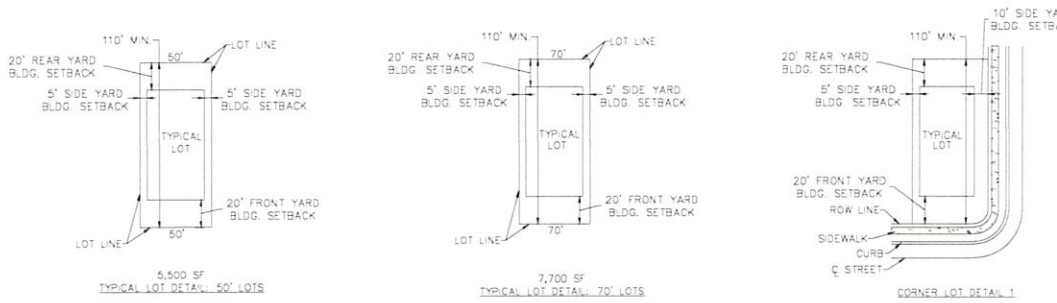
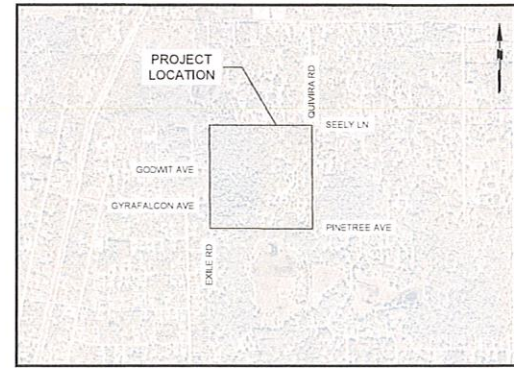

NOTE:

1. THIS IS A PLANNING DOCUMENT AND IS NOT TO BE CONSIDERED A FINAL DESIGN OR CONSTRUCTION PLANS.
2. STORMWATER MANAGEMENT AND FINAL UTILITY CONFIGURATIONS, FUNCTION, EASEMENTS, SIZE, OR LOCATIONS TO BE DETERMINED WITH THE FINAL APPROVED ENGINEERED SET OF CONSTRUCTION PLANS AND FINAL PLAT.
3. TOPOGRAPHIC INFORMATION IS APPROXIMATE AND REFERENCED FROM SOUTHWEST FLORIDA WATER MANAGEMENT MAPPING AND GIS DEPARTMENT.



LANGAN
Langan Engineering and Environmental Services, Inc.
400 N. Ashley Drive, Suite 2175
Tampa, FL 33602
T: 813.439.6100 F: 813.439.6101 www.langan.com
FL CERTIFICATE OF AUTHORIZATION NO. 00006601LB8172LB8198

Project: **BRUGER PARCEL**
OAK DEVELOPMENT GROUP, LLC
HIGH POINT
HERNANDO COUNTY FLORIDA

Drawing Title: **MASTER PLAN**

Project No.: 350069601
Date: 03-28-2023
Drawing No.: CS101
Checked By: DW
AE