

# ADA Site Review and Comments

Project: **Chinsegut Hill Retreat**  
22495 Chinsegut Hill Rd, Brooksville, FL 34601

Survey Date/Time: **May 25, 2021 @ 9:15 am**

Site Conditions: **Sunny 75 deg., minimal site traffic**

Compliance Rating: **✘ Deficiencies**



Digitally signed by Darren M Azdell  
DN: CN=Darren M Azdell,  
OU=A01410D00000173C0EBC95A00029F57,  
O=Unaffiliated, C=US  
Date: 2021.08.24 00:41:51-04'00'

Summary: **Accessible path slopes/surfaces, accessible parking space, ramps slope, emergency egress accessibility**

**General disclaimer:** The following elements were reviewed at the above listed site with deficiencies listed below. All deficiencies are based on compliance with the Americans with Disabilities Act (ADA) and the Seventh Edition 2020 Florida Accessibility Code for Building Construction (FAC) as incorporated into the 7<sup>th</sup> Edition Florida Building Code (FBC2020) per Florida Statutes 553.503. The FBC is referenced to assist with any corrections needed to comply with local codes in addition to the ADA. Site review is limited to the parking areas, drive aisles, access to and from the site from public sidewalks and transit stops, ramps and walkways lining the primary public building entrance or specific items referred to in a judgment or 3<sup>rd</sup> party inspection. Paving or painting of parking lots, sign replacements, building improvements or changes of use require compliance to the ADA. Some hardships are considered but, are rarely applied to places of public access such as office buildings and retail centers which change frequently, and maintenance is continual. Some ramp running slopes are allowed outside of required slopes when space is limited under FBC 11.4.1.6. Signage is measured with a 1" tolerance based on ADA commentary.

**Note:** Remediation contractor shall verify all elevations and dimensions prior to any remediation or construction and notify an architect or engineer for construction drawings. Building permits are required for corrective work. Recommendations or possible solutions are subject to actual site conditions measured by a land surveyor which are not included in this study/report. Lidar information provided in this report is provided by the county and is subject to survey by the general contractor's surveyor.

**Definitions:** (As defined by the ADA and fifth and seventh edition of the Florida Building Code FBC2020 - Sec 106)

**Accessible Aisle:** An accessible pedestrian space between elements, such as parking spaces.

**Accessible Route:** A continuous unobstructed path connecting all accessible elements and spaces of a building or facility. Exterior Accessible Routes include parking access aisles, curb ramps, crosswalks at vehicular ways, walks, ramps and lifts.

**Detectable Warning:** A standardized surface feature built in or applied to walking surfaces or other elements to warn visually impaired people of hazards on a circulation path.

**Cross Slope:** The slope perpendicular to the direction of travel.

**Curb Ramp:** A short ramp cutting through a curb or built up to it.

**Marked Crossing:** A crosswalk or other identified path intended for pedestrian use in crossing a vehicular way.

**Ramp:** A walking surface which has a running slope greater than 1:20. (1" Rise per 20" of Run).

Running Slope: Slope parallel to the path of travel.

NOTE: Items marked with YELLOW Dash or X are items considered to be non-compliant but, are not necessarily a barrier for a disabled person. These items should be examined more closely or at minimal be corrected with the next improvement. Items marked a RED X are items well outside of compliance and should be corrected to provide compliance.

## Subject Property:



*Image Provided by GoogleMaps for review area reference only*

**General Site Conditions**

The subject area is located in the Chinsegut Retreat on the east side of the Chinsegut Wildlife and Environmental Area. The property is owned and managed by Hernando County. The subject area includes 12 separated and distinct structures consisting of a historical manor, classroom, dining hall, bathhouse, restroom and seven cottages. (Figure 1)

Additional structures are also located on the property but, are outside of the subject area and were not reviewed.

The terrain is primarily made up of grass and sand with mulch, sand or grass paths for pedestrians and asphalt or crushed asphalt surfaces for vehicles. The property, according to the USGS Maps, indicates a high point elevation of approximately 270' ASL at the manor and a gradual slope down in all directions as referenced on the attached USGS map. (Figure 2)

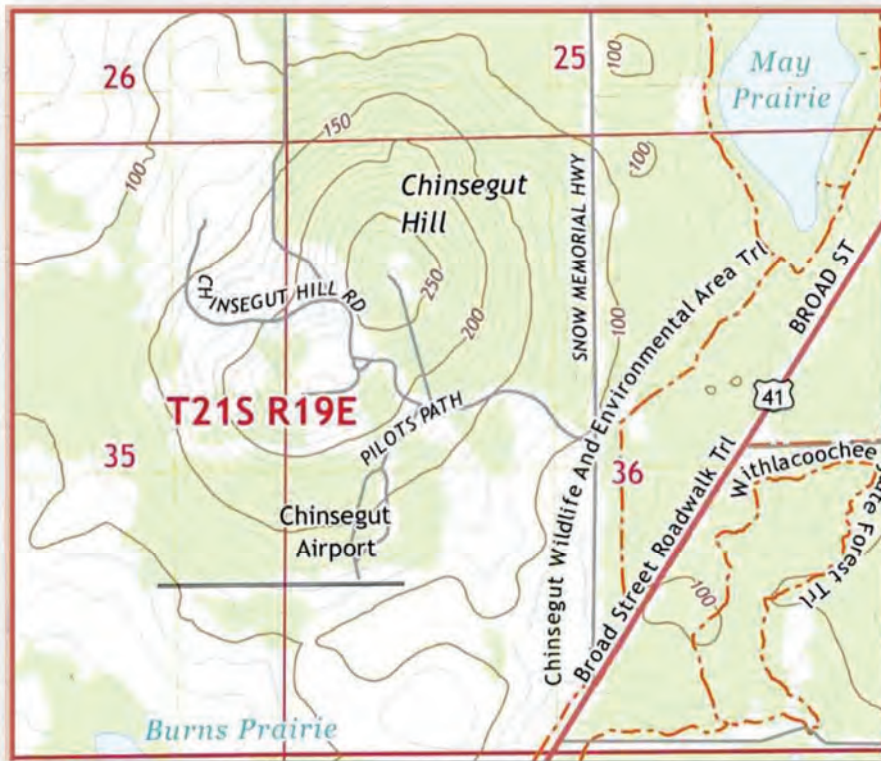

Figure 2

The subject area has a fall of approximately 35' from the homestead to the furthest building in the subject area with slopes averaging between 2% and 8%. Said terrain is idea for inclusion of accessible paths to all principal structures, manor, parking, classroom, dining hall, fire pit, bath house and designated accessible cottage with some modification of surfaces.

The general direction and severity of slope is indicated on the attached lidar map as provided by Hernando County. Each contour is equal to 1'-0" change in elevation. (Figure 3)

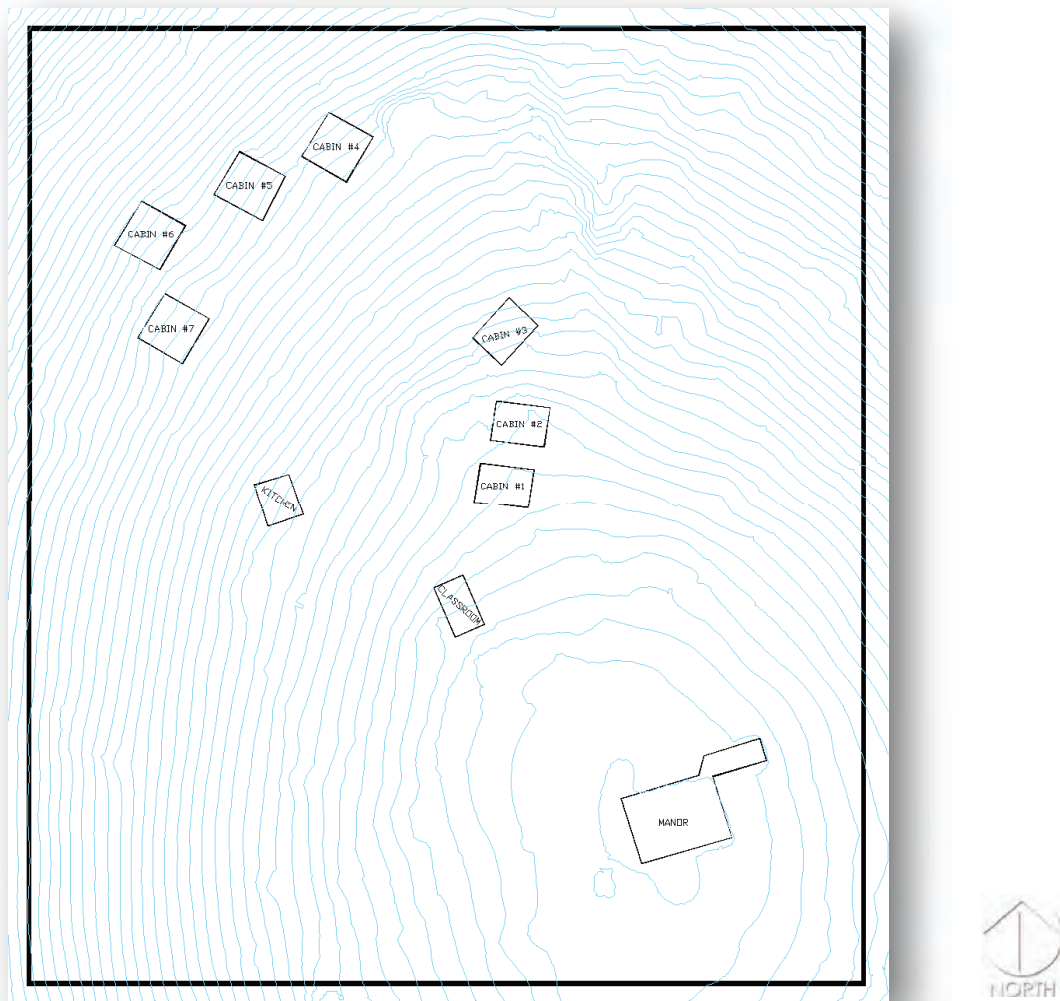

Figure 3

Identification of some building internal spaces was not possible due to some structures being locked. Further identification of these spaces (classroom, dining hall and manor) may reveal other opportunities for necessary facilities or required accessible access areas.

**Site Accessible Route Summary FAC-206.2 :**

The property is located one-half mile from the main roadway, Snow Memorial Highway (CR 581), which has no accessible sidewalk or bus stop. Thus, no accessible path is required from this roadway to the subject site. There are no immediate adjacent public parcels to the subject site requiring cross access connectivity.

**+** Public Access: Public sidewalks or public transit stops are NOT present CR 581 requiring connectivity to the site entrance. (FAC 206)

Accessible paths within this study are limited to parking areas (A, D-F), the main house (B-C), classroom (G-H), dining hall (Q), fire pit (O), bath house (I) and the designated accessible cabin #2 (J-K) (Figures 4 & 5).



Figure 4 – Aerial of retreat area, cottages, bath house, fire pit and dining hall



Figure 5 – Ariel of manor, classroom and designated parking



**Existing Parking Summary:**

Areas F, E, D, A

Total Existing Grass & Paved Spaces: 50 +/-  
 Total paved Accessible Spaces Required: 2 (FAC 208.2)  
 Total paved Accessible Spaces Provided: **1 (in parking area)**



Only 1 of the 2 required accessible spaces are provided based on available parking spaces. While the parking spaces are not delineated in the grass parking area, it is understood these areas are routinely parked for events based on perimeter provided.

**Possible Solution:** Provide an additional ADA parking space in parking area 'E' near the entrance to the retreat area. Alternately, the space may be located next to the existing parking space 'A', or if vehicles are permitted or desired in the retreat area, near the accessible cabin 'K' or at the entry to Dining Hall 'Q'. If no other vehicles are permitted in the Retreat area during retreats, location E is the most compliant area.

**Accessible parking spaces shall be paved (3000 psi concrete, 5" min. thickness is recommended on compacted soil) 12'-0" min. in width and 18'-0" in length designated with a 4" blue painted line on each side of the space with a 5'-0" wide aisle marked with 4" diagonal lines. Aisle and sidewalks shall be 4" thick concrete at a min. of 2500 psi. Spaces shall be marked with an accessible parking sign with violation notice meeting the state statues. (Figures 7 & 8)**

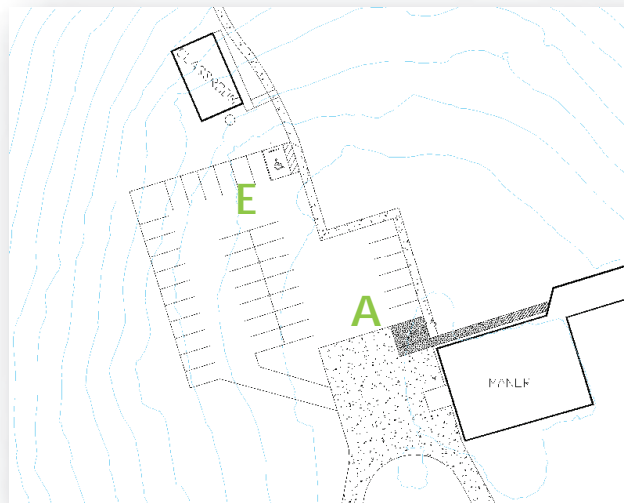

Figure 6: Proposed Accessible Parking Location

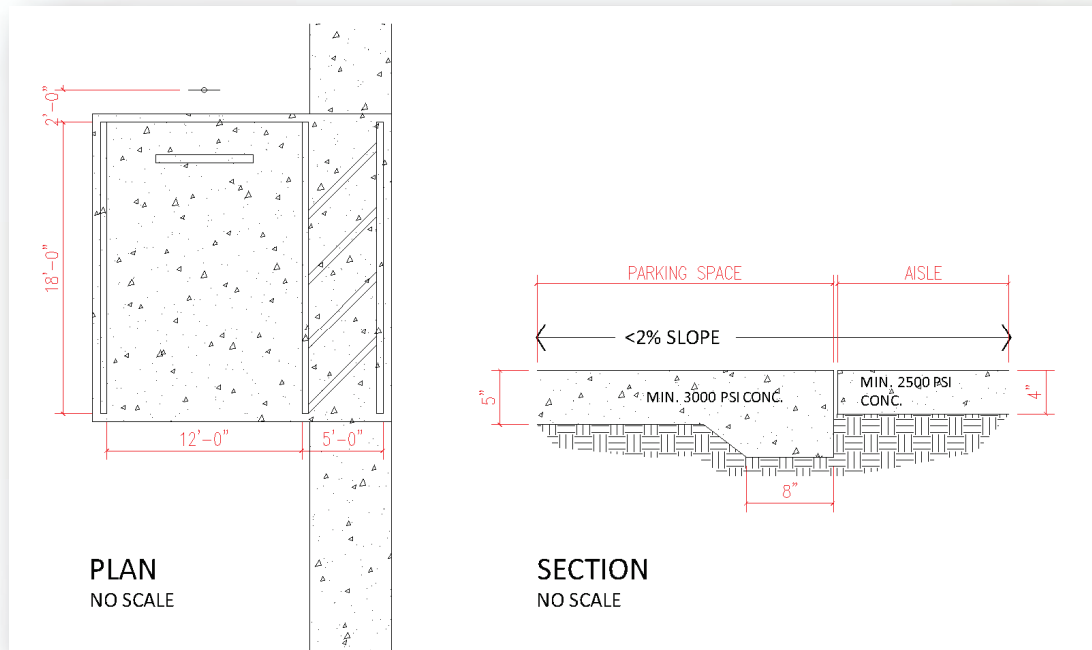

Figure 7: Proposed Accessible Space Plan Location 'E'

**Accessible Parking Space(s):**



Figure 9: Signage

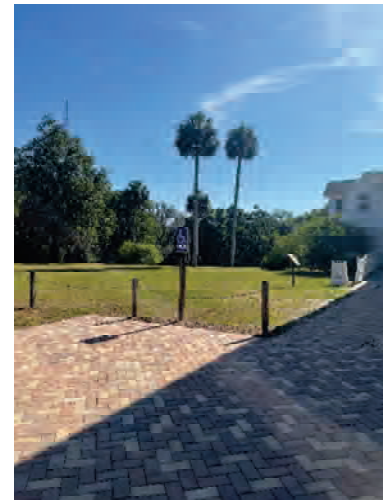

Figure 10: Parking Space

**A.1:**



Spaces: 1  
 Parking Type: 90 degree  
 Stall Size: 12'-4" X 19'-11" (12' Width Req. - FAC502.2)

Striping: Hernando County Requires Accessible Parking to be striped  
 Parking Slopes: Cross Slope = <2% (<2% or <1:48 allowed - FAC 406.3)  
 Running Slope = 2% (<2% or <1:48 allowed - FAC 406.2)

- ✘ Pole Signage: **Improper Height: 53"** (<84" & >60" Abv Grade - FAC 502.6.1)  
**Improper Type: Missing Penalty and Statue #** (International symbol of accessibility and the caption "PARKING BY DISABLED PERMIT ONLY." Such a sign, erected after October 1, 1996, must indicate the penalty for illegal use of the space and state statute #. Face of sign to be located 24" min. from face of curb.
- ✚ Aisle Width: 5'-0" (5'-0" Req. FAC502.3.1)  
 Aisle Slopes: <2% (<2% or <1:48 allowed FAC502.4)

**Possible Solution:** Remount existing sign to taller pole so bottom of sign is placed between 60" and 84" above grade. Consider adding required parking striping to comply with Hernando County Standards. (Figure 11)

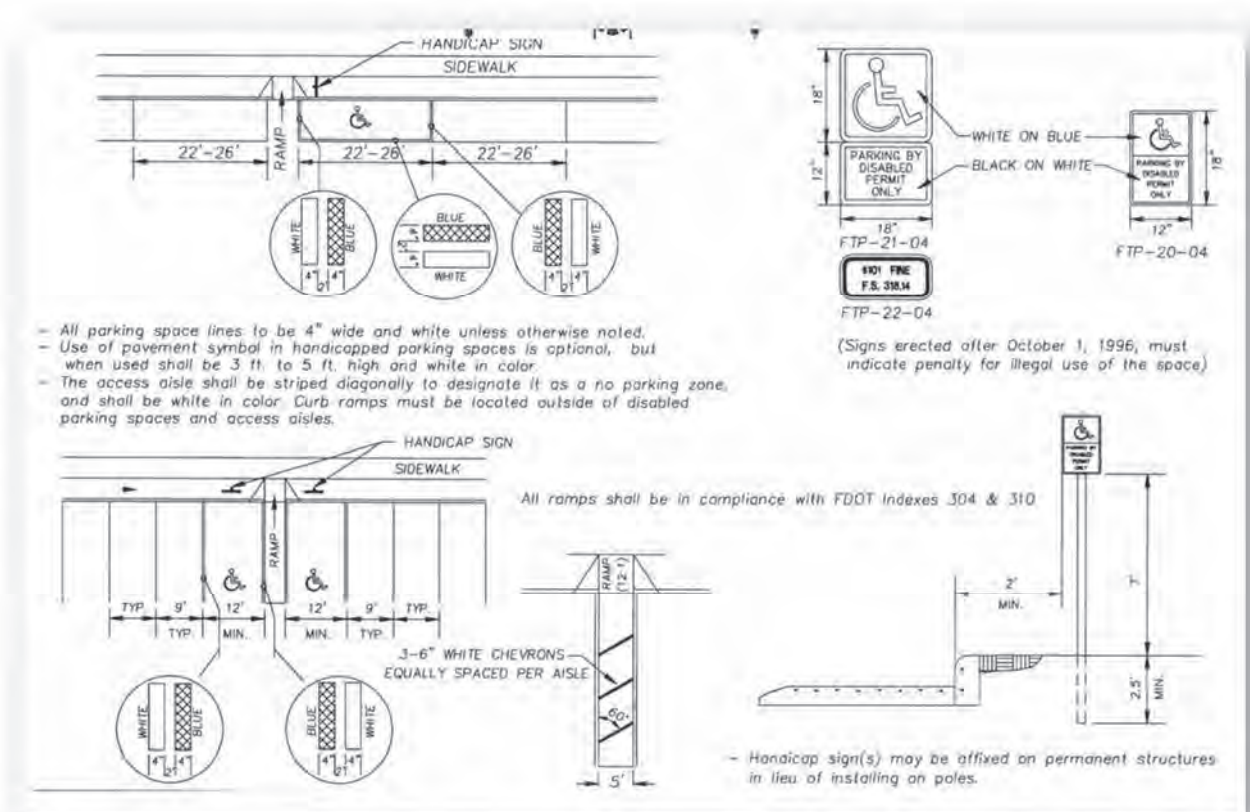

Figure 11: Hernando County Accessible Parking Standards for Locations A & E



**Accessible Paths & Ramps:**

**A-B** Accessible Path: An accessible path is present from the accessible parking area (A) to the Main House (B) via a paver sidewalk from the accessible parking space. *(Figure 12)*

- +** Width: 4'-0" (Min. 44" Egress Required)
- +** Slopes: <2% in all directions (Max. <2% Cross Slope and <5% Running Slope allowed)



*Figure 12, Accessible Path of Travel: Parking to Manor*

**B-C** Accessible Ramp: An accessible ramp exists from the parking area to the guest entry point to the manor and public accessible restrooms. Ramp is constructed of painted pressure treated lumber with railings. *(Figure 13)*

- +** Width: 5'-0" (Min. 44" Egress Required)
- +** Slopes: <2% Cross Slope & 7% Running Slope (Max. <2% Cross Slope and <8% Running Slope allowed)
- +** Length: 25' (Max. 30' allowed)
- +** Landing: 60" x 60" <2% Slope (60" x 60" @ <2% Slope Allowed)



*Figure 13, Accessible Ramp: Manor Public Entrance and Restrooms*

- Guardrail: 41"-42" (Min. 42" Required)
- Picket Spacing: 3.5" (4" Max. allowed)

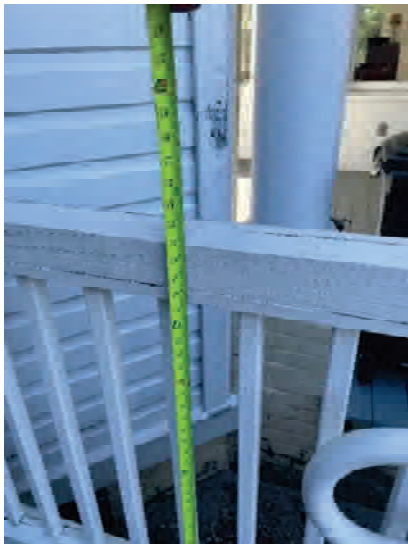

*Figure 14, Guardrail Height*



*Figure 15, Pickett Width*



Handrail Height: 34.75" (34"-38" allowed FAC 505.4)  
 Handrail Dia: 1.5" (1.5" required FAC 505.6)  
 Handrail Extension: 14" (12" min. Required FAC 505.10)  
 Handrail Clear: 1.5" (1.5" min. clearance required FAC 505.5)



Figure 16, Handrail Return



Figure 17, Handrail Clearance and Diameter



Figure 18, Handrail Extension



Figure 19, Elevation Change



Trip Hazard: **.75" change in elevation with no bevel** (.5" allowed with a .5" bevel otherwise .25" maximum allowed FAC 303.2)  
 (Figure 20)

**Possible Solution:** Replace concrete are base of ramp to provide level and consistent landing of <2% Slope.

**303.2 Vertical.**

Changes in level of  $\frac{1}{4}$  inch (6.4 mm) high maximum shall be permitted to be vertical.



**FIGURE 303.2 VERTICAL CHANGE IN LEVEL**

**303.3 Beveled.**

Changes in level between  $\frac{1}{4}$  inch (6.4 mm) high minimum and  $\frac{1}{2}$  inch (13 mm) high maximum shall be beveled with a slope not steeper than 1:2.

**Advisory 303.3 Beveled.**

A change in level of  $\frac{1}{2}$  inch (13 mm) is permitted to be  $\frac{1}{4}$  inch (6.4 mm) vertical plus  $\frac{1}{4}$  inch (6.4 mm) beveled. However, in no case may the combined change in level exceed  $\frac{1}{2}$  inch (13 mm). Changes in level exceeding  $\frac{1}{2}$  inch (13 mm) must comply with 405 (Ramps) or 406 (Curb Ramps).



**FIGURE 303.3 BEVELED CHANGE IN LEVEL**

*Figure 20 FAC Change in Level*



*Figure 21 & 22 Step Risers*



Figure 23 & 24 Step Tread Depth and Nosings



**Stair Riser:** 6.5" – 9" (Risers shall be a maximum of 7" in height and shall not vary between steps more than 3/8" over the course of the flight. FAC) (Figure 21-22)



**Stair Treads:** 9.5 - 12" (Treads shall be a minimum of 11" in depth and shall not vary between steps more than 3/8" over the course of the flight. FAC) (Figure 23-24)

**Nosing:** Top Stair nosing is 2" + (Maximum Nosing shall not exceed 1.5" FAC 505.4) (Figure 23)

**Possible Solution:** Replace steps with code compliant steps and railings.



**Landing:** <2% Slope

**Clear Door Space:** 52.5" x 60" (Min. 60" x 60" or 48" x 60" for forward approach) FAC 404.2.4.1 (Figure 25)



Figure 25, Clear Door Area / Landing

**Public Restroom:**

**C:** Accessible Restroom: An accessible restroom is located in the office/foyer space at the top of the accessible ramp at the Main House (C) (Figure 26)

**NOTE:** The Manor building is listed on the National Historic Registry. Thus, certain accessible requirements are exempt provided such requirements do not change the historic nature of the structure or grounds.

**✗** Water Closet Height: 17.5" (19" Required) (Figure 27)

**+** Side Clearance: 18" (18" required) (Figure 28)  
 Flush Lever on Room Site: Yes  
 Lavatory Depth: 21" (19" required) (Figure 31)  
 Controls: Levers are Historic (Exempt)  
 Height: 33" (32" – 34" Required) (Figure 33)

**✗** Lavatory Side Clearance: 4" (6" required) (Figure 32)  
 Scald Protection: Missing (Figure 34)

**+** Door Clearance: Push 23" (12" Required) Pull 18.5" (18" Required 24" Preferred)  
 Door Signage: Sign at 54" AFF w./ Brail (Figures 35-36)

**✗** Grab Bars: 24" Rear 48" Side (36" Rear and 48" Side) (Figures 29, 30)  
 35" High (34" – 36" Allowed) (Figure 26)  
 (Historic Exception Allowed for Window)

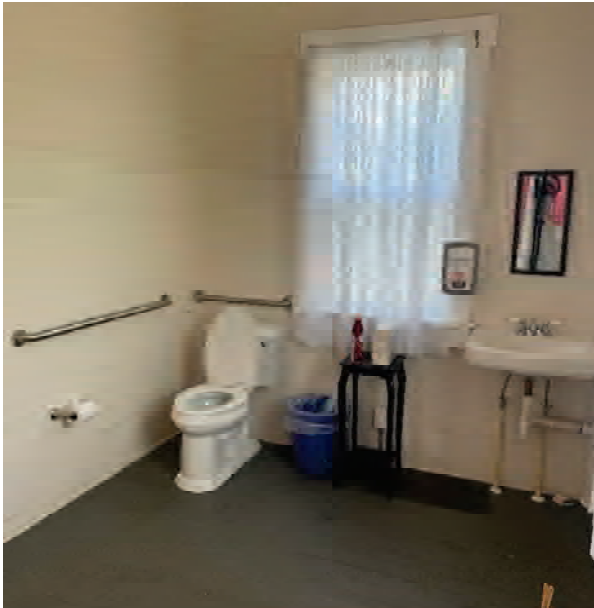
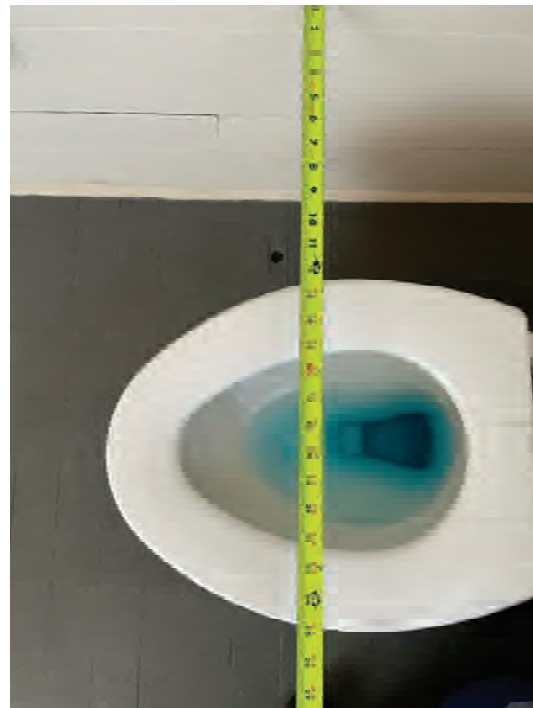

Figure 26: Accessible Restroom



Figures 27 & 28: Water Closet Height, Offset from wall



*Figures 29 & 30: Grab Bars*



*Figures 31 & 32: Lavatory: Depth & Offset from wall*



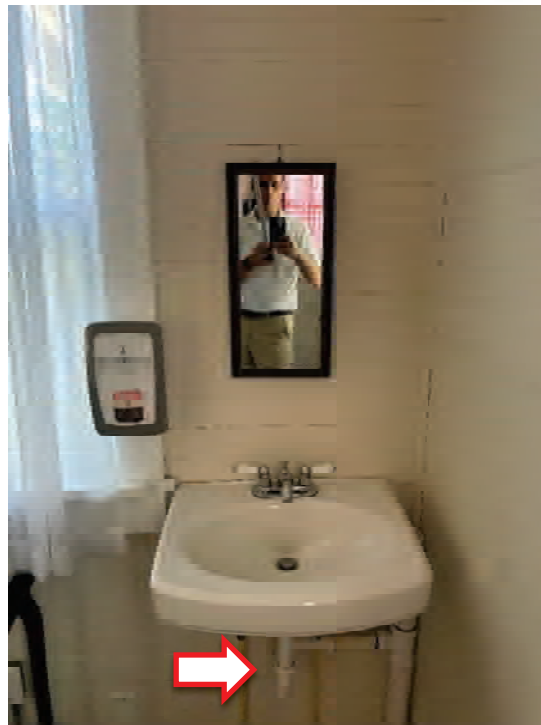

Figures 33 & 34: Lavatory: Height and Scald Protection



Figures 35 & 36: Accessible Restroom Door Clearance and Signage

Possible Solution:

A plaque in the Manor House indicated the building is on the National Registry of Historic Places and as such is

exempt from the ADA where such improvements are not physically possible or will alter the historic nature of the building. In this case, the restroom has been moderately altered and some improvements are possible. Grab bar and lavatory alterations are not possible without relocating a window and thus, NO CHANGES are possible.

The only change possible in this space is to **install scald protection on the piping under the sink.**

**D-G** Accessible Path:

An accessible path is necessary from the Manor House & Parking Area to the Classroom. A path is possible between this locations and is generally depicted in *(Figure 6)* previously shown. Said path shall be:

1. A minimum of 36" in width. A 60" wide concrete sidewalk is standard and therefore recommended to allow for passing without stepping off the path.
2. All corners (changes in direction) shall be 60" x 60" to allow for a 60" turning radius and must be less than 2% slope.
3. Slopes in the travel of direction of said path must be less than 5%. Those greater than 5% but, less than 8% shall not exceed 30'-0" in length without a landing of at least 60" in length at less than 2% slope and must have compliant railings on BOTH sides of the ramp. See Appendix.
4. Paths must be free of hazards or abrupt changes in elevation greater than 1/4" in height (or 1/2" if a 1/2" bevel is provided) otherwise known as a trip hazard.



Accessible Path:  
 Slopes:

**No Path Provided**

3% - **7%** in path of travel <2% cross slope (Max. <2% Cross Slope and <5% Running Slope allowed)



Figures 37 & 38: Accessible Path – Points D,E & G (Manor, Parking, Classroom)

**Possible Solution:**

Install a 5'-0" wide concrete sidewalk (min. 4" thick @ 2500 psi with control joints in 5'-0" increments) from the Manor House to classroom (connecting points D, E & G). Potential path indicated in (Figure 6 & 7). Path shall be no greater than 5% in slope in the direction of travel with a maximum 2% cross slope which is possible in the general path shown in Figure 6. The sidewalk can be curved to fit with the dynamics of the land and prevent abrupt changes in direction and allow avoidance of tree and tree roots.

**G.1 Classroom Stair 1:**

Classroom has a Stair/Ramp/Deck combination structure which is approximately 18" -40" above grade. (Figures 39 & 40).

- + Width: 45.5" (Min. 44" Egress Required)  
Landing: 60" x 60" <2% Slope (60" x 60" @ <2% Slope Allowed)
- ✗ Guardrail: 34" (Min. 42" Required)  
Picket Spacing: 4" (4" Max. allowed) (Figure 41)
- ✗ Handrail Height: 34" (34" -38" allowed FAC 505.4)

Handrail Dia: Non-Compliant Design (1.5" Dia. required FAC 505.6)  
 Handrail Extension: 4" (12" min. Required FAC 505.10)  
 Handrail Clear: Non-Compliant Design (1.5" min. clearance required FAC 505.5) (Figure 41)

✘ Threshold: 1" change in elevation with no bevel (.5" allowed with a .5" bevel otherwise .25" maximum allowed FAC 303.2) (Figure 41)

✘ Stair Riser: 4" – 8" (Risers shall be a maximum of 7" in height and shall not vary between steps more than 3/8" over the course of the flight. FAC) (Figure 41)

✘ Stair Treads: 9.5 - 12" (Treads shall be a minimum of 11" in depth and shall not vary between steps more than 3/8" over the course of the flight. FAC) (Figure 41)

Door Clearance: 9" (Clear space at Door Handle on pull side of door shall be a min. of 18", 24" preferred) (Figure 42)

Possible Solution: The deck height and position requires modification along with railings, guardrails, steps and as analyzed below, the ramps is also non-compliant. Thus, reconstruction of the entire deck and adjacent stairs is required. Since the classroom is built on an incline, a sketch is provided later in this report which changes the direction of the ramp to minimize slope and construction materials.

G.2 Classroom Ramp: An accessible ramp exists to the classroom. (Figure 13)

✚ Width: 45.5" (Min. 44" Egress Required)  
 Length: 16' (Max. 30' allowed)

✘ Slopes: <2% Cross Slope & 14.5% Running Slope (Max. <2% Cross Slope and <8% Running Slope allowed)

✚ Landing: 60" x 60" <2% Slope (60" x 60" @ <2% Slope Allowed)

✘ Guardrail: 34" (Min. 42" Required)  
 ✘ Picket Spacing: 48" (4" Max. allowed)  
 Handrail Dia: Non-Compliant Design (1.5" Dia. required FAC 505.6)  
 Handrail Extension: 4" (12" min. Required FAC 505.10)  
 Handrail Clear: Non-Compliant Design (1.5" min. clearance required FAC 505.5) (Figure 41)



Figures 39 & 40: Path from Manor to Classroom, Egress Ramp and Stairs







Figures 41, 42, & 43: Classroom Stair, Landing, Clearance and Ramp

**H** Classroom Stair 2:

Classroom has an egress stair for a second required egress door which is approximately 45" above grade. (Figures 44 & 45).

- ✘** Width: 40" (Min. 44" Egress Required)  
 Landing: 40" x 50" <2% Slope (60" x 60" @ <2% Slope Allowed)
- ✘** Guardrail: 34" (Min. 42" Required)  
 Picket Spacing: Varies (4" Max. allowed) (Figure 44)
- ✘** Handrail Height: 34" (34"-38" allowed FAC 505.4)  
 Handrail Dia: Non-Compliant Design (1.5" Dia. required FAC 505.6)  
 Handrail Extension: 0" (12" min. Required FAC 505.10)  
 Handrail Clear: Non-Compliant Design (1.5" min. clearance required FAC 505.5) (Figure 44)

-  **Threshold:** 6.5" change in elevation with no bevel (.5" allowed with a .5" bevel otherwise .25" maximum allowed FAC 303.2) *(Figure 47)*
  -  **Stair Riser:** 6.5" – 9.5" (Risers shall be a maximum of 7" in height and shall not vary between steps more than 3/8" over the course of the flight. FAC) *(Figure 45)*
  -  **Stair Treads:** 11.5" (Treads shall be a minimum of 11" in depth and shall not vary between steps more than 3/8" over the course of the flight. FAC) *(Figure 45)*
  -  **Door Clearance:** 3" (Clear space at Door Handle on pull side of door shall be a min. of 18", 24" preferred) *(Figure 44)*
- Possible Solution:** Stairs, railings, landing, position and height are not to code and do not meet minimum egress requirements. Full replacement of deck, ramp, landing, stairs and all railings is required. Construct new landing with min. 60" x 60" top and bottom landing, 42" guard rails for steps and deck with max. 4" spacing between pickets. Steps shall be less than 7" in height and a consistent dimension between risers. Treads shall be 12" with 1-1.5" nosings per code. Hand rails shall be installed on railings with a diameter of 1.5" with min. 2" clearance between the railing and the guardrail. Railings shall include extensions of 12" beyond last riser.



Figures 44 & 45: Classroom Egress Stair



Figures 46 & 47: Classroom Egress Door Clearance and Threshold

**L:** Exterior Bathhouse

An exterior bathhouse is located to the east of the classroom and South of Cabin 1. This bathhouse is not accessible under the ADA and cannot be modified to meet ADA requirements. Since there are ADA bathing facilities in the Accessible Cabin meeting the county and requirements for such facilities and an accessible restroom within 500' of this location this structure is excluded from this report.



*Figure 48: Bathhouse*

**L:** Accessible Lodging:

A single cottage with multiple accessible rooms is located on the site and is designated as Cottage #3 and generally marked on this assessment plan as location L. It is assumed all facilities in this cottage meet the requirements of the FAC and FBC and are excluded from review under this assessment. Thus, only access this cottage has been evaluated.

**L.1** ADA Cottage Ramp:

An accessible ramp exists to the accessible cottage on the south side of the cottage front porch. The ramp does not connect to a barrier free accessible path to accessible parking or site amenities. **(Figure 49)**



- + Width: 40.5" (Min. 36" Width Required) Building has an estimated occupant load of 6 negating the 44" egress requirement.  
 Length: 12'-6" (Max. 30' allowed)
- ✗ Slopes: <2% Cross Slope & 9.4% Running Slope (Max. <2% Cross Slope and <8% Running Slope allowed)
- + Landing: 60" x 60" <2% Slope (60" x 60" @ <2% Slope Allowed)
- ✗ Guardrail: 38.25" (Min. 42" Required)  
 Picket Spacing: 4-5/8" (4" Max. allowed)  
 Handrail Dia: Non-Compliant Design (1.5" Dia. required FAC 505.6)  
 Handrail Extension: 4" (12" min. Required FAC 505.10)  
 Handrail Clear: Non-Compliant Design (1.5" min. clearance required FAC 505.5)
- + Threshold: .25" change in elevation (.5" allowed with a .5" bevel otherwise .25" maximum allowed FAC 303.2) (*Figure 50*)



Figure 49: ADA Cottage #3 Location L Ramp

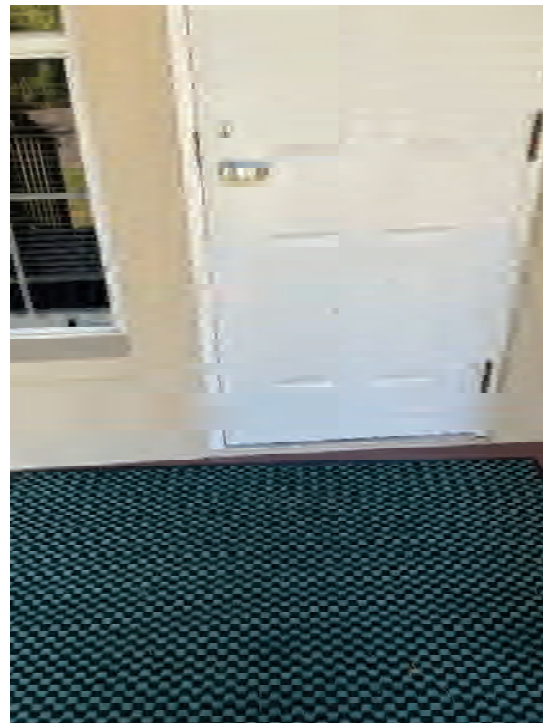

Figure 50: Threshold



Figure 51, 52, 53: ADA Cottage #3 Step Landing, Risers



Figure 54, 55, 56: ADA Cottage #3 Step Risers and Treads

## L.2 Cottage Stair 1:

Cottage has a Stair/Ramp/Deck combination structure which is approximately 18" -30" above grade. (Figure 49).

<p>Width:</p> <p>Landing:</p> <p><b>X</b> Trip Hazard:</p> <p><b>X</b> Guardrail:</p> <p>Picket Spacing:</p> <p>Handrail Height:</p>	<p>+60" (Min. 44" Egress Required)</p> <p>60" x 60" &lt;2% Slope (60" x 60" @ &lt;2% Slope Allowed)</p> <p>.75" (&lt;.25" Allowed for surfaces with changes in elevation)</p> <p>34" (Min. 42" Required)</p> <p>4" (4" Max. allowed) (Figure 49)</p> <p>34" (34"-38" allowed FAC 505.4)</p>
--	---

- ✘ Handrail Dia: Non-Compliant Design (1.5" Dia. required FAC 505.6)
- ✘ Handrail Extension: 4" (12" min. Required FAC 505.10)
- ✘ Handrail Clear: Non-Compliant Design (1.5" min. clearance required FAC 505.5) (*Figure 49*)
- ✘ Stair Riser: 7" – 9" (Risers shall be a maximum of 7" in height and shall not vary between steps more than 3/8" over the course of the flight. FAC) (*Figure 54*)
- ✘ Stair Treads: 12 -13.5" (Treads shall be a minimum of 11" in depth and shall not vary between steps more than 3/8" over the course of the flight. FAC) (*Figure 55-56*)
- ✘ Stair Nosing: 0 – 1.5" (Each step shall have a 1" – 1.5" nosing. FAC)

**Possible Solution:** Replace warped pressure treated deck boards at top landing (deck) and secure with stainless steel fasteners or Polyester Epoxy coated deck screws. Demolish and replace existing steps with Pressure treated steps set on concrete foundation or replace with concrete steps with 7" risers and 12" treads with 1" nosing on each step.

**H-Q Accessible Path:** No Accessible Path exists connecting public spaces on the site to include the Manor House (B), Parking Area (A&E), Classroom Cottage 2 (K), Fire Pit (O) and Dining Hall (Q). Excluded from this requirement are cottages 4-7 which are not required to be on an accessible route as these are not accessible lodging. (*Figure 63*)

**Slopes:**  
 A-E: <2% Slope in the direction of travel  
 E-H: 3%-7% Slope in the direction of travel. (Requires arc in sidewalk path to reduce slope to <5%).  
 H-K: 4% Slope in the direction of travel  
 L-M-N: 4% Slope in the direction of travel  
 N-P-Q: 5% Slope in the direction of travel. (Requires arc in sidewalk path to reduce slope to <5%).

**Possible Solution:** Install a 5'-0" wide concrete sidewalk (min. 4" thick @ 2500 psi with control joints in 5'-0" increments) from the Manor House to Dining Hall (connecting points A, D, E, G, H, K, O and Q). Potential path indicated in (*Figures 56-57*). Path shall be no greater than 5% in slope in the direction of travel with a maximum 2% cross slope which is possible in

the general path shown in Figure 6. The sidewalk can be curved to fit with the dynamics of the land, reduce slope to less than 5%. prevent abrupt changes in direction requiring landings and avoid trees and tree roots. (Figures 57-61, 63)



Figure 57: Accessible Path H-O (yellow) and O-Q (red)



Figure 58: Accessible Path H-K

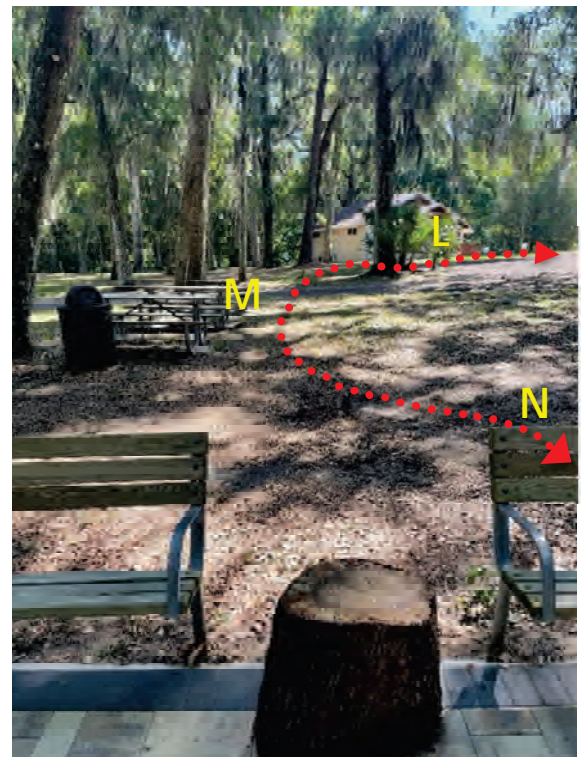

Figure 59: Accessible Path L-N



Figure 60: Accessible Path N-Q (red)



Figure 61: Accessible Path P-Q

### Q.1 ADA Cottage Ramp:

An accessible ramp exists to the dining room from the crushed asphalt drive. The ramp currently does not connect to a barrier free accessible path to accessible parking or other site amenities. (Figure 62)



Width:  
Slope (Conc.):

48" (Min. 44" Egress Width Required)  
3% Slope in the direction of travel <2% Cross Slope (<5% Allowed in direction of travel and <2% Cross Slope)



Slope (Pavers):

4.1%-5.2% Slope in direction of travel and <2% Cross Slope (<5% Allowed in direction of travel and <2% Cross Slope) (Figure 62)



Landing:

60" x 60" 4% Slope (60" x 60" @ <2% Slope Allowed) (Figure 62)

#### Possible Solution:

Demolish concrete sidewalk with landing at door and approximately 10' of paver sidewalk. Replace with new 5'-0" wide 4" thick concrete sidewalk from front door to location 'Q' where walk N-P-Q connects. Provide level (<2% slope) landing 60" x 60" at front door of dining hall and at intersection of sidewalks (Point Q). All slopes between shall be <5% slope in the direction of travel with a cross slope of <2%. It is recommended that the sidewalk connect to the existing ice machine patio at the front of the building to improve accessibility to that service.



Figure 62: Ramp Q

### A-Q Site Lighting:

An accessible path is required to have minimum lighting at the exterior of 0.2 Foot Candle (2.15 Lux) at the walking surface. (FBC 1008.2.1 Exception 2). Steps, landings and the sides of ramps shall be permitted to be marked with self-luminous materials in accordance with Sections 1025.2.1, 1025.2.2 and 1025.2.4 by systems listed in accordance with UL 1994. The exterior accessible path, building ramps, porches and landings were not observed in low natural lighting conditions with the exterior lighting fixtures on. It is recommended that the lighting levels be measured at the walking surfaces of the accessible path. *(Figure 63)*

### Possible Solution:

**If lighting levels at the exterior accessible path measure less than 0.2 Foot Candle (2.15 Lux), install full-cut-off lighting fixtures intermittently to provide minimum lighting levels. Note, fixtures can be specified which are motion activated, solar powered with batteries which are ideal for commercial applications and can be mounted to poles. An electrical engineer is recommended for this phase of work.**

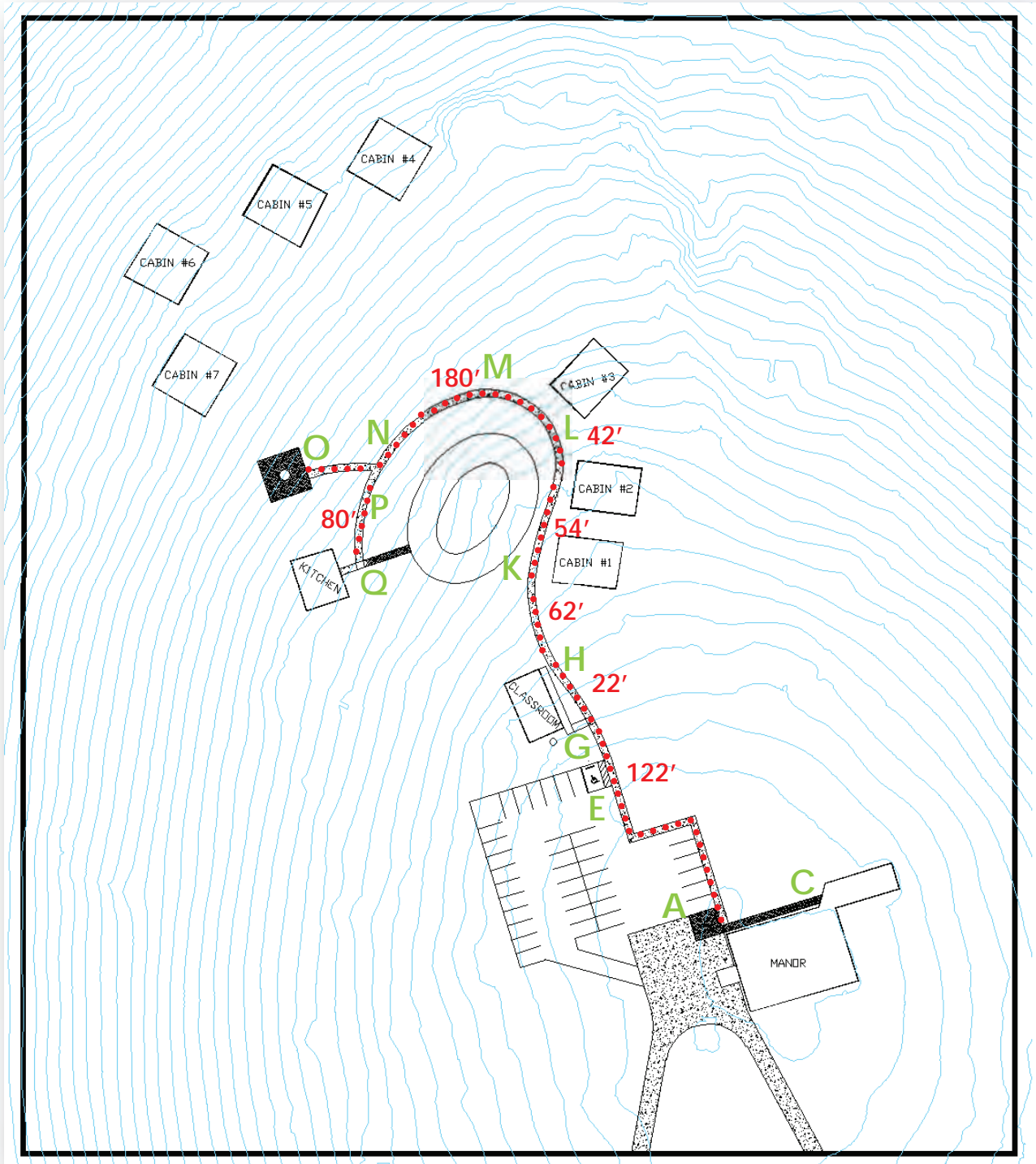

Figure 63: Accessible Path A-Q

APPENDIX A:  
 FLORIDA ACCESSIBILITY CODE AND LOCAL COUNTY GUIDELINES / REFERENCE INFORMATION

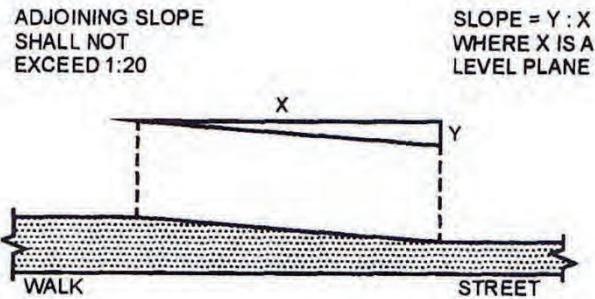

FIGURE 11  
 MEASUREMENT OF CURB RAMP SLOPES

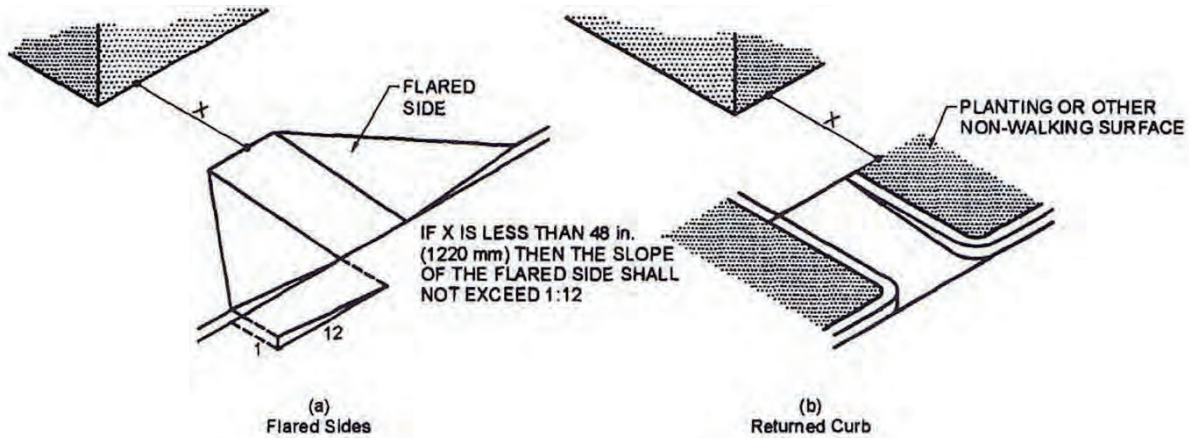

FIGURE 12  
 SIDES OF CURB RAMPS

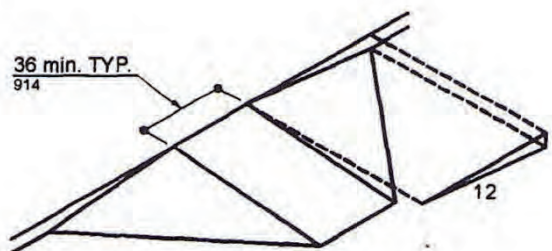
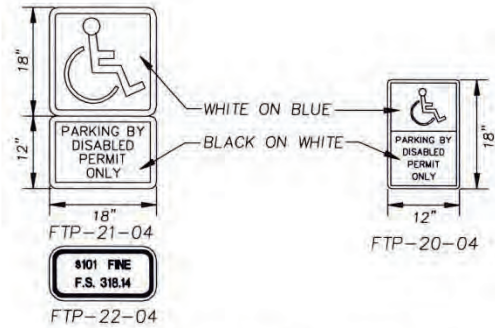
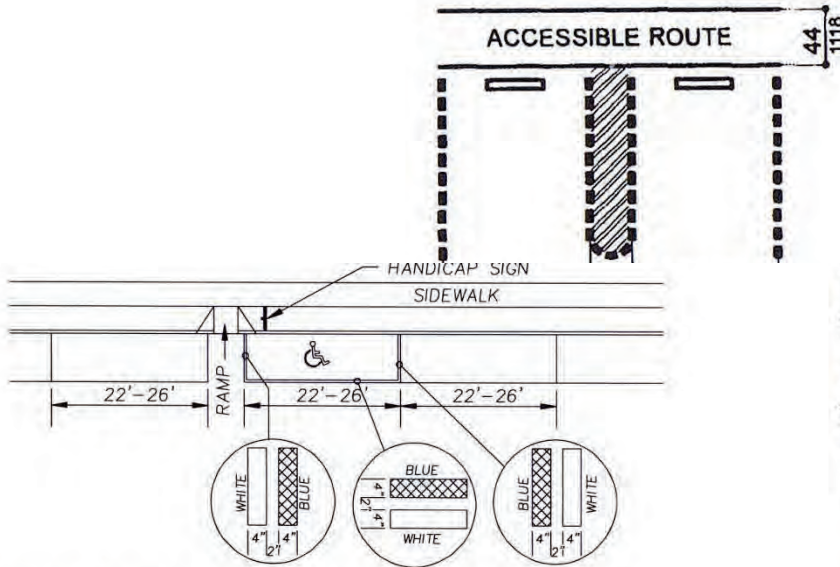

FIGURE 13  
 BUILT-UP CURB RAMP





- All parking space lines to be 4" wide and white unless otherwise noted.
- Use of pavement symbol in handicapped parking spaces is optional, but when used shall be 3 ft. to 5 ft. high and white in color.
- The access aisle shall be striped diagonally to designate it as a no parking zone, and shall be white in color. Curb ramps must be located outside of disabled parking spaces and access aisles.

(Signs erected after October 1, 1996, must indicate penalty for illegal use of the space)

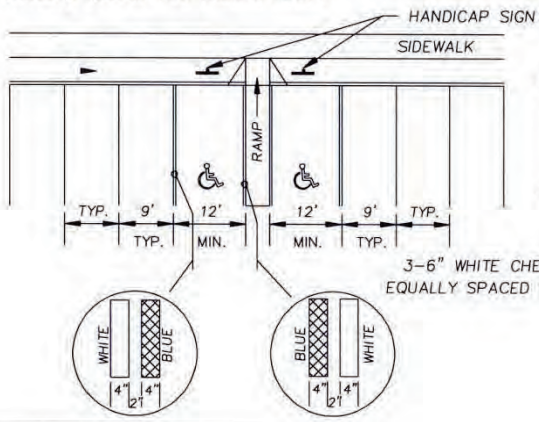

All ramps shall be in compliance with FDOT Indexes 304 & 310

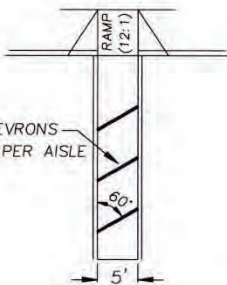

3-6" WHITE CHEVRONS EQUALLY SPACED PER AISLE

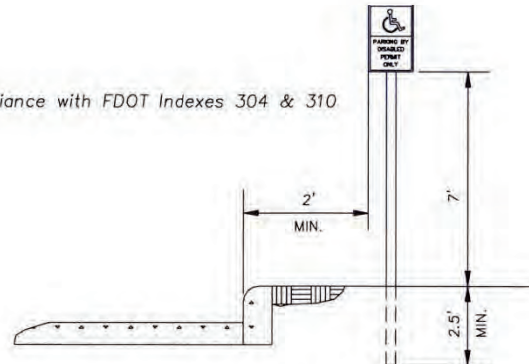

- Handicap sign(s) may be affixed on permanent structures in lieu of installing on poles.

The following sections are referenced from the Florida Building Code - 5<sup>th</sup> Edition and are provided for general reference only.

**302.3 Openings.**

Openings in floor or ground surfaces shall not allow passage of a sphere more than 1/2 inch (13 mm) diameter except as allowed in 407.4.3, 409.4.3,

410.4, 810.5.3 and 810.10. Elongated openings shall be placed so that the long dimension is perpendicular to the dominant direction of travel.

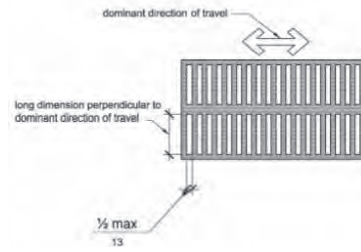

**FIGURE 302.3 ELONGATED OPENINGS IN FLOOR OR GROUND SURFACES**

### 303 CHANGES IN LEVEL

#### 303.1 General.

Where changes in level are permitted in floor or ground surfaces, they shall comply with 303.

#### EXCEPTIONS:

1. Animal containment areas shall not be required to comply with 303.
2. Areas of sport activity shall not be required to comply with 303.

#### 303.2 Vertical.

Changes in level of  $\frac{1}{4}$  inch (6.4 mm) high maximum shall be permitted to be vertical.



**FIGURE 303.2 VERTICAL CHANGE IN LEVEL**

#### 303.3 Beveled.

Changes in level between  $\frac{1}{4}$  inch (6.4 mm) high minimum and  $\frac{1}{2}$  inch (13 mm) high maximum shall be beveled with a slope not steeper than 1:2.

#### Advisory 303.3 Beveled.

A change in level of  $\frac{1}{2}$  inch (13 mm) is permitted to be  $\frac{1}{4}$  inch (6.4 mm) vertical plus  $\frac{1}{4}$  inch (6.4 mm) beveled. However, in no case may the combined change in level exceed  $\frac{1}{2}$  inch (13 mm). Changes in level exceeding  $\frac{1}{2}$  inch (13 mm) must comply with 405 (Ramps) or 406 (Curb Ramps).

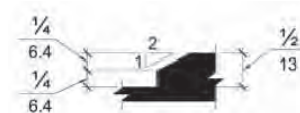

**FIGURE 303.3 BEVELED CHANGE IN LEVEL**

#### 303.4 Ramps.

Changes in level greater than  $\frac{1}{2}$  inch (13 mm) high shall be ramped, and shall comply with 405 or 406.

### FBC 505 HANDRAILS

#### 505.1 General.

Handrails provided along walking surfaces complying with 403, required at ramps complying with 405, and required at stairs complying with 504 shall comply with 505.

#### Advisory 505.1 General.

Handrails are required on ramp runs with a rise greater than 6 inches (150 mm) (see 405.8) and on certain stairways (see 504). Handrails are not required on walking surfaces with running slopes less than 1:20. However, handrails are required to comply with 505 when they are provided on walking surfaces

with running slopes less than 1:20 (see 403.6). Sections 505.2, 505.3, and 505.10 do not apply to handrails provided on walking surfaces with running slopes less than 1:20 as these sections only reference requirements for ramps and stairs.

**505.2 Where Required.**

Handrails shall be provided on both sides of stairs and *ramps*.

**EXCEPTION:** In *assembly areas*, handrails shall not be required on both sides of aisle *ramps* where a handrail is provided at either side or within the aisle width.

**505.3 Continuity.**

Handrails shall be continuous within the full length of each stair flight or *ramp* run. Inside handrails on switchback or dogleg stairs and *ramps* shall be continuous between flights or runs.

**EXCEPTION:** In *assembly areas*, handrails on *ramps* shall not be required to be continuous in aisles serving seating.

**505.4 Height.**

Top of gripping surfaces of handrails shall be 34 inches (865 mm) minimum and 38 inches (965 mm) maximum vertically above walking surfaces, stair nosings, and *ramp* surfaces. Handrails shall be at a consistent height above walking surfaces, stair nosings, and *ramp* surfaces.

**Advisory 505.4 Height.**

The requirements for stair and ramp handrails in this code are for adults. When children are the principal users in a building or facility (e.g., elementary schools), a second set of handrails at an appropriate height can assist them and aid in preventing accidents. A maximum height of 28 inches (710 mm) measured to the top of the gripping surface from the ramp surface or stair nosing is recommended for handrails designed for children. Sufficient vertical clearance between upper and lower handrails, 9 inches (230 mm) minimum, should be provided to help prevent entrapment.

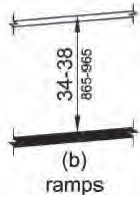

**FIGURE 505.4 HANDRAIL HEIGHT**

**505.5 Clearance.**

Clearance between handrail gripping surfaces and adjacent surfaces shall be 1½ inches (38 mm) minimum.



**FIGURE 505.5 HANDRAIL CLEARANCE**

**505.6 Gripping Surface.**

Handrail gripping surfaces shall be continuous along their length and shall not be obstructed along their tops or sides. The bottoms of handrail gripping surfaces shall not be obstructed for more than 20 percent of their length. Where provided, horizontal projections shall occur 1½ inches (38 mm) minimum below the bottom of the handrail gripping surface.

**EXCEPTIONS:**

1. Where handrails are provided along walking surfaces with slopes not steeper than 1:20, the bottoms of handrail gripping surfaces shall be permitted to be obstructed along their entire length where they are integral to crash rails or bumper guards.

2. The distance between horizontal projections and the bottom of the gripping surface shall be permitted to be reduced by  $\frac{1}{8}$  inch (3.2 mm) for each  $\frac{1}{2}$  inch (13 mm) of additional handrail perimeter dimension that exceeds 4 inches (100 mm).

**Advisory 505.6 Gripping Surface.**

People with disabilities, older people, and others benefit from continuous gripping surfaces that permit users to reach the fingers outward or downward to grasp the handrail, particularly as the user senses a loss of equilibrium or begins to fall.



**FIGURE 505.6 HORIZONTAL PROJECTIONS BELOW GRIPPING SURFACE**

**505.7 Cross Section.**

Handrail gripping surfaces shall have a cross section complying with 505.7.1 or 505.7.2.

**505.7.1 Circular Cross Section.**

Handrail gripping surfaces with a circular cross section shall have an outside diameter of  $1\frac{1}{4}$  inches (32 mm) minimum and 2 inches (51 mm) maximum.

**505.7.2 Non-Circular Cross Sections.**

Handrail gripping surfaces with a non-circular cross section shall have a perimeter dimension of 4 inches (100 mm) minimum and  $6\frac{1}{4}$  inches (160 mm) maximum, and a cross-section dimension of  $2\frac{1}{4}$  inches (57 mm) maximum.

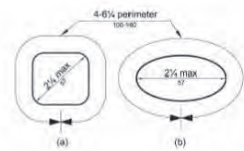

**FIGURE 505.7.2 HANDRAIL NON-CIRCULAR CROSS SECTION**

**505.8 Surfaces.**

Handrail gripping surfaces and any surfaces adjacent to them shall be free of sharp or abrasive *elements* and shall have rounded edges.

**505.9 Fittings.**

Handrails shall not rotate within their fittings.

**505.10 Handrail Extensions.**

Handrail gripping surfaces shall extend beyond and in the same direction of stair flights and *ramp* runs in accordance with 505.10.

**EXCEPTIONS:**

- Extensions shall not be required for continuous handrails at the inside turn of switchback or dogleg stairs and *ramps*.
- In *assembly areas*, extensions shall not be required for *ramp* handrails in aisles serving seating where the handrails are discontinuous to provide access to seating and to permit crossovers within aisles.
- In *alterations*, full extensions of handrails shall not be required where such extensions would be hazardous due to plan configuration.

**505.10.1 Top and Bottom Extension at Ramps.**

*Ramp* handrails shall extend horizontally above the landing for 12 inches (305 mm) minimum beyond the top and bottom of *ramp* runs. Extensions shall return to a wall, guard, or the landing surface, or shall be continuous to the handrail of an adjacent *ramp* run.

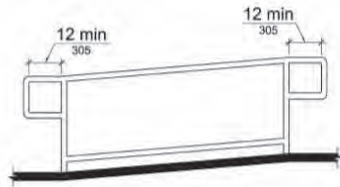

**FIGURE 505.10.1 TOP AND BOTTOM HANDRAIL EXTENSION AT RAMPS**

**505.10.2 Top Extension at Stairs.**

At the top of a stair flight, handrails shall extend horizontally above the landing for 12 inches (305 mm) minimum beginning directly above the first riser nosing. Extensions shall return to a wall, guard, or the landing surface, or shall be continuous to the handrail of an adjacent stair flight.

**202.5 Alterations to Qualified Historic Buildings and Facilities.**

*Alterations to a qualified historic building or facility shall comply with 202.3 and 202.4 to the maximum extent feasible.*

**EXCEPTION:** Where the State Historic Preservation Officer or Advisory Council on Historic Preservation determines that compliance with the requirements for *accessible routes, entrances, or toilet facilities* would threaten or destroy the historic significance of the *building or facility*, the exceptions for *alterations to qualified historic buildings or facilities* for that *element* shall be permitted to apply.

**Advisory 202.5 Alterations to Qualified Historic Buildings and Facilities Exception.** State Historic Preservation Officers are State appointed officials who carry out certain responsibilities under the National Historic Preservation Act. State Historic Preservation Officers consult with Federal and State agencies, local governments, and private entities on providing access and protecting significant elements of qualified historic buildings and facilities. There are exceptions for alterations to qualified historic buildings and facilities for accessible routes (206.2.1, Exception 1 and 206.2.3, Exception 7); entrances (206.4, Exception 2); and toilet facilities (213.2, Exception 2). When an entity believes that compliance with the requirements for any of these elements would threaten or destroy the historic significance of the building or facility, the entity should consult with the State Historic Preservation Officer. If the State Historic Preservation Officer agrees that compliance with the requirements for a specific element would threaten or destroy the historic significance of the building or facility, use of the exception is permitted. Public entities have an additional obligation to achieve program accessibility under the Department of Justice ADA regulations. See 28 CFR 35.150. These regulations require public entities that operate historic preservation programs to give priority to methods that provide physical access to individuals with disabilities. If alterations to a qualified historic building or facility to achieve program accessibility would threaten or destroy the historic significance of the building or facility, fundamentally alter the program, or result in undue financial or administrative burdens, the Department of Justice ADA regulations allow alternative methods to be used to achieve program accessibility. In the case of historic preservation programs, such as an historic house museum, alternative methods include using audio-visual materials to depict portions of the house that cannot otherwise be made accessible. In the case of other qualified historic properties, such as an historic government office building, alternative methods include relocating programs and services to accessible locations. The Department of Justice ADA regulations also allow public entities to use alternative methods when altering qualified historic buildings or facilities in the rare situations where the State Historic Preservation Officer determines that it is not feasible to provide physical access using the exceptions permitted in Section 202.5 without threatening or destroying the historic significance of the building or facility. See 28 CFR 35.151(d).

The Accessibility Office at the National Endowment for the Arts (NEA) provides a variety of resources for museum operators and historic properties including: the Design for Accessibility Guide and the Disability Symbols. Contact NEA about these and other resources at 202-682-5532 or [www.arts.gov](http://www.arts.gov).

**504.5 Nosings.**

The radius of curvature at the leading edge of the tread shall be 1/2 inch (13 mm) maximum. Nosings that project beyond risers shall have the underside of the leading edge curved or beveled. Risers shall be permitted to slope under the tread at an angle of 30 degrees maximum

from vertical. The permitted projection of the nosing shall extend 1½ inches (38 mm) maximum over the tread below.

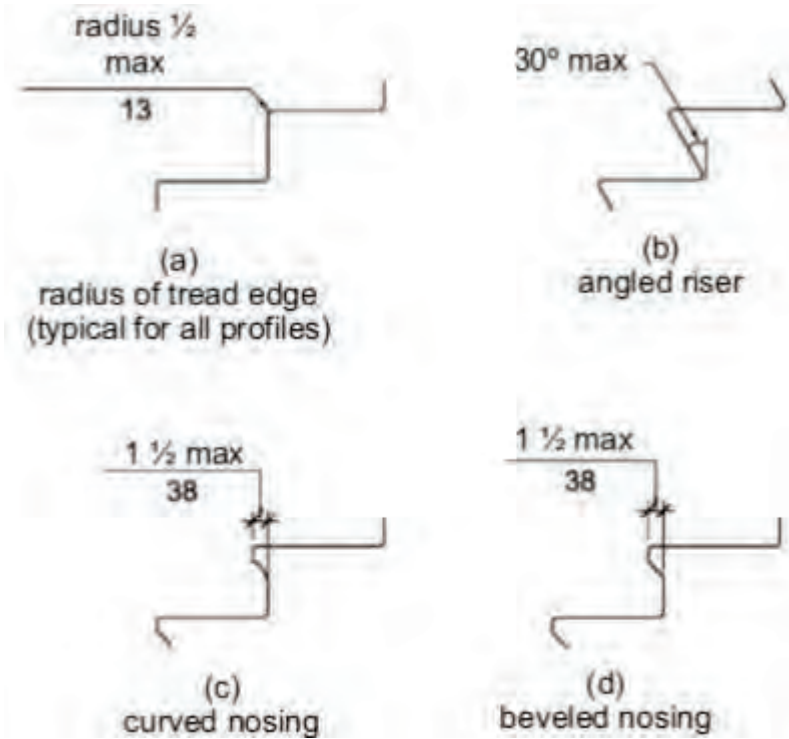

**FIGURE 504.5  
 STAIR NOSINGS**

**END OF REPORT**