

SOLICITATION - OFFER - AWARD

SOLICITATION NO: 23-CG0215/JG	SOLICITATION TITLE: DR. DENNIS WILFONG CENTER FOR SUCCESS/INFRASTRUCTURE - REBID	DATE ISSUED: MARCH 8, 2023	CONTRACT NO: 23-CG0215/JG
ISSUED BY: BOARD OF COUNTY COMMISSIONERS HERNANDO COUNTY, FLORIDA John Allocco, Chairman Elizabeth Narverud, Vice Chairman Steve Champion, Second Vice Chairman Jerry Campbell Brian Hawkins		SUBMIT BID OFFER TO: HERNANDO COUNTY PROCUREMENT DEPARTMENT 15470 FLIGHT PATH DRIVE BROOKSVILLE, FL 34604 Toni Brady Chief Procurement Officer	

SOLICITATION

SEALED OFFERS, FOR FURNISHING THE SERVICES, SUPPLIES OR EQUIPMENT DESCRIBED HEREIN WILL BE RECEIVED AT THE OFFICE OF PROCUREMENT DEPARTMENT, VIA HERNANDO COUNTY'S EPROCUREMENT PORTAL AT: <http://secure.orccurenw.com/portal/hernandocounty>. ON **APRIL 10, 2023**. NO BID OFFERS WILL BE ACCEPTED AFTER THE ABOVE STIPULATED DATE AND TIME. THIS IS AN ADVERTISED SOLICITATION AND THE RESPONDING BIDDERS WILL BE PUBLICLY READ IN THE PROCUREMENT DEPARTMENT CONFERENCE ROOM AT **10:00 A.M. ON APRIL 10, 2023**. PURSUANT TO FS 119.071 (current version), SEALED BIDS, PROPOSALS, OR REPLIES RECEIVED BY AN AGENCY PURSUANT TO A COMPETITIVE SOLICITATION ARE EXEMPT FROM FINAL INSPECTION UNTIL SUCH TIME AS THE AGENCY PROVIDES NOTICE OF AN INTENDED DECISION OR UNTIL THIRTY (30) DAYS AFTER OPENING THE BIDS, PROPOSALS, OR FINAL REPLIES, WHICHEVER IS EARLIER.

ITEM NO.	DESCRIPTION OF SERVICE/SUPPLIES/EQUIPMENT	QTY	UNIT	UNIT PRICE	TOTAL AMOUNT
1	The Vendor/Contractor will supply all materials, labor, and equipment in order to accomplish the DR. DENNIS WILFONG CENTER FOR SUCCESS/INFRASTRUCTURE - REBID , as described in the specifications and construction plans showing the proposed improvements in Hernando County, Florida. <small>(SEE ATTACHED SPECIFICATIONS)</small>	1	XXXXX	XXXXXXXXXX	\$ <u>1,894,666.20</u>

OFFER

(TERMS, CONDITIONS AND SPECIFICATIONS ARE INCLUDED AS PARTS HEREOF)

IN COMPLIANCE WITH THE ABOVE, THE UNDERSIGNED, BEING DULY AUTHORIZED TO SIGN THIS BID FOR THE BIDDER, AGREES THAT IF THIS OFFER IS ACCEPTED WITHIN **ONE HUNDRED TWENTY (120) DAYS** FROM THE BID OPENING DATE, TO FURNISH TO HERNANDO COUNTY ANY AND ALL ITEMS FOR WHICH PRICES ARE OFFERED IN THIS BID SOLICITATION AT THE PRICE(S) SO OFFERED, DELIVERED AT DESIGNATED POINT(S), WITHIN THE TIME PERIOD SPECIFIED, AND AT THE TERMS AND CONDITIONS SO STIPULATED IN THE SOLICITATION FOR BIDS.

DISCOUNT FOR PROMPT PAYMENT: _____ % 10 CALENDAR DAYS _____ % 20 CALENDAR DAYS _____ % _____ CALENDAR DAYS	
BIDDER'S INFORMATION Goodwin Bros Construction, Inc. Company Name 14341 Ponce De Leon Blvd Address Brooksville FL 34601 City State Zip Code 352-796-0149 352-544-1084 estimator@goodwinbrosinc.com Phone Number Fax Number Email Address	NAME AND TITLE OF PERSON AUTHORIZED TO SIGN BID OFFER BIDDER'S SIGNATURE  OFFER DATE 4/10/2023

AWARD

(TO BE COMPLETED BY COUNTY)

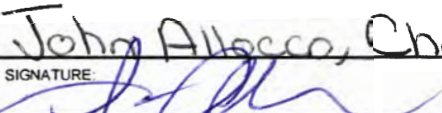
REVIEWED FOR LEGAL SUFFICIENCY: 01/17/2023	LR NO.: 2023-18-1	BY: Victoria Anderson
ACCEPTED AS TO ITEM(S) NO.	AMOUNT:	ACCOUNTING CODE:
SUBMIT INVOICES TO: Board of County Commissioners of Hernando County, Florida 15470 Flight Path Drive Brooksville, FL 34604	NAME AND TITLE OF PERSON AUTHORIZED TO SIGN ACCEPTANCE AND AWARD FOR THE COUNTY: John Allocco, Chairman	
	SIGNATURE: 	AWARD DATE: 5/9/2023



**BOARD OF COUNTY COMMISSIONERS
HERNANDO COUNTY, FLORIDA
CONSTRUCTION AGREEMENT**

This Contract, entered into this 9th day of May, 2023, by and between the Hernando County Board of County Commissioners, hereafter called the COUNTY, and Goodwin Bros. Construction, Inc., hereinafter called the VENDOR/CONTRACTOR. Owner and Vendor/Contractor, in consideration of the mutual covenants hereinafter set forth, agree as follow:

DR. DENNIS WILFONG CENTER FOR SUCCESS/INFRASTRUCTURE - REBID

ITB NO. 23-CG0215/JG

BROOKSVILLE, FLORIDA

ARTICLE 1 – CONTRACT DOCUMENTS

1.01 The Vendor/Contractor shall furnish all labor, equipment and materials and perform the work above described for the amount stated above in strict accordance with the General Conditions, Special Conditions, Supplementary Conditions, Exhibits, Plans, Specifications, and other Contract Documents, all of which are made a part hereof and designated as follows:

1.01.1 The Contract Documents for Bid No. 23-CG0215/JG consist of the following:

Solicitation-Offer-Award	General Requirements and Technical Specifications
Advertisement of Bid	Bid/Proposal Pricing
Solicitation Instructions	Required Forms and Certifications
General Conditions	Construction Agreement and Required Documents After Award
Special Conditions	Attachments/Reference Documents
Supplementary Conditions for Federal/State Requirements	Exhibit A – Plans/Drawings
Scope and Specifications	Exhibit B – Geological Report

All addenda issued by the County prior to the receipt of bids and all supplementary drawings issued after award of the Contract become part of the Contract Document.

Amending and Supplementing Contract Documents:

The Contract Documents may be amended to provide for additions, deletions, and revisions in the work or to modify the terms and conditions thereof by Change Order.

The requirements of the Contract Documents may be supplemented, and minor variations and deviations in the work may be authorized, by one (1) or more of the following ways:

1. A Field Order;
2. Engineer's approval of a shop drawing or sample; or

3. Engineer's written interpretation or clarification per the provisions described in the Contract Documents.

In resolving such conflicts, errors and discrepancies, the documents shall be given preference in the following order: Agreement, Specifications, Drawings, Solicitation Instructions. Within the specifications the order of preference shall be as follows: Addenda, General Conditions, Technical Specifications. Figure dimensions on drawings shall govern over scale dimensions, and the detailed drawings shall govern over general drawings. Any work that may reasonably be inferred from the specifications or drawings as being required to produce the intended result shall be supplied whether or not it is specifically called for. Work materials or equipment described in words which so applied have a well-known technical or trade meaning shall be deemed to refer to such recognized standards. In case of conflict the more stringent requirements shall take precedence and govern.

The Vendor/Contractor shall take no advantage of any error or omission in the plans or of any discrepancy between the plans and specifications, and the Engineer shall make such interpretation as may be deemed necessary for the fulfillment of the intent of the plans and specifications as construed by him and his decision shall be final.

All provisions required by law to be inserted in this Contract, whether actually inserted or not.

Exhibits to this Agreement (as follows):

1. Vendor/Contractor's Bid
 2. Documentation submitted by Vendor/Contractor after the Notice of Award:
 - a. Insurance Certificate
 - b. Payment and Performance Bond
- 1.02** The following which may be delivered or issued on or after the Effective Date of the Agreement and are not attached hereto:
1. Notice to Proceed
 2. Change Order(s)
- 1.03** The documents listed in the Article are attached to this Agreement (except as expressly noted otherwise).
- 1.04** There are no Contract Documents other than those listed in this Article
- 1.05** The Contract Documents may only be amended, modified, or supplemented as stated in solicitation Section Titled "SPECIAL CONDITIONS", paragraph 16. Titled "Changes in the Work; Claims".

ARTICLE 2 - THE ENGINEER

- 2.01** Engineer in the administration of this Contract and any references to the Engineer or the Professional shall be deemed to mean **Brian M. Malmberg, P.E., Coastal Engineering Associates, Inc.**, for the plans and specifications. **Erik van de Boogaard, Hernando County Construction Projects Coordinator** will act as the Owner's representative, assume all duties and responsibilities, and have the rights and authority assigned to Engineer in the Contract Documents in connection with the completion of the work in accordance with their respective scope of work and the Contract Documents.

ARTICLE 3 – CONTRACT TIMES

3.01 Time of the Essence:

3.01.1 All time limits for completion and readiness for final payment as stated in the Contract Documents are of the essence of the Contract.

3.02 Days to Achieve Substantial Completion and Final Payment:

3.02.1 Vendor/Contractor agrees that the work will be substantially complete within **one hundred eighty (180)** calendar days after the commencement date indicated in the Notice to Proceed and ready for final payment within **one hundred ninety-four (194)** calendar days after the date indicated on the Notice to Proceed.

3.03 Liquidated Damages:

Vendor/Contractor and Owner agree for each consecutive calendar day that the work remains incomplete after the Contract date established for Substantial Completion and/or Final Completion, the County will retain from the compensation otherwise to be paid to the Vendor/Contractor the sum of **four hundred (\$400.00) per day**. This amount is the minimum measure of damages the County will sustain by failure of the Vendor/Contractor to complete all remedial work, correct deficient work, clean up the project and other miscellaneous tasks as required to complete all work specified.

ARTICLE 4 – CONTRACT PRICE

4.01 Owner shall pay Vendor/Contractor for completion of the work in accordance with the Contract Documents an amount in current funds equal to the sum of the amounts determined pursuant to the paragraphs below:

4.01.1 For all work other than unit price work, a Lump Sum of:

<u>One Million, Eight Hundred Ninety-Four Thousand, Six Hundred Sixty-Six and 20/100</u>	<u>(\$1,894,666.20)</u>
(words)	(figure)

All specific cash allowances are included in the above price and have been computed in accordance with solicitation Section Titled "SPECIAL CONDITIONS", paragraph 17. Titled "Cost of the Work; Allowances; Unit Price Work", subparagraph B. titled "Allowances" item no. 2. Titled "Cash Allowances".

4.01.2 For all unit price work, an amount equal to the sum of the established unit price for each separately identified item of unit price work times the estimated quantity of that item as indicated in this Paragraph:

As provided in solicitation Section Titled "SPECIAL CONDITIONS", paragraph 17. Titled "Cost of the Work; Allowances; Unit Price Work", subparagraph C. titled "Unit Price Work", estimated quantities are not guaranteed, and determinations of actual quantities and classifications are to be made by Owner Designated Representative as provided in solicitation Section Titled "SPECIAL CONDITIONS", paragraph 17. Titled "Cost of the Work; Allowances; Unit Price Work", subparagraph C. titled "Unit Price Work". Unit prices have been computed as provided in solicitation Section Titled "SPECIAL CONDITIONS", paragraph 17. Titled "Cost of the Work; Allowances; Unit Price Work", subparagraph C. titled "Unit Price Work".

UNIT PRICE WORK

GENERAL CONDITIONS

Line Item	Description	Quantity	Unit of Measure	Unit Cost	Total
1	Mobilization	1	LS	\$23,575.00	\$23,575.00
2	Insurance, Permits, and Performance & Payment Bond	1	LS	\$23,365.00	\$23,365.00
3	Maintenance of Traffic	1	LS	\$3,450.00	\$3,450.00
4	Survey Layout/As-built	1	LS	\$28,129.00	\$28,129.00
5	Pre/Post Video	1	LS	\$575.00	\$575.00
6	Erosion Sediment Control (includes NPDES Permit/Inspection Report/NOT	1	LS	\$1,725.00	\$1,725.00
TOTAL					\$80,819.00

CLEARING, GRUBBING AND EARTHWORK

Line Item	Description	Quantity	Unit of Measure	Unit Cost	Total
7	Clearing/Grubbing (includes DRA & Floodplain Comp)	20	AC	\$3,910.00	\$78,200.00
8	Embankment Excavation, Filling and Grading	1	LS	\$75,977.78	\$75,977.78
9	Temporary Construction Access	1	LS	\$1,060.00	\$1,060.00
10	Silt Fence Installation and Removal	5,800	LF	\$1.32	\$7,656.00
TOTAL					\$162,893.78

STORM DRAINAGE

Line Item	Description	Quantity	Unit of Measure	Unit Cost	Total
11	15" RCP	68	LF	\$56.22	\$3,822.96
12	18" RCP	508	LF	\$60.40	\$30,683.20
13	24" RCP	92	LF	\$86.53	\$7,960.76
14	29" x 45" ERCP	104	LF	\$244.49	\$25,426.96
15	30" RCP	266	LF	\$128.21	\$34,103.86
16	42" RCP	266	LF	\$216.80	\$57,668.80
17	48" RCP	334	LF	\$263.40	\$87,975.60
18	FDOT Gutter Type V Inlet	6	EA	\$5,298.13	\$31,788.78
19	FDOT Type C Inlet	1	EA	\$3,349.02	\$3,349.02
20	FDOT Type F Inlet	2	EA	\$10,516.58	\$21,033.16
21	FDOT Type G Inlet	1	EA	\$8,386.58	\$8,386.58
22	FDOT Type 7 Inlet	1	EA	\$8,011.28	\$8,011.28
23	24" MES	3	EA	\$902.75	\$2,708.25
24	29" x 45" MES	2	EA	\$4,110.10	\$8,220.20
25	48" MES	1	EA	\$5,709.75	\$5,709.75
26	Rip Rap	650	SF	\$5.52	\$3,588.00
27	Concrete Weir with Skimmer	1	EA	\$12,150.95	\$12,150.95

Line Item	Description	Quantity	Unit of Measure	Unit Cost	Total
28	Sod DRA Side Slopes	13,800	SY	\$2.65	\$36,570.00
29	Seed and Mulch DRA	56,000	SY	\$0.30	\$16,800.00
TOTAL					\$405,958.11

SANITARY SEWER

Line Item	Description	Quantity	Unit of Measure	Unit Cost	Total
30	8" PVC SDR 26 (0'-6')	350	LF	\$52.13	\$18,245.50
31	8" PVC SDR 26 (6'-8')	350	LF	\$57.88	\$20,258.00
32	8" PVC SDR 26 (8'-10')	222	LF	\$60.42	\$13,413.24
33	Manholes (0'-6')	2	EA	\$6,616.28	\$13,232.56
34	Manholes (6'-8')	1	EA	\$8,339.71	\$8,339.71
35	Manholes (8'-10')	1	EA	\$9,803.75	\$9,803.75
36	LS Receiving Manhole (8'-10') Coated	1	EA	\$14,137.39	\$14,137.39
37	Pump Station Complete	1	LS	\$460,000.00	\$460,000.00
38	Gravity Sewer Testing	922	LF	\$9.05	\$8,344.10
39	4" PVC C-900 Force Main	1,840	LF	\$24.75	\$45,540.00
40	4" MJ 45 Ftg with Restraints	10	EA	\$666.61	\$6,666.10
41	4" x 6" Tapping Sleeve and Valve	1	EA	\$7,506.83	\$7,506.83
42	Force Main Pressure Testing	1,840	LF	\$2.88	\$5,299.20
43	Stabilized Roadway	930	SY	\$10.56	\$9,820.80
TOTAL					\$640,607.18

WATER DISTRIBUTION

Line Item	Description	Quantity	Unit of Measure	Unit Cost	Total
44	8" PVC C-900 Water Main	100	LF	\$75.67	\$7,567.00
45	12" PVC C-900 Water Main	1,150	LF	\$104.42	\$120,083.00
46	12" MJ 45 Ftg with Restraints	4	EA	\$2,107.63	\$8,430.52
47	12" x 4" Tee Ftg with Restraints	3	EA	\$1,331.11	\$3,993.33
48	12" x 8" Tee Ftg with Restraints	3	EA	\$1,461.97	\$4,385.91
49	12" x 8" Cross Ftg with Restraints	1	EA	\$1,645.65	\$1,645.65
50	4" Gate Valve with Restraints	3	EA	\$2,542.75	\$7,628.25
51	8" Gate Valve with Restraints	5	EA	\$4,132.79	\$20,663.95
52	12" Gate Valve with Restraints	2	EA	\$7,130.00	\$14,260.00
53	4" End Cap with Restraints	3	EA	\$286.30	\$858.90
54	8" End Cap with Restraints	3	EA	\$445.91	\$1,337.73
55	Temporary Water Service Connection (HCUD Detail #42)	1	EA	\$1,725.00	\$1,725.00
56	Cut and Connect to Existing Water Main	4	EA	\$8,674.07	\$34,696.28
57	Water Testing/Chlorination	1,250	LF	\$4.27	\$5,337.50

Line Item	Description	Quantity	Unit of Measure	Unit Cost	Total
TOTAL					\$232,613.02

ROAD CONSTRUCTION

Line Item	Description	Quantity	Unit of Measure	Unit Cost	Total
58	12" Type B Stabilized Subgrade	2,920	SY	\$2.95	\$8,614.00
59	8" Limerock Base	2,920	SY	\$13.35	\$38,982.00
60	1-5" Type SP-12.5 Asphalt (Traffic Level C)	2,920	SY	\$10.17	\$29,696.40
61	1" Type SP-9.5 Asphalt (Traffic Level C)	2,920	SY	\$6.90	\$20,148.00
62	Drop Curb	1,100	LF	\$15.53	\$17,083.00
63	Valley Gutter	130	LF	\$28.75	\$3,737.50
64	Sod R/W	7,600	SY	\$2.65	\$20,140.00
65	5' Concrete Sidewalk (3,000 psi/4" thick)	19,332	SF	\$7.48	\$144,603.36
66	Curb Ramp with Tactile Surface	4	EA	\$747.50	\$2,990.00
67	10' x 10' Concrete Pad (3,000 psi/4" thick)	2	EA	\$977.50	\$1,955.00
68	Seed and Mulch R/W, Easements	8,900	SY	\$0.30	\$2,670.00
69	Striping/Signage	1	LS	\$6,376.75	\$6,376.75
TOTAL					\$296,996.01

GOPHER TORTOISE RELOCATION

Line Item	Description	Quantity	Unit of Measure	Unit Cost	Total
70	Gopher Tortoise Survey & Permitting	1	LS	\$3,268.30	\$3,268.30
71	Gopher Tortoise Burrow Excavation	18	EA	\$230.00	\$4,140.00
72	Gopher Tortoise Relocation	10	EA	\$6,737.08	\$67,370.80
TOTAL					\$74,779.10

ESTIMATED TOTAL OF ALL UNIT PRICE WORK

\$ One Million, Eight Hundred
Ninety-Four Thousand, Six
Hundred Sixty-Six and 20/100
(use words) \$(1,894,666.20)
(figure)

ARTICLE 5 – PAYMENT PROCEDURES

5.01 Submittal and Processing of Payments:

- 5.01.1** Vendor/Contractor shall submit Applications for Payment in accordance with solicitation Section Titled "SPECIAL CONDITIONS", paragraph 21. Titled "Payments to Contractor and Completion", subparagraph B. titled "Progress Payments", subparagraph 1 titled "Application for Payments"; item A. Applications for Payment will be processed by Owner Designated Representative as provided in the Contract Documents.

5.02 Progress Payments: Retainage:

5.02.1 Owner shall make progress payments on account of the Contract Price on the basis of Vendor/Contractor's Applications for Payment not later than the time periods established by applicable provisions of the Florida Prompt Payment Act, Part VII, Ch. 218.735, F.S. (current version), during performance of the work as provided in paragraphs below. All such payments will be measured by the Schedule of Values (and in the case of unit price work based on the number of units completed) or, in the event there is no schedule of values, as provided in the General Requirements:

5.02.1.1 Progress payments will be made in an amount equal to the percentage indicated below but, in each case, less the aggregate of payments previously made and less such amounts as Owner Designated Representative may determine or Owner may withhold, including but not limited to liquidated damages, in accordance with the Contract Documents:

5.02.1.1.1 Ninety-five percent (95%) of work completed (with the balance being retainage); and

5.02.1.1.2 Ninety-five percent (95%) of cost of materials and equipment not incorporated in the work (with the balance being retainage).

5.03 Final Payment:

5.03.1 Upon receipt of the final Application for Payment accompanied by Owner Designated Representative's recommendation of payment in accordance with solicitation Section Titled "SPECIAL CONDITIONS", paragraph 21. Titled "Payments to Contractor and Completion", subparagraph B. titled "Progress Payments", subparagraph 1 titled "Application for Payments:", item A, Owner shall pay Vendor/Contractor the remainder of the Contract Price as recommended by Owner Designated Representative, less any sum Owner is entitled to set off against Owner Designated Representative's recommendation, including but not limited to liquidated damages.

5.03.2 Final Payment, constituting the entire unpaid balance of the Contract Sum, shall be paid by the Owner to the Vendor/Contractor when the work has been completed, the Contract fully performed, NPDES – FDEP Notice of Termination (NOT) has been delivered to the Owner Designated Representative and a final Certificate for Payment has been issued by the Owner Designated Representative.

ARTICLE 6 – INTEREST

6.01 All moneys not paid when due shall bear interest at the maximum legal rate.

ARTICLE 7 – VENDOR/CONTRACTOR'S REPRESENTATIONS

7.01 In order to induce Owner to enter into this Agreement Vendor/Contractor makes the following representations:

7.01.1 Vendor/Contractor has examined and carefully studied the Contract Documents and the other related data identified in the Bid Documents.

7.01.2 Vendor/Contractor has visited the site and become familiar with and is satisfied as to the general, local, and site conditions that may affect cost, progress, and performance of the work.

7.01.3 Vendor/Contractor is familiar with and is satisfied as to all Federal, State, and local laws and regulations that may affect cost, progress, and performance of the work.

7.01.4 Vendor/Contractor does not consider that any further examinations, investigations, explorations, tests, studies, or data are necessary for the performance of the work at the

Contract Price, within the Contract Times, and in accordance with the other terms and conditions of the Contract Documents.

- 7.01.5 Vendor/Contractor is aware of the general nature of work to be performed by Owner and others at the site that relates to the work as indicated in the Contract Documents.
- 7.01.6 Vendor/Contractor has correlated the information known to Vendor/Contractor, information and observations obtained from visits to the site, reports and drawings identified in the Contract Documents, and all additional examinations, investigations, explorations, tests, studies, and data with the Contract Documents.
- 7.01.7 Vendor/Contractor has given Engineer written notice of all conflicts, errors, ambiguities, or discrepancies that Vendor/Contractor has discovered in the Contract Documents, and the written resolution thereof by Engineer is acceptable to Vendor/Contractor.
- 7.01.8 The Contract Documents are generally sufficient to indicate and convey understanding of all terms and conditions for performance and furnishing of the work.

ARTICLE 8 – MISCELLANEOUS

8.01 Terms:

- 8.01.1 Terms used in this Agreement will have the meanings stated in the Contract Documents.

8.02 Assignment of Contract:

- 8.02.1 No assignment by a party hereto of any rights under or interests in the Contract will be binding on another party hereto without the written consent of the party sought to be bound; and, specifically but without limitation, moneys that may become due and moneys that are due may not be assigned without such consent (except to the extent that the effect of this restriction may be limited by law), and unless specifically stated to the contrary in any written consent to an assignment, no assignment will release or discharge the assignor from any duty or responsibility under the Contract Documents.

8.03 Severability:

- 8.03.1 Any provision or part of the Contract Documents held to be void or unenforceable under any law or regulation shall be deemed stricken, and all remaining provisions shall continue to be valid and binding upon Owner and Vendor/Contractor, who agree that the Contract Documents shall be reformed to replace such stricken provision or part thereof with a valid and enforceable provision that comes as close as possible to expressing the intention of the stricken provision.

- 8.04 This Agreement may be executed in several counterparts, each of which shall be an original and all of which shall constitute but one (1) and the same instrument.

ARTICLE 9 – CONTRACT PAYMENT

- 9.01 The County agrees to pay the Vendor/Contractor for the faithful performance under this Contract for the agreed amount of One Million, Eight Hundred Ninety-Four Thousand, Six Hundred Sixty-Six and 20/100 Dollars (\$1,894,666.20) and is based on the lump sum prices contained herein and subject to additions or deductions as modified.

OWNER:
HERNANDO COUNTY BOARD OF COUNTY
COMMISSIONERS

By: JOHN ALLOCCO

Title: CHAIRMAN

[CORPORATE SEAL]

Heidi Kuppe, Deputy Clerk

Attest: Douglas A. Chorvat, Jr.

Title: Clerk of Circuit Court & Comptroller

Address for giving notices:

15470 Flight Path Dr.

Brooksville, FL 34604

VENDOR/CONTRACTOR

GOODWIN BROS. CONSTRUCTION, INC.

By: DANIEL RAY GOODWIN, JR.

Title: PRESIDENT

[CORPORATE SEAL]

Toro Chavira

Attest: _____

Title: PROJECT MANAGER / ESTIMATOR

Address for giving notices:

P.O. Box 1689

Brooksville, FL 34605-1689

Agent for service of process:

(If Vendor/Contractor is a corporation or a partnership,
attach evidence of authority to sign.)

CONSTRUCTION PLANS for DR DENNIS WILFONG CENTER FOR SUCCESS

PROJECT AREA: 20.0 ACRES ±
HERNANDO COUNTY, FLORIDA

OWNER/APPLICANT: HERNANDO COUNTY BOARD OF COUNTY COMMISSIONERS
1525 EAST JEFFERSON STREET
BROOKSVILLE, FL 34601
PH: (352) 754-4096 X17037
CONTACT: ERIC VAN DE BOOGAARD
EMAIL: EvanDeBoogaard@co.hernando.fl.us

ENGINEER: COASTAL ENGINEERING ASSOC., INC.
966 CANDLELIGHT BLVD.
BROOKSVILLE, FLA. 34601
PH: (352) 796-9423
CONTACT: BRIAN MALMBERG
EMAIL: bmalMBERG@coastal-engineering.com

SURVEYOR: COASTAL ENGINEERING ASSOC., INC.
966 CANDLELIGHT BLVD.
BROOKSVILLE, FLA. 34601
PH: (352) 796-9423
CONTACT: BRIAN MALMBERG
EMAIL: bmalMBERG@coastal-engineering.com

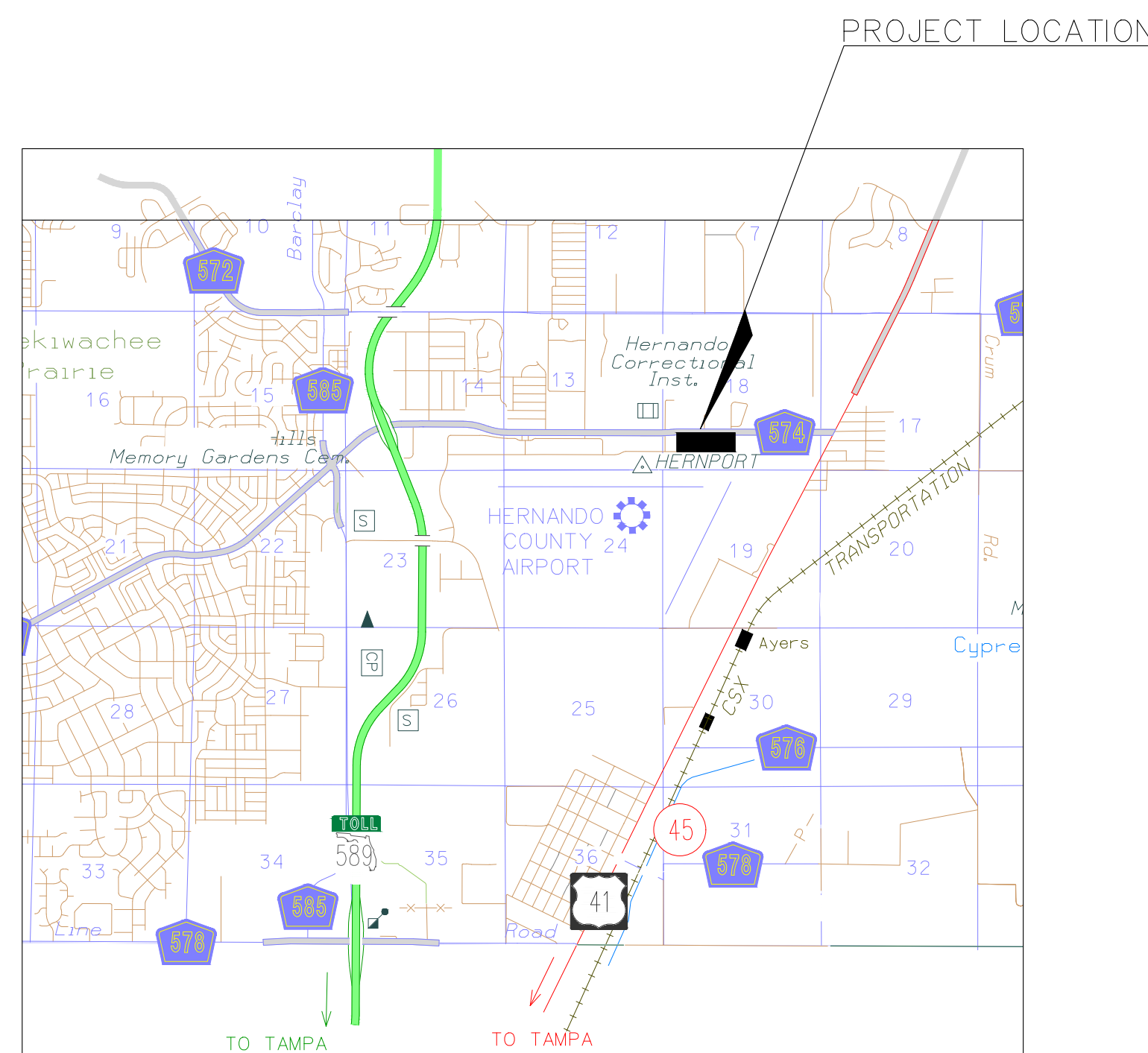

Project Number 21115

PREPARED FOR:

HERNANDO COUNTY BOARD OF COUNTY COMMISSIONERS
1525 EAST JEFFERSON STREET
BROOKSVILLE, FL 34601
(352) 754-4096 X17037

PREPARED BY:

Coastal Engineering
Planning
Surveying
Environmental
Construction Management
engineering associates, inc.
966 Candlelight Boulevard - Brooksville - Florida 34601
(352) 796-9423 - Fax (352) 799-8359
EB-0000142

Sheet List Table

- C-01 Cover Sheet
 - C-02 General Notes and Specifications
 - C-03 Existing Conditions Plan
 - C-04 Master Site Plan
 - C-05 Grading, Drainage and Paving Plan
 - C-06 Pond NE0580 Modifications
 - C-07 Pond ND1000 Modifications (1)
 - C-08 Pond ND1000 Modifications (2)
 - C-09 Pond Cross Sections
 - C-10 Helicopter Drive Plan Profile
 - C-11 Access Road Plan Profile
 - ** C-12 Master Utility Plan
 - ** C-13 Utility Plan Profile
 - ** C-14 Lift Station Details (1)
 - ** C-15 Lift Station Details (2)
 - C-16 Drainage and Paving Details 1
 - C-17 Drainage and Paving Details 2
 - ** C-18 Utility Details 1
 - ** C-19 Utility Details 2
 - C-20 SWPP Notes
 - C-21 SWPP Details
 - C-22 Pre-Development Drainage Map
 - C-23 POST DEVELOPMENT DRAINAGE MAP
- ** PAGES NOT INCLUDED IN SWFWMD SUBMITTAL

BID SET 09/13/2022
REV 2 - 10/17/2022
REV 3 - 10/27/2023

PLAN REVISIONS

AGENCY APPROVALS

DATE	REVISION NO.	REVISION	AGENCY	PERMIT TYPE	PERMIT NO.	EXP. DATE
09/13/22	1	BID SET				
10-13-22	2	ADDRESS HCUD COMMENTS ADJUST UTIL/STORM LOCATIONS ON SH DRIVE				
1-24-23	3	ADDRESS HCUD COMMENTS, ADD ALT BID SIDEWALK				

Brian M. Malmberg, State of Florida, Professional Engineer, License No. 59405. This item has been digitally signed and sealed by Brian M. Malmberg on the date indicated here. Printed copies of this document are not considered signed and sealed and the signature must be verified on any electronic copies.

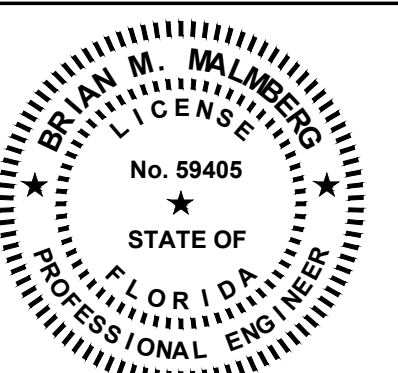

DESIGN ENGINEER BRIAN M. MALMBERG, P.E., REGISTRATION NO. 59405



DESCRIPTION

A TRACT OR PARCEL OF LAND LYING IN THE SOUTHWEST QUARTER OF SECTION 18, TOWNSHIP 23 SOUTH, RANGE 19 EAST, HERNANDO COUNTY, FLORIDA, BEING MORE PARTICULARLY DESCRIBED AS FOLLOWS:

FOR A POINT OF REFERENCE, COMMENCE AT THE SOUTHWEST CORNER OF SECTION 18, TOWNSHIP 23 SOUTH, RANGE 19 EAST, HERNANDO COUNTY, FLORIDA THENCE N.00°17'02"E., ALONG THE WEST LINE OF THE SOUTHWEST QUARTER OF SAID SECTION 18, A DISTANCE OF 661.60 FEET TO A POINT ON THE CENTERLINE OF HELICOPTER DRIVE, THENCE S.89°50'19"E., ALONG THE CENTERLINE OF SAID HELICOPTER DRIVE, A DISTANCE OF 355.13 FEET, THENCE N.00°09'41"E., A DISTANCE OF 30.00 FEET, TO THE POINT OF BEGINNING, THENCE N.00°16'15"E., ALONG THE EAST LINE OF LANDS DESCRIBED IN OFFICIAL RECORDS BOOK 1304, PAGE 166, PUBLIC RECORDS HERNANDO COUNTY, FLORIDA A DISTANCE OF 458.59 FEET, THENCE S.89°48'23"E., A DISTANCE OF 253.42 FEET, THENCE N.00°06'34"E. A DISTANCE OF 125.19 FEET TO A POINT ON THE SOUTHERLY RIGHT OF WAY LINE OF SPRING HILL DRIVE, THENCE S.89°53'26"E., ALONG SAID SOUTHERLY RIGHT OF WAY LINE, A DISTANCE OF 1,138.19 FEET, THENCE S00°08'41"W., DEPARTING SAID RIGHT OF WAY LINE, A DISTANCE OF 584.67 FEET, THENCE N.89°50'19"W., A DISTANCE OF 1,392.54 FEET, TO THE POINT OF BEGINNING OF THE HEREIN DESCRIBED PARCEL.

PARCEL CONTAINS 781,264.8 SQUARE FEET OR 17.94 ACRES, MORE OR LESS.

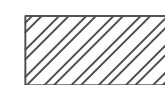
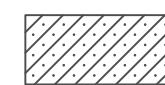

FLOOD ZONE LEGEND

-  = FLOOD ZONE X (AREAS DETERMINED TO FALL OUTSIDE OF THE 0.2% CHANCE ANNUAL FLOODPLANE)
-  = FLOOD ZONE AE (HAVING A BASE FLOOD ELEVATION OF 66.10 FEET)
-  = FLOOD ZONE AE (HAVING A BASE FLOOD ELEVATION OF 67.20 FEET)
-  = FLOOD ZONE AE (HAVING A BASE FLOOD ELEVATION OF 66.40 FEET)
-  = FLOOD ZONE A (HAVING NOT BEEN ASSIGNED A BASE FLOOD ELEVATION)

SURVEYORS NOTE:
THE FLOOD ZONE SEPARATION LINE SHOWN HEREON WAS SCALED FROM A DIGITAL IMAGE OF THE FIRM MAP, COMMUNITY PANEL NUMBER AS INDICATED HEREON AND IS AN APPROXIMATE LOCATION ONLY.

FEMA NOTE:
THE PROPERTY DESCRIBED HEREON APPEARS TO BE IN FLOOD ZONE "X" (AREA DETERMINED TO FALL OUTSIDE OF THE 0.2% CHANCE ANNUAL FLOODPLANE); FLOOD ZONE "AE" (BASE FLOOD ELEVATION 66.10'); FLOOD ZONE "AE" (BASE FLOOD ZONE 67.20'); FLOOD ZONE "AE" (BASE FLOOD ELEVATION 66.40') AND FLOOD ZONE "A" (NO BASE FLOOD ELEVATION DETERMINED) AS SCALED FROM THE FLOOD INSURANCE RATE MAP COMMUNITY NUMBER 120110, MAP NUMBER 12053C, PANEL NUMBER 0327-D, EFFECTIVE DATE 02/02/2012.

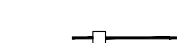
LEGEND:

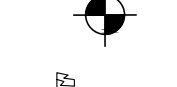
-  PROPOSED SILT FENCE LOCATION
-  TREE TO BE REMOVED
-  GEOTECHNICAL TEST LOCATION
-  GOPHER TORTOISE BURROW LOCATOR

GOPHER TORTOISE NOTES:

1. GOPHER TORTOISE BURROWS IDENTIFIED DURING FEB. 11, 2021 SURVEY.
2. CONTRACTOR TO PROVIDE UPDATED GOPHER TORTOISE SURVEY AND FWC RELOCATION PERMIT FOR ENTIRE 17.94+ ACRE SITE.
3. GOPHER TORTOISES WITHIN 25' OF AREAS TO BE DISTURBED ARE TO BE RELOCATED AND "AFTER ACTION REPORT" FILED WITH THE COUNTY PRIOR TO ANY CONSTRUCTION ACTIVITIES.

N.A.V.D. 1988 DATUM

ELEVATIONS BASED ON N.G.S. T.B.M. HERNPORT, ELEV.=67.42.
A FLANGE ENCASED 5/8" STEEL ROD LOCATED 140' SOUTH OF TAXIWAY-A, AND 240' WEST OF TAXIWAY A-5.

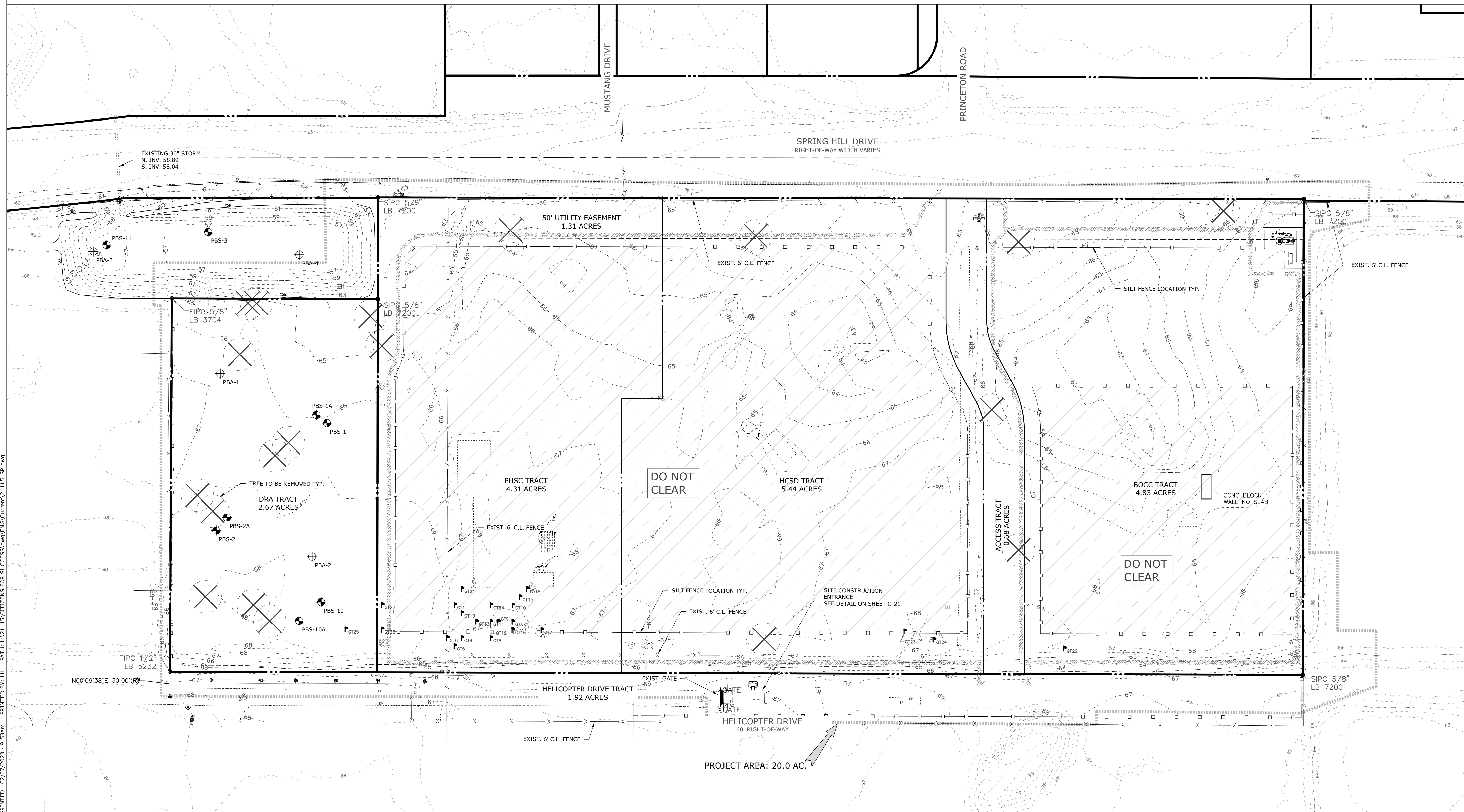
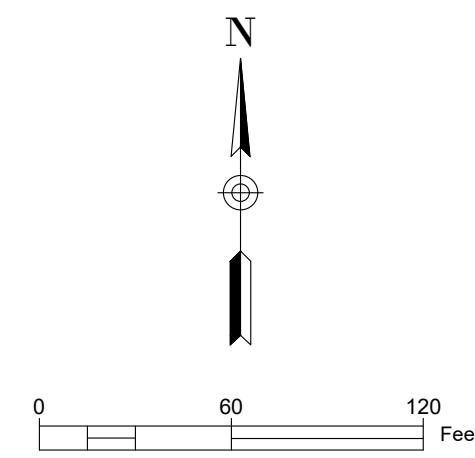

EXISTING CONDITIONS PLAN
DR DENNIS WILFONG CENTER
FOR SUCCESS

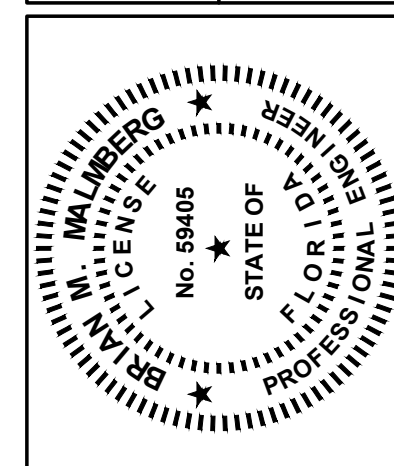

Coastal
Engineering
Surveying
Environmental
Transportation
Construction Management
engineering associates, inc. - Florida 34801
966 Candlelight Boulevard - Brooksville - Fax (352) 799-8359
EB-000142

REUSE OF DOCUMENT
THIS DOCUMENT, COMPRISING OF THE INCORPORATED IDEAS AND PROFESSIONAL SERVICE IS THE PROPERTY OF COASTAL ENGINEERING ASSOCIATES, INC. IT IS NOT TO BE USED IN WHOLE OR IN PART FOR ANY OTHER PURPOSE WITHOUT THE WRITTEN AUTHORIZATION OF COASTAL ENGINEERING ASSOCIATES, INC. DRAWING INVALID UNLESS SIGNED, DATED & SEALED BY REGISTERED PROFESSIONAL ENGINEER.

DATE	REV. BY/REV. NO.	REVISION
09/13/22	LEE	1
10-13-22	LEE	2
1-24-23	LEE	3

SHEET
C-03
JOB No. 21115

PRINTED: 02/07/2023 - 9:53am PRINTED BY: LH PATH: L:\21115\CITIZENS FOR SUCCESS\dwg\Current\21115_SP.dwg

SITE DATA

OWNER/PERMITTEE: HERNANDO COUNTY DEPARTMENT PUBLIC WORKS
 ATTN: ERIK VAN DE BOOGAARD
 1525 EAST JEFFERSON STREET
 BROOKSVILLE, FL 34601
 (352) 754-4096 X17037
 EMAIL: EVanDeBoogaard@co.hernando.fl.us

ENGINEER/ SURVEYOR: COASTAL ENGINEERING ASSOC., INC.
 ATTN: BRIAN M. MALMBERG, PE
 966 CANDLELIGHT BLVD.
 BROOKSVILLE, FLA. 34601
 PH: (352) 796-9423
 EMAIL: bmalMBERG@coastal-engineering.com

PARCEL KEY: 1711188, 1354493

PARCEL ADDRESS: NOT ASSIGNED

FEMA FLOOD ZONE: THE PROPERTY DESCRIBED HEREON APPEARS TO BE IN FLOOD ZONE "X" (AREA DETERMINED TO FALL OUTSIDE OF THE 0.2% CHANCE ANNUAL FLOODPLAIN); FLOOD ZONE "AE" (BASE FLOOD ELEVATION 66.10'); FLOOD ZONE "AE" (BASE FLOOD ZONE 67.20'); FLOOD ZONE "AE" (BASE FLOOD ELEVATION 66.40') AND FLOOD ZONE "A" (NO BASE FLOOD ELEVATION DETERMINED) AS SCALED FROM THE FLOOD INSURANCE RATE MAP COMMUNITY NUMBER 120110, MAP NUMBER 12053C, PANEL NUMBER 0327-D, EFFECTIVE DATE 02/02/2012.

PROPERTY AREA: ± 16.74 ACRES

NO SURFACE WATERS ONSITE.

UTILITIES

A: WATER AND SEWER; HERNANDO COUNTY UTILITIES
 B: ELECTRIC; DUKE ENERGY
 C: TELEPHONE; BELLSOUTH

FIRE PROTECTION: HERNANDO COUNTY FIRE RESCUE

SOIL CLASSIFICATION: KENDRICK FINE SAND, AND MASARYK VERY FINE SAND

BUILDING SETBACKS: PROJECT SITE IS ZONED PSFOD
 FRONT: 75' SPRING HILL DRIVE
 SIDES: 20'
 REAR: 35'

GENERAL PERMITTING REQUIREMENTS:
 ENVIRONMENTAL RESOURCE - STANDARD GENERAL NPDES - CONSTRUCTION SITE > 1 AC
 HERNANDO COUNTY - BUILDING PERMIT
 BROOKSVILLE - TAMPA BAY REGIONAL AIRPORT RIGHT-OF-WAY UTILIZATION PERMIT

SIGNAGE AND STRIPING LEGEND:

- 1 STOP SIGN "STOP SIGN" R1-1 30"x30"
- 2 END OF ROAD MARKERS* 18"x18" RED OM4-1 OR OM4-3 REFER TO HCFDG DETAIL V-03
- 3 120 LF 6" DBL YELLOW STRIPE
- 4 25 LF 6" DBL YELLOW STRIPE
- 5 24" STOP BAR "WHITE" (THERMO)
- 6 120 LF 6" "WHITE" STRIPE
- 7 TURN ARROWS PER FDOT INDEX 711-001
- 8 LETTERING PER FDOT INDEX 711-001
- 9 5' WIDE PAVED SHOULDER
- 10 6" DBL YELLOW STRIPE

- 11 MONUMENT SIGN LOCATION PROVIDE ELECTRIC POWER SIGN TO BE DESIGNED AND PERMITTED THROUGH HERNANDO COUNTY AS A SEPARATE PROJECT.
- 12 5' CONCRETE SIDEWALK (ADD AS ALTERNATE BID ITEM)
- 13 2' WIDE DETECTABLE WARNING STRIP "RED" PER FDOT INDEX 522-002
- 14 STANDARD CROSSWALK PER FDOT INDEX 711-001 (THERMO)
- 15 10"x10"x4" THICK CONCRETE PAD (ADD ALTERNATE BID ITEM)

SIGNAGE AND STRIPING NOTES:

- ALL STRIPING WITHIN THE COUNTY RIGHT-OF-WAY SHALL BE THERMOPLASTIC.
- STOP BARS TO BE LOCATED 4' BEHIND CROSSWALKS WHERE APPLICABLE. REFER TO HC DETAIL V-01 AND V-07 OF HERNANDO COUNTY FACILITIES DESIGN GUIDELINES.

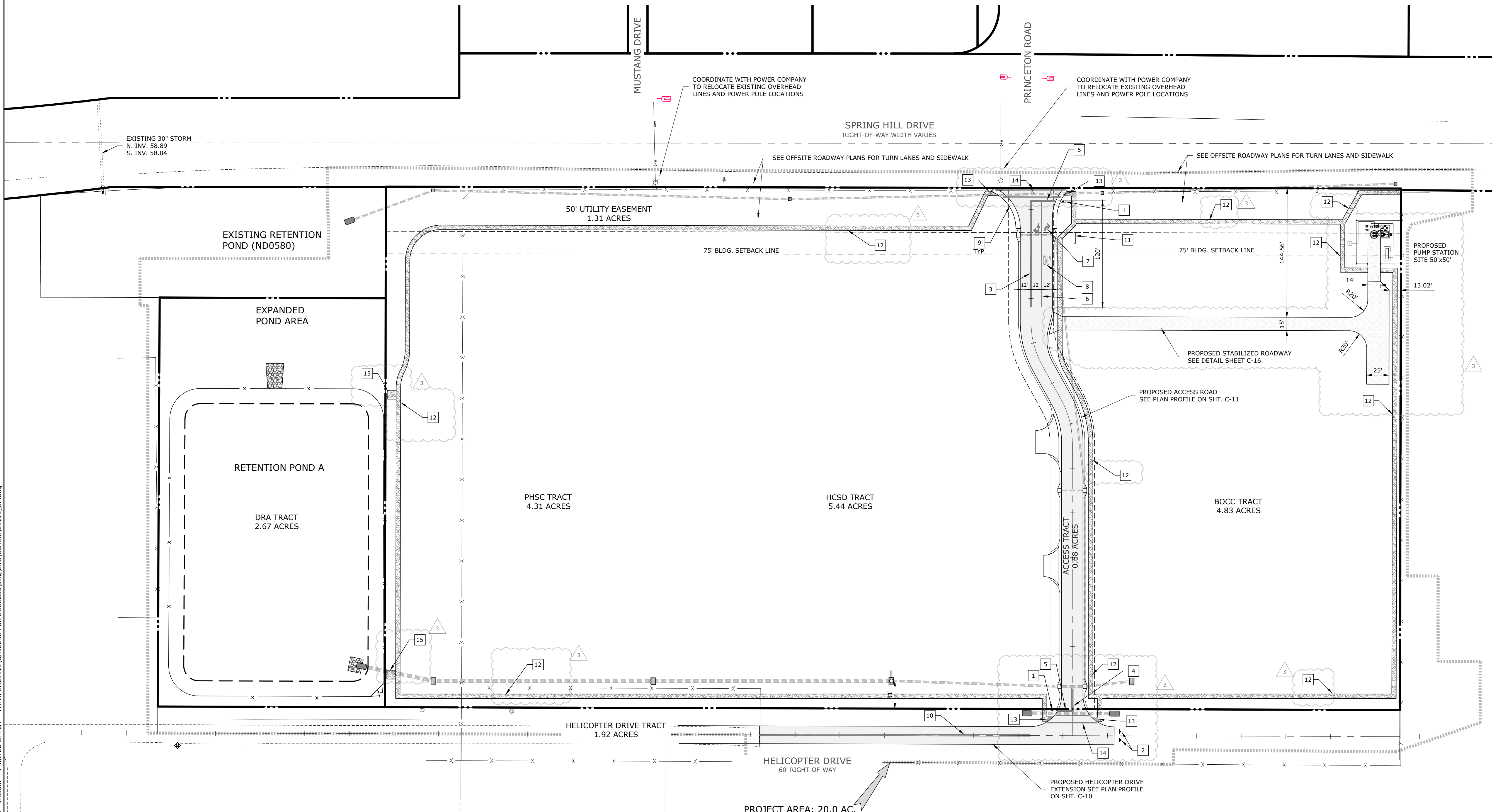
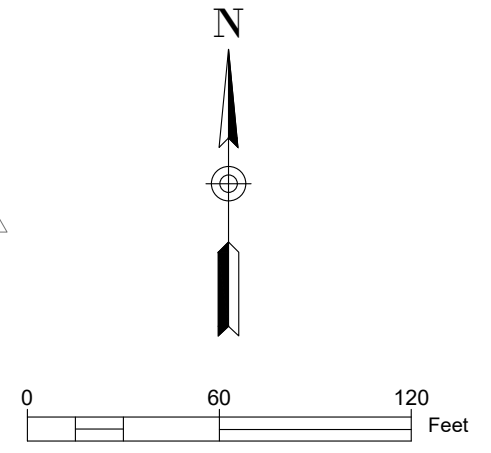

MASTER SITE PLAN

DR DENNIS WILFONG CENTER
FOR SUCCESS

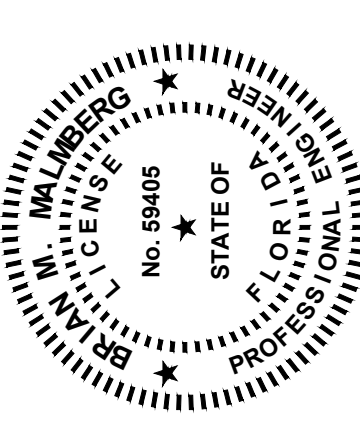

Engineering
 Surveying
 Environmental
 Transportation
 Construction Management

Coastal
 engineering associates, inc.
 966 Candlelight Boulevard - Brooksville - Florida 34601
 (352) 796-9423 - Fax (352) 799-8359
 EB-0000142

REUSE OF DOCUMENT
 THIS DOCUMENT COMPRISED OF THE INCORPORATED IDEAS AND PROFESSIONAL SERVICE IS THE PROPERTY OF COASTAL ENGINEERING ASSOCIATES, INC. IT IS NOT TO BE USED IN WHOLE OR IN PART FOR ANY OTHER PURPOSE WITHOUT THE AUTHORIZATION OF COASTAL ENGINEERING ASSOCIATES, INC. UNLESS SIGNED, DATED & SEALED BY REGISTERED PROFESSIONAL

DATE	REV. BY/REV. NO.	REVISION
09/13/22	LEE	1 BID SET
10-13-22	LEE	2 ADDRESS HOUD COMMENTS ADJUST UTIL/STRIP
1-24-23	LEE	3 ADDRESS HOUD COMMENTS; ADD ALT BID SIDEWALK

WHEN PRINTED TO SCALE, DRAWING SIZE SHALL BE 22" X 34"

SHEET
C-04

PRINTED: 02/07/2023 - 9:53am PRINTED BY: LH PATH: L:\21115\CITIZENS FOR SUCCESS\dwg\ENG\Current\21115_SP.dwg

- NOTES:
1. SILT FENCE SHALL BE AS SHOWN ON SHEET C-03.
 2. SEE DETAILS SHEET C-16 FOR PAVEMENT TYPICAL SECTIONS AND SPECIFICATIONS.
 3. GRASS AREAS SHALL SLOPE PER PLAN AND IN THE DIRECTION OF THE DRAINAGE FLOW ARROWS SHOWN ON THIS SHEET.
 4. SEE SHEET C-11 FOR DIMENSIONS AND RADII.
 5. ONSITE SOIL MATERIAL MEETING THE PROJECT SPECIFICATIONS FOR SUITABLE FILL SHALL BE UTILIZED FOR BACKFILL WHERE APPROPRIATE. IMPORT FILL FROM OFF SITE MAY ALSO BE REQUIRED. MATERIALS UNSUITABLE FOR BACKFILL SHALL BE REMOVED FROM SITE AND PROPERLY DISPOSED OF.
 6. FINISH GRADES SHOWN IN UNPAVED AREAS ARE AFTER COMPACTION AND STABILIZATION.
 7. GRADING/BACKFILL FOR UNPAVED AREAS SHALL BE COMPLETED IN MAXIMUM 12" LIFTS AND COMPACTED IN ACCORDANCE WITH PROJECT SPECIFICATIONS. MINIMUM COMPACTION FOR ANY FILLED AREA SHALL BE 90% OF MAX DENSITY PER ASTM D-1557. DENSITY SAMPLING AND TESTING SHALL BE COMPLETED IN ACCORDANCE WITH PROJECT SPECIFICATIONS.
 8. SITE STABILIZATION SHALL BE PROVIDED FOR ANY/ALL DISTURBED AREAS; SLOPES TO BE SODDED, DRA BOTTOM TO BE SEED/MULCH UNLESS SPECIFIED OTHERWISE SEE SHEET C-06. SOD ROADWAY SHOULDERS.
 9. ALL DISTURBED AREAS WITHIN R/W SHALL BE RESTORED WITH BAHIA SOD PER FDOT SPEC 981 UNLESS SHOWN OTHERWISE.
 10. ALL DRAINAGE STRUCTURES IN PAVED AREAS SHALL INCLUDE H-20 TRAFFIC BEARING STEEL GRATES PER FDOT STANDARD PLANS 425-052.
 11. ALL DRAINAGE STRUCTURES, INCLUDING END TREATMENTS, SHALL BE PER FDOT STANDARDS FOR THE TYPE DESIGNATED (I.E. TYPE FES = FDOT STANDARD PLANS 430-020) UNLESS APPROVED OTHERWISE. YARD INLETS ARE EXCLUDED FROM FDOT STANDARDS.
 12. DRAINAGE PIPE UNDER PAVING SHALL BE REINFORCED CONCRETE PER FDOT SPECIFICATION SECTION 430 UNLESS APPROVED OTHERWISE.
 13. CORRUGATED POLYETHYLENE, CORRUGATED POLYPROPYLENE, OR CORRUGATED POLYVINYLCHLORIDE PIPE, MEETING FDOT SPECIFICATIONS 430 AND 948 SHALL BE ALLOWED FOR AREAS NOT UNDER PAVING.
 14. ALL PIPE LENGTHS ARE APPROXIMATE AND INCLUDE THE END SECTIONS ACTUAL LENGTH MAY VARY SLIGHTLY BASED ON STRUCTURE INSTALLATION

STRUCTURE CHART

- | | | | | | | | | | | | | | |
|---|---|--|---|--|---|--|---|--|---|--|---|--|---|
| ST-1
FDOT TYPE "F" INLET TOP
FDOT INDEX NO: 425-053
TYPE "1" ALT B
STRUCTURE BOTTOM
FDOT INDEX NO: 425-010
GRATE EL. 68.0
E. INV. 60.20
W. INV. 60.20 | ST-2
FDOT TYPE "F" INLET TOP
FDOT INDEX NO: 425-053
TYPE "1" ALT B
STRUCTURE BOTTOM
FDOT INDEX NO: 425-010
GRATE EL. 68.0
E. INV. 61.10
W. INV. 60.60 | ST-3
FDOT TYPE "7" MANHOLE TOP
FDOT INDEX NO: 425-001
TYPE "1" ALT B
STRUCTURE BOTTOM
FDOT INDEX NO: 425-010
RIM EL. 68.65
E. INV. 62.50
W. INV. 61.70 | ST-4
FDOT GUTTER INLET TYPE "V"
FDOT INDEX NO: 425-041
EOP EL. 67.73
E. INV. 63.20
W. INV. 63.15 | ST-5
FDOT GUTTER INLET TYPE "V"
FDOT INDEX NO: 425-041
EOP EL. 67.73
N. INV. 63.40
E. INV. 63.35
W. INV. 63.30 | ST-6
FDOT TYPE "G" INLET
FDOT INDEX NO: 425-053
GRATE EL. 67.35
W. INV. 63.50 | ST-7
FDOT GUTTER INLET TYPE "V"
FDOT INDEX NO: 425-041
EOP EL. 67.46
W. INV. 63.80
N. INV. 63.70
S. INV. 63.70 | ST-8
FDOT GUTTER INLET TYPE "V"
FDOT INDEX NO: 425-041
EOP EL. 67.73
E. INV. 64.10
S. INV. 64.00 | ST-9
FDOT GUTTER INLET TYPE "V"
FDOT INDEX NO: 425-041
EOP EL. 67.46
E. INV. 64.00 | ST-10
FDOT GUTTER INLET TYPE "V"
FDOT INDEX NO: 425-041
EOP EL. 67.46
E. INV. 64.00 | ST-11
STA. 22+72.79
FDOT INLET TYPE "C"
FDOT INDEX NO: 425-041
GRATE EL. 66.3
W. INV. 62.22 | ST-12
STA. 19+42.73
FDOT INLET TYPE "C"
FDOT INDEX NO: 425-041
GRATE EL. 64.0
E. INV. 60.9
S. INV. 60.8 | ST-13
STA. 15+92.45
FDOT INLET TYPE "C"
FDOT INDEX NO: 425-041
GRATE EL. 63.18
E. INV. 59.20
W. INV. 59.10 | ST-14
STA. 11+92.29
FDOT INLET TYPE "C"
FDOT INDEX NO: 425-041
GRATE EL. 62.5
E. INV. 57.5
W. INV. 57.4 |
|---|---|--|---|--|---|--|---|--|---|--|---|--|---|

FENCE NOTES:

1. IF MODIFICATIONS TO THE EXISTING FENCE ARE REQUIRED, THE CONTRACTOR WILL MAINTAIN AIRPORT SECURITY AT ALL TIMES DURING CONSTRUCTION ACTIVITIES.

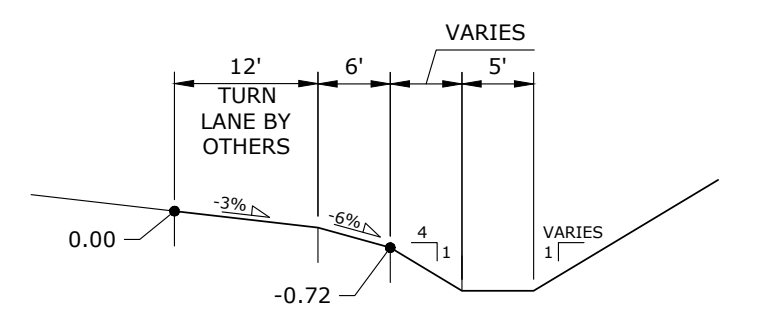

SPRING HILL DRIVE ROADSIDE SWALE DETAIL
NOT TO SCALE
REFER TO OFFSITE ROAD WIDENING PLANS BY OTHERS

LEGEND

- 67 — PROPOSED CONTOUR
- 67 - - - EXISTING CONTOUR
- 25.10 — PROPOSED SPOT GRADE
- MEG — PROPOSED GRADE IS TO MATCH EXISTING
- — PROPOSED PAVEMENT

1. NORTHING & EASTING REPRESENTS CENTER OF STRUCTURE OR INVERT OF MES.
2. TOP ELEVATIONS FOR CURB INLETS = TOP OF BACK OF CURB AT STRUCTURE LOCATION, FOR MANHOLES AND DROP INLETS = TOP OF RIM OR GRATE

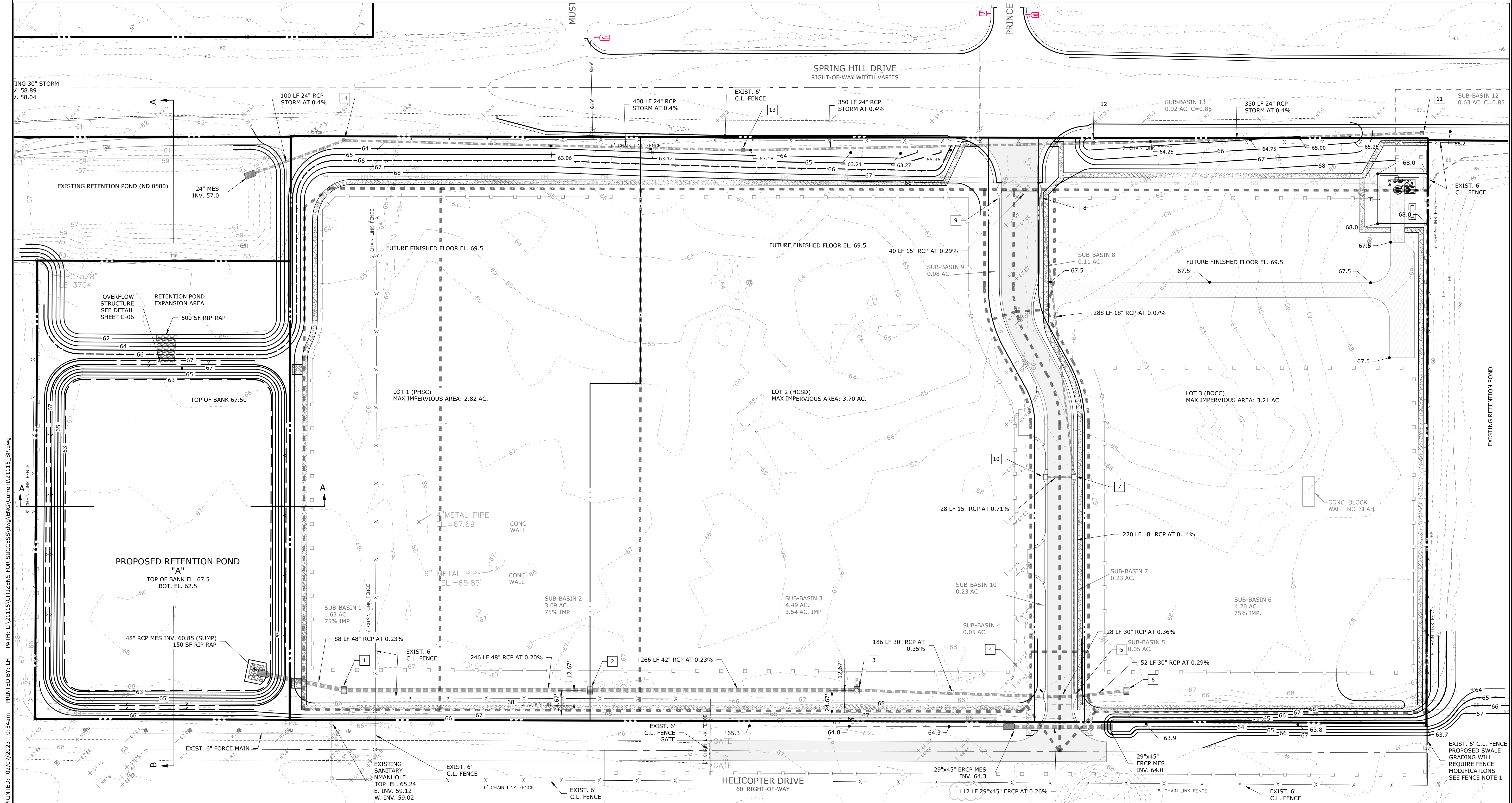

GRADING, DRAINAGE AND PAVING PLAN

DR DENNIS WILFONG CENTER FOR SUCCESS

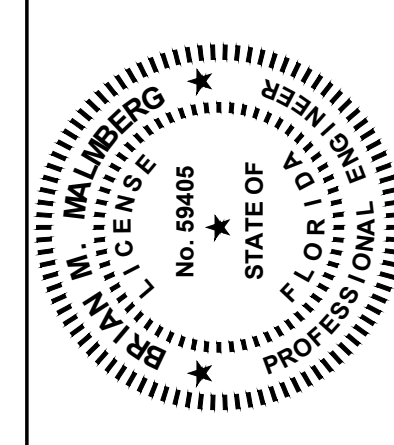

Engineering
Surveying
Environmental
Transportation
Construction Management

Coastal
engineering associates, inc.

966 Candlelight Boulevard - Brooksville - Florida 34601
(352) 796-9423 - Fax (352) 799-8359
EB-0000142

REUSE OF DOCUMENT
THIS DOCUMENT, COMPRISING OF THE INCORPORATED IDEAS AND PROFESSIONAL SERVICE IS THE PROPERTY OF COASTAL ENGINEERING ASSOCIATES, INC. IT IS NOT TO BE USED IN WHOLE OR IN PART FOR ANY OTHER PURPOSE WITHOUT THE AUTHORIZATION OF COASTAL ENGINEERING ASSOCIATES, INC. UNLESS STAMPED, DATED & SEALED BY REGISTERED PROFESSIONAL ENGINEER.

DATE	REV. BY/REV. NO.	REVISION
09/13/22	LEE	1
10-13-22	LEE	2
1-24-23	LEE	3

SHEET
C-05

21115

PRINTED: 02/07/2023 - 9:54am PRINTED BY: LH PATH: L:\21115\CITIZENS FOR SUCCESS\dwg\ENG\Current\21115_SP.dwg

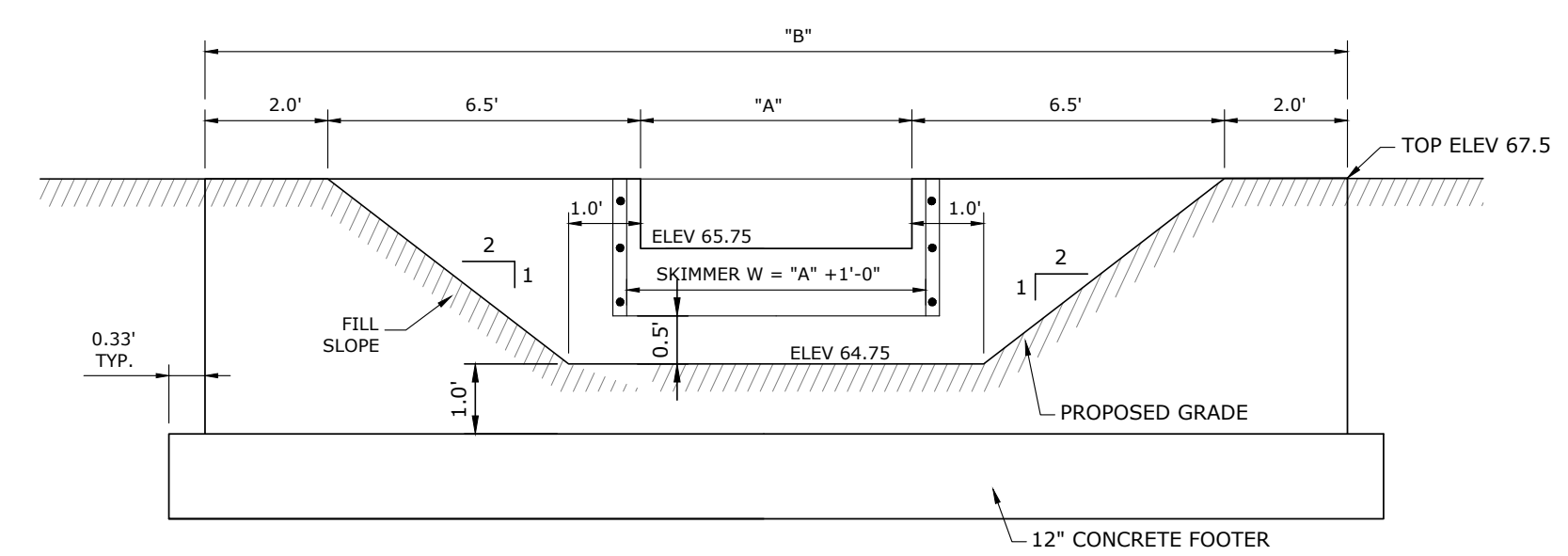
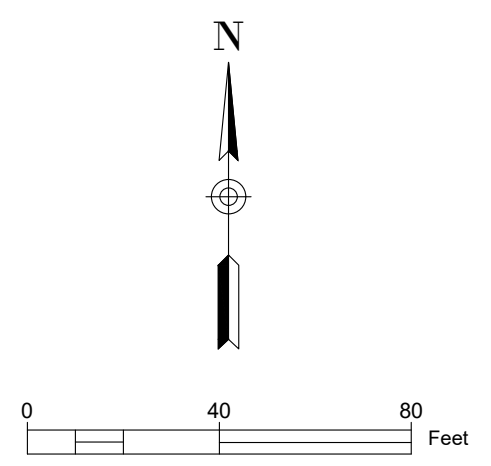
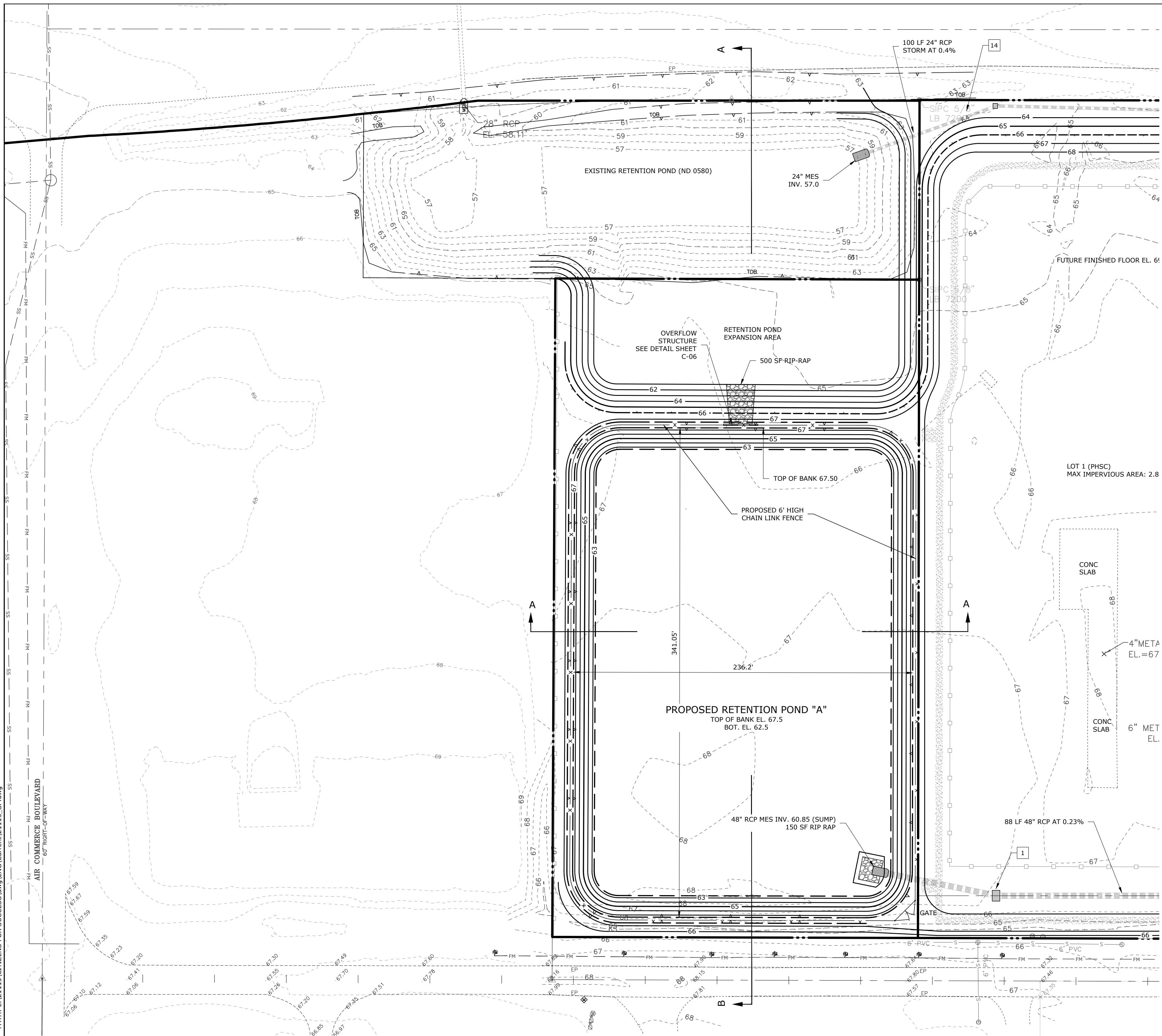

WALL ELEVATION

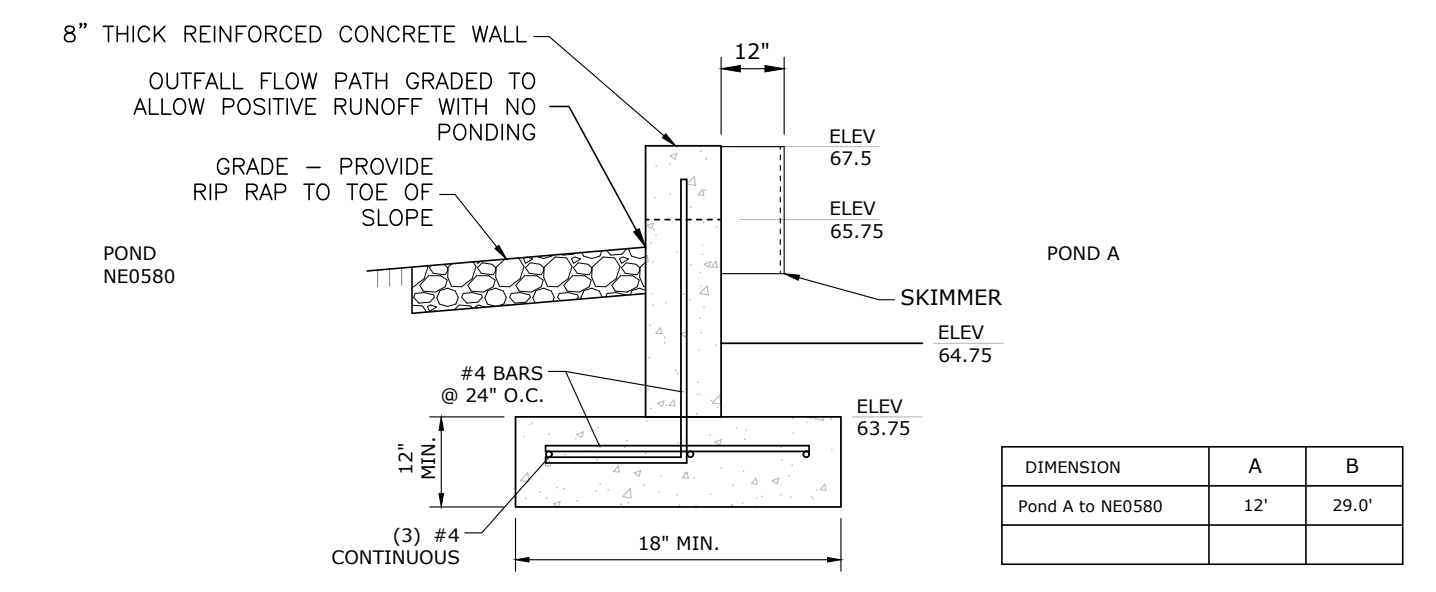

WALL SECTION

OVERFLOW STRUCTURE
NOT TO SCALE

DIMENSION	A	B
Pond A to NE0580	12'	29.0'

POND NE0580 MODIFICATIONS
DR DENNIS WILFONG CENTER FOR SUCCESS

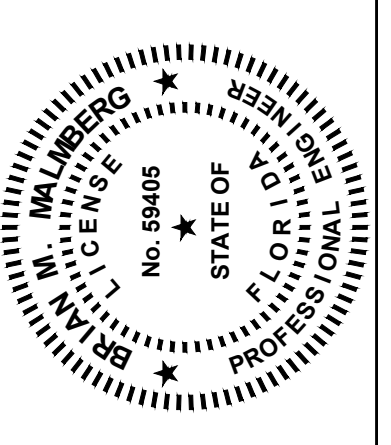

Coastal
engineering associates, inc.
966 Candlelight Boulevard - Brooksville - Florida 34601
(352) 796-9423 - Fax (352) 799-8359
EB-0000142

REUSE OF DOCUMENT
THIS DOCUMENT, COMPRISING ALL THE INCORPORATED IDEAS AND CONCEPTS, IS THE PROPERTY OF COASTAL ENGINEERING ASSOCIATES, INC. IT IS NOT TO BE USED, IN WHOLE OR IN PART, FOR ANY OTHER PURPOSE WITHOUT THE WRITTEN AUTHORIZATION OF COASTAL ENGINEERING ASSOCIATES, INC. DRAWING INVAL. UNLESS SIGNED, DATED & SEALED BY REGISTERED PROFESSIONAL ENGINEER.

DATE	REV. BY/REV. NO.	REVISION
09/13/22	LEE 1	BID SET
10-13-22	LEE 2	ADDRESS HOUD COMMENTS ADJUST UTIL/STURM
1-24-23	LEE 3	ADDRESS HOUD COMMENTS; ADD ALL BID SIDEWALK

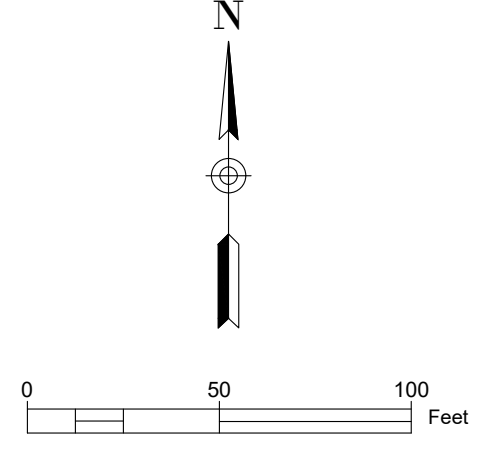
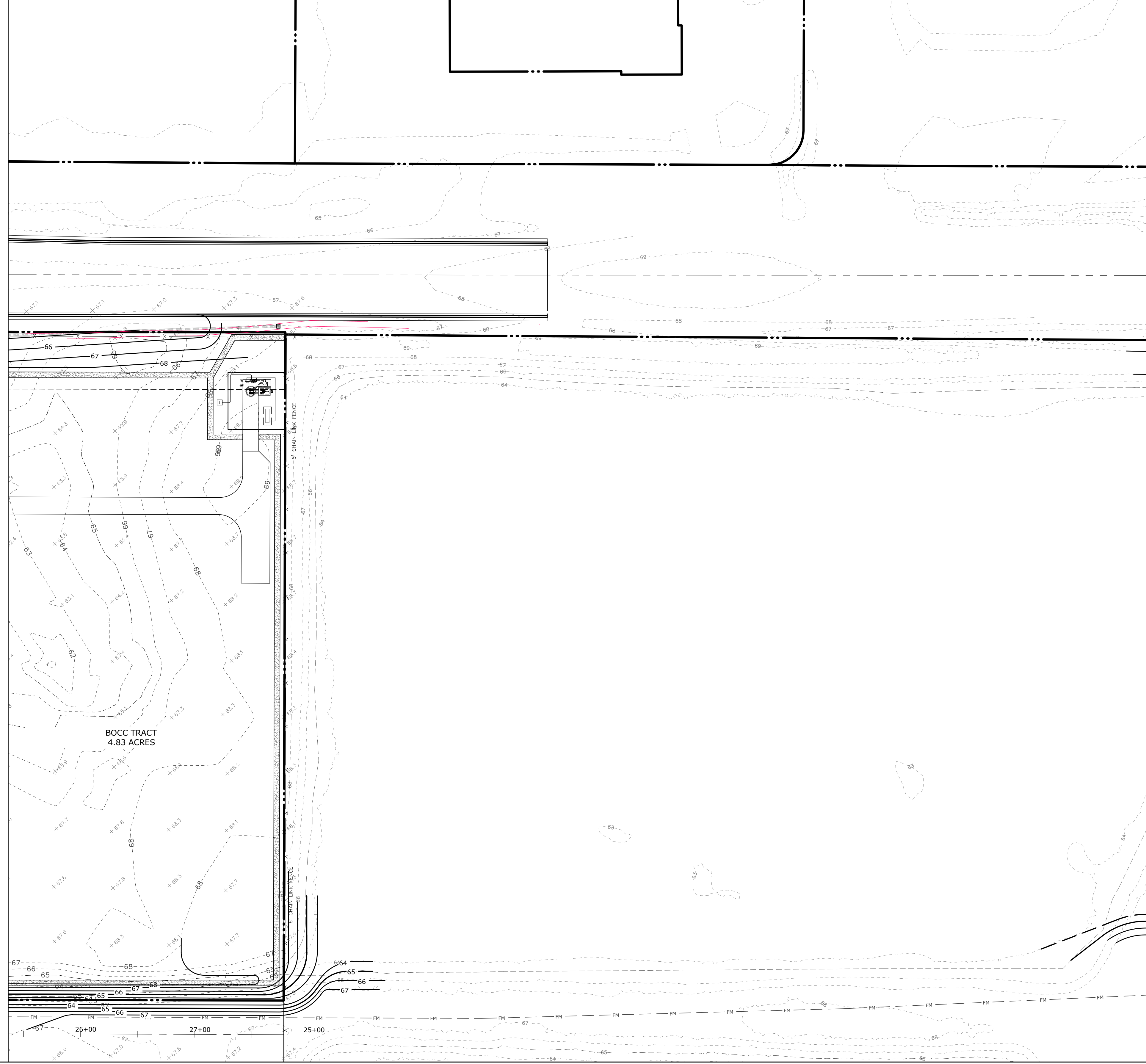

BOCC TRACT
4.83 ACRES

MATCH LINE SEE SHEET C-08

REUSE OF DOCUMENT
THIS DOCUMENT, COMPRISED OF
THE INCORPORATED IDEAS AND
THE PROFESSIONAL SERVICE, IS THE
PROPERTY OF COASTAL
ENGINEERING ASSOCIATES, INC.
IT IS NOT TO BE USED, IN WHOLE OR
IN PART FOR ANY OTHER PURPOSE
WITHOUT THE AUTHORIZATION OF
COASTAL ENGINEERING ASSOCIATES,
INC. UNLESS SO INDICATED.
DRAWING INVALED IF NOT REGISTERED
DATED & SEALED BY REGISTERED
PROFESSIONAL

DATE	REV.	BY/REV.	NO.	REVISION
09/13/22	LEE		1	BID SET
10-13-22	LEE		2	ADDRESS HOUD COMMENTS ADJUST UTIL/STURM
1-24-23	LEE		3	ADDRESS HOUD COMMENTS, ADD ALT BID SIDEWALK

WHEN PRINTED TO SCALE, DRAWING SIZE SHALL BE 22" X 34"

SHEET
C-07
JOB No: 21115

Coastal
engineering associates, inc.
966 Candlelight Boulevard - Brooksville, Florida 34601
(352) 796-9423 - Fax (352) 799-8359
EB-0000142

Engineering
Surveying
Environmental
Transportation
Construction Management

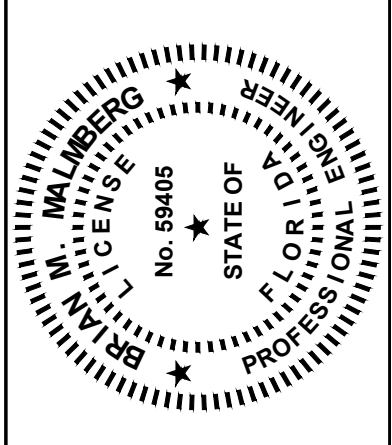

POND ND1000
MODIFICATIONS (1)
DR DENNIS WILFONG CENTER
FOR SUCCESS

MATCH LINE SEE SHEET C-07

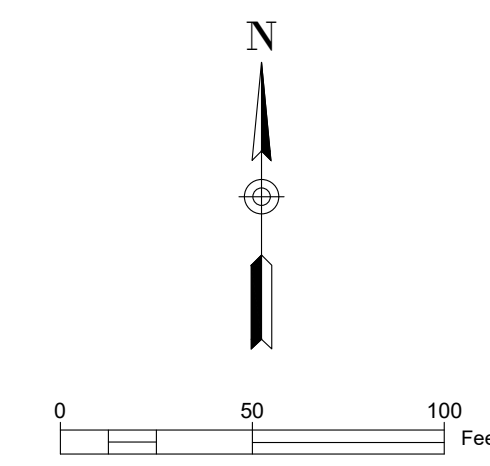
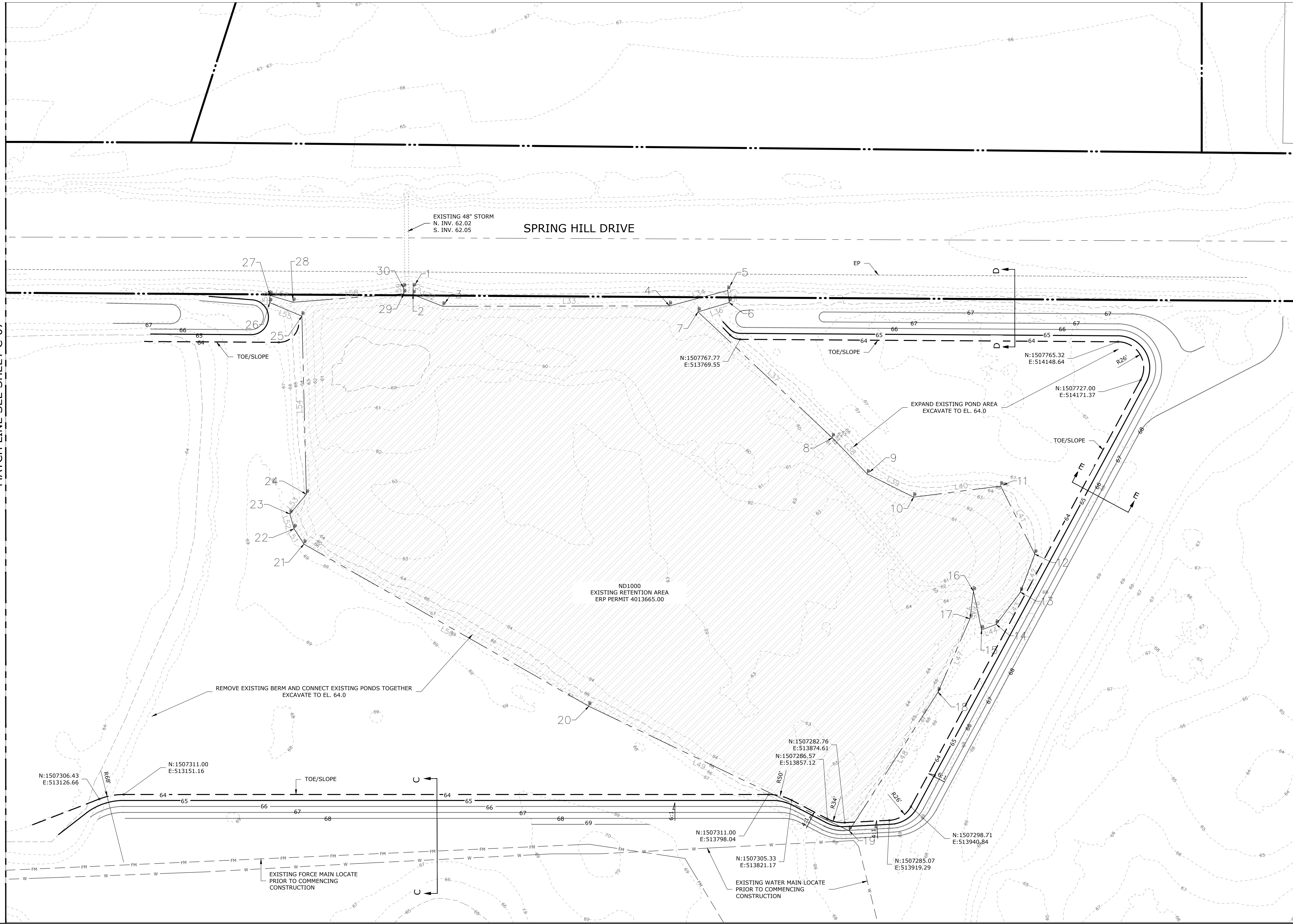

LINE	BEARING	LENGTH
L1	S00°00'00"E	6.68'
L2	S68°26'45"E	32.05'
L3	N89°53'27"E	227.40'
L4	N75°11'57"E	60.43'
L5	S07°06'28"E	12.21'
L6	S73°20'54"W	32.65'
L7	S46°49'19"E	184.65'
L8	S44°00'33"E	50.60'
L9	S63°29'57"E	51.94'
L10	N82°46'02"E	88.02'
L11	S26°38'16"E	76.32'
L12	S20°36'11"W	40.87'
L13	S36°57'29"W	40.48'
L14	S69°47'17"W	15.70'
L15	N11°48'46"W	39.39'
L16	S07°21'33"W	27.75'
L17	S23°30'56"W	80.19'
L18	S32°39'49"W	165.31'
L19	N64°25'36"W	289.47'
L20	N60°20'52"W	328.87'
L21	N32°38'48"W	18.28'
L22	N15°48'43"W	15.42'
L23	N39°43'33"E	25.84'
L24	N01°28'29"W	178.80'
L25	N67°17'58"W	35.05'
L26	N02°07'28"E	7.25'
L27	S73°34'49"E	24.16'
L28	N85°38'37"E	111.47'
L29	N02°51'38"W	5.82'
L30	N88°29'30"E	1482.90'

POND ND1000
MODIFICATIONS (2)
DR DENNIS WILFONG CENTER
FOR SUCCESS

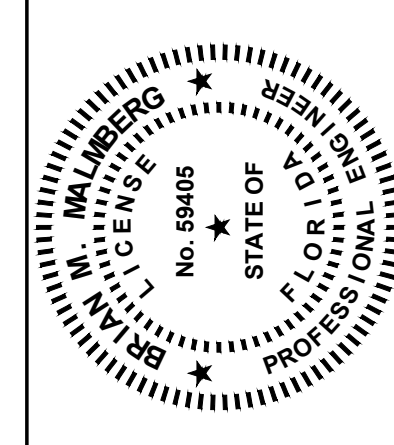

Engineering
Surveying
Environmental
Transportation
Construction Management
Coastal
engineering associates, inc.
966 Candlelight Boulevard - Brooksville - Florida 34601
(352) 796-9423 - Fax (352) 799-8359
EB-000142

REUSE OF DOCUMENT
THIS DOCUMENT, COMPRISED OF THE INCORPORATED IDEAS AND PROFESSIONAL SERVICE IS THE PROPERTY OF COASTAL ENGINEERING ASSOCIATES, INC. IT IS NOT TO BE USED, IN WHOLE OR IN PART FOR ANY OTHER PURPOSE WITHOUT THE AUTHORIZATION OF COASTAL ENGINEERING ASSOCIATES, INC. DRAWING SHALL BE LESS SIGNED, DATED & SEALED BY REGISTERED PROFESSIONAL ENGINEER.

DATE	REV.	BY/REV.	NO.	BID SET	REVISION
09/13/22	LEE	1	1	ADDRESS HOUD COMMENTS	ADJUST UTIL/STURM
10-13-22	LEE	2	2	ADDRESS HOUD COMMENTS	ADD ALT BID
1-24-23	LEE	3	3	ADDRESS HOUD COMMENTS	ADD ALT BID SIDEWALK

WHEN PRINTED TO SCALE, DRAWING SIZE SHALL BE 22" X 34"

SHEET
C-08

JOB No. 21115

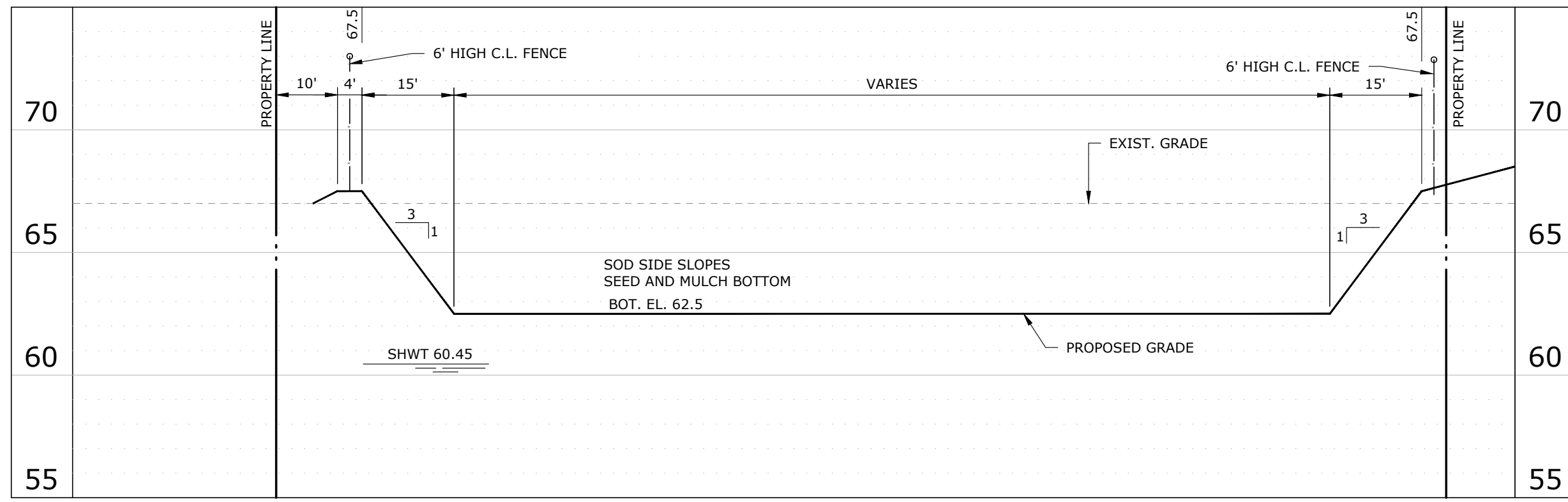

SECTION A-A (POND A)

SCALE: H: 1"=20'
V: 1"=5'

SITE DRA STORMWATER INFORMATION - POST

DESCRIPTION	
POND IDENTIFICATION	POND-A
MIN. BERM/T.O.B. ELEV. (FT.)	67.5
AREA AT TOP OF BANK (AC.)	1.83
BOTTOM ELEVATION (FT.)	62.5
AREA AT BOTTOM (AC.)	1.47
SIDE SLOPE	3:1
10 YR DESIGN HIGH WATER ELEV. (FT.)	65.87
25 YR DESIGN HIGH WATER ELEV. (FT.)	66.08
100 YR DESIGN HIGH WATER ELEV. (FT.)	66.81
AREA AT 100 YR DESIGN HIGH WATER (AC.)	1.78

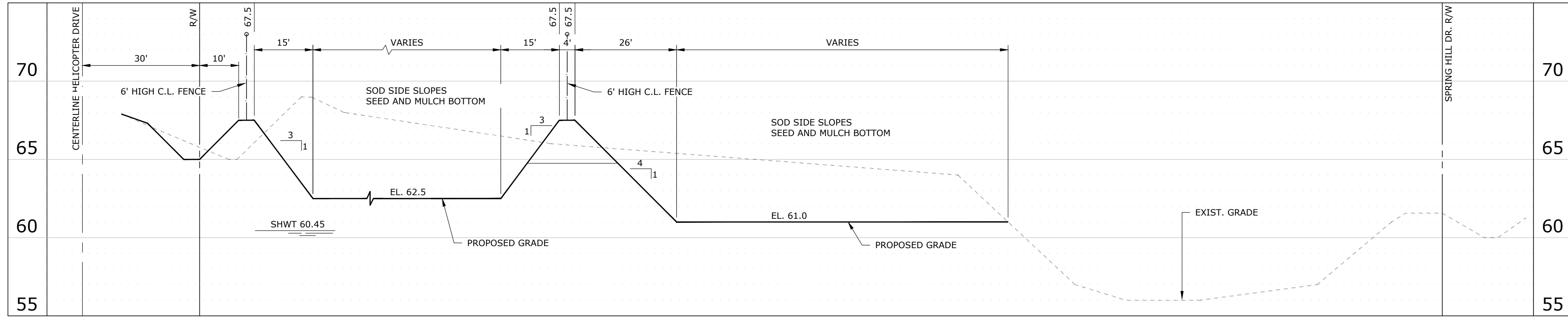
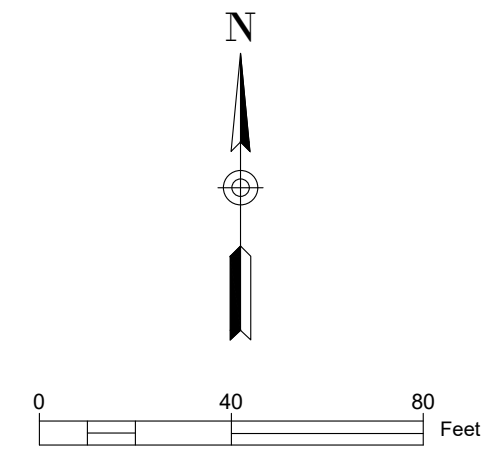

SECTION B-B

SCALE: H: 1"=20'
V: 1"=5'

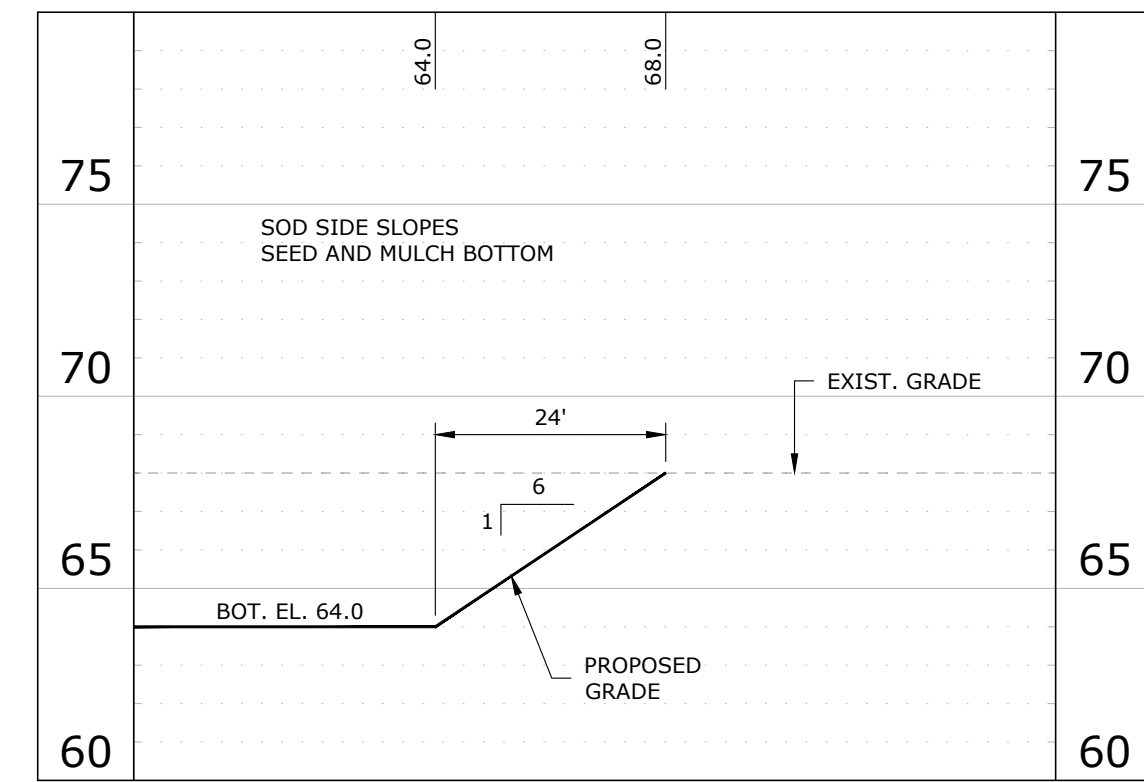

SECTION E-E

SCALE: H: 1"=20'
V: 1"=5'

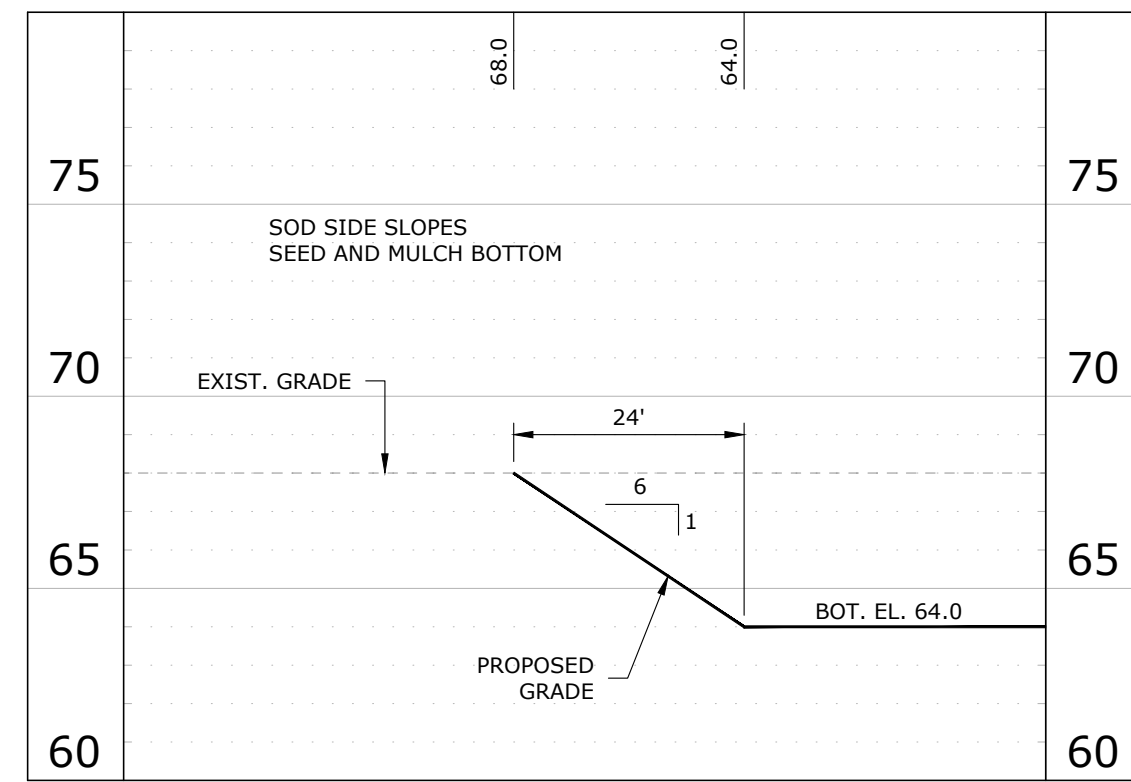

SECTION C-C

SCALE: H: 1"=20'
V: 1"=5'

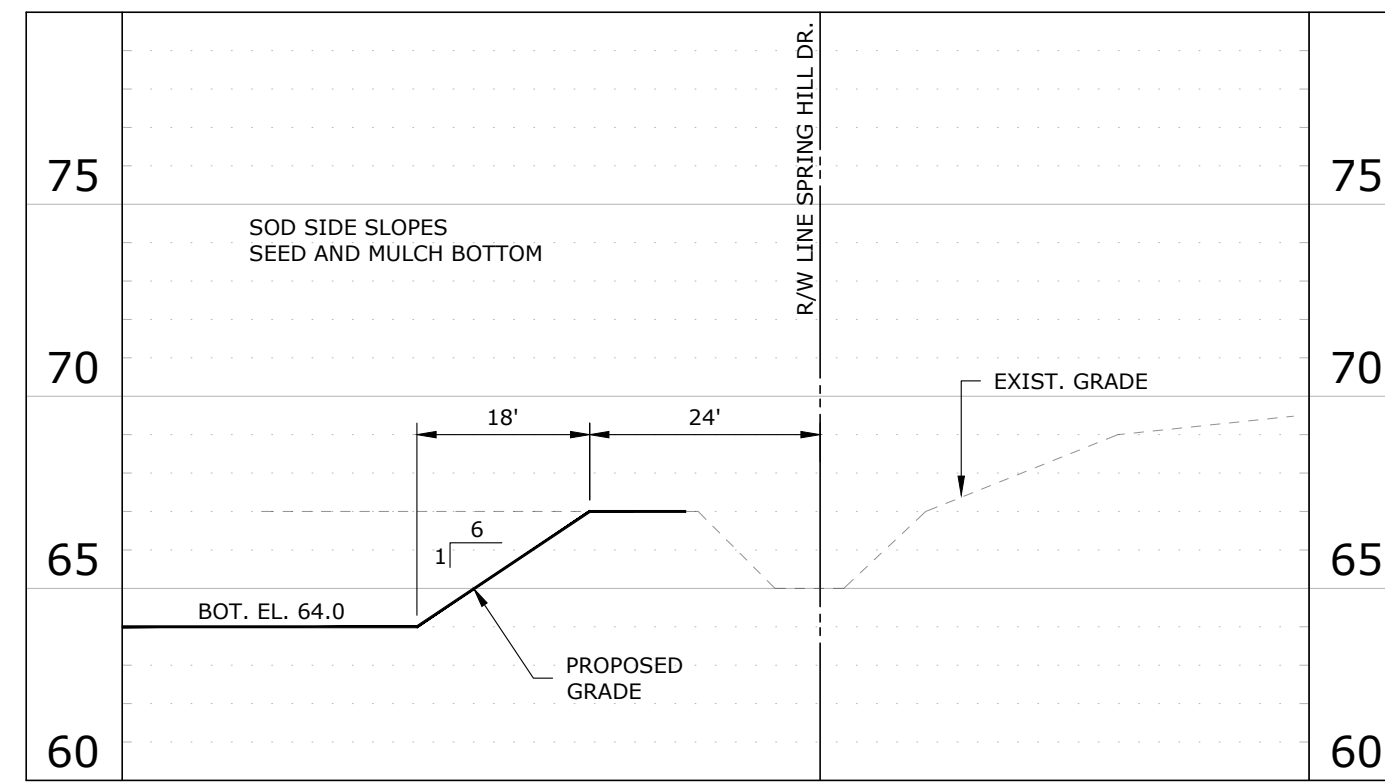

SECTION D-D

SCALE: H: 1"=20'
V: 1"=5'

POND CROSS SECTIONS

DR DENNIS WILFONG CENTER
FOR SUCCESS

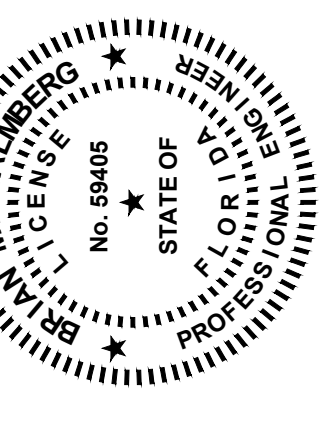

Coastal
engineering associates, inc.
966 Candlelight Boulevard - Brooksville - Florida 34601
(352) 796-9423 - Fax (352) 799-8359
EB-0000142

REUSE OF DOCUMENT
THIS DOCUMENT COMPRISED OF
THE INCORPORATED IDEAS AND
PROFESSIONAL SERVICE IS THE
PROPERTY OF COASTAL
ENGINEERING ASSOCIATES, INC.
IT IS NOT TO BE USED IN WHOLE OR
IN PART FOR ANY OTHER PURPOSE
WITHOUT THE AUTHORIZATION OF
COASTAL ENGINEERING ASSOCIATES,
INC. DRAWING INVAL. UNLESS SIGNED,
DATED & SEALED BY REGISTERED
PROFESSIONAL ENGINEER

DATE	REV.	BY	PREV. NO.	REVISION
09/13/22	LEE	1	BID SET	
10-13-22	LEE	2	ADDRESS HOUD COMMENTS ADJUST UTIL/STURK	
1-24-23	LEE	3	ADDRESS HOUD COMMENTS; ADD ALT BID SIDEWALK	

PRINTED: 02/07/2023 - 9:54am PRINTED BY: LH PATH: L:\21115\CITIZENS FOR SUCCESS\dwg\ENG\Current\21115_SP.dwg

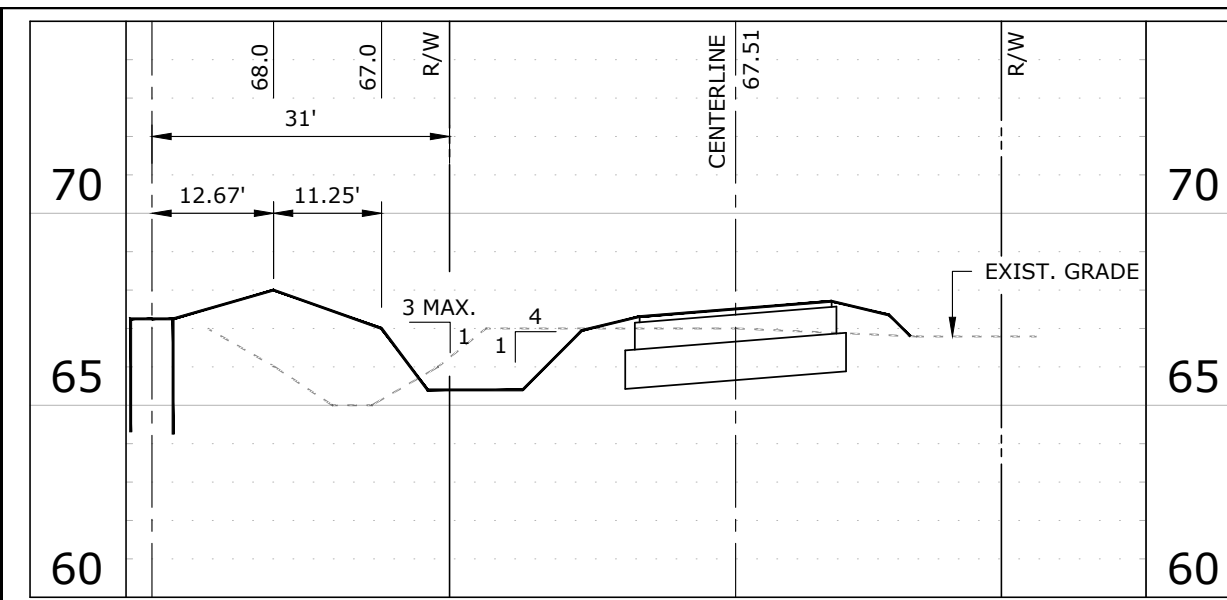

STA. 22+00
SCALE: H: 1"=20'
V: 1"=5'

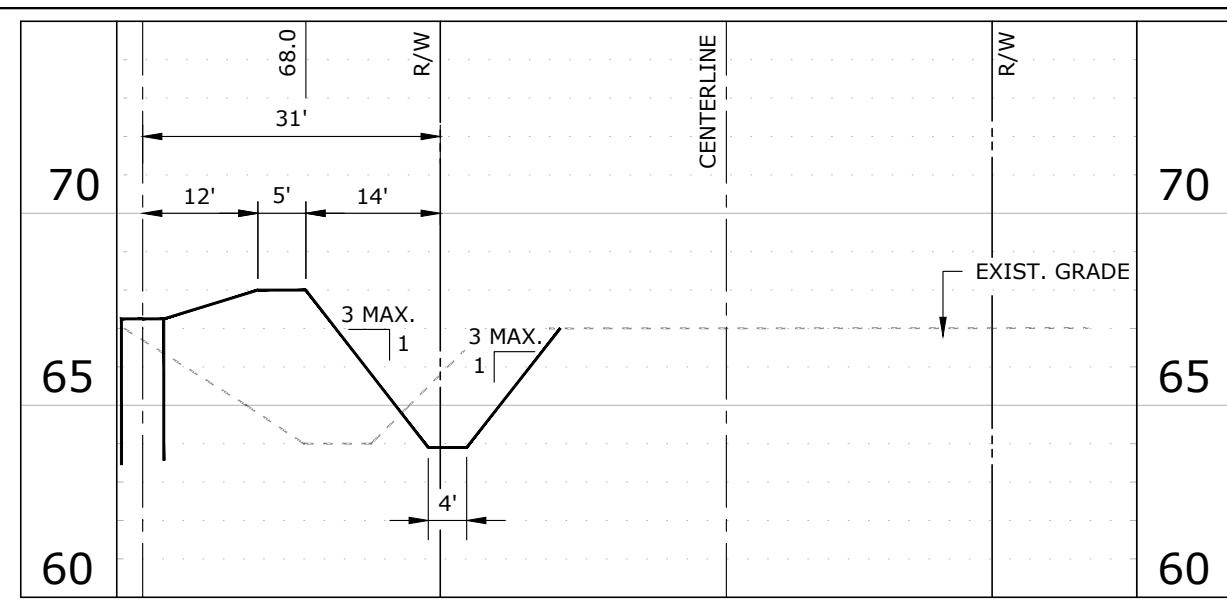

STA. 25+00
SCALE: H: 1"=20'
V: 1"=5'

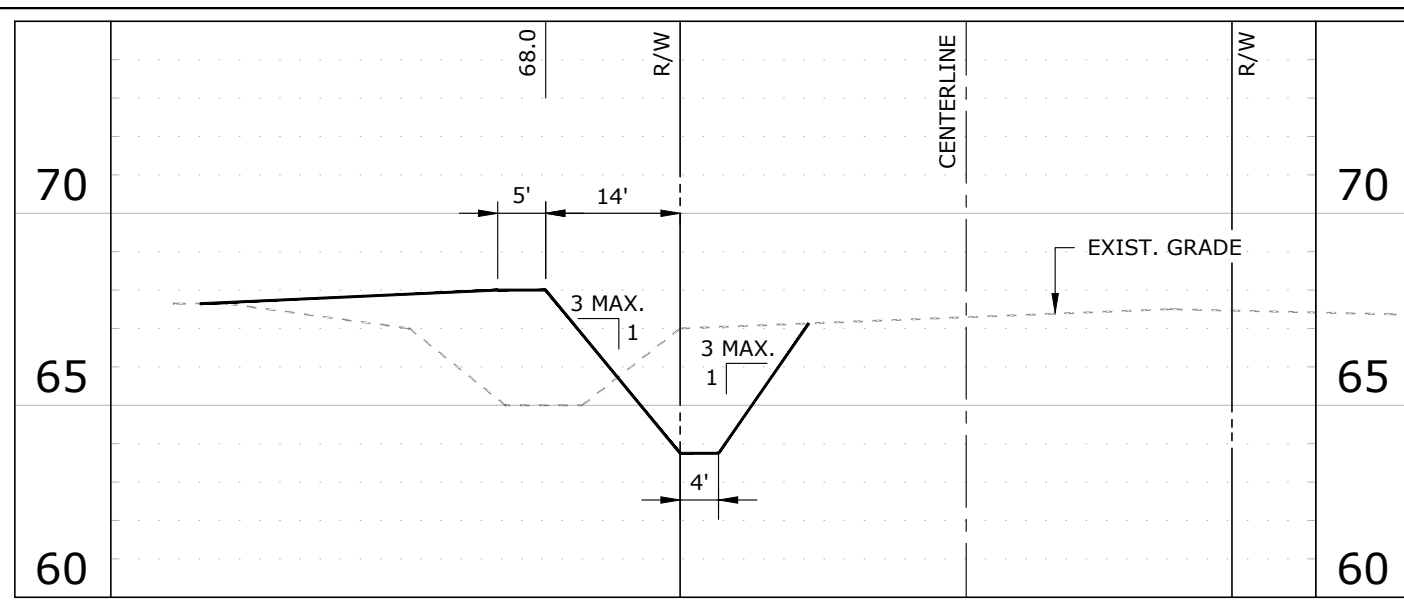

STA. 27+00
SCALE: H: 1"=20'
V: 1"=5'

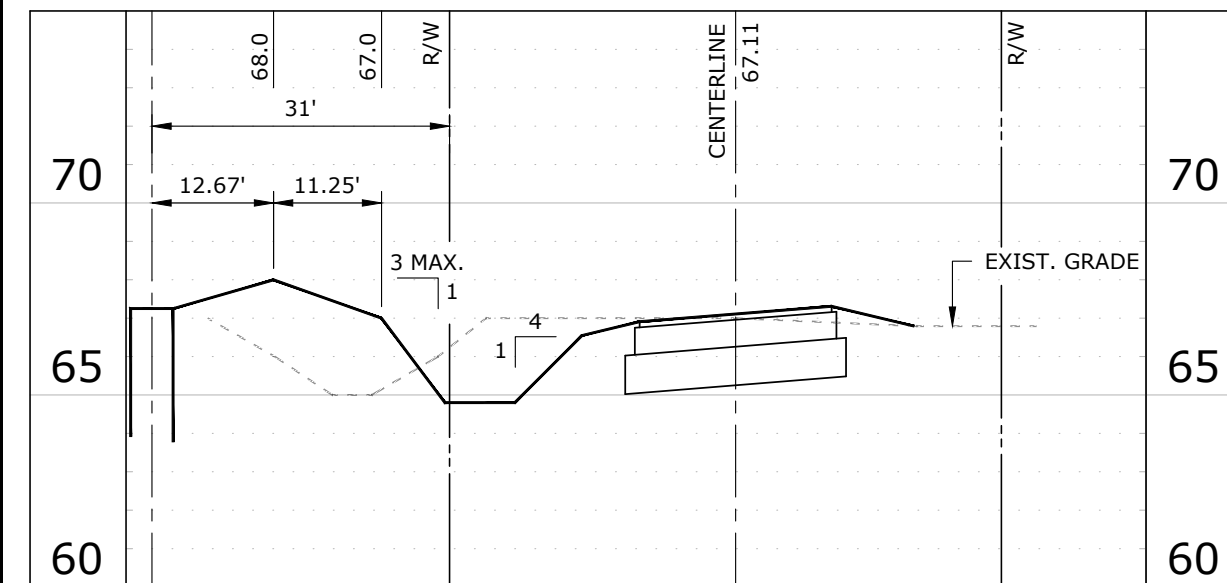

STA. 21+00
SCALE: H: 1"=20'
V: 1"=5'

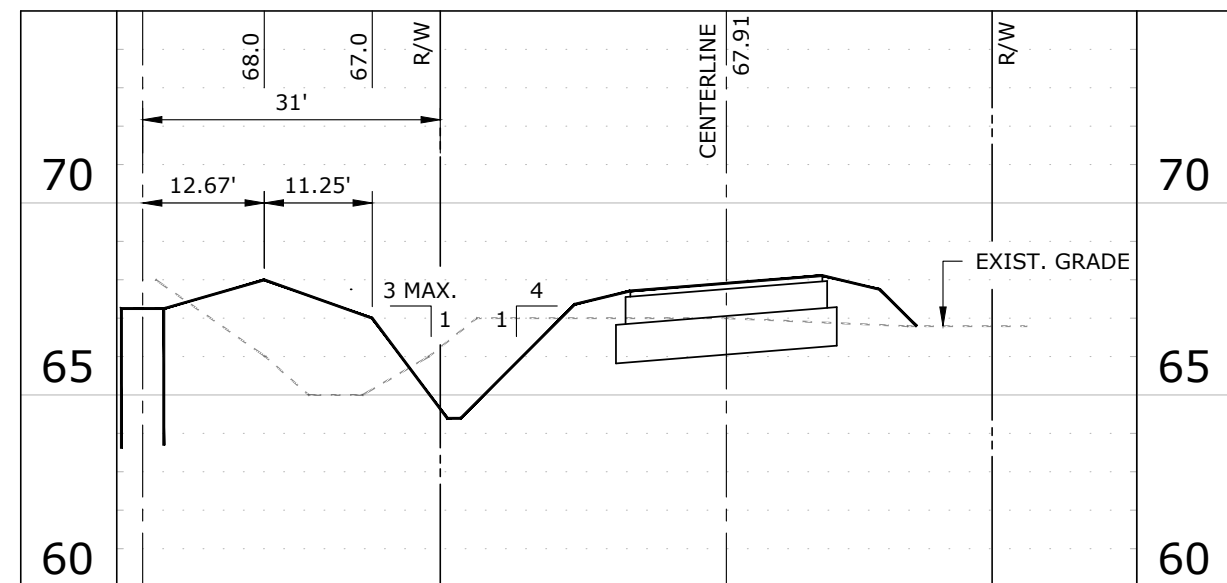

STA. 23+00
SCALE: H: 1"=20'
V: 1"=5'

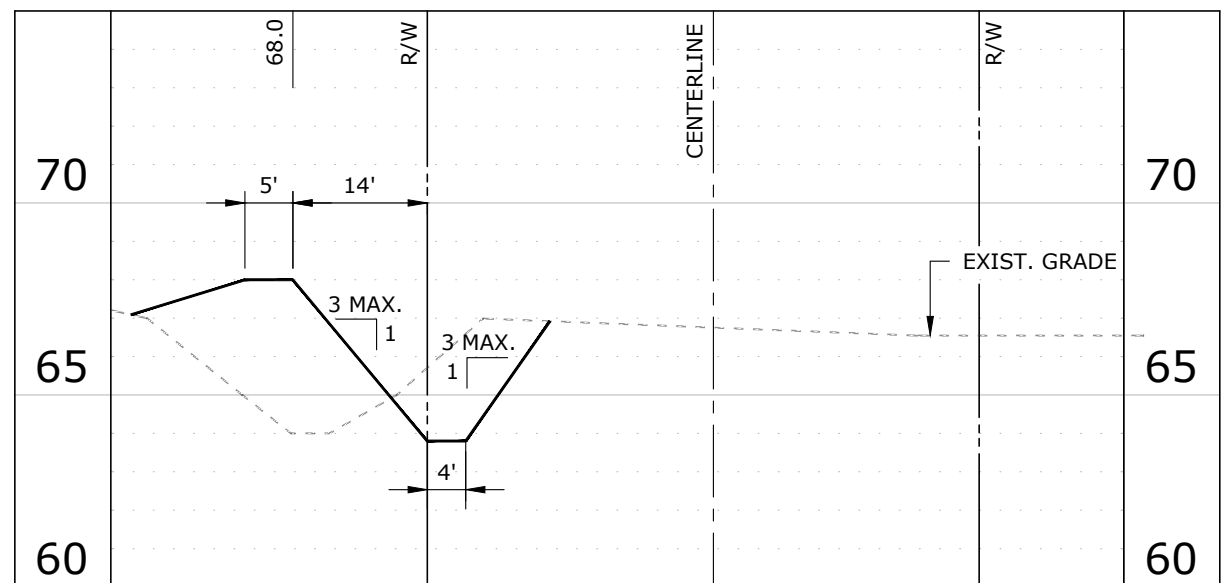

STA. 26+00
SCALE: H: 1"=20'
V: 1"=5'

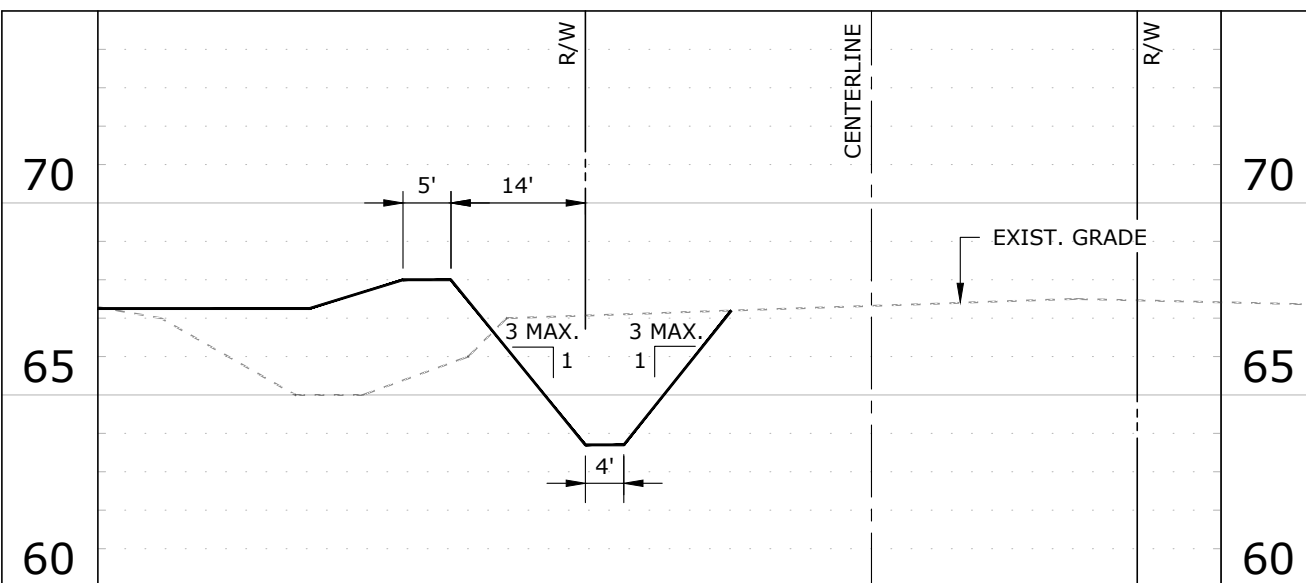

STA. 27+77.7
SCALE: H: 1"=20'
V: 1"=5'

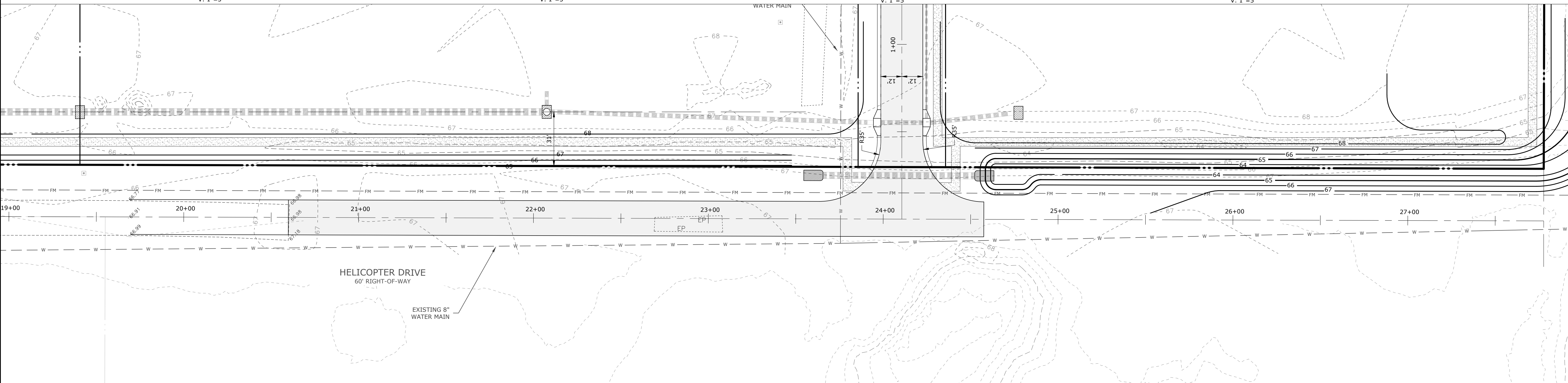
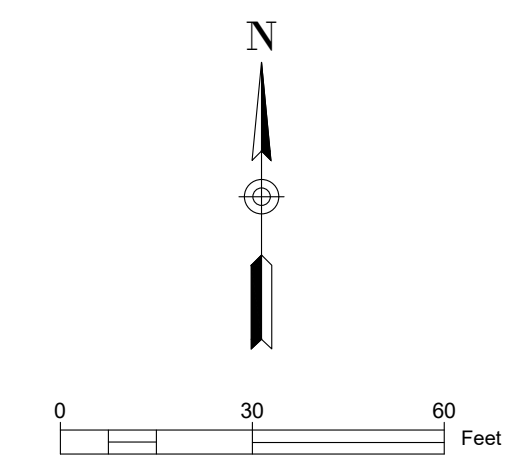

HELICOPTER DRIVE PLAN VIEW
1"=30'

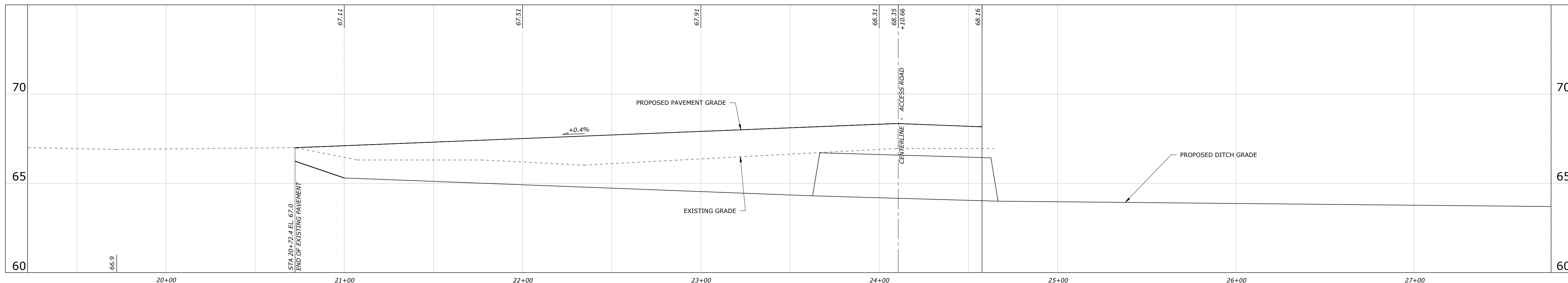

HELICOPTER DRIVE PROFILE
SCALE: H: 1"=30'
V: 1"=3'

HELICOPTER DRIVE PLAN
PROFILE
DR DENNIS WILFONG CENTER
FOR SUCCESS

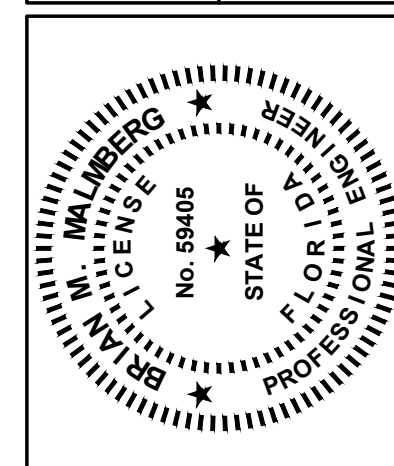

Engineering
Surveying
Environmental
Transportation
Construction Management

Coastal
engineering associates, inc.

966 Candlelight Boulevard - Brooksville, Florida 34601
(352) 796-9423 - Fax (352) 799-8359
EB-0000142

REUSE OF DOCUMENT
THIS DOCUMENT, COMPRISING OF
THE INCORPORATED IDEAS AND
PROFESSIONAL SERVICE IS THE
PROPERTY OF COASTAL
ENGINEERING ASSOCIATES, INC.
IT IS NOT TO BE USED, IN WHOLE OR
IN PART FOR ANY OTHER PURPOSE
WITHOUT THE AUTHORIZATION OF THE
OWNER OR ENGINEERING ASSOCIATES,
COASTAL ENGINEERING ASSOCIATES,
DRAWING INVALED UNLESS SIGNED,
DATED & SEALED BY REGISTERED
PROFESSIONAL ENGINEER

DATE	REV.	BY/REV.	NO.	REVISION
09/13/22	LEE		1	BID SET
10-13-22	LEE		2	ADDRESS HCD COMMENTS ADJUST UTIL/STURK
1-24-23	LEE		3	ADDRESS HCD COMMENTS; ADD ALT BID SIDEWALK

WHEN PRINTED TO SCALE, DRAWING SIZE SHALL BE 22" X 34"

SHEET
C-10
JOB No. 21115

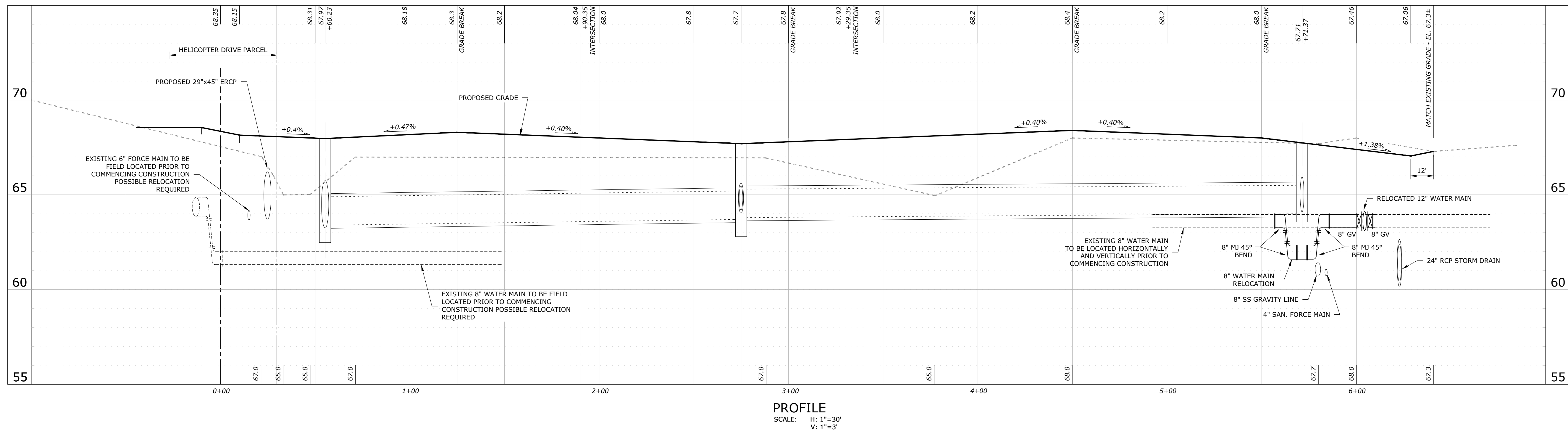

PROFILE
SCALE: H: 1"=30'
V: 1"=3'

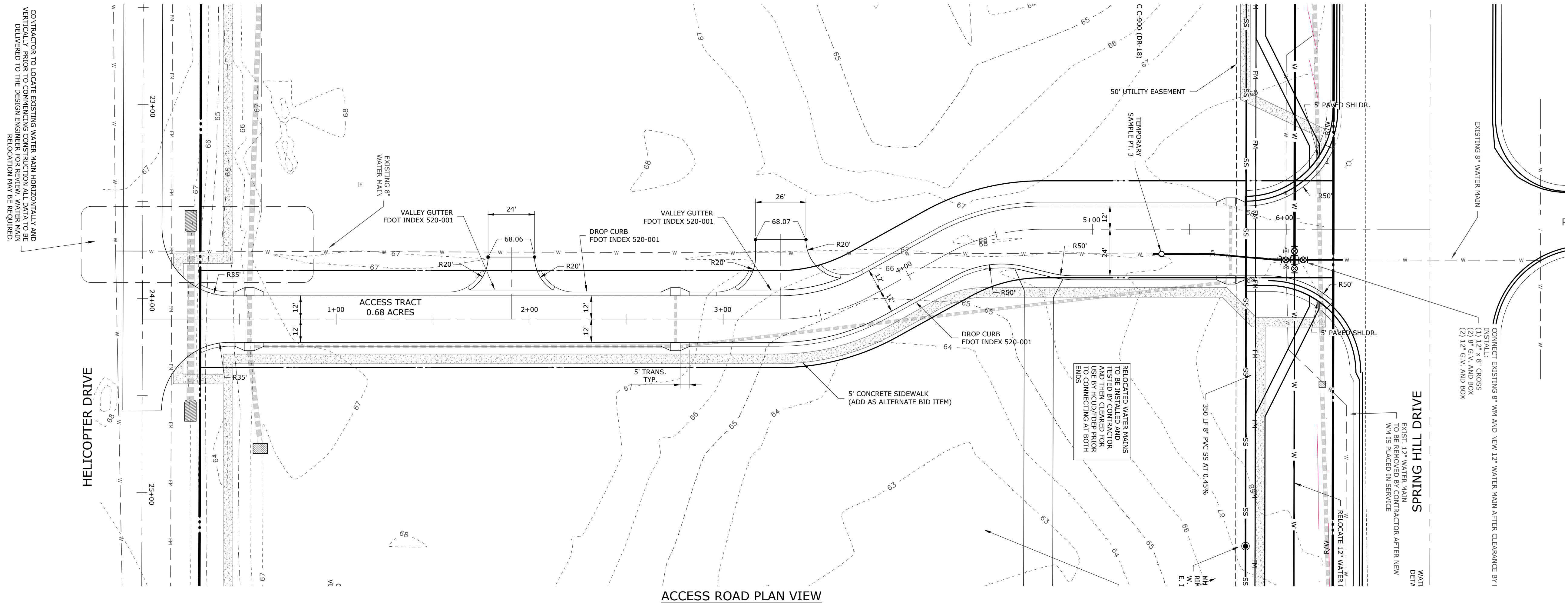

ACCESS ROAD PLAN VIEW
1"=30'

CONTRACTOR TO LOCATE EXISTING WATER MAIN HORIZONTALLY AND VERTICALLY PRIOR TO COMMENCING CONSTRUCTION. ALL DATA TO BE DELIVERED TO THE DESIGN ENGINEER. RELOCATION MAY BE REQUIRED.

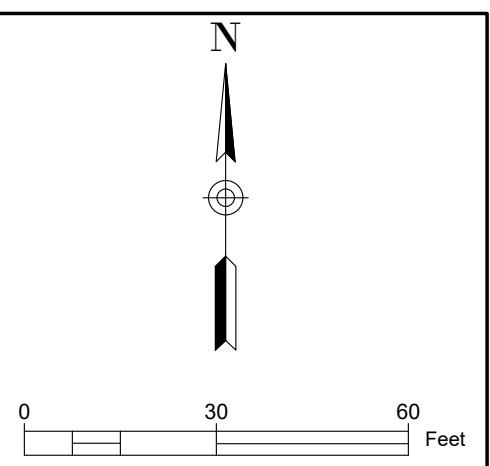

ACCESS ROAD PLAN PROFILE
DR DENNIS WILFONG CENTER FOR SUCCESS

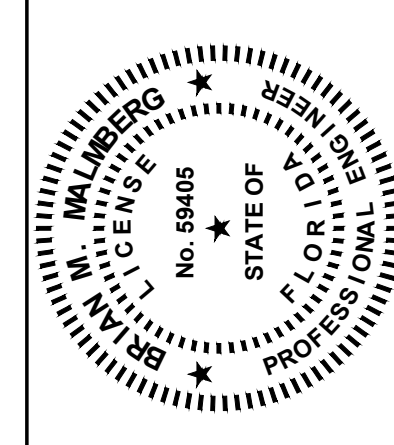

Coastal
Engineering
Surveying
Environmental
Transportation
Construction Management
engineering associates, inc. - Florida 34601
966 Candlelight Boulevard - Brooksville - Florida 34601
(352) 796-9423 - Fax (352) 799-8359
EB-0000142

REUSE OF DOCUMENT
THIS DOCUMENT, COMPRISING OF THE INCORPORATED IDEAS AND PROFESSIONAL SERVICE IS THE PROPERTY OF COASTAL ENGINEERING ASSOCIATES, INC. IT IS NOT TO BE USED IN WHOLE OR IN PART FOR ANY OTHER PURPOSE WITHOUT THE WRITTEN AUTHORIZATION OF COASTAL ENGINEERING ASSOCIATES, INC. UNLESS SIGNED, DATED & SEALED BY REGISTERED PROFESSIONAL ENGINEER.

DATE	REV.	BY/REV.	NO.	REVISION
09/13/22	LEE		1	BID SET
10-13-22	LEE		2	ADDRESS HOOD COMMENTS ADJUST UTIL/STORM ADDRESS HOOD COMMENTS, ADD ALL BID ADDRESS HOOD COMMENTS, ADD ALL BID SIDEWALK
1-24-23	LEE		3	

SHEET
C-11
JOB No: 21115
WHEN PRINTED TO SCALE, DRAWING SIZE SHALL BE 22" X 34"

LEGEND:

- BLOW-OFF ASSEMBLY
- GATE VALVE
- GRAVITY SEWER MAIN
- WATER MAIN
- EXISTING WATER MAIN
- FORCE MAIN
- EXISTING FORCE MAIN
- STORM PIPE
- SILT FENCE

NOTE:
SEE SHEET C-13 FOR NOTES AND LOCATION MAP

LOCATION NOTES:
ALL EXISTING UTILITIES ALONG PROPOSED FORCE MAIN AND WATER LINE RELOCATION ROUTE SHALL BE VERIFIED PRIOR TO COMMENCING CONSTRUCTION

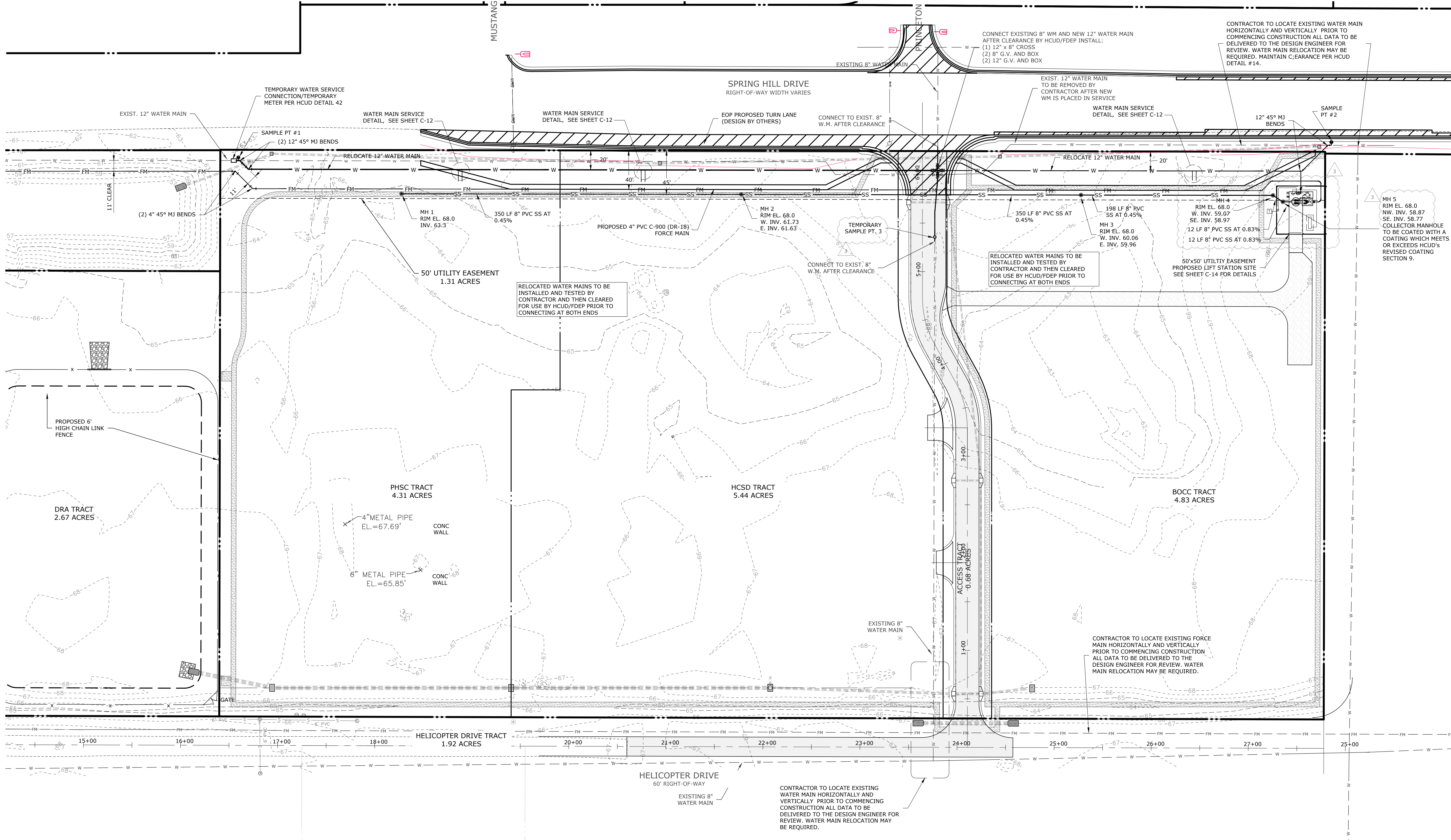
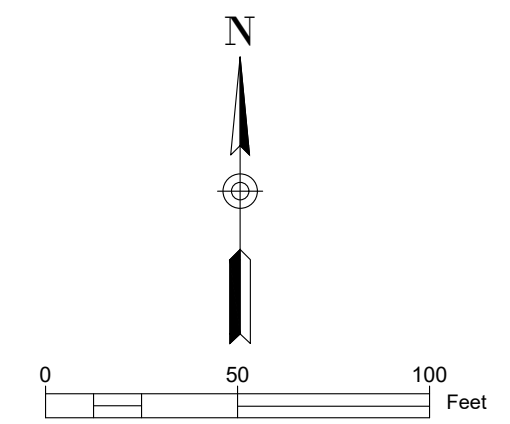
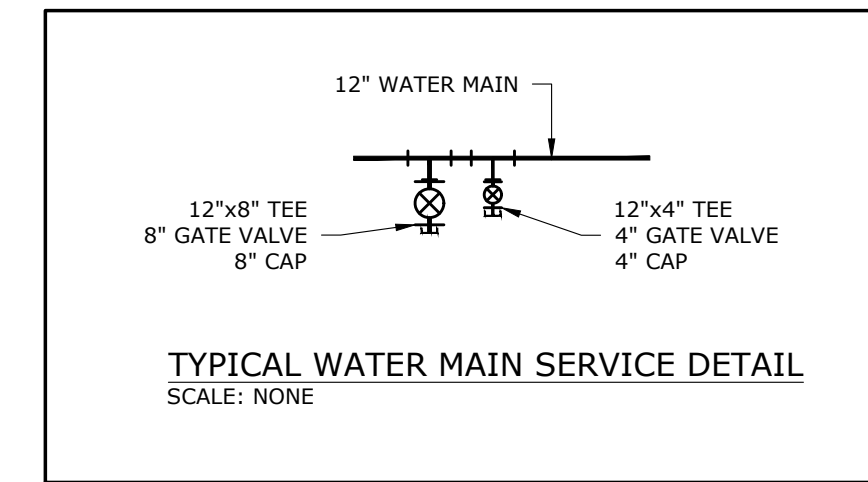

MASTER UTILITY PLAN

DR DENNIS WILFONG CENTER
FOR SUCCESS

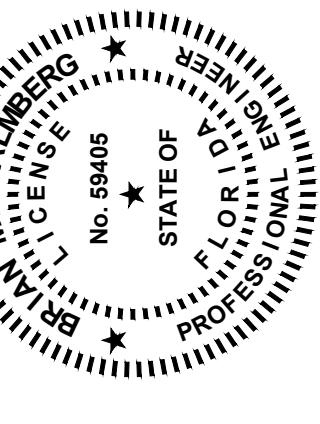

Coastal
engineering associates, inc.
966 Candlelight Boulevard - Brooksville - Florida 34601
(352) 796-9423 - Fax (352) 799-8359
EB-0000142

REUSE OF DOCUMENT
THIS DOCUMENT, COMPRISING OF THE INCORPORATED IDEAS AND THE PROFESSIONAL SERVICE IS THE PROPERTY OF COASTAL ENGINEERING ASSOCIATES, INC. IT IS NOT TO BE USED, IN WHOLE OR IN PART FOR ANY OTHER PURPOSE WITHOUT THE AUTHORIZATION OF COASTAL ENGINEERING ASSOCIATES, INC. DRAWING INVAL. IF NOT LESS SIGNED, DATED & SEALED BY REGISTERED PROFESSIONAL

DATE	REV.	BY/REV.	NO.	BID SET	REVISION
09/13/22	1	LEE	1	ADDRESS HCUD COMMENTS	ADJUST UTIL/STORM
10-13-22	2	LEE	2	ADDRESS HCUD COMMENTS	ADD ALT BID
1-24-23	3	LEE	3	ADDRESS HCUD COMMENTS	ADD ALT BID SIDEWALK

WHEN PRINTED TO SCALE, DRAWING SIZE SHALL BE 22" X 34"

SHEET
C-12

JOB No: 21115

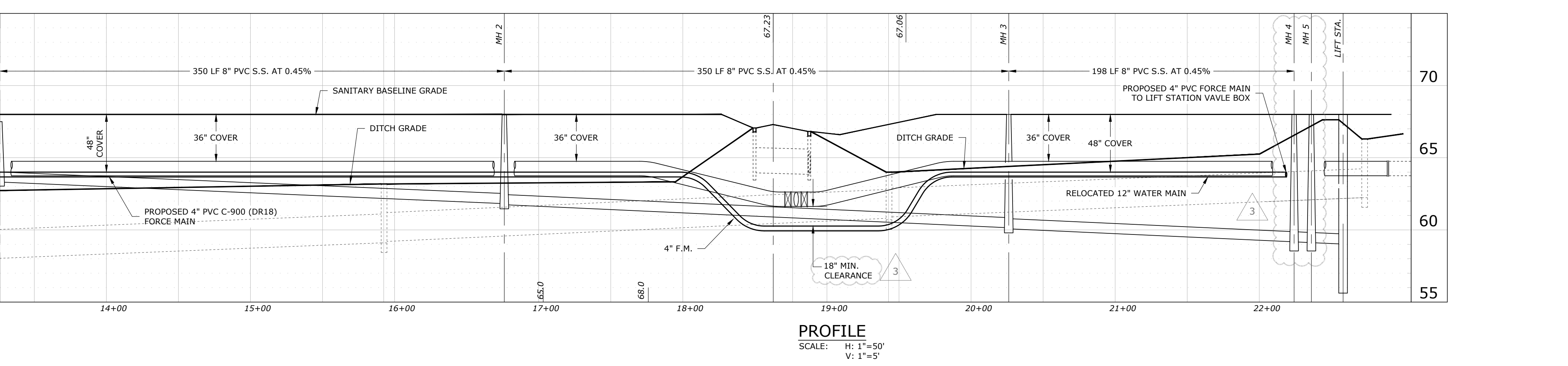
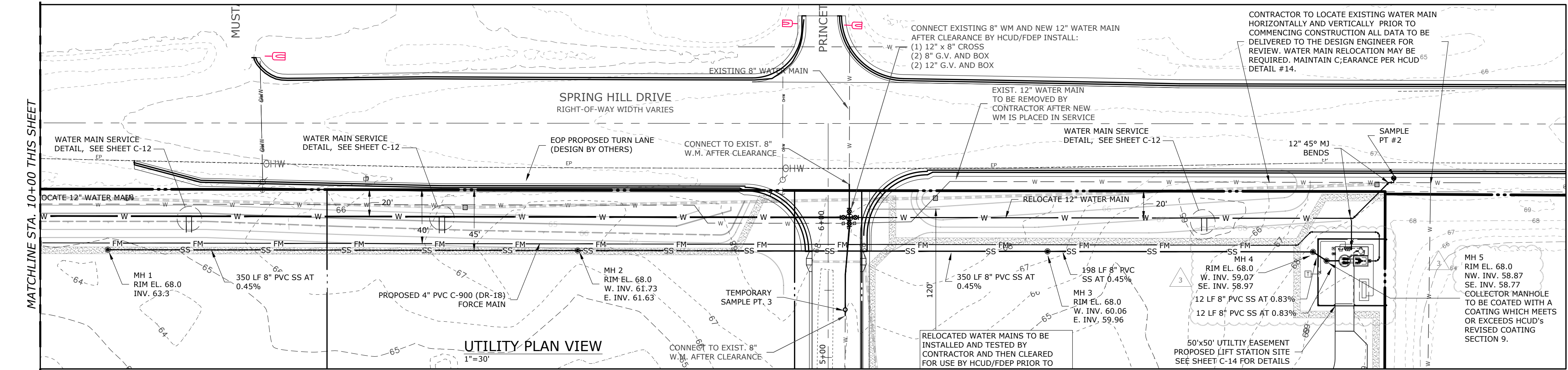
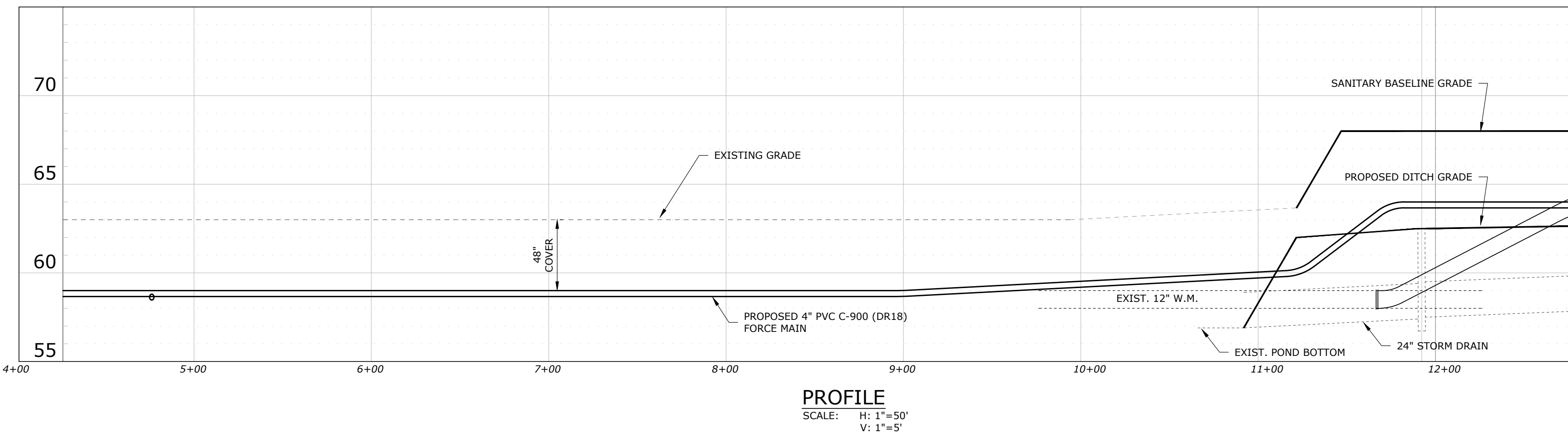
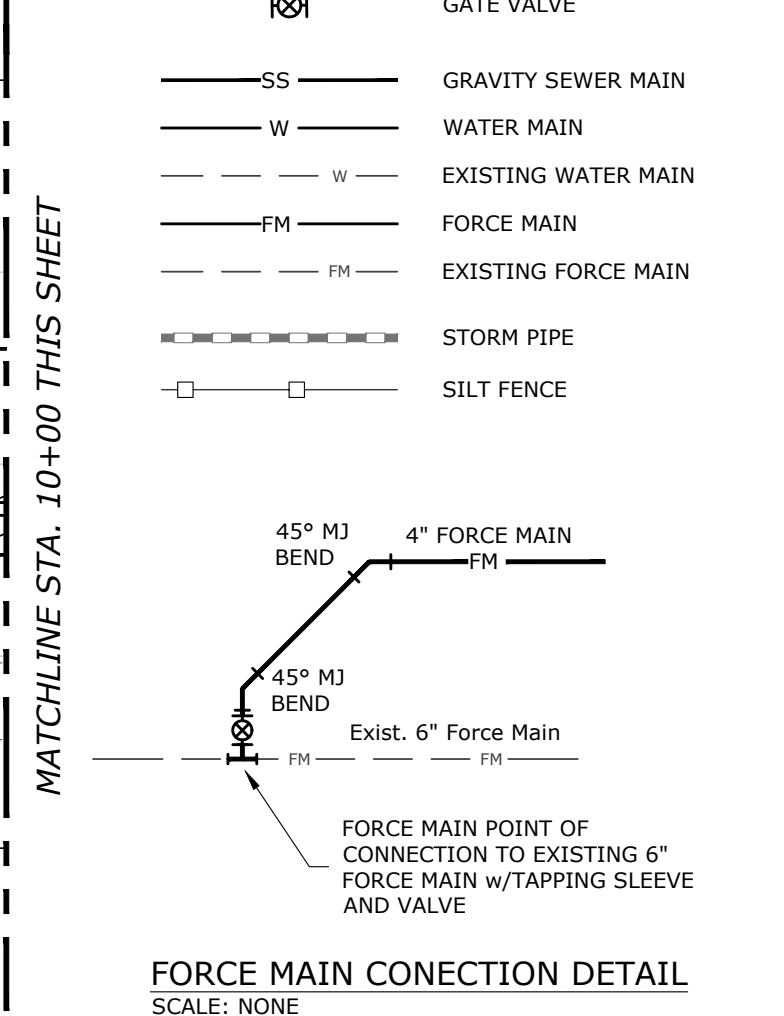
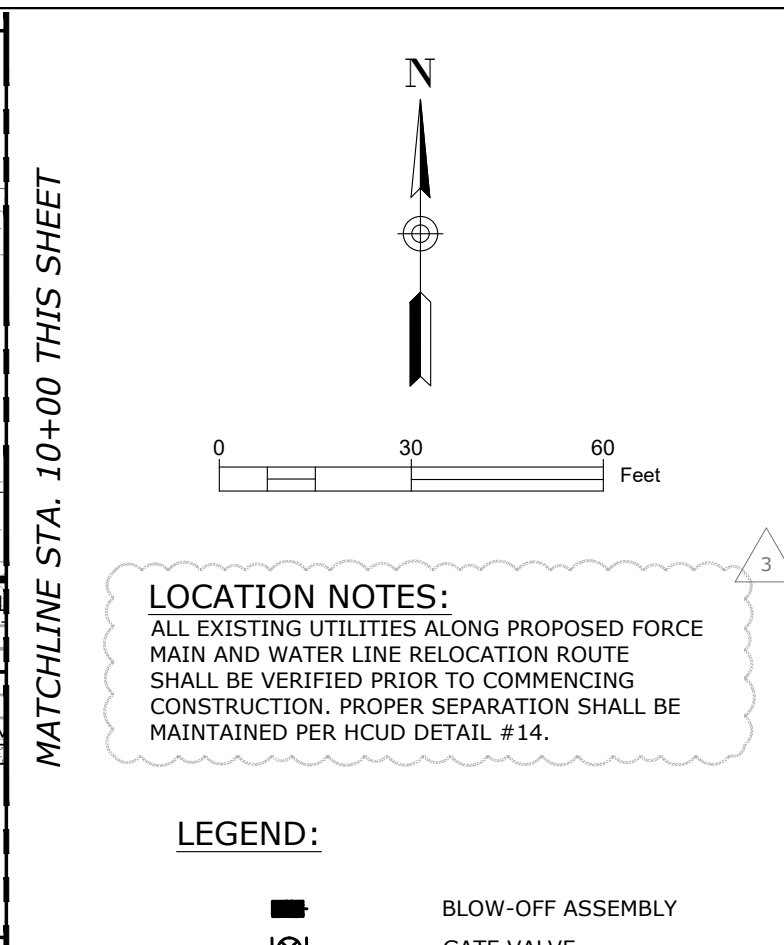
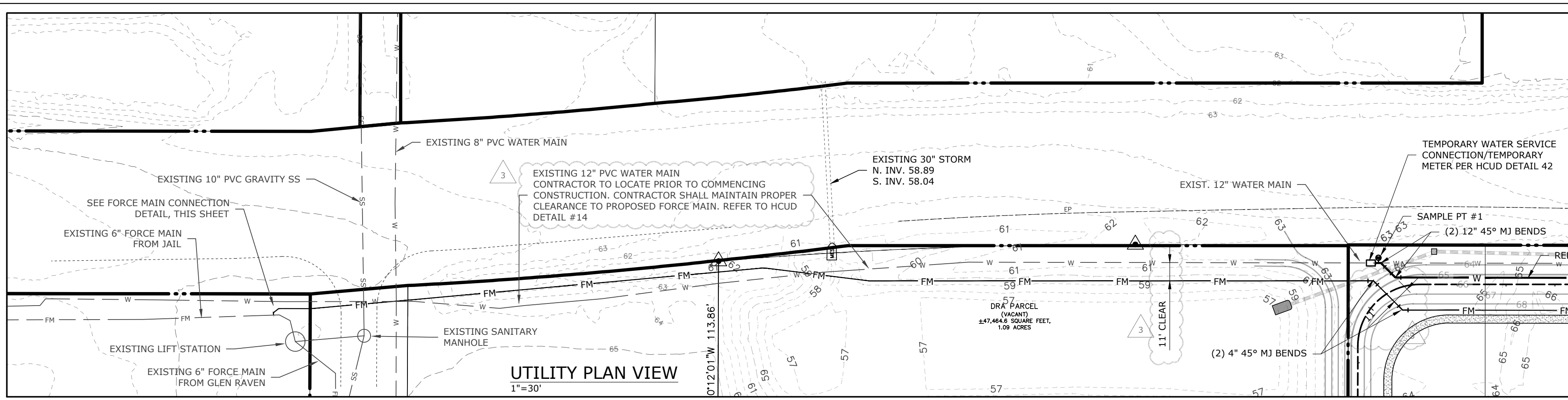

LOCATION NOTES:
ALL EXISTING UTILITIES ALONG PROPOSED FORCE MAIN AND WATER LINE RELOCATION ROUTE SHALL BE VERIFIED PRIOR TO COMMENCING CONSTRUCTION. PROPER SEPARATION SHALL BE MAINTAINED PER HCUD DETAIL #14.

- NOTES:**
- SEE NOTES ON SHEET C-02 FOR ADDITIONAL UTILITY CONSTRUCTION INFORMATION. ALL NEW UTILITIES CONSTRUCTION PROCEDURES AND MATERIALS SHALL MEET OR EXCEED HERNANDO COUNTY UTILITIES DEPARTMENT POTABLE WATER & WASTEWATER CONSTRUCTION SPECIFICATIONS MANUAL, LATEST EDITION AS AVAILABLE ON THE INTERNET AT: [HTTP://WWW.HERNANDOCOUNTY.US/DEPARTMENTS/DEPARTMENTS-N-2/UTILITIES/ENGINEERING](http://www.hernandocounty.us/departments/departments-n-2/utilities/engineering).
 - LICENSED PLUMBER SHALL MAKE ALL WATER & SEWER CONNECTIONS TO BUILDINGS.
 - SEE UTILITY DETAIL SHEETS FOR UTILITY TRENCH / PIPE BEDDING DETAIL WHICH REQUIRES INSTALLATION OF 10 GA LOCATE WIRE.
 - WATER PIPE LESS THAN 4" SHALL BE SDR 26 PVC PER ASTM D 2241 W/ GASKETED JOINTS PER ASTM D 3139. COLOR CODING OF PIPE SHALL BE WHITE OR BLUE FOR WATER WITH APPROPRIATE NSF MARKINGS, MECHANICAL RESTRAINTS OR THRUST BLOCKS SHALL BE PROVIDED AT ALL BENDS. BENDS SHALL BE 45° UNLESS APPROVED OTHERWISE. SCH80 PVC IN ACCORDANCE W/ FLORIDA PLUMBING CODE MAY BE SUBSTITUTED FOR SDR 26 PVC.
 - SHUT OFF VALVES LESS THAN 4" SHALL HAVE A FULL PORT OPENING, NON-RISING STEM WITH HAND WHEEL, THREAD TO THE END, AND RESILIENT WEDGE PER HCUD SPECIFICATIONS MANUAL SECTION 3.10.1 FOR GATE VALVES.
 - CONTRACTOR TO NOTIFY HCUD INSPECTOR 48 HOURS PRIOR TO UTILITY CONSTRUCTION IN THE COUNTY RIGHT-OF-WAY. HCUD INSPECTOR MUST BE PRESENT FOR ALL WATER AND SEWER CONNECTIONS.
 - HERNANDO COUNTY UTILITIES DEPARTMENT SHALL NOT OWN, OPERATE OR MAINTAIN ON-SITE WATER AND/OR SEWER UTILITIES LOCATED OUTSIDE OF UTILITY EASEMENTS.
 - COORDINATE LOCATION OF POTABLE WATER SAMPLE POINTS REQUIRED FOR FINAL ACCEPTANCE WITH THE ENGINEER.
 - PVC GRAVITY SEWER, WHERE USED, SHALL CONFORM TO ASTM 3034, FOR SDR 26 WITH BELL & SPIGOT JOINTS.
 - GAS, PHONE, ELECTRIC, CABLE ETC AS MAY BE REQUIRED FOR PROJECT ARE NOT SHOWN WITHIN THESE PLANS. EXCEPT FOR INFORMATION WHICH MAY BE PROVIDED IN MEP PLANS IT SHALL BE CONTRACTOR'S RESPONSIBILITY TO COORDINATE INSTALLATION OF UNDERGROUND FEATURES ASSOCIATED WITH THESE UTILITIES. ALL UTILITIES (INCLUDING WATER & SEWER) SHALL BE INSTALLED PRIOR TO BASE CONSTRUCTION & INSTALLATION OF CURBS, SIDEWALKS & ASPHALT UNLESS APPROVED OTHERWISE BY THE OWNER.
 - CONTRACTOR TO SCHEDULE A PRE-CONSTRUCTION MEETING FIVE (5) BUSINESS DAYS PRIOR TO THE START OF OFF-SITE UTILITY CONSTRUCTION. CONTRACTOR MUST PROVIDE ALL UTILITY SUBMITTALS TO THE HCUD INSPECTOR FOR REVIEW AND APPROVAL A MINIMUM OF THREE(3) BUSINESS DAYS PRIOR TO THE PRE-CONSTRUCTION MEETING. HCUD INSPECTOR MUST ATTEND THE PRE-CONSTRUCTION MEETING.
 - CONSTRUCTION WATER TO BE PROVIDED BY A TEMPORARY CONSTRUCTION WATER METER INSTALLED BY HCUD ON THE CLOSEST FIRE HYDRANT TO THE SITE. CONTRACTOR TO CONTACT HCUD'S COMMERCIAL CUSTOMER SERVICE DIVISION TO SIGN UP FOR SERVICE IF CONSTRUCTION WATER IS REQUIRED.
 - ENGINEER/DEVELOPER/CONTRACTOR OR OWNER TO COMPLETE AND DEDICATE ALL OFF-SITE WATER AND SEWER INFRASTRUCTURE TO HERNANDO COUNTY UTILITIES DEPARTMENT (HCUD). CONTACT HCUD TO OBTAIN THE CONTRIBUTED ASSET FORM.
 - HERNANDO COUNTY SHALL SUPPLY AND INSTALL THE METER BOX AND WATER METER PER HCUD SPECIFICATIONS UPON PAYMENT OF CONNECTION FEES.
 - ITEMS REQUIRED FOR HCUD FINAL INSPECTION APPROVAL (FOR CERTIFICATE OF OCCUPANCY):
A) INSTALLATION AND INSPECTION OF A HCUD APPROVED, UNIVERSITY OF SOUTHERN CALIFORNIA (USC) CERTIFIED AND UNDERWRITER LABORATORIES (UL) APPROVED REDUCED PRESSURE ZONE-BACKFLOW PREVENTION ASSEMBLY (RPZ-BPA) FOR POTABLE, IRRIGATION, AND/OR FIRE SERVICES.
1) INSTALLED PER CURRENT HCUD BACKFLOW PREVENTION ASSEMBLY RFPZ DETAIL #7 & TESTED BY A LICENSED PLUMBER WITH TEST RESULTS PROVIDED TO HCUD'S BPA INSPECTOR.
2) CONTACT HCUD BPA INSPECTOR AT (352) 754-4802 TO ARRANGE A TIME FOR INSPECTION. THIS INSPECTION IS SEPARATE FROM PLUMBING INSPECTION SCHEDULED WITH THE DEVELOPMENT (BUILDING) DEPARTMENT.
B) SUBMIT A COMPLETED CONTRIBUTED ASSET FORM WITH ITEMIZED MATERIAL COST LIST FOR REVIEW AND APPROVAL.
C) SUBMIT (2) SETS OF 24"x36" AS-BUILT DRAWINGS AND (2) SETS OF AUTOCAD AS-BUILT CD'S. AS-BUILT DATA MUST BE SHOWN ON THE ORIGINAL SITE/UTILITY PLAN SUBMITTED FOR BUILDING/PERMIT APPROVAL.
D) SUBMIT BACTERIOLOGICAL AND PRESSURE TEST, AS REQUIRED BY HCUD AND FDEP. PROVIDE COPIES OF THE SIGNED AND RECORDED UTILITY EASEMENTS, IF APPLICABLE.
 - HCUD OWNED INFRASTRUCTURE: HCUD PERSONNEL MUST BE PRESENT TO PHYSICALLY VERIFY THAT THE INSTALLATION OF ALL PIPE FITTINGS HAS BEEN DONE PER PLAN BEFORE BURYING. THESE FITTINGS SHALL INCLUDE BUT NOT LIMITED TO: COUPLINGS, RESTRAINT, TEE, 90, 45, 22, 11, AIR RELEASE AND ANY DIVERSIONS FROM A STRAIGHT PIPE RUN. THE BOXES FOR THESE INSPECTIONS SHALL BE BETWEEN 8AM AND 4 PM. IF HCUD HAS NOT INSPECTED THE FITTING BEFORE BURYING THE CONTRACTOR WILL BE RESPONSIBLE FOR UNCOVERING FOR INSPECTION.
 - ALL SITE UTILITIES TO COORDINATE WITH ARCHITECTURAL PLANS FOR LOCATION AND ROUTING OF FREE STANDING SIGN AND SITE LIGHTING.
 - THE HERNANDO COUNTY UTILITY DEPARTMENT (HCUD) IS NOT RESPONSIBLE FOR ANY ONSITE DAMAGE ASSOCIATED WITH THE NORMAL MAINTENANCE OR REPAIR OF ANY HCUD OWNED WATER &/OR SEWER INFRASTRUCTURE. THE OWNER/DEVELOPER IS RESPONSIBLE FOR ALL REPAIRS AND REPLACEMENT TO EXISTING LANDSCAPING, CURB, ASPHALT, CONCRETE, ETC.
 - PIPE RESTRAINTS TO BE INSTALLED PER MANUFACTURER AND HCUD MINIMUM REQUIREMENTS.
 - CONTRACTOR SHALL PROVIDE TEMPORARY BLOW-OFFS AT ENDS OF WATER AND SEWER MAINS.
 - SYMBOLS USED TO REPRESENT FITTINGS ARE NOT TO SCALE AND THEREFORE ARE NOT INTENDED TO SHOW EXACT LOCATIONS. THEY REPRESENT GENERAL LOCATIONS ONLY. AT OR ABOVE GRADE APPURTENANCES (SUCH AS FIRE HYDRANTS, VALVE BOXES, BLOW-OFFS, SAMPLING POINTS, ETC.) ARE NOT TO BE INSTALLED IN PAVED AREAS (INCLUDING SIDEWALKS) WITHOUT WRITTEN APPROVAL BY THE ENGINEER. FINAL LOCATIONS SHOULD BE ADJUSTED AS NECESSARY TO MEET THIS REQUIREMENT WITHOUT ALTERING INTENDED DESIGN.
 - INSTALL FITTINGS OR DEFLECT PIPE (PER MANUFACTURER'S INSTRUCTIONS) TO AVOID CONFLICT. SEE HCUD DETAIL 14 FOR MINIMUM SEPARATION.
 - RESTRAIN EXISTING WATER SYSTEM CONNECTION POINTS AS NECESSARY (AT A MINIMUM PER COUNTY PIPELINE JOINT RESTRAINT SPECIFICATION DETAIL).
 - FITTINGS SHOWN ARE FOR PLANNING AND BIDDING PURPOSES ONLY CONTRACTOR TO INSTALL FITTINGS AS NECESSARY TO MAINTAIN MINIMUM REQUIRED SEPARATIONS AND FOLLOW PROPOSED ROUTE. PIPE DEFLECTION MAY ALSO BE USED TO MEET THIS REQUIREMENT. NORTHING AND EASTING WHERE SHOWN ARE APPROXIMATE, CONTRACTOR TO FIELD VERIFY LOCATIONS.
 - ALL AFTER HOUR WORK REQUESTS MUST BE SUBMITTED TO HCUD A MINIMUM 6 BUSINESS DAYS (NOT INCLUDING PUBLIC HOLIDAYS AND WEEKENDS) PRIOR TO THE PROPOSED WORK. THE REQUEST MUST FOLLOW HCUD'S REVISED SCHEDULED AFTER HOURS WORK REQUEST SOP DATED 3-26-18 (OR LATEST EDITION). IF AFTER HOURS WORK IS PROPOSED CONTACT HCUD TO RECEIVE THE REVISED SOP PRIOR TO REQUESTING AFTER HOURS WORK.
 - FHA'S TO BE PLACED IN RIGHT-OF-WAY.
 - THE EXISTING UTILITY INFRASTRUCTURE IS SUBJECT TO FIELD VERIFICATION. VERIFICATION OF THE SIZE, LOCATION, DEPTH, MATERIAL TYPE AND ANY OTHER PERTINENT INFORMATION IS THE RESPONSIBILITY OF THE DEVELOPER/EO/CORPORATOR PRIOR TO CONSTRUCTION.
 - SEWER CLEAN-OUTS TO BE LOCATED IN CONCRETE (I.E. DRIVEWAYS, SIDEWALKS, ETC.) SHALL BE INSTALLED PER HCUD DETAIL #26.
 - CONTRACTOR TO STAKE THE UTILITY EASEMENTS/TRACTS THAT WILL CONTAIN HCUD INFRASTRUCTURE PRIOR TO INFRASTRUCTURE INSTALLATION.

UTILITY PLAN PROFILE
DR DENNIS WILFONG CENTER
FOR SUCCESS

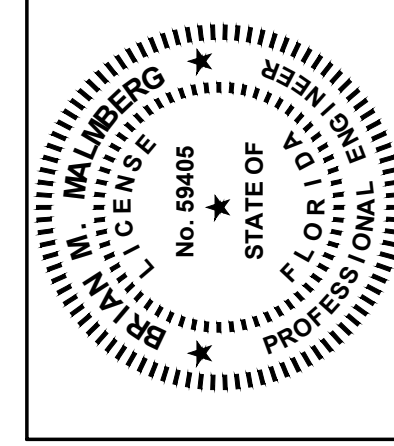

Coastal
Engineering
Surveying
Environmental
Transportation
Construction Management

966 Candlelight Boulevard - Brooksville - Florida 34601
(352) 796-9423 - Fax (352) 799-8359
EB-0000142

REUSE OF DOCUMENT
THIS DOCUMENT, COMPRISED OF THE INCORPORATED IDEAS AND THE PROFESSIONAL SERVICE IS THE PROPERTY OF COASTAL ENGINEERING ASSOCIATES, INC. IT IS NOT TO BE REPRODUCED OR USED IN ANY OTHER MANNER WITHOUT THE WRITTEN AUTHORIZATION OF COASTAL ENGINEERING ASSOCIATES, INC. DRAWING INVALED UNLESS SIGNED, DATED & SEALED BY REGISTERED PROFESSIONAL ENGINEER.

DATE	REV. BY/REV. NO.	REVISION
09/13/22	LEE	1
10-13-22	LEE	2
1-24-23	LEE	3

DATE: 02/07/2023 - 9:55am
PRINTED BY: LH
PATH: L:\21115\CITIZENS FOR SUCCESS\dwg\ENG\Curren21115_SP.dwg

WHEN PRINTED TO SCALE, DRAWING SIZE SHALL BE 22" X 34"

SHEET
C-13

JOB No: 21115

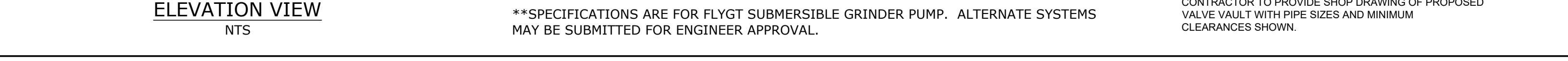
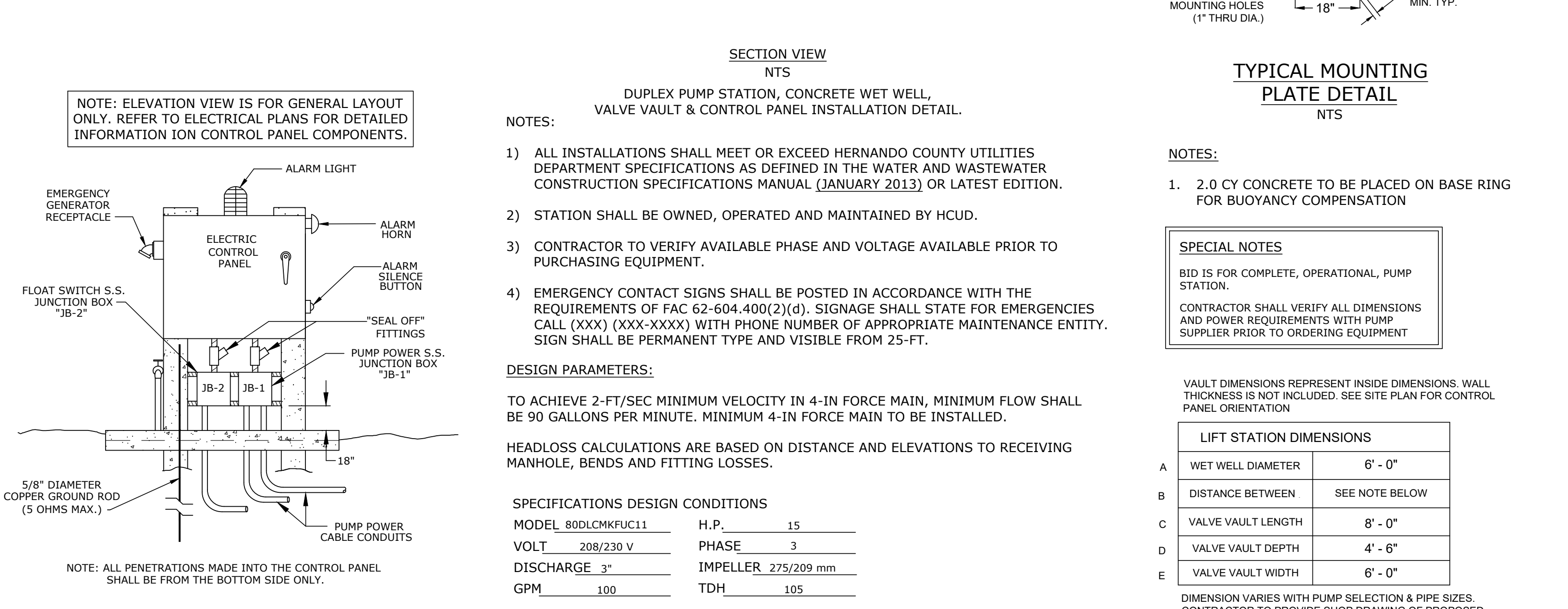
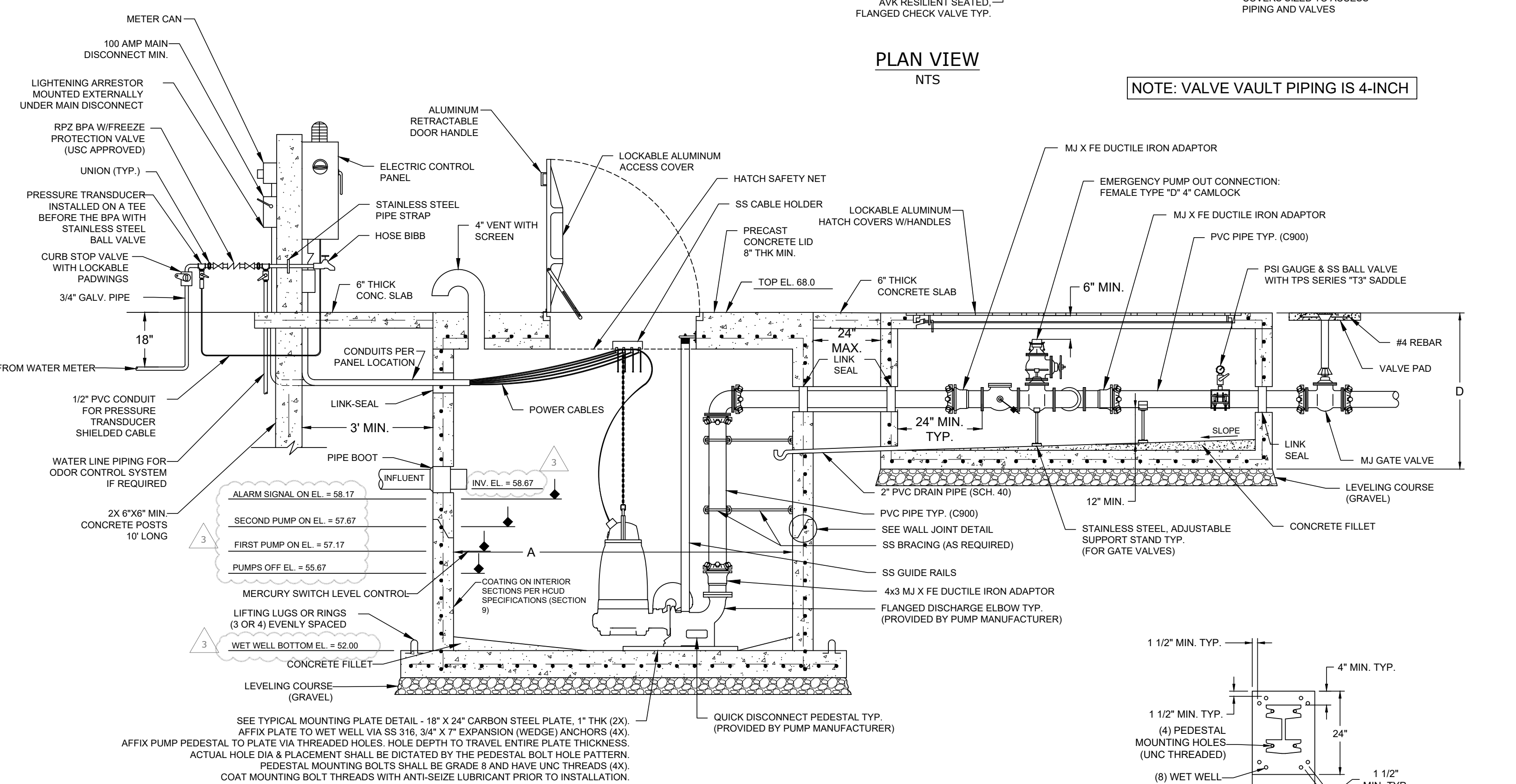
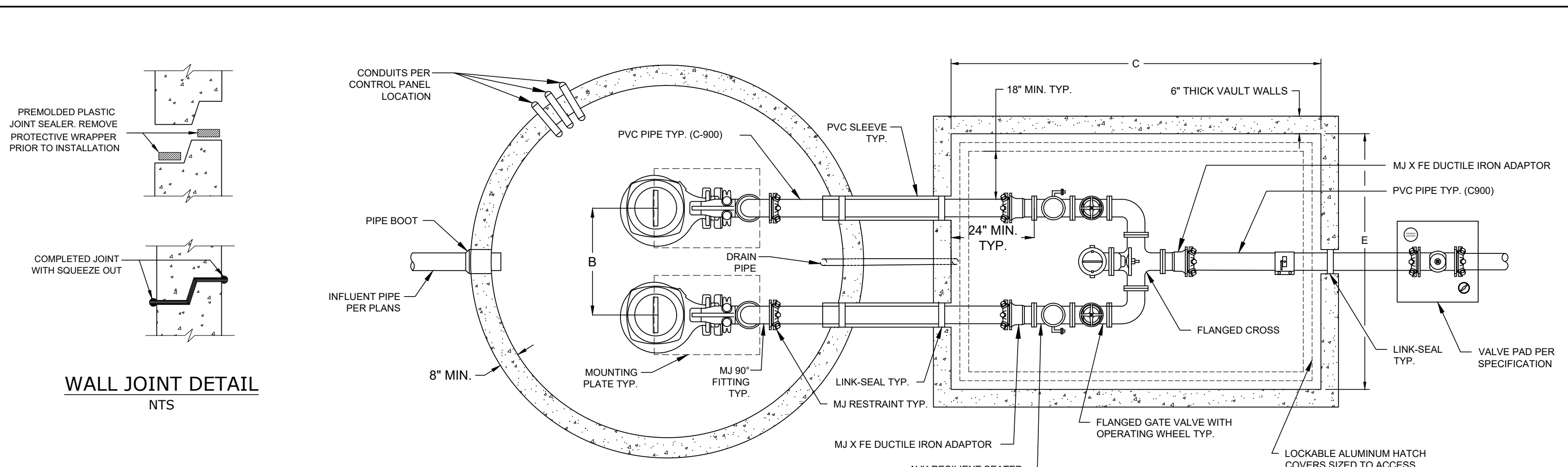

NOTE: ELEVATION VIEW IS FOR GENERAL LAYOUT ONLY. REFER TO ELECTRICAL PLANS FOR DETAILED INFORMATION ION CONTROL PANEL COMPONENTS.

- NOTES:
- 1) ALL INSTALLATIONS SHALL MEET OR EXCEED HERNANDO COUNTY UTILITIES DEPARTMENT SPECIFICATIONS AS DEFINED IN THE WATER AND WASTEWATER CONSTRUCTION SPECIFICATIONS MANUAL (JANUARY 2013) OR LATEST EDITION.
 - 2) STATION SHALL BE OWNED, OPERATED AND MAINTAINED BY HCUD.
 - 3) CONTRACTOR TO VERIFY AVAILABLE PHASE AND VOLTAGE AVAILABLE PRIOR TO PURCHASING EQUIPMENT.
 - 4) EMERGENCY CONTACT SIGNS SHALL BE POSTED IN ACCORDANCE WITH THE REQUIREMENTS OF FAC 62-604.400(2)(d). SIGNAGE SHALL STATE FOR EMERGENCIES CALL (XXX) (XXX-XXXX) WITH PHONE NUMBER OF APPROPRIATE MAINTENANCE ENTITY. SIGN SHALL BE PERMANENT TYPE AND VISIBLE FROM 25-FT.

DESIGN PARAMETERS:

TO ACHIEVE 2-FY/SEC MINIMUM VELOCITY IN 4-IN FORCE MAIN, MINIMUM FLOW SHALL BE 90 GALLONS PER MINUTE. MINIMUM 4-IN FORCE MAIN TO BE INSTALLED.

HEADLOSS CALCULATIONS ARE BASED ON DISTANCE AND ELEVATIONS TO RECEIVING MANHOLE, BENDS AND FITTING LOSSES.

SPECIFICATIONS DESIGN CONDITIONS

MODEL	80DLCMKFUC11	H.P.	15
VOLT	208/230 V	PHASE	3
DISCHARGE	3"	IMPELLER	275/209 mm
GPM	100	TDH	105

**SPECIFICATIONS ARE FOR FLYGT SUBMERSIBLE GRINDER PUMP. ALTERNATE SYSTEMS MAY BE SUBMITTED FOR ENGINEER APPROVAL.



- NOTES:
1. 2.0 CY CONCRETE TO BE PLACED ON BASE RING FOR BUOYANCY COMPENSATION

SPECIAL NOTES

BID IS FOR COMPLETE, OPERATIONAL, PUMP STATION.

CONTRACTOR SHALL VERIFY ALL DIMENSIONS AND POWER REQUIREMENTS WITH PUMP SUPPLIER PRIOR TO ORDERING EQUIPMENT

Vault Dimensions represent inside dimensions. Wall thickness is not included. See site plan for control panel orientation

LIFT STATION DIMENSIONS	
A	WET WELL DIAMETER 6' - 0"
B	DISTANCE BETWEEN SEE NOTE BELOW
C	VALVE VAULT LENGTH 8' - 0"
D	VALVE VAULT DEPTH 4' - 6"
E	VALVE VAULT WIDTH 6' - 0"

DIMENSION VARIES WITH PUMP SELECTION & PIPE SIZES. CONTRACTOR TO PROVIDE SHOP DRAWING OF PROPOSED VALVE VAULT WITH PIPE SIZES AND MINIMUM CLEARANCES SHOWN.

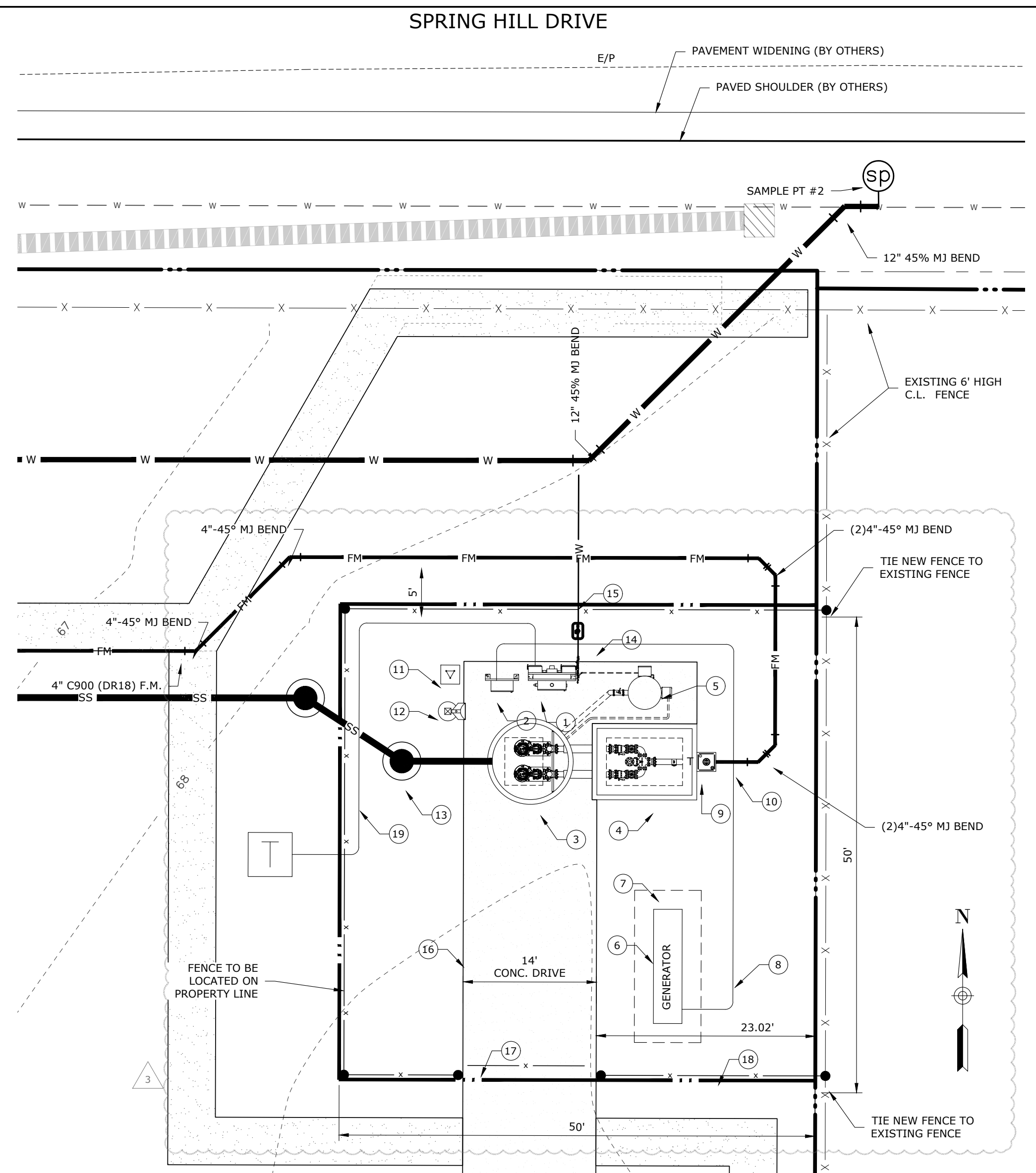

LEGEND:

1. PUMP CONTROL PANEL, ELECTRIC SERVICE AND WATER SERVICE PER PLANS AND SPECIFICATIONS.
2. TRANSFER SWITCH FOR GENERATOR PER PLANS AND SPECIFICATIONS, IF APPLICABLE.
3. WET WELL PER PLANS AND SPECIFICATIONS. ALSO SEE NOTE #21 BELOW.
4. VALVE VAULT PER PLANS AND SPECIFICATIONS.
5. ODOR CONTROL SYSTEM PER PLANS AND SPECIFICATIONS, IF APPLICABLE.
6. GENERATOR PER PLANS AND SPECIFICATIONS, IF APPLICABLE. NOTE: IF DIESEL DRIVEN PUMP IS USED IN LIEU OF GENERATOR, SEE STANDBY DIESEL DRIVEN PUMP DETAIL.
7. CONCRETE SUPPORT PAD FOR GENERATOR PER PLANS AND SPECIFICATIONS, IF APPLICABLE.
8. CONDUITS AND WIRING TO TRANSFER SWITCH FROM GENERATOR PER PLANS AND SPECIFICATIONS.
9. FORCE MAIN VALVE AND CONCRETE DRIVEWAY PAD PER PLANS AND SPECIFICATIONS.
10. FORCE MAIN PER PLANS AND SPECIFICATIONS.
11. DATA FLOW SYSTEMS ANTENNA AND CONCRETE SUPPORT PAD.
12. SITE LIGHTING, POLE AND CONCRETE BASE PER PLANS AND SPECIFICATIONS.
13. COLLECTOR MANHOLE PER PLANS AND SPECIFICATIONS.
14. HCUD WATER METER AND METER BOX.
15. POLY TUBING WATER SERVICE LINE WITH #10 AWG LOCATE WIRE FROM WATER MAIN PER PLANS AND SPECIFICATIONS.
16. 14' WIDE 4000 PSI WITH WIRE, CONCRETE DRIVEWAY PER PLANS AND SPECIFICATIONS.
17. SINGLE CANTILEVER SLIDE GATE (NO WHEELS ON BOTTOM) PER PLANS AND SPECIFICATIONS.
18. 50' X 50' FENCED PUMP STATION SITE PER PLANS AND SPECIFICATIONS. CONSTRUCT FENCE AND GATE PER DETAIL 39 ON SHEET C-15
19. CONDUIT AND WIRING FROM THE POWER COMPANY TRANSFORMER TO THE ELECTRIC SERVICE ON THE CONTROL PANEL PER PLANS AND SPECIFICATIONS.

- NOTES:
20. CONTRACTOR TO PROVIDE WASTEWATER PUMP STATION GENERATOR DEDICATED TO HCUD: CONTRACTOR TO SUBMIT A COMPLETED CERTIFICATION FOR ELECTRICAL GENERATOR APPLICATION FOR REVIEW: [HTTPS://WWW.HERNANDOCOUNTY.US/HOME/SHOWPUBLISHEDDOCUMENT/7562/637825867590569124](https://www.hernandocounty.us/home/showpublisheddocument/7562/637825867590569124).
 21. DO NOT CENTER THE WET WELL ON THE PUMP STATION SITE. THE SINGLE CANTILEVER SLIDE GATE CAN NOT BE INSTALLED PROPERLY IF IT IS CENTERED. THE SINGLE CANTILEVER GATE REQUIRES A MINIMUM OF 21' IN THE OPEN POSITION.
 22. THE FINISH CONCRETE SLAB ELEVATION OF THE TOP OF THE WET WELL AND VALVE VAULT SHALL BE AT OR ABOVE THE 100 YEAR FLOOD ELEVATION OR A MINIMUM OF ONE FOOT ABOVE THE CROWN OF THE ROAD IN FRONT OF THE PUMP STATION SITE, WHICHEVER IS GREATER.
 23. THIS IS A TYPICAL LAYOUT, OTHER FACTORS DURING DESIGN MAY ALTER THIS LAYOUT. FINAL LAYOUT CONFIGURATION SHALL BE APPROVED BY HCUD.
 24. PUMP STATION SHALL INCLUDE TELEMETRY PER HCUD SPECIFICATIONS.
 25. CONTRACTOR TO STAKE THE UTILITY EASEMENTS/TRACTS THAT WILL CONTAIN HCUD OWNED INFRASTRUCTURE DURING CONSTRUCTION AND MAINTAIN THE STAKING UNTIL THE INFRASTRUCTURE IS INSTALLED.
 26. REFER TO SUBSECTIONS 4D.1, 4D.5 AND DETAIL 40 ON SHEET C-15 FOR ADDITIONAL INFORMATION.

LIIFT STATION DETAILS (1)

DR DENNIS WILFONG CENTER FOR SUCCESS

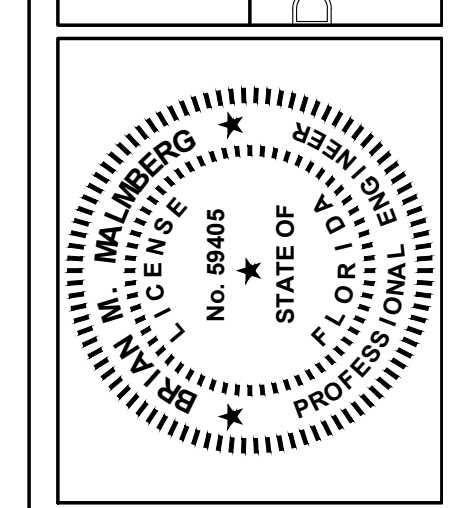

Coastal Engineering Associates, Inc.

966 Candlelight Boulevard - Brooksville - Florida 34601

(352) 796-9423 - Fax (352) 799-8359

EE-0000142

REUSE OF DOCUMENT

THIS DOCUMENT, COMPRISED OF THE INCORPORATED IDEAS AND PROFESSIONAL SERVICE IS THE PROPERTY OF COASTAL ENGINEERING ASSOCIATES, INC. IT IS NOT TO BE USED IN WHOLE OR IN PART FOR ANY OTHER PURPOSE WITHOUT THE WRITTEN AUTHORIZATION OF COASTAL ENGINEERING ASSOCIATES, INC. UNLESS SIGNED, DATED & SEALED BY REGISTERED PROFESSIONAL ENGINEER.

DATE	REV.	BY/REV. NO.	BID SET	REVISION
09/19/22	1	LEE	1	ADDRESS HCUD COMMENTS ADJUST UTIL/STORH
10-19-22	2	LEE	2	ADDRESS HCUD COMMENTS, ADD ALT BID SIDEWALK
1-24-23	3	LEE	3	

WHEN PRINTED TO SCALE, DRAWING SIZE SHALL BE 22" X 34"

SHEET

C-14

21115

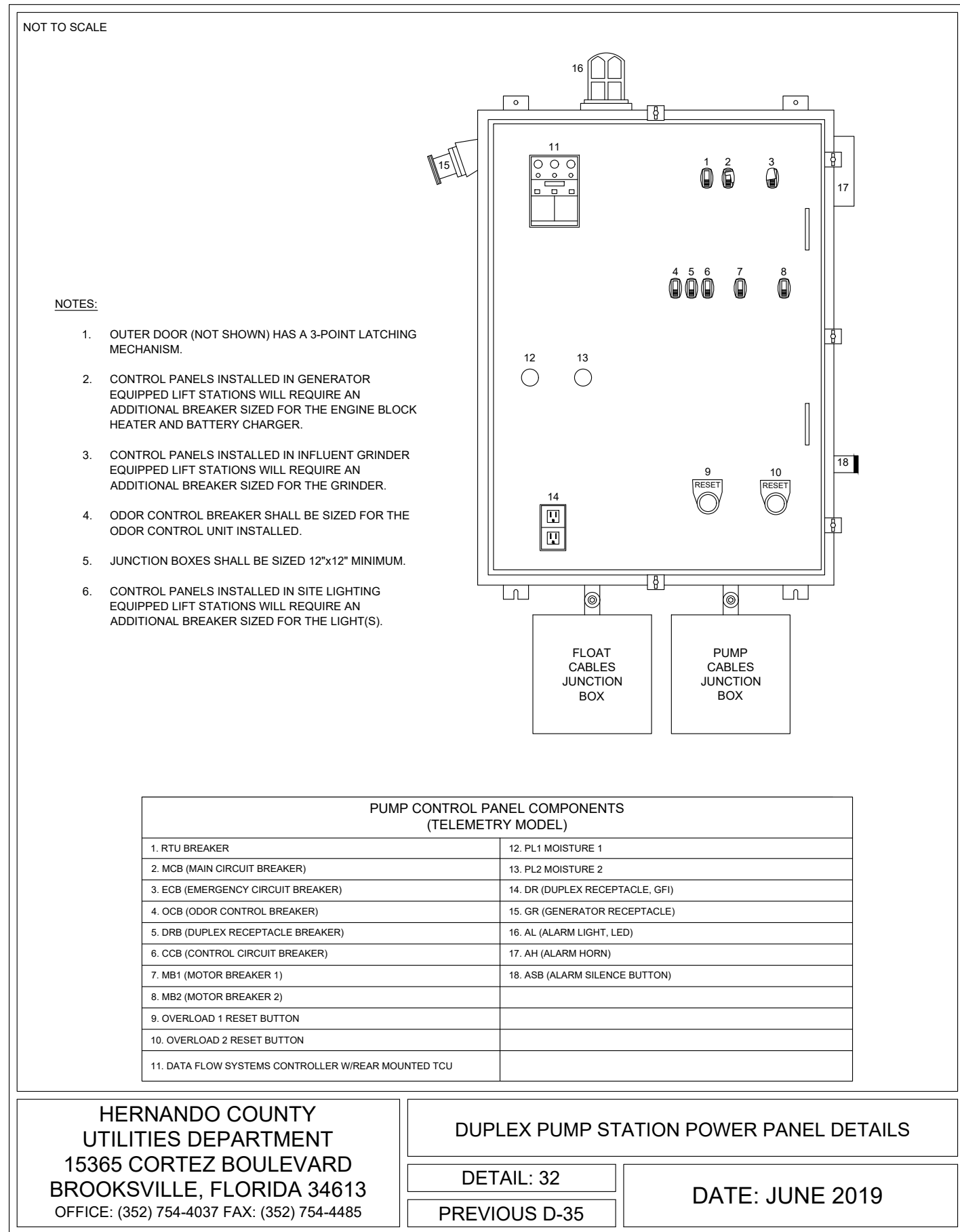

HERNANDO COUNTY UTILITIES DEPARTMENT
 15365 CORTEZ BOULEVARD
 BROOKSVILLE, FLORIDA 34613
 OFFICE: (352) 754-4037 FAX: (352) 754-4485

DUPLEX PUMP STATION POWER PANEL DETAILS

DETAIL: 32
 PREVIOUS D-35

DATE: JUNE 2019

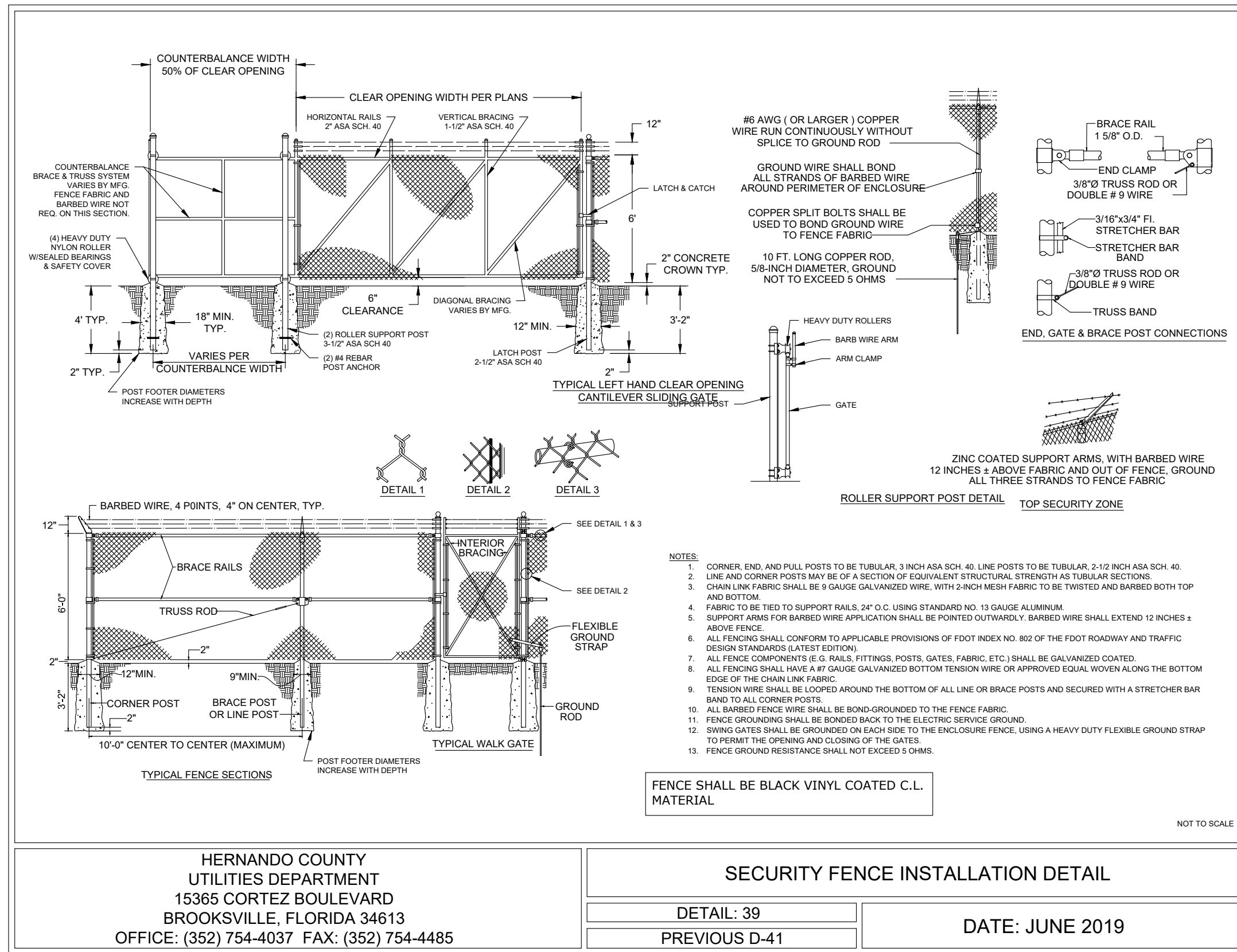

HERNANDO COUNTY UTILITIES DEPARTMENT
 15365 CORTEZ BOULEVARD
 BROOKSVILLE, FLORIDA 34613
 OFFICE: (352) 754-4037 FAX: (352) 754-4485

SECURITY FENCE INSTALLATION DETAIL

DETAIL: 39
 PREVIOUS D-41

DATE: JUNE 2019

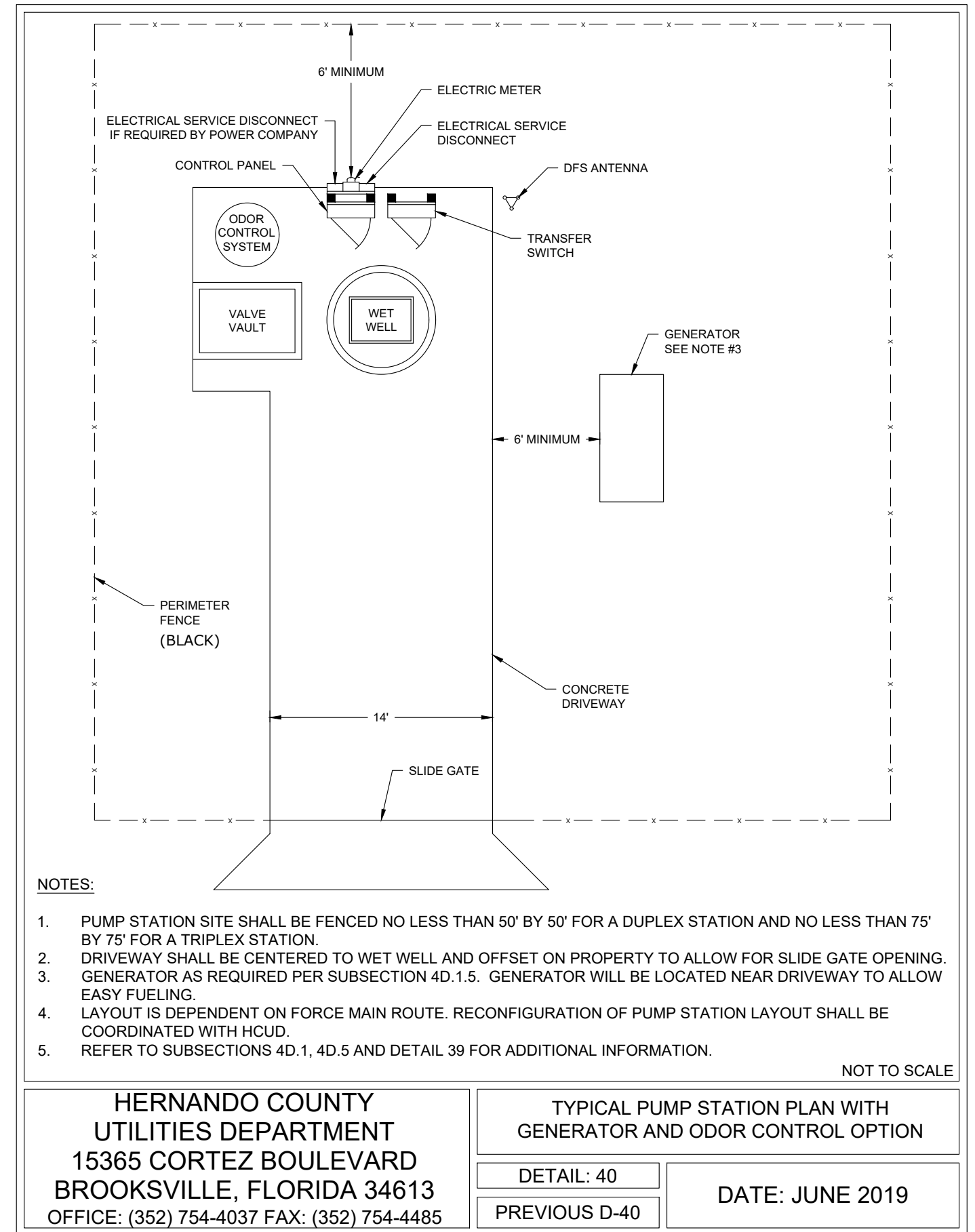

HERNANDO COUNTY UTILITIES DEPARTMENT
 15365 CORTEZ BOULEVARD
 BROOKSVILLE, FLORIDA 34613
 OFFICE: (352) 754-4037 FAX: (352) 754-4485

TYPICAL PUMP STATION PLAN WITH GENERATOR AND ODOR CONTROL OPTION

DETAIL: 40
 PREVIOUS D-40

DATE: JUNE 2019

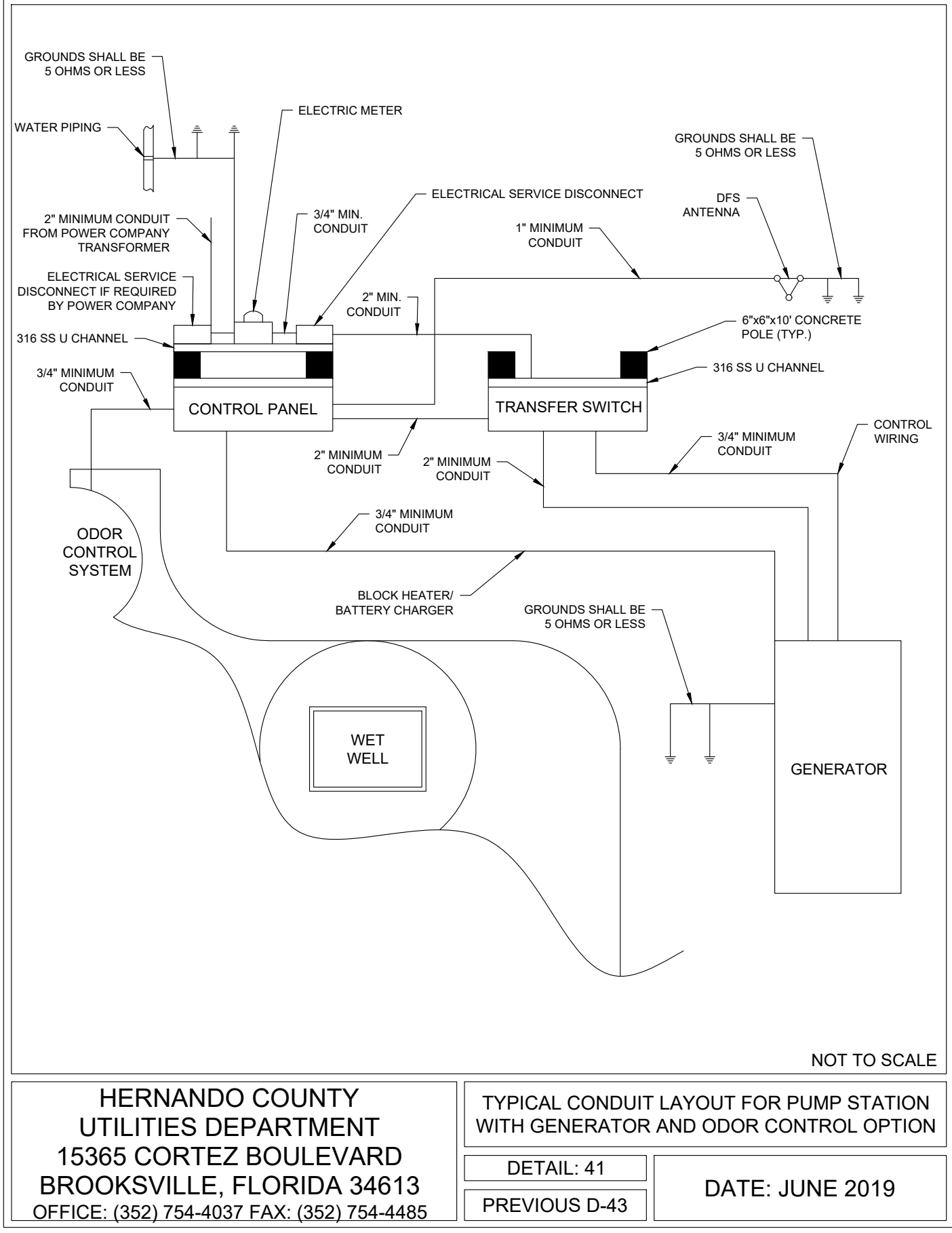

HERNANDO COUNTY UTILITIES DEPARTMENT
 15365 CORTEZ BOULEVARD
 BROOKSVILLE, FLORIDA 34613
 OFFICE: (352) 754-4037 FAX: (352) 754-4485

TYPICAL CONDUIT LAYOUT FOR PUMP STATION WITH GENERATOR AND ODOR CONTROL OPTION

DETAIL: 41
 PREVIOUS D-43

DATE: JUNE 2019

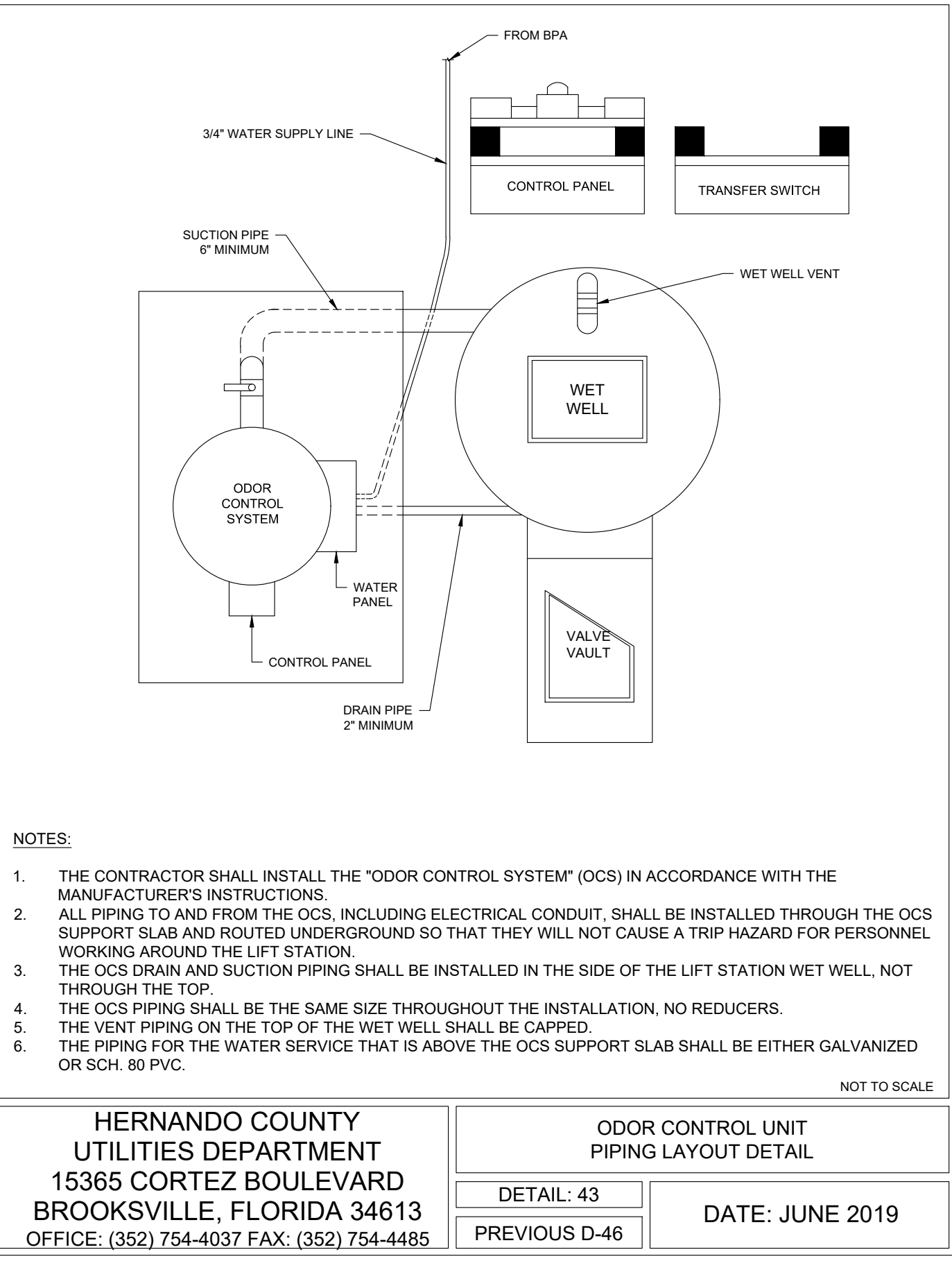

HERNANDO COUNTY UTILITIES DEPARTMENT
 15365 CORTEZ BOULEVARD
 BROOKSVILLE, FLORIDA 34613
 OFFICE: (352) 754-4037 FAX: (352) 754-4485

ODOR CONTROL UNIT PIPING LAYOUT DETAIL

DETAIL: 43
 PREVIOUS D-46

DATE: JUNE 2019

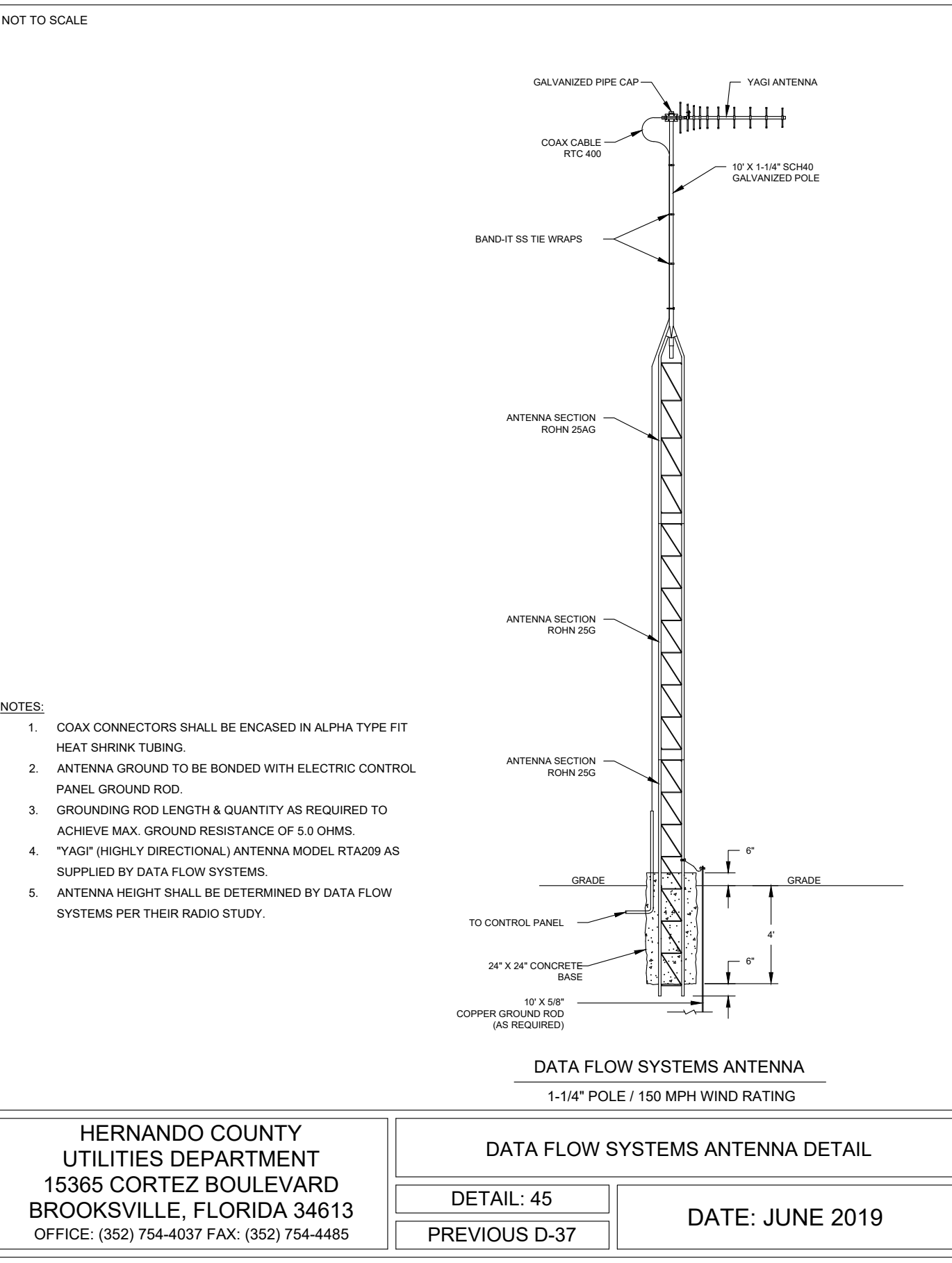

HERNANDO COUNTY UTILITIES DEPARTMENT
 15365 CORTEZ BOULEVARD
 BROOKSVILLE, FLORIDA 34613
 OFFICE: (352) 754-4037 FAX: (352) 754-4485

DATA FLOW SYSTEMS ANTENNA DETAIL

DETAIL: 45
 PREVIOUS D-37

DATE: JUNE 2019

LIFT STATION DETAILS (2)

DR DENNIS WILFONG CENTER FOR SUCCESS

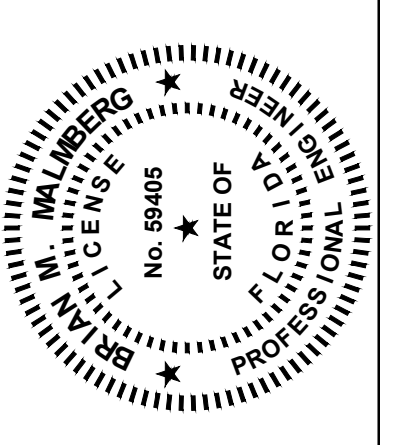

Coastal
 Engineering
 Planning
 Environmental
 Transportation
 Construction Management

966 Candlelight Boulevard - Brooksville, Florida 34601
 (352) 796-9423 - Fax (352) 796-8359
 EE-0000142

REUSE OF DOCUMENT

THIS DOCUMENT, COMPRISED OF THE INFORMATION CONTAINED HEREIN, IS THE PROPERTY OF COASTAL ENGINEERING ASSOCIATES, INC. AND IS NOT TO BE REPRODUCED, COPIED, OR TRANSMITTED IN ANY FORM OR BY ANY MEANS, WITHOUT THE WRITTEN PERMISSION OF COASTAL ENGINEERING ASSOCIATES, INC. DRAWINGS, INQUIRY, ANALYSIS, DESIGN, AND SEALING BY REGISTERED PROFESSIONAL ENGINEERS.

DATE	REV. BY/REV. NO.	REVISION
09/13/22	LEE	1. BID SET
10-13-22	LEE	2. ADDRESS HCUD COMMENTS ADJUST UTIL/STORM LOCATIONS ON SH. DRIVE
1-24-23	LEE	3. ADDRESS HCUD COMMENTS, ADD ALT BID SIDEWALK

WHEN PRINTED TO SCALE, DRAWING SIZE SHALL BE 22" X 34"

SHEET C-15

JOB No. 21115

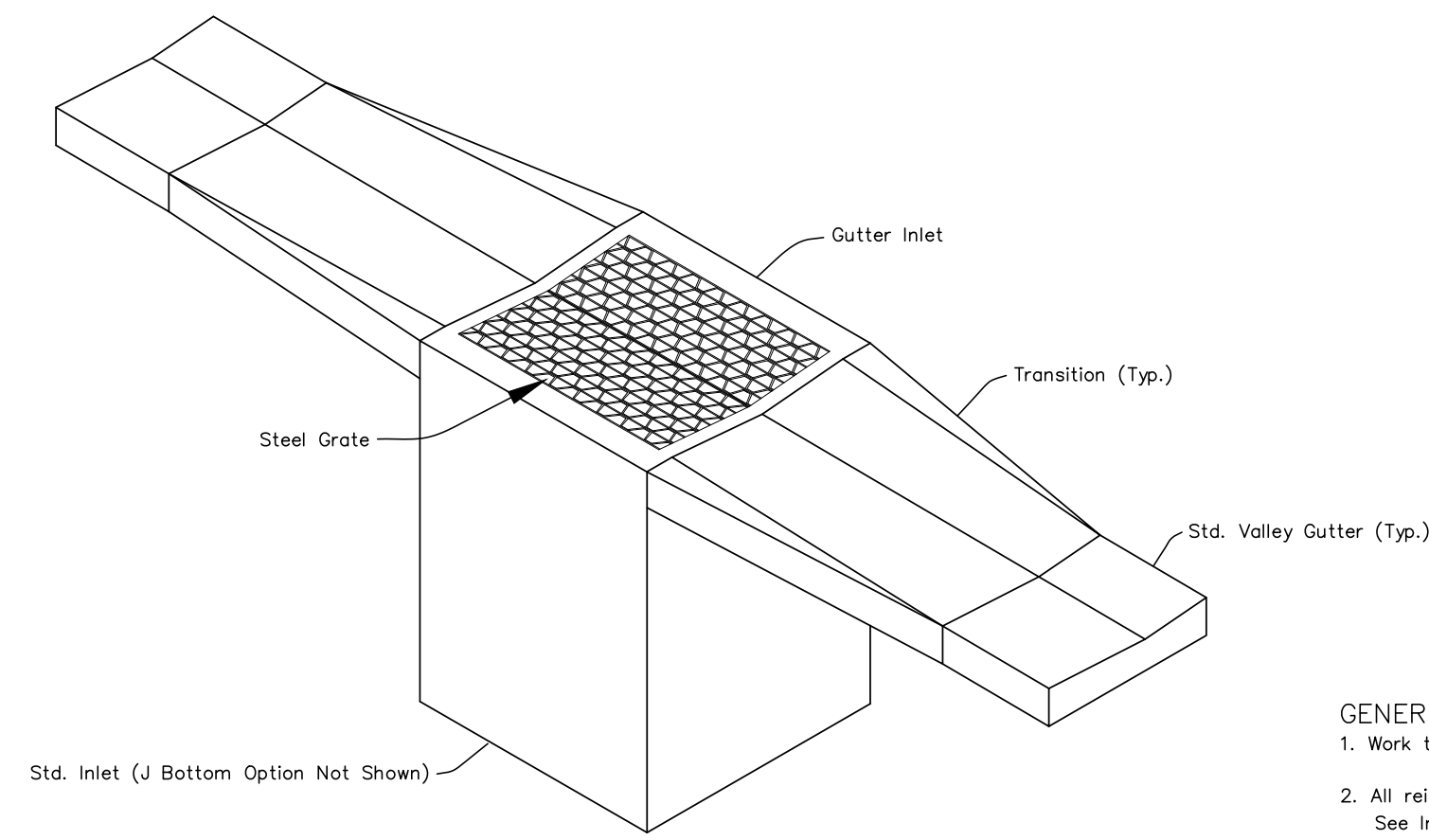

GUTTER INLET TYPE V
(Pipe Opening Not Shown)

- GENERAL NOTES:
1. Work this index with Index 425-001 and Index 425-010.
 2. All reinforcing is Grade 60 bars with 2" min. cover unless otherwise noted. See Index 425-001 for equivalent area of welded wire fabric. Cut or bend bars out of way of pipe to clear pipe 1/2".
 3. Chamfer all exposed edges and corners 3/8" or tool to 1/4" radius.
 4. Dimensions are for both precast and cast-in-place inlets unless otherwise noted.

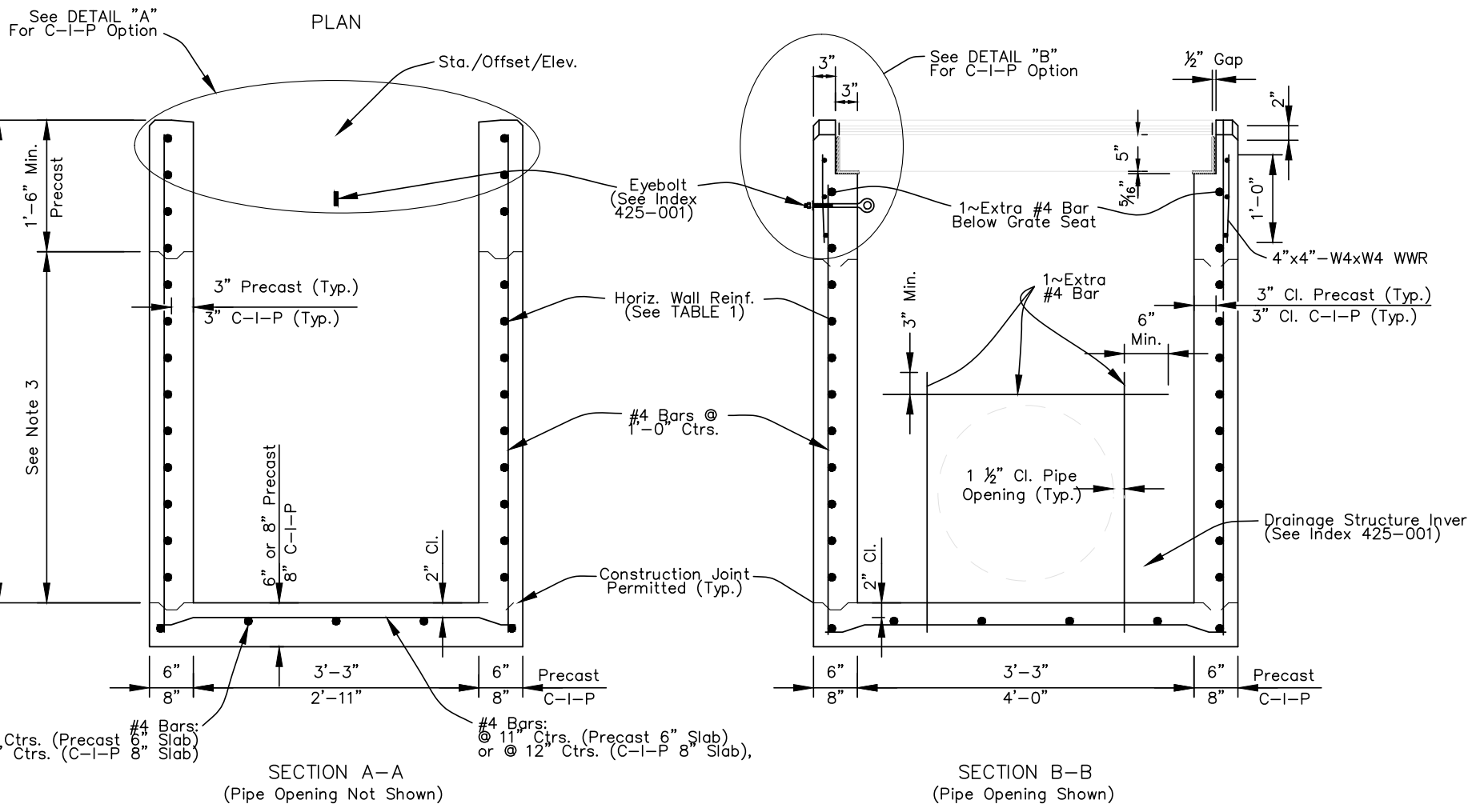
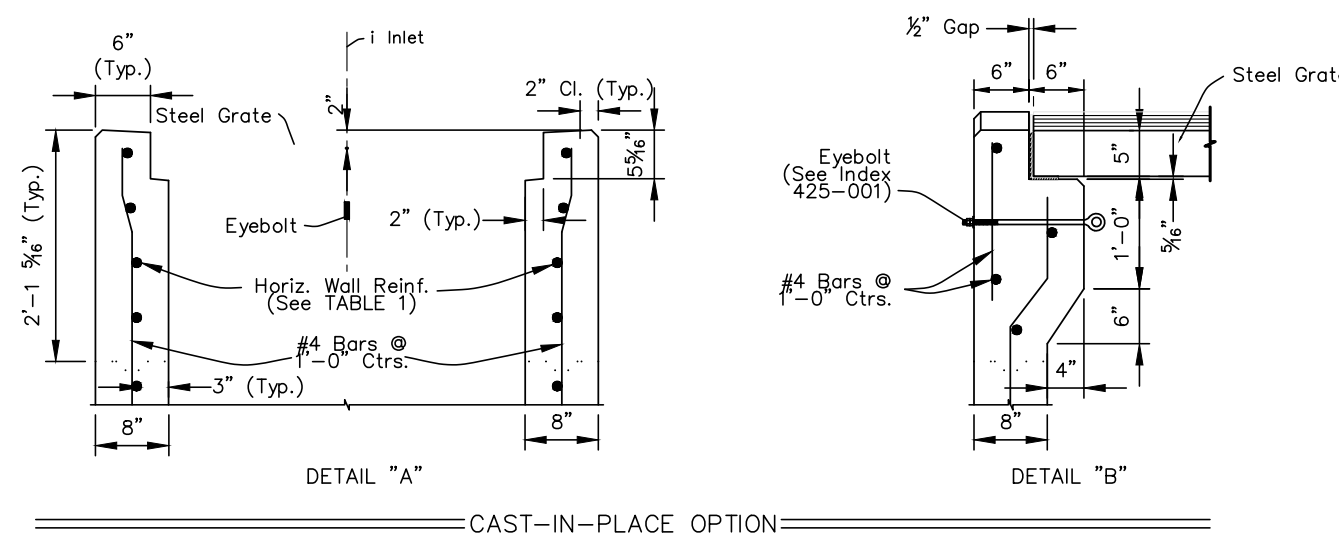
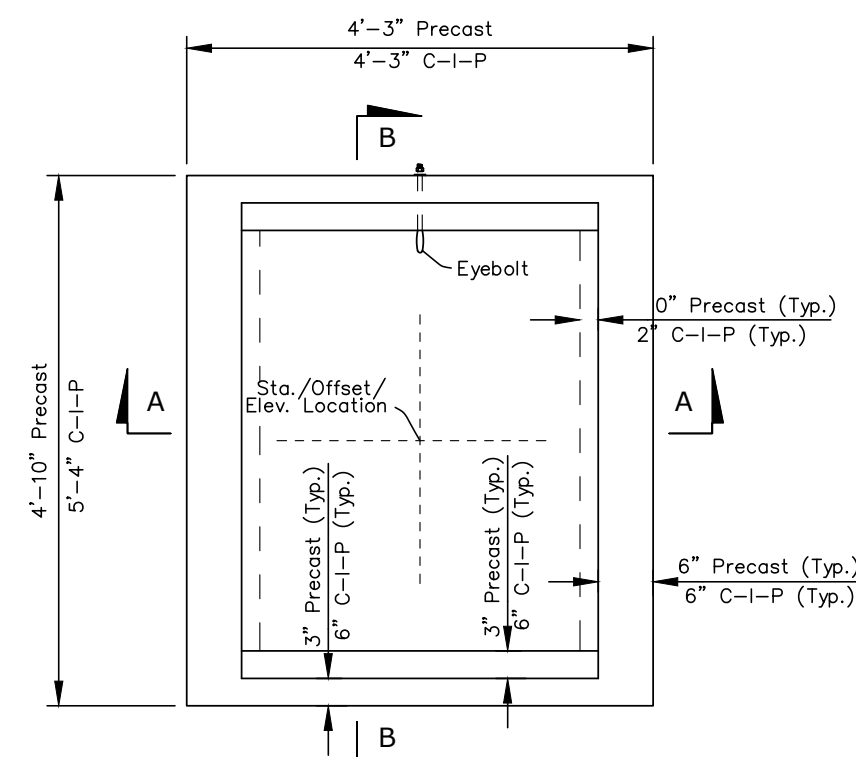

DIMENSIONAL AND REINFORCING DETAILS

FDOT INDEX 425-041 GUTTER INLET TYPE V

WALL DEPTH	SCHEDULE	AREA (in. ² /ft.)	MAX. SPACING	
			BARs	WWR
0' - 5'	A12	0.20	12"	8"
5' - 9'	A6	0.20	6"	5"
9' - 12'	A4	0.20	4"	3"
9' - 15'	B5.5	0.24	5 1/2"	5"

- NOTES:
1. Plan View: Grate, Concrete Ditch Pavement, and Sod not shown on structure detail.
 2. Precast Shown, Cast-in-Place (C-I-P) similar.
 3. Construction joints permitted between these limits. See Index 425-001 for minimum dimensions.

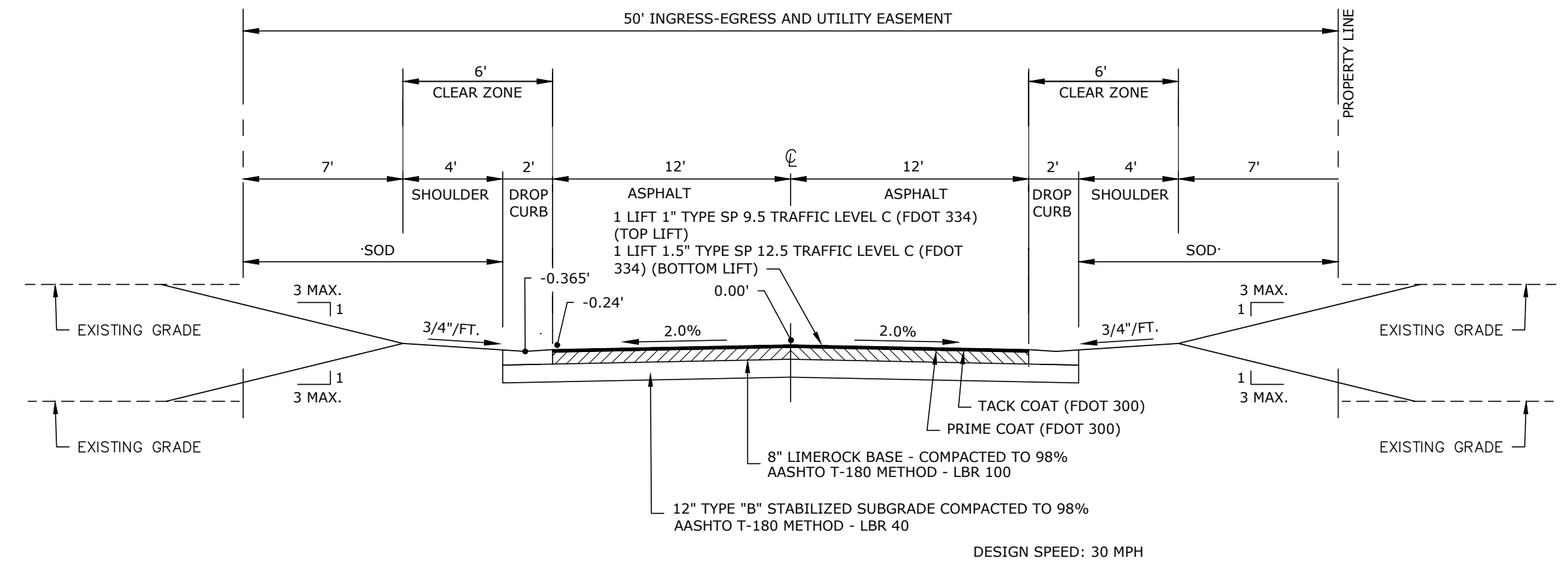

TYPICAL PAVEMENT SECTION

NTS

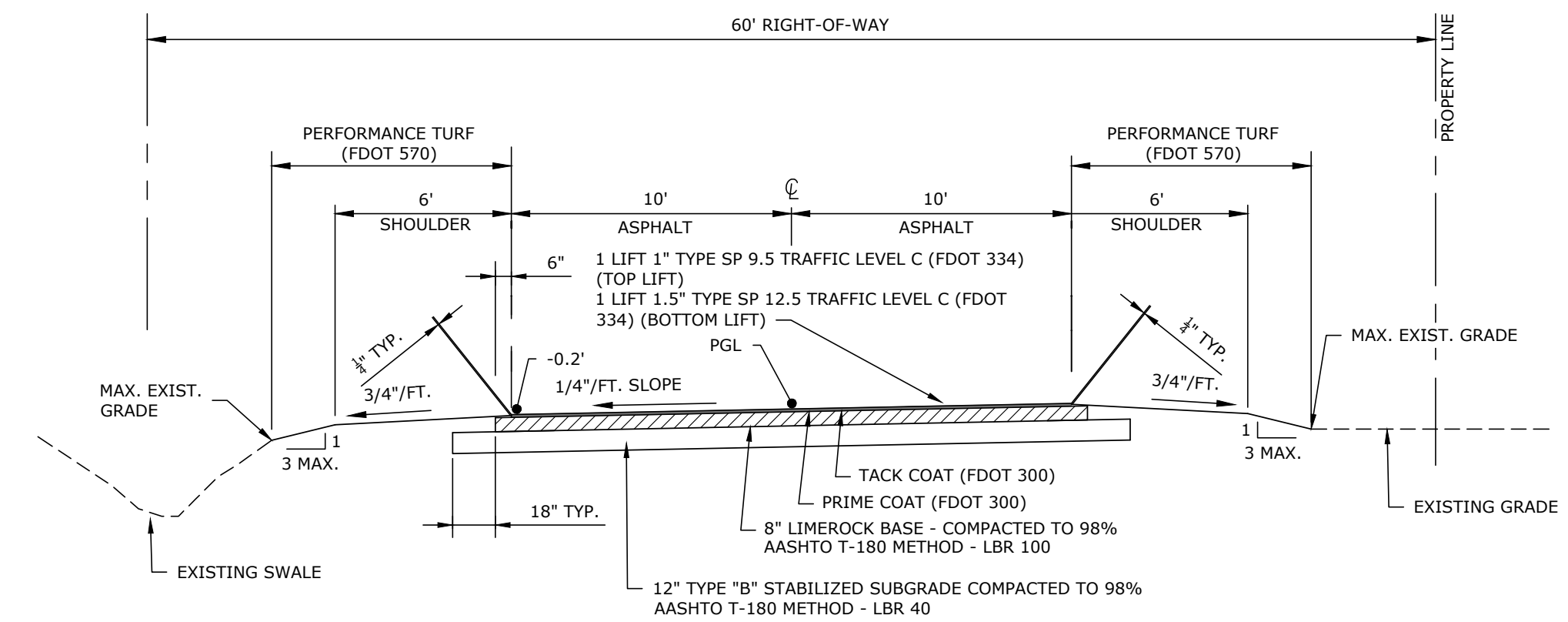

HELICOPTER DRIVE TYPICAL SECTION

NTS

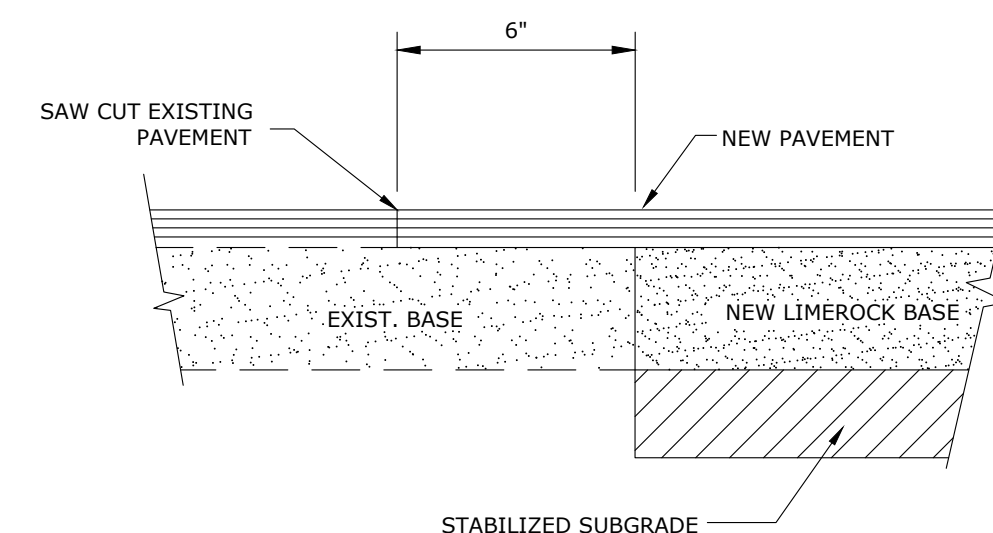

- NOTE:
CONTRACTOR SHALL MAKE A SMOOTH VERTICAL CUT IN THE EXISTING PAVEMENT AT A DISTANCE NOT LESS THAN 6" FROM THE EXISTING EDGE. THE EXISTING LIMEROCK BASE SHALL BE EXPOSED AND CLEANED TO REMOVE LOOSE PARTICLES. THE EXPOSED LIMEROCK SHALL THEN BE PRIME COATED NOT MORE THAN THREE DAYS PRIOR TO SCHEDULED PAVING.

PAVEMENT ABUTMENT DETAIL

N.T.S.

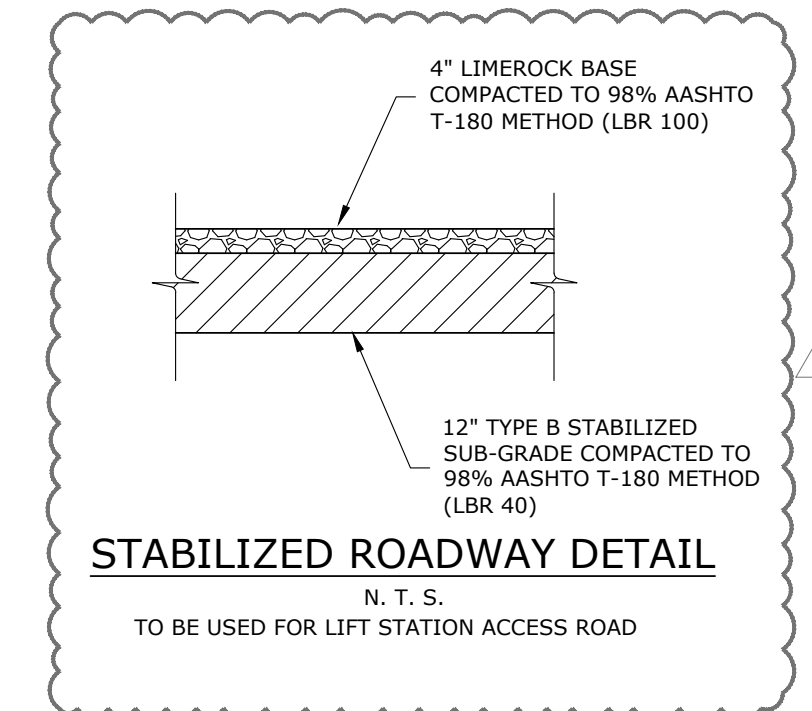

STABILIZED ROADWAY DETAIL

N. T. S.

TO BE USED FOR LIFT STATION ACCESS ROAD

DRAINAGE AND PAVING
DETAILS 1

DR DENNIS WILFONG CENTER
FOR SUCCESS

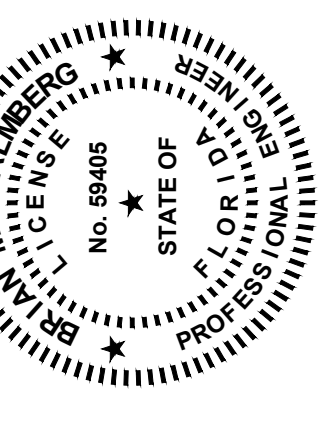

Engineering
Surveying
Environmental
Transportation
Communication Management
engineering associates, inc.
966 Candlelight Boulevard - Brooksville - Florida 34601
(352) 796-9423 - Fax (352) 799-8359
EB-0000142

REUSE OF DOCUMENT
THIS DOCUMENT IS THE PROPERTY OF ENGINEERING ASSOCIATES, INC. AND IS NOT TO BE REPRODUCED OR TRANSMITTED IN ANY FORM OR BY ANY MEANS, ELECTRONIC OR MECHANICAL, INCLUDING PHOTOCOPYING, RECORDING, OR BY ANY INFORMATION STORAGE AND RETRIEVAL SYSTEM. WITHOUT THE WRITTEN PERMISSION OF COASTAL ENGINEERING ASSOCIATES, INC. DRAWING INVALID UNLESS SIGNED, DATED & SEALED BY REGISTERED PROFESSIONAL

DATE	REV. BY/REV. NO.	REVISION
09/13/22	LEE 1	BID SET
10-13-22	LEE 2	ADDRESS H/CID COMMENTS ADJUST UTIL/STORM ADDRESS H/CID COMMENTS; ADD ALT BID SIDEWALK
1-24-23	LEE 3	

WHEN PRINTED TO SCALE, DRAWING SIZE SHALL BE 22" X 34"

SHEET
C-16

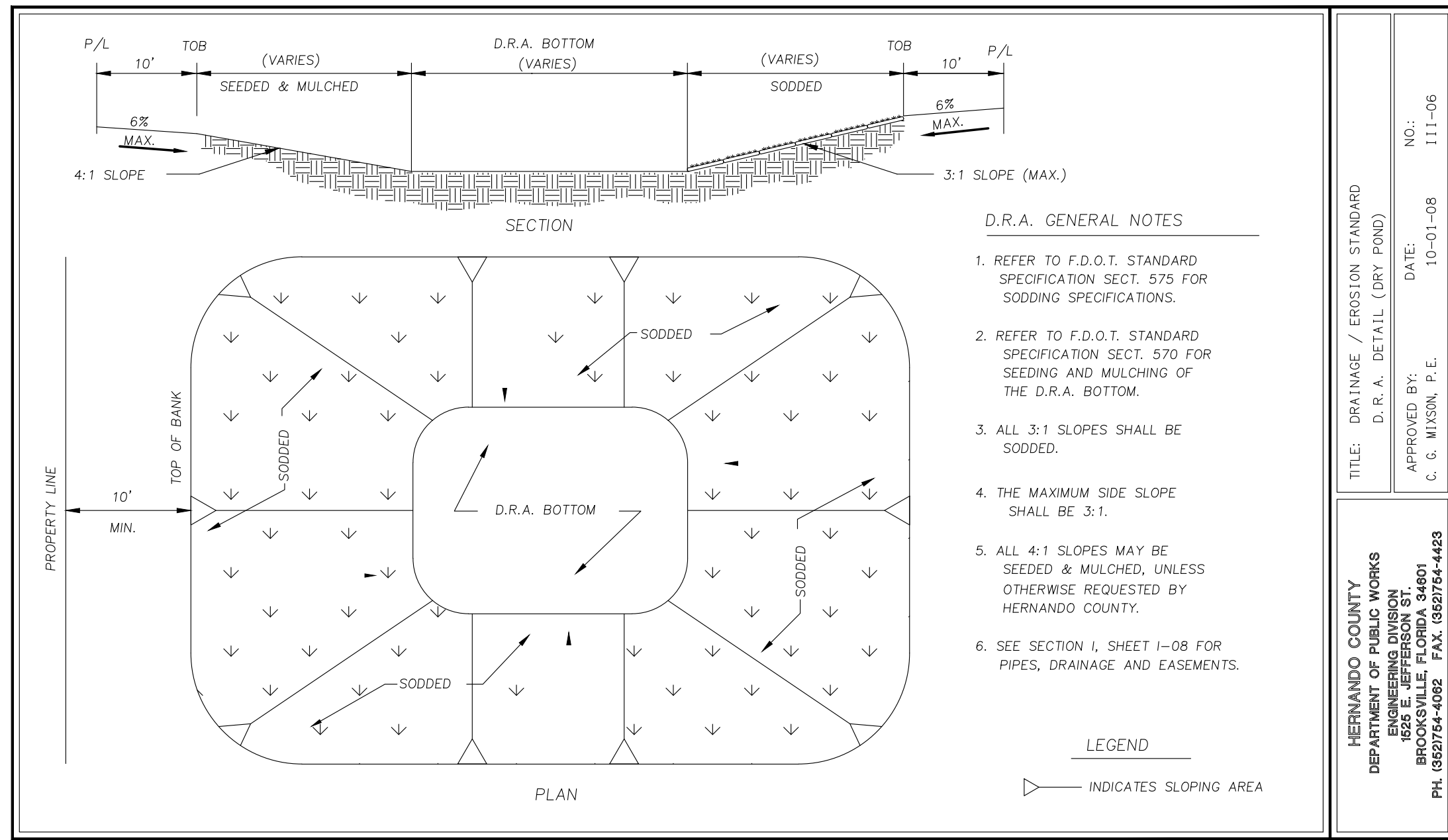

TITLE: DRAINAGE / EROSION STANDARD
 D.R.A. DETAIL (DRY POND)
 NO: 111-06
 DATE: 10-01-08
 APPROVED BY: C. G. MIXSON, P.E.
 HERNANDO COUNTY DEPARTMENT OF PUBLIC WORKS
 ENGINEERING DIVISION
 1822 E. JEFFERSON ST.
 BROOKSVILLE, FLORIDA 34801
 PH. (352)754-4082 FAX. (352)754-4423

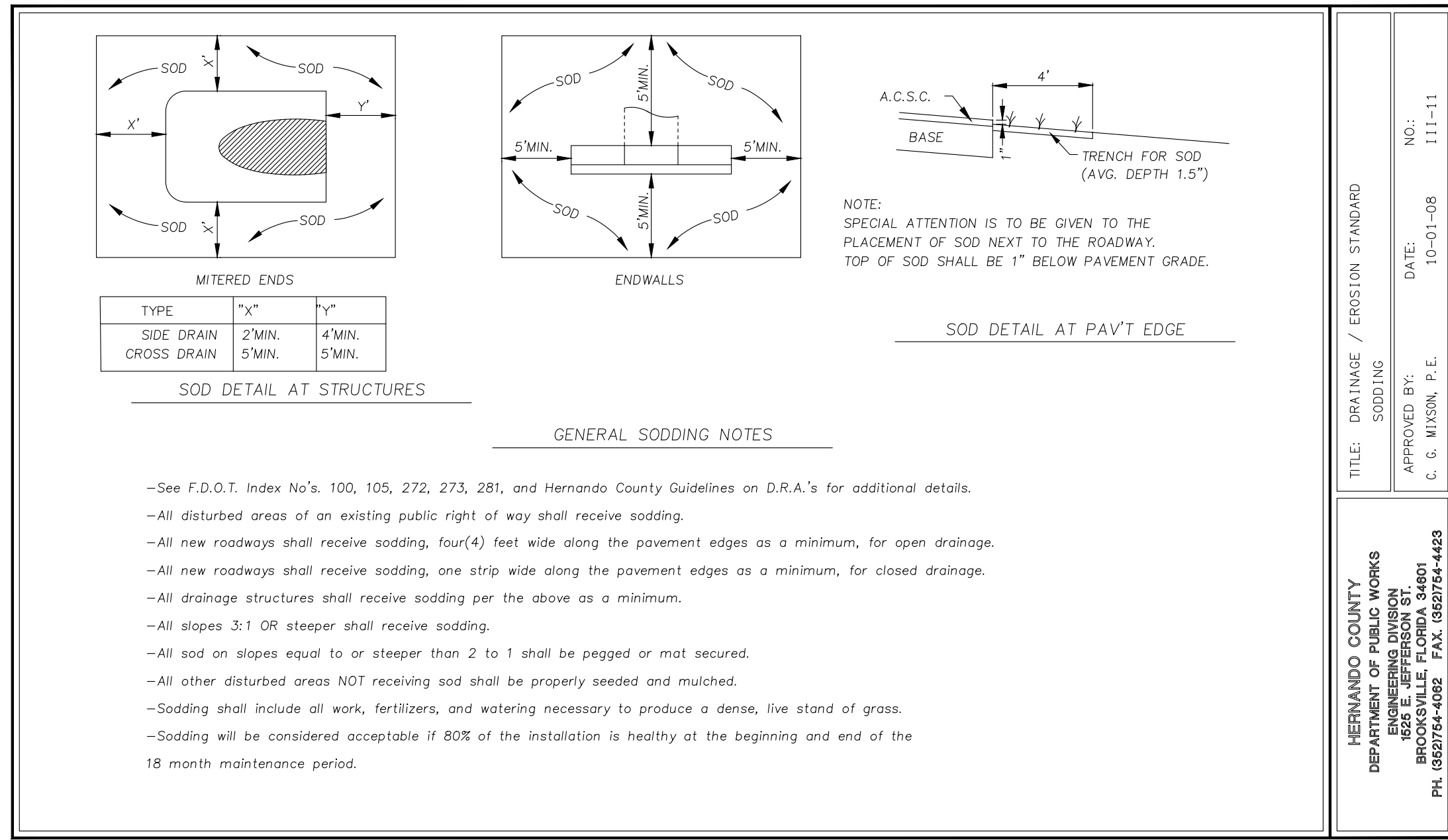

TITLE: DRAINAGE / EROSION STANDARD
 SODDING
 NO: 111-11
 DATE: 10-01-08
 APPROVED BY: C. G. MIXSON, P.E.
 HERNANDO COUNTY DEPARTMENT OF PUBLIC WORKS
 ENGINEERING DIVISION
 1822 E. JEFFERSON ST.
 BROOKSVILLE, FLORIDA 34801
 PH. (352)754-4082 FAX. (352)754-4423

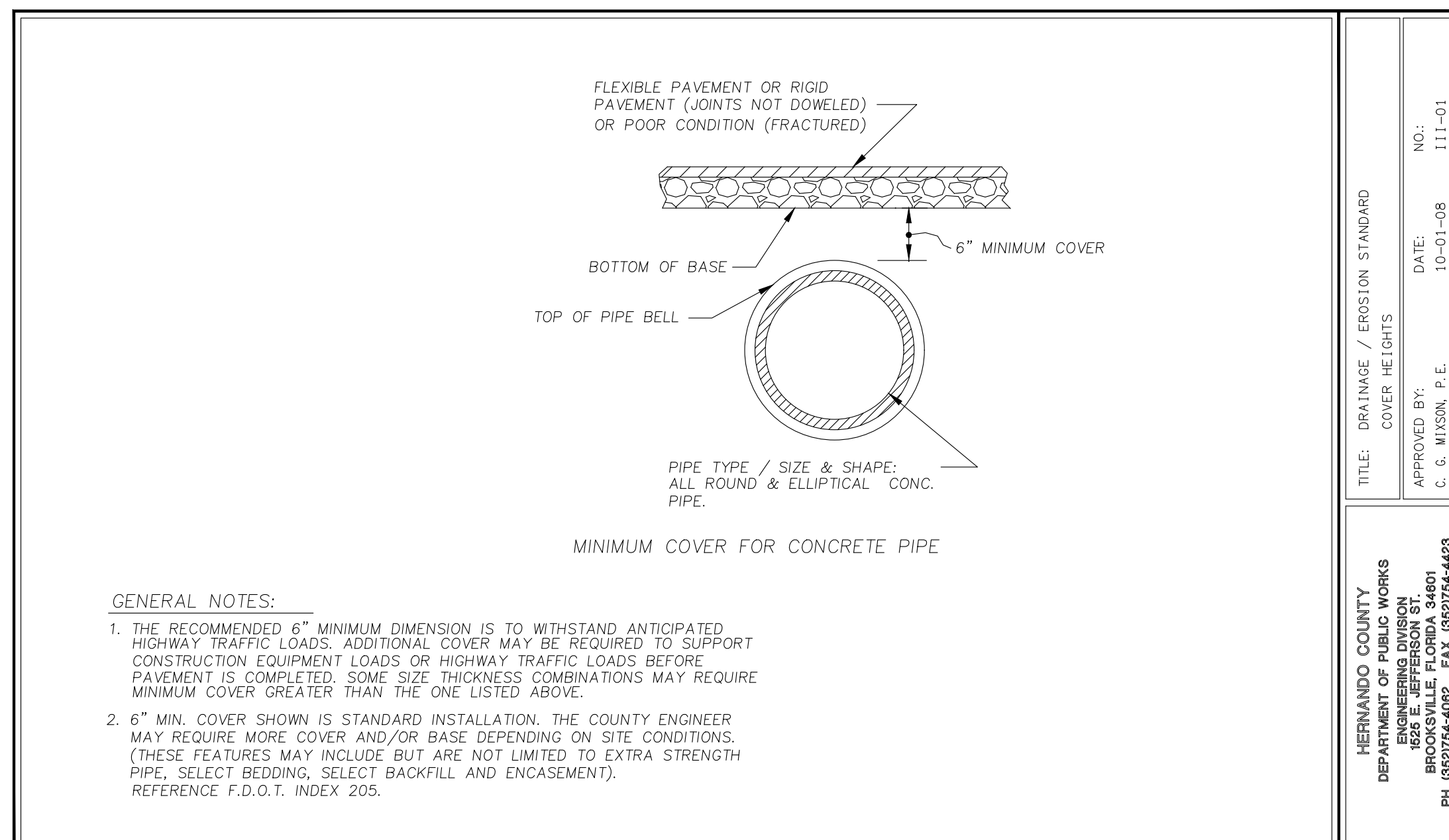

TITLE: DRAINAGE / EROSION STANDARD
 COVER HEIGHTS
 NO: 111-01
 DATE: 10-01-08
 APPROVED BY: C. G. MIXSON, P.E.
 HERNANDO COUNTY DEPARTMENT OF PUBLIC WORKS
 ENGINEERING DIVISION
 1822 E. JEFFERSON ST.
 BROOKSVILLE, FLORIDA 34801
 PH. (352)754-4082 FAX. (352)754-4423

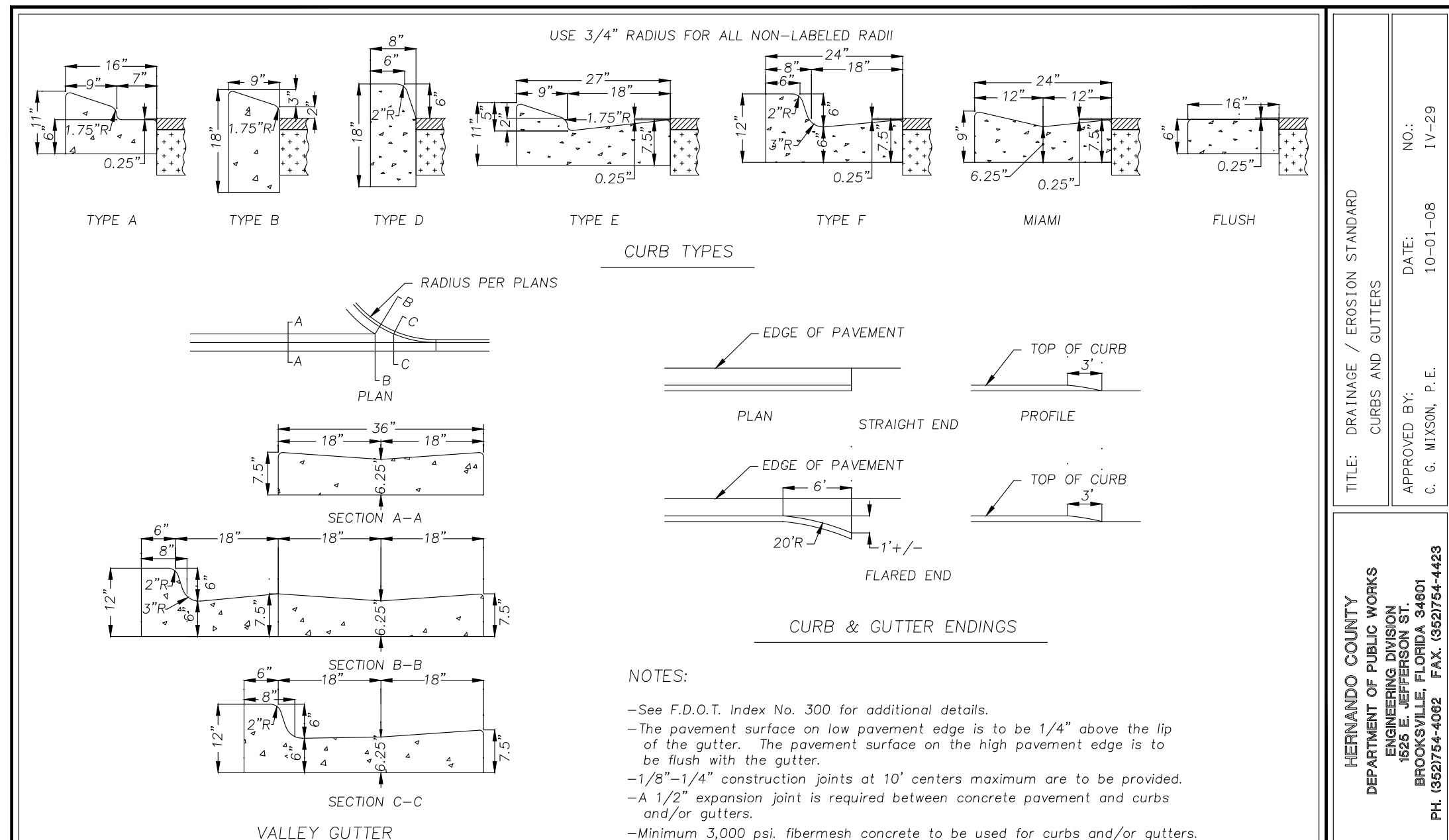

TITLE: DRAINAGE / EROSION STANDARD
 CURBS AND GUTTERS
 NO: 11-29
 DATE: 10-01-08
 APPROVED BY: C. G. MIXSON, P.E.
 HERNANDO COUNTY DEPARTMENT OF PUBLIC WORKS
 ENGINEERING DIVISION
 1822 E. JEFFERSON ST.
 BROOKSVILLE, FLORIDA 34801
 PH. (352)754-4082 FAX. (352)754-4423

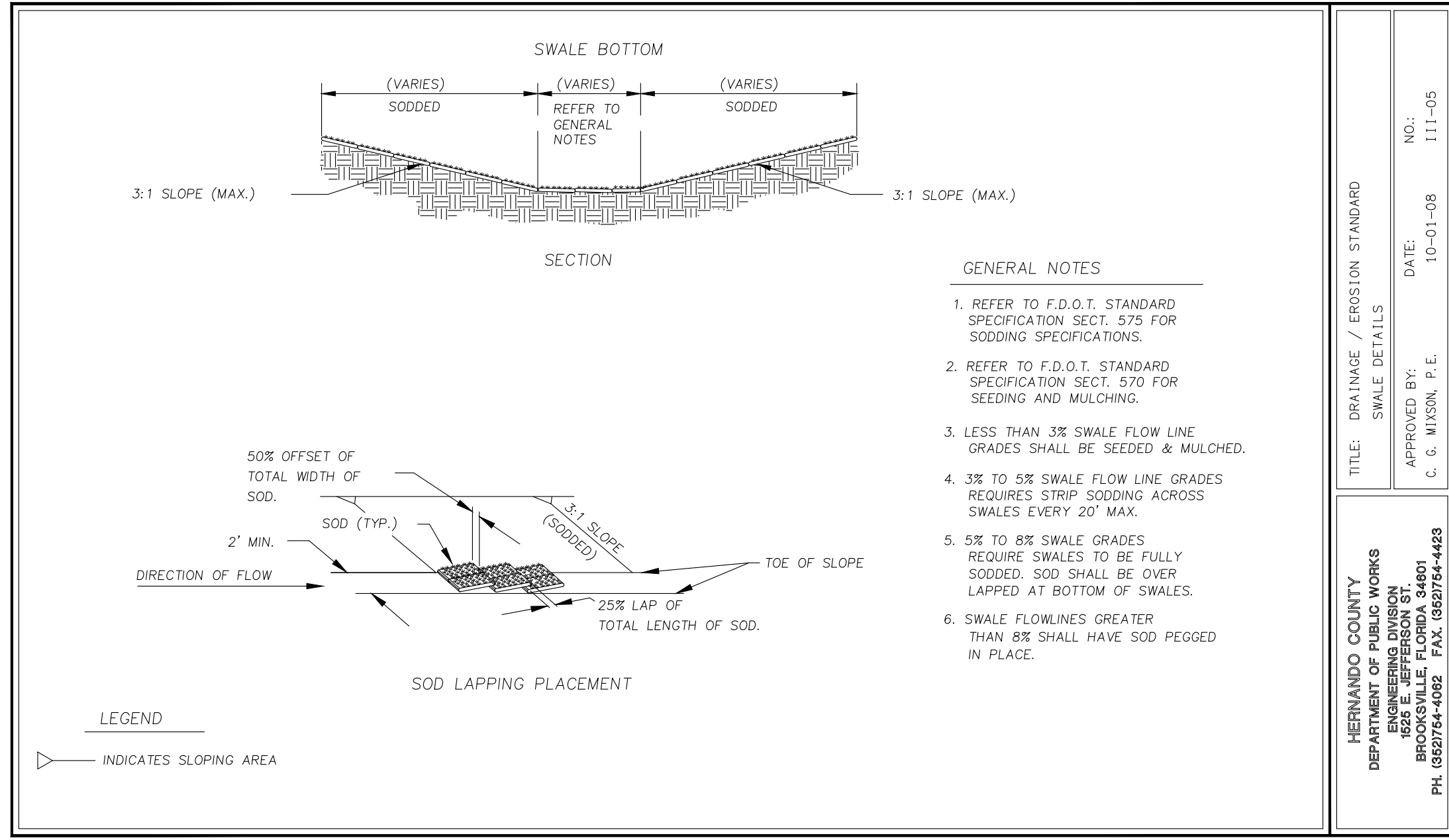

TITLE: DRAINAGE / EROSION STANDARD
 SWALE DETAILS
 NO: 111-05
 DATE: 10-01-08
 APPROVED BY: C. G. MIXSON, P.E.
 HERNANDO COUNTY DEPARTMENT OF PUBLIC WORKS
 ENGINEERING DIVISION
 1822 E. JEFFERSON ST.
 BROOKSVILLE, FLORIDA 34801
 PH. (352)754-4082 FAX. (352)754-4423

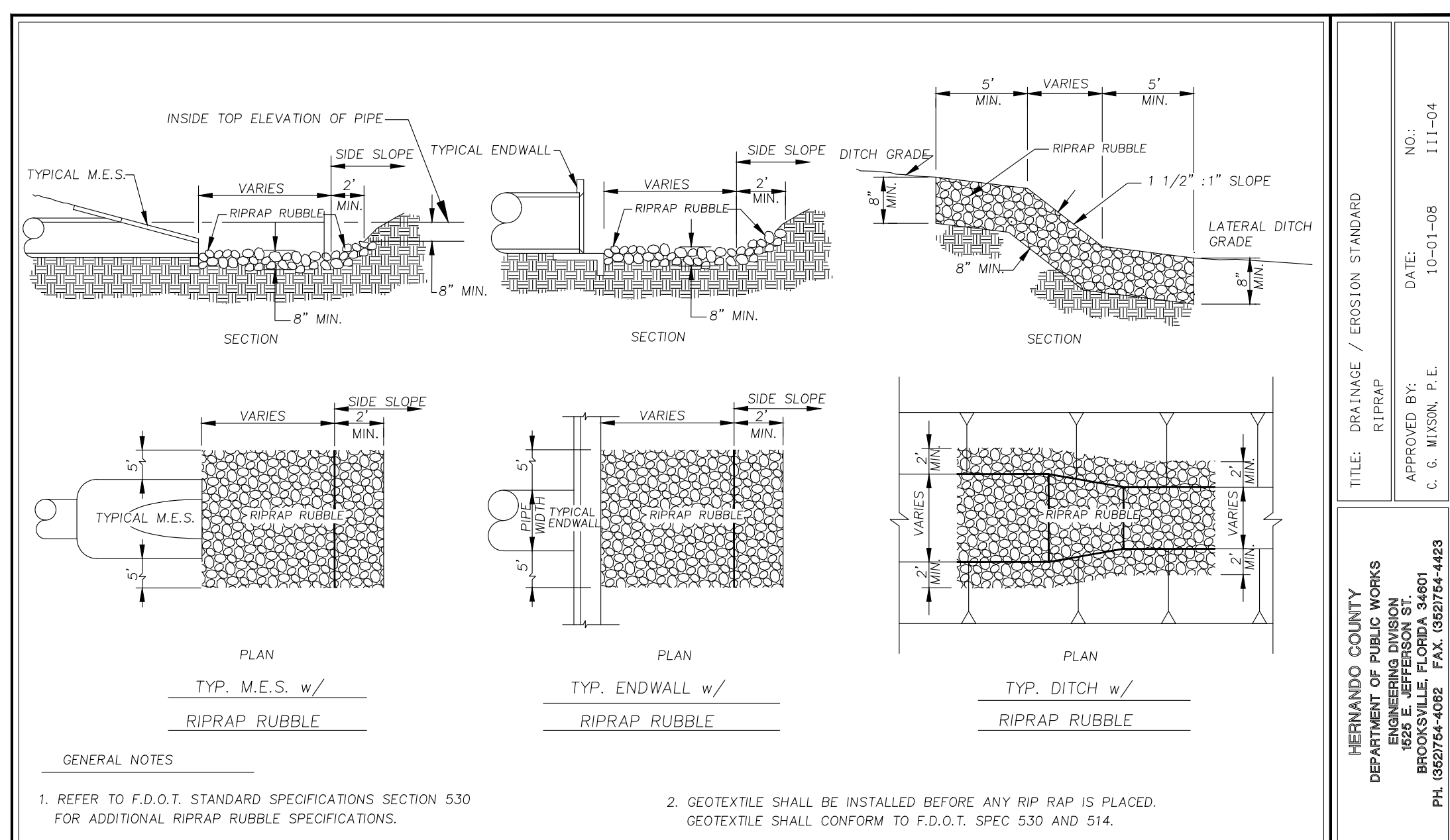

TITLE: DRAINAGE / EROSION STANDARD
 RIPRAP
 NO: 111-04
 DATE: 10-01-08
 APPROVED BY: C. G. MIXSON, P.E.
 HERNANDO COUNTY DEPARTMENT OF PUBLIC WORKS
 ENGINEERING DIVISION
 1822 E. JEFFERSON ST.
 BROOKSVILLE, FLORIDA 34801
 PH. (352)754-4082 FAX. (352)754-4423

DRAINAGE AND PAVING DETAILS 2

DR DENNIS WILFONG CENTER FOR SUCCESS

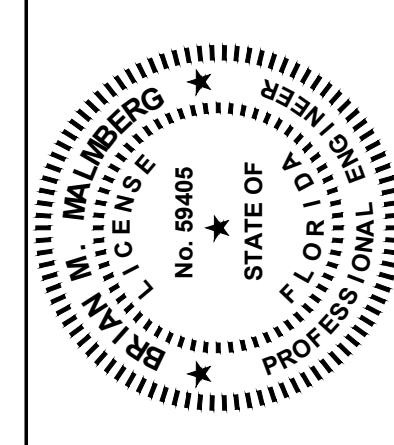

Coastal
 Engineering
 Surveying
 Environmental
 Transportation
 engineering associates, inc.
 966 Candlelight Boulevard - Brooksville - Florida 34801
 (352) 796-9423 - Fax (352) 799-8359
 EB-0000142

REUSE OF DOCUMENT

THIS DOCUMENT COMPRISED OF THE INFORMATION IS THE PROPERTY OF A.S. AN INSTRUMENT OF PROFESSIONAL SERVICE, IS THE PROPERTY OF COASTAL ENGINEERING ASSOCIATES, INC. AND IS NOT TO BE USED, IN WHOLE OR IN PART FOR ANY PROJECT WITHOUT THE WRITTEN AUTHORIZATION OF COASTAL ENGINEERING ASSOCIATES, INC.

DRAWING INVALID UNLESS SIGNED, DATED & SEALED BY REGISTERED PROFESSIONAL

DATE	REV. BY/REV. NO.	BID SET	REVISION
09/13/22	LEE 1	1	ADDRESS RCID COMMENTS ADJUST UTIL/STORM
10-13-22	LEE 2	2	ADDRESS RCID COMMENTS; ADD ALT BID SIDEWALK
1-24-23	LEE 3	3	

SHEET C-17

21115

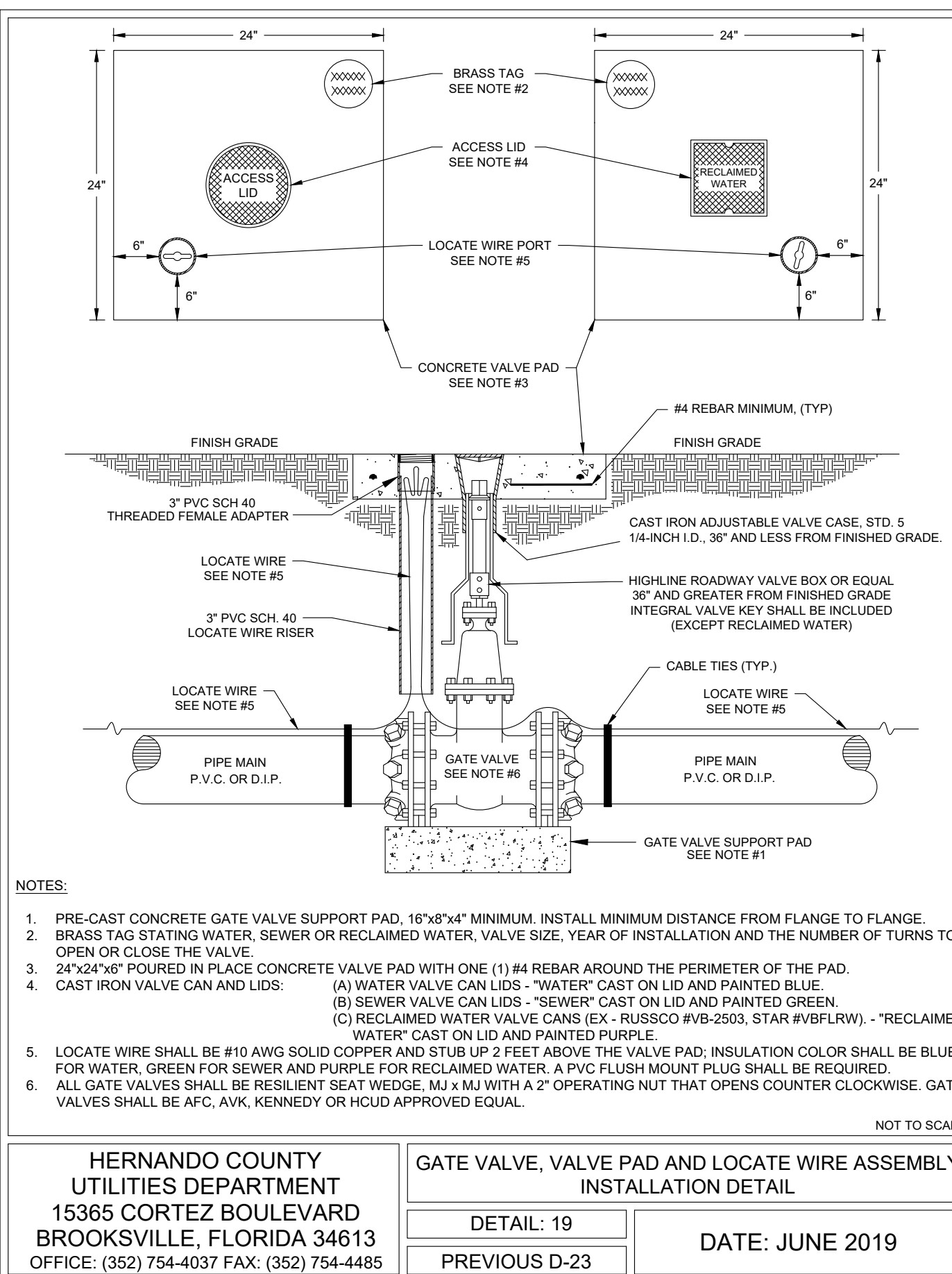
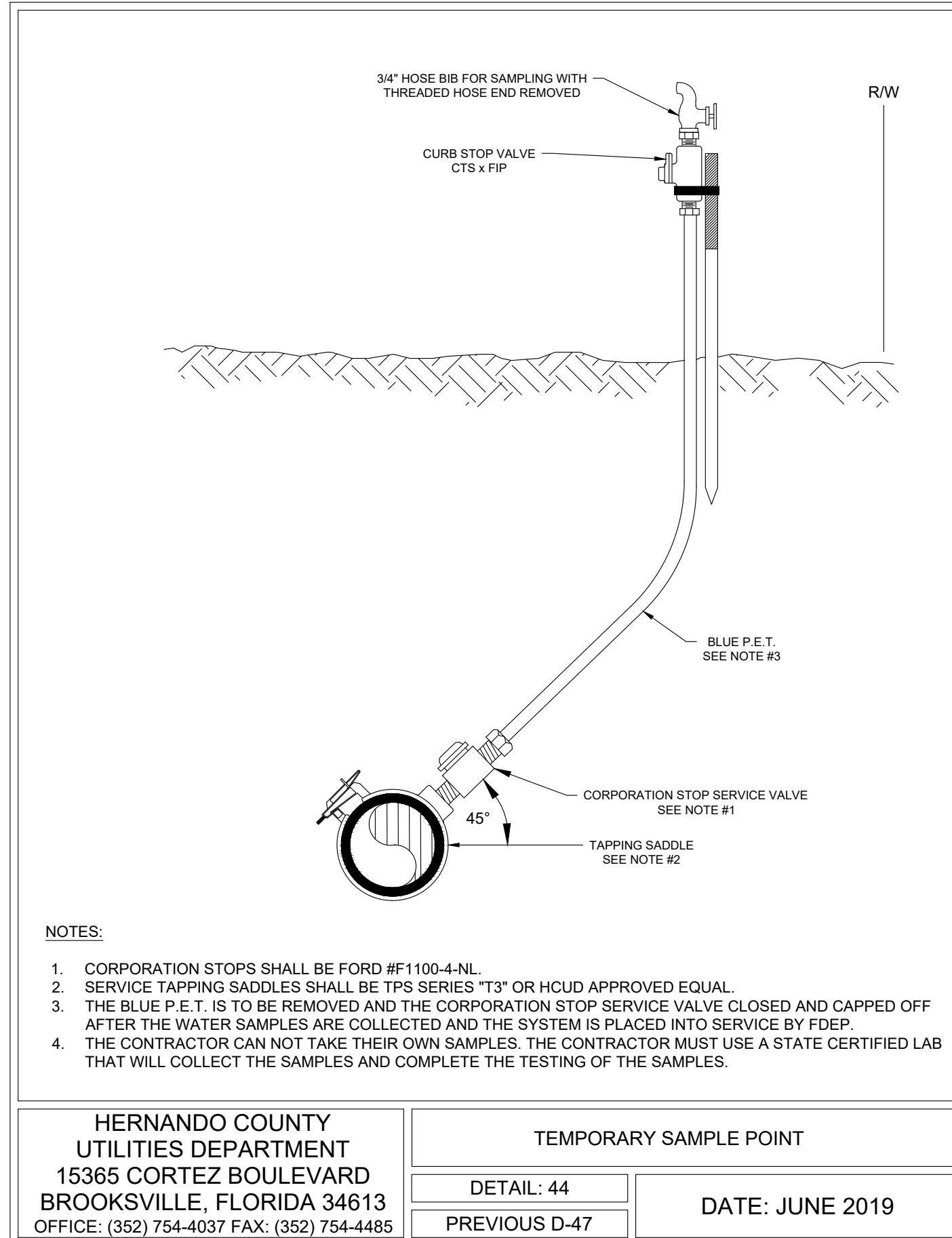
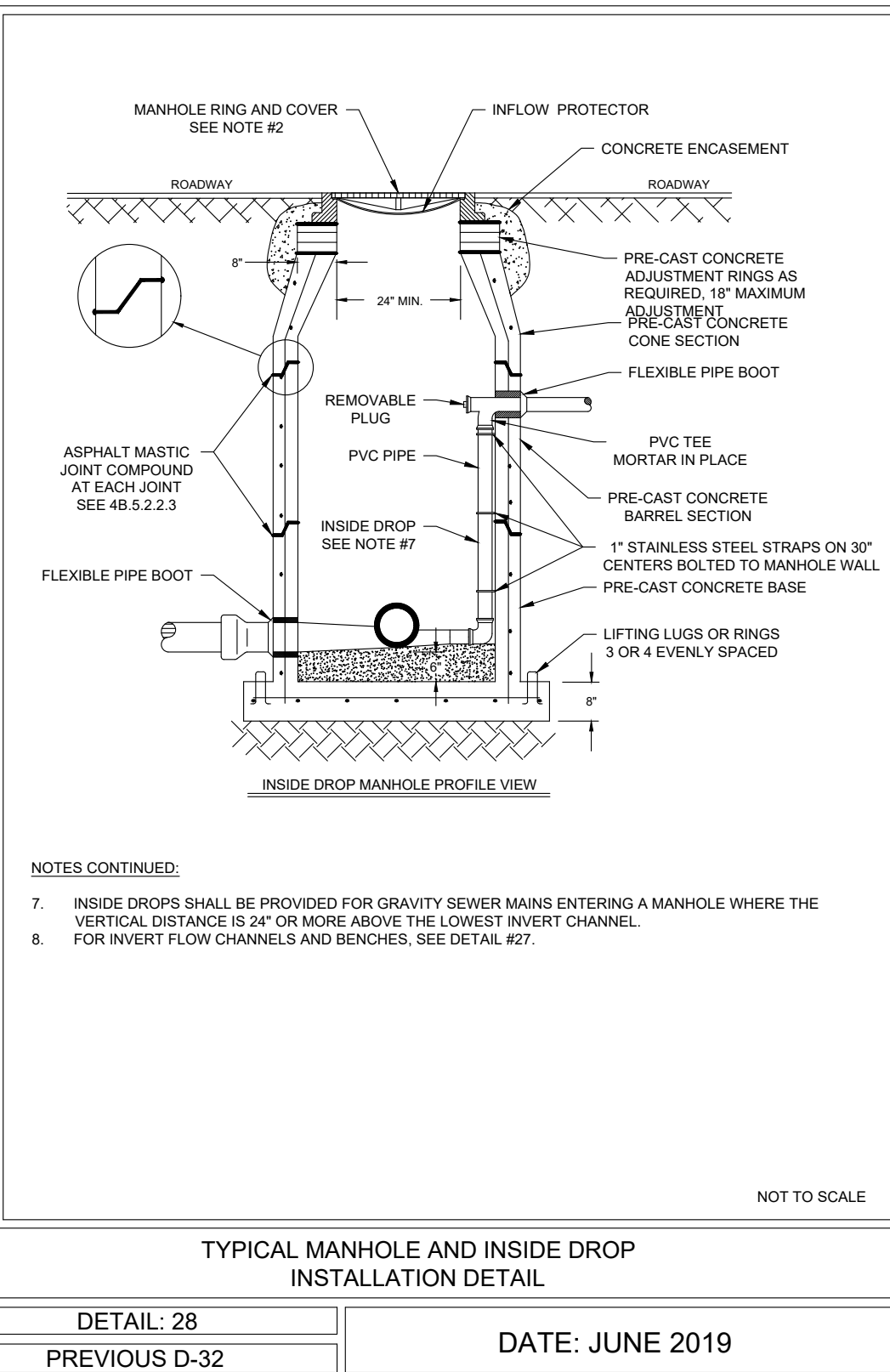
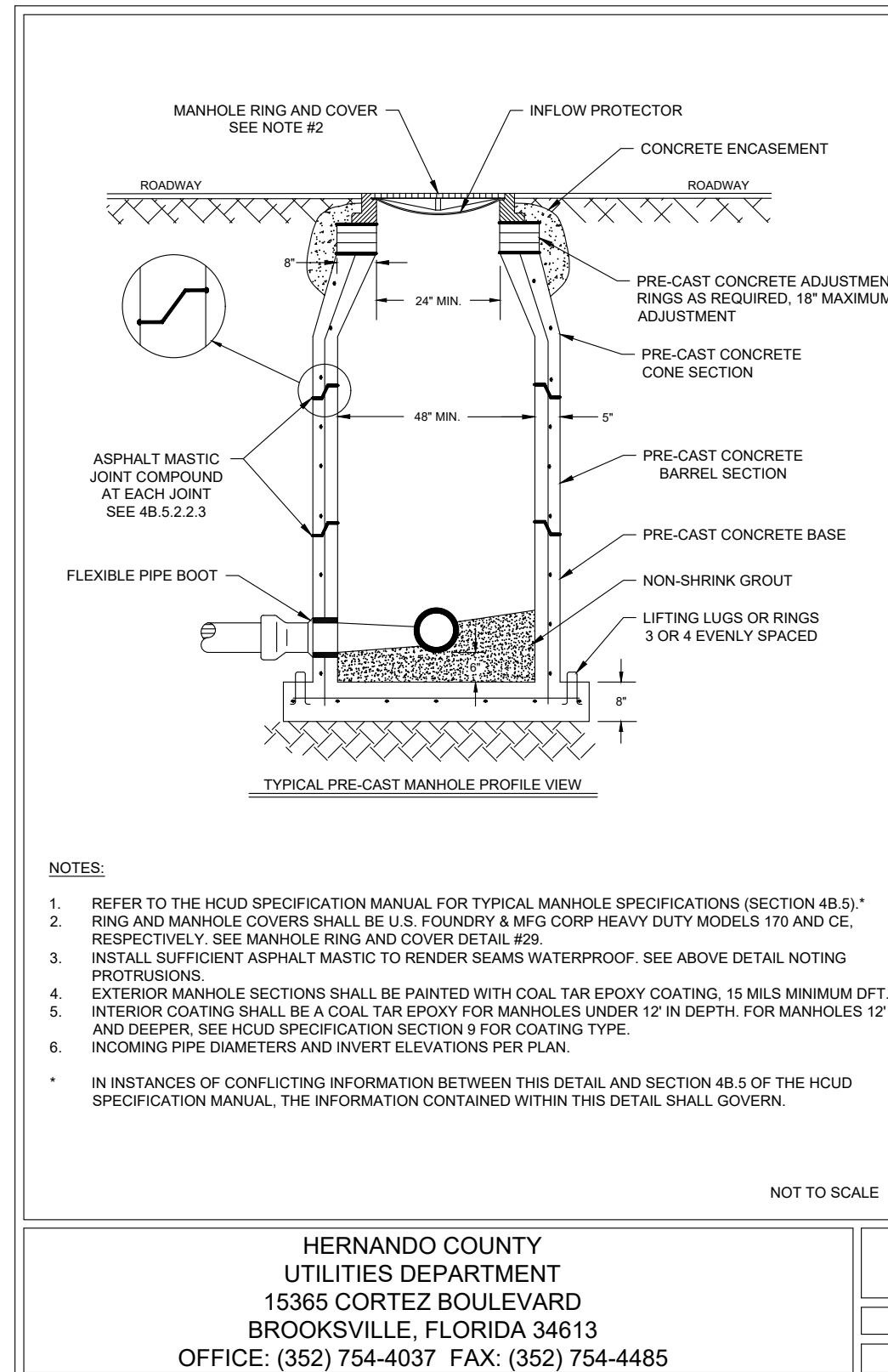
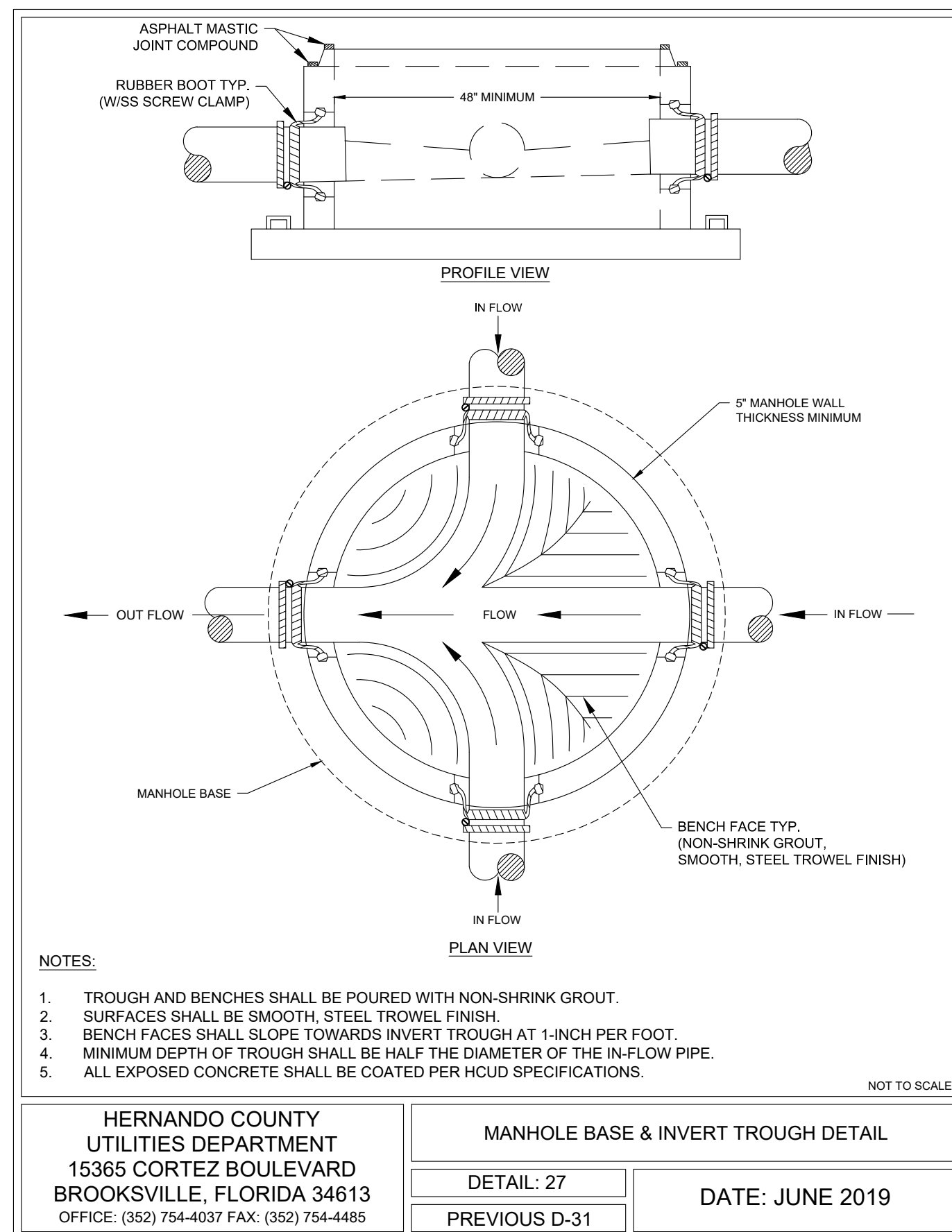

GRAVITY SEWER LINE TESTING LOW PRESSURE AIR TEST TABLE

PIPE LENGTH (IN FEET)	PIPE DIAMETER (IN INCHES)															
	4"	6"	8"	10"	12"	15"	18"	21"	24"	25"	30"	36"	42"	48"	54"	60"
25	0.04	0.10	0.18	0.28	0.40	1.02	1.27	2.01	2.38							
50	0.09	0.20	0.35	0.55	1.19	2.04	2.58	4.03	5.17							
75	0.13	0.30	0.53	1.23	1.59	3.06	4.27	6.04	7.55							
100	0.18	0.40	1.10	1.50	2.38	4.08	5.56	8.05	10.34							
125	0.22	0.50	1.28	2.18	3.18	5.09	7.26	9.55	11.20							
150	0.26	0.59	1.46	2.45	3.58	6.11	8.30									
175	0.31	1.09	2.03	3.13	4.37	7.05										
200	0.35	1.19	2.21	3.40	5.17											
225	0.40	1.29	2.38	4.08	5.40			10.25	13.36							
250	0.44	1.39	2.56	4.35				8.31	11.35	15.07						
275	0.48	1.49	3.14	4.43				9.21	12.44	16.38						
300	0.53	1.59	3.31	4.48				10.12	13.53	18.09						
350	1.02	2.19	3.47			8.16	11.54	16.12	21.10							
400	1.28	2.38			6.03	9.27	13.36	18.31	24.12							

HERNANDO COUNTY UTILITIES DEPARTMENT
15365 CORTEZ BOULEVARD
BROOKSVILLE, FLORIDA 34613
OFFICE: (352) 754-4037 FAX: (352) 754-4485

GRAVITY SEWER LINE TESTING LOW PRESSURE AIR TEST TABLE
DETAIL: 24
PREVIOUS D-27
DATE: JUNE 2019

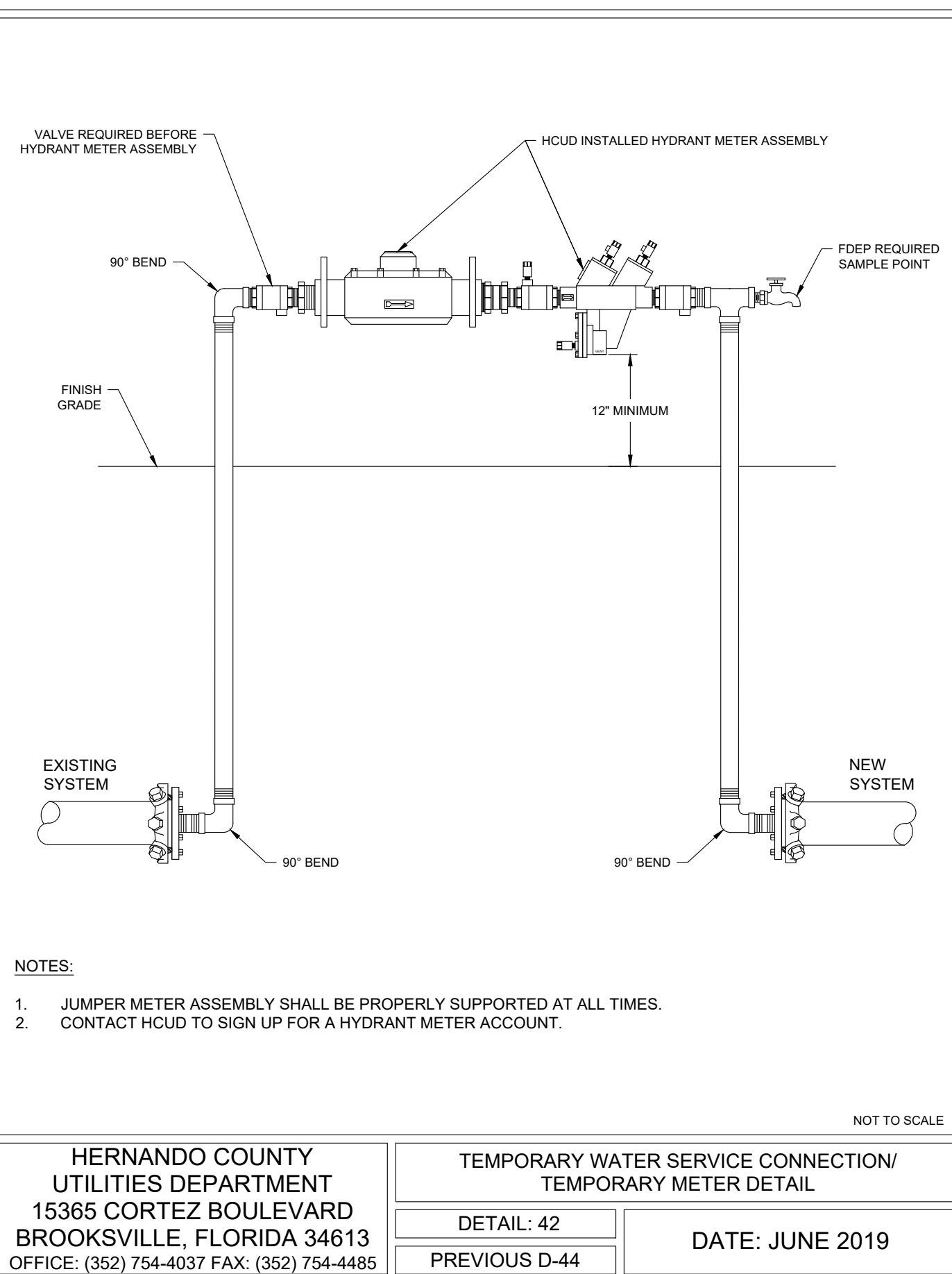
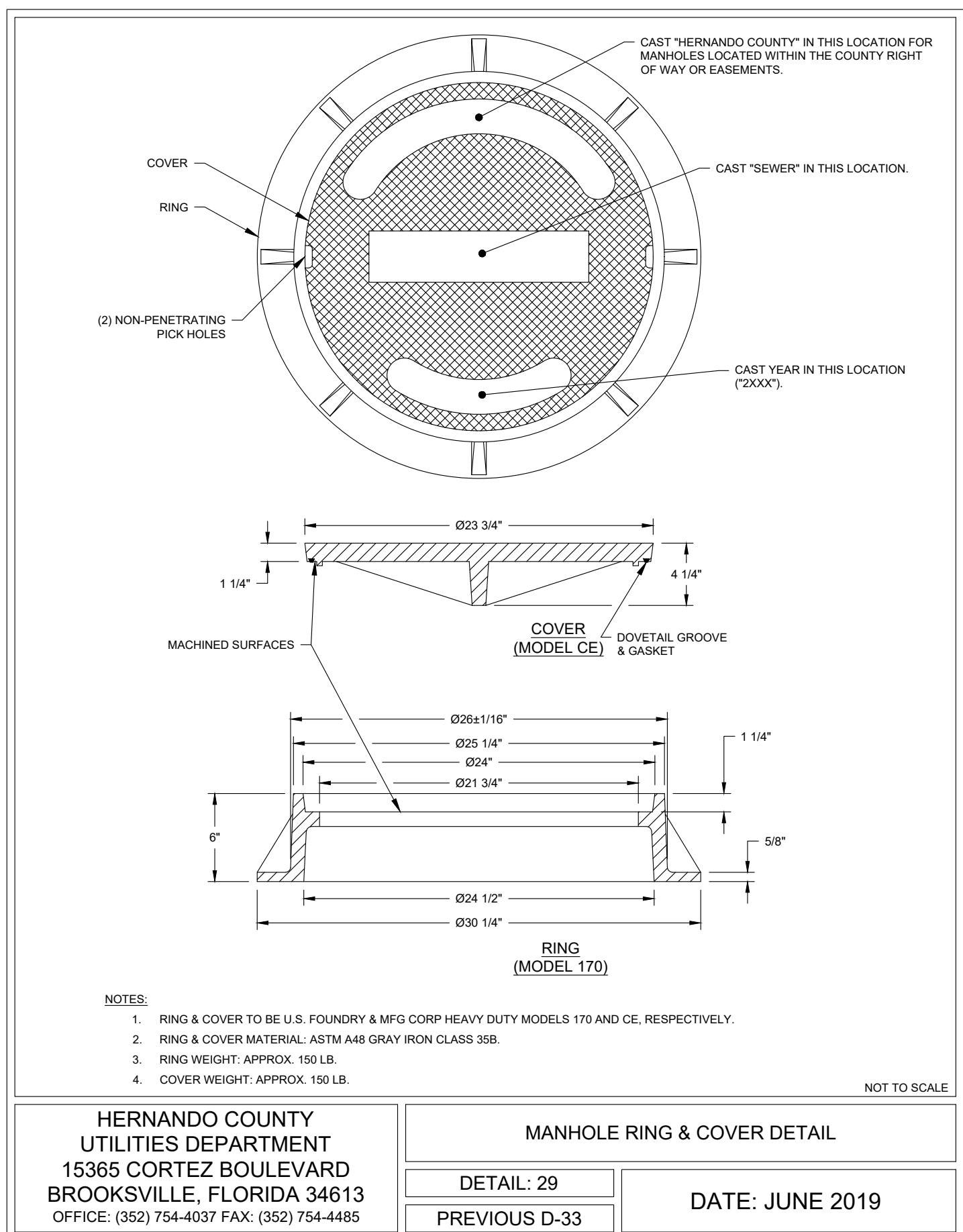

UTILITY DETAILS 1

DR DENNIS WILFONG CENTER FOR SUCCESS

Professional Engineer
No. 89405
STATE OF FLORIDA
Professional Seal

Engineering
Surveying
Environmental
Transportation
Construction Management
Coastal
engineering associates, inc.
966 Candlelight Boulevard - Brooksville, Florida 34601
(352) 796-9423 Fax: (352) 796-8359
EE-000142

REUSE OF DOCUMENT
THIS DOCUMENT, COMPRISED OF THE DRAWINGS AND ALL ATTACHED SCHEDULES, IS THE PROPERTY OF COASTAL ENGINEERING ASSOCIATES, INC. AND IS NOT TO BE REPRODUCED, COPIED, OR TRANSMITTED IN ANY FORM OR BY ANY MEANS, WITHOUT THE WRITTEN PERMISSION OF COASTAL ENGINEERING ASSOCIATES, INC. DRAWINGS, IN ANY MANNER, SHALL BE SEALED BY REGISTERED PROFESSIONAL ENGINEERS.

DATE	REV. BY/REV. NO.	DESCRIPTION
09/13/22	LEE	1 BID SET
10-13-22	LEE	2 ADDRESS HCUD COMMENTS ADJUST UTIL/STORM LOCATIONS ON SH DRIVE
1-24-23	LEE	3 HCUD COMMENTS, ADD ALT BID SIDEWALK

WHEN PRINTED TO SCALE, DRAWING SIZE SHALL BE 22" X 34"

SHEET C-18

JOB No. 21115

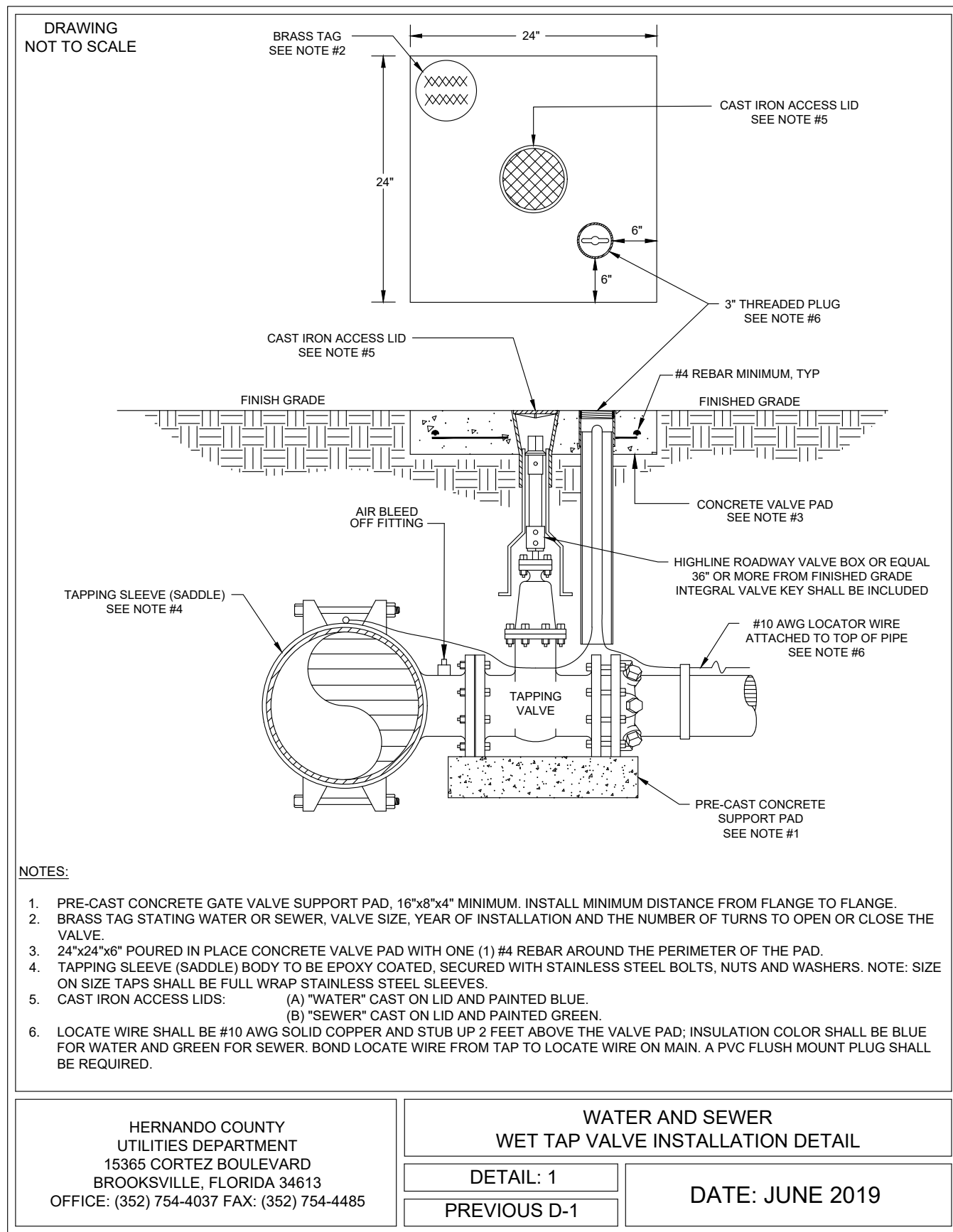

LOCATION OF PUBLIC WATER SYSTEM MAINS IN ACCORDANCE WITH F.A.C. RULE 62-555.314

OTHER PIPE	HORIZONTAL SEPARATION	CROSSINGS (1)	JOINT SPACING AT CROSSINGS (FULL JOINT CENTERED)
STORM SEWER, STORM WATER FORCE MAIN, RECLAIMED WATER (2)	WATER MAIN 3 FEET MINIMUM	WATER MAIN 12 INCHES MINIMUM, EXCEPT FOR STORM SEWER, THEN 6 INCHES IS MINIMUM, 12 INCHES PREFERRED	WATER MAIN ALTERNATE 9 FEET MINIMUM
VACUUM SANITARY SEWER	WATER MAIN 10 FEET PREFERRED 3 FEET MINIMUM	WATER MAIN 12 INCHES PREFERRED 6 INCHES MINIMUM	WATER MAIN ALTERNATE 9 FEET MINIMUM
GRAVITY OR PRESSURE, SANITARY SEWER, SANITARY SEWER FORCE MAIN, RECLAIMED WATER (4)	WATER MAIN 10 FEET PREFERRED 6 FEET MINIMUM (3)	WATER MAIN 12 INCHES MINIMUM, EXCEPT FOR GRAVITY SEWER, THEN 6 INCHES IS MINIMUM, 12 INCHES PREFERRED	WATER MAIN ALTERNATE 6 FEET MINIMUM
ON-SITE SEWAGE TREATMENT AND DISPOSAL SYSTEM	10 FEET MINIMUM	----	----

NOTES:
 (1) WATER MAIN SHOULD CROSS ABOVE OTHER PIPE. WHEN WATER MAIN MUST BE BELOW OTHER PIPE, THE MINIMUM SEPARATION IS 12 INCHES.
 (2) RECLAIMED WATER REGULATED UNDER PART III OF CHAPTER 62-610, F.A.C.
 (3) 3 FEET FOR GRAVITY SANITARY SEWER WHERE THE BOTTOM OF THE WATER MAIN IS LAID AT LEAST 6 INCHES ABOVE THE TOP OF THE GRAVITY SANITARY SEWER.
 (4) RECLAIMED WATER NOT REGULATED UNDER PART III OF CHAPTER 62-610, F.A.C.

DISCLAIMER - THIS DOCUMENT IS PROVIDED FOR YOUR CONVENIENCE ONLY. PLEASE REFER TO F.A.C. RULE 62-555.314 FOR ADDITIONAL CONSTRUCTION REQUIREMENTS.

HERNANDO COUNTY UTILITIES DEPARTMENT
15365 CORTEZ BOULEVARD
BROOKSVILLE, FLORIDA 34613
OFFICE: (352) 754-4037 FAX: (352) 754-4485

FDEP PIPELINE SEPARATION DETAIL
DETAIL: 14
PREVIOUS D-17
DATE: JUNE 2019

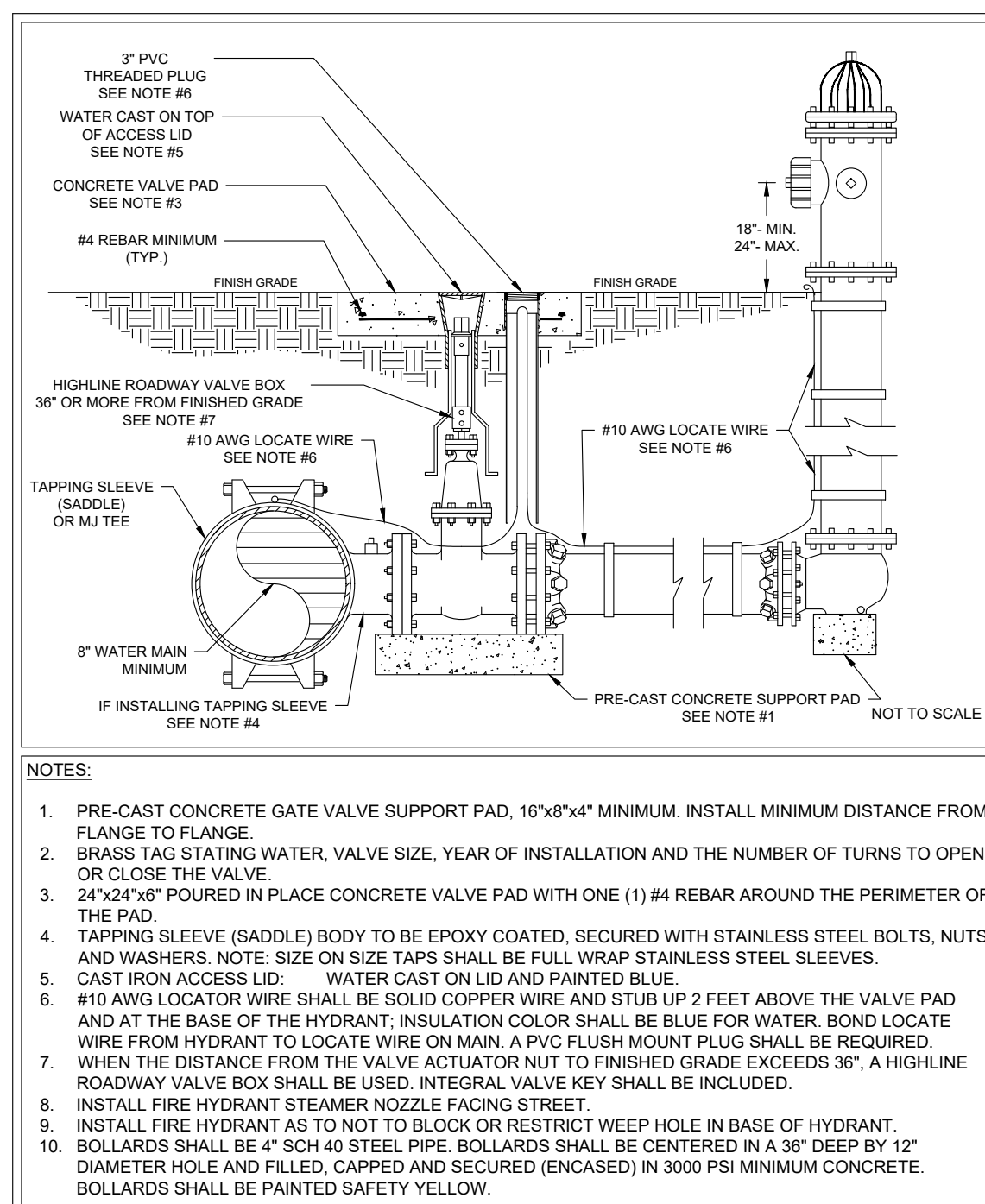
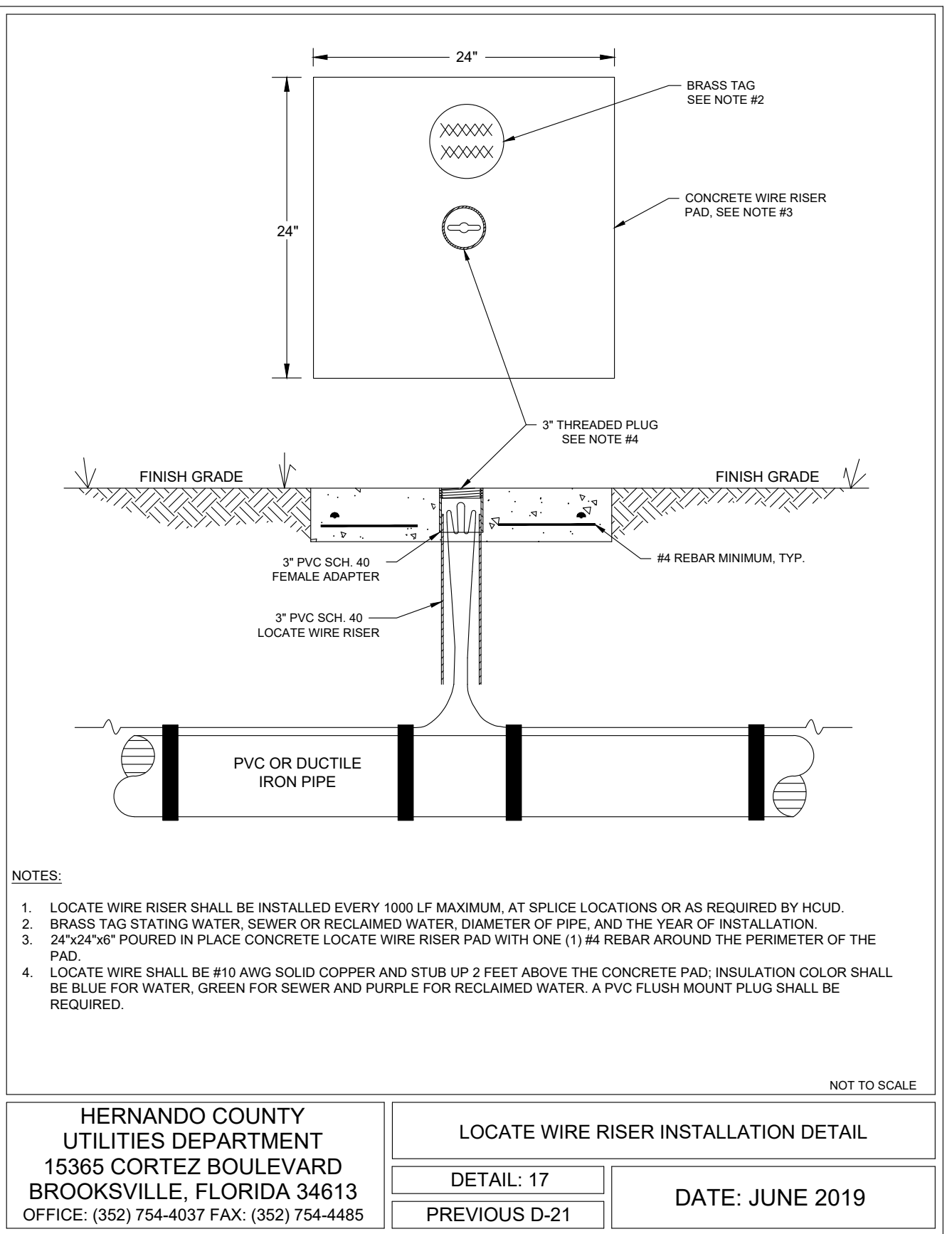

DUCTILE IRON PIPE RESTRAINED JOINTS FOR HORIZONTAL FITTINGS

PIPE SIZE (INCHES)	4	6	8	10	12	14	16	18	20	24
1 1/2" BEND	2(3)	3(4)	4(5)	5(6)	6(6)	6(7)	7(8)	8(9)	8(9)	9(11)
2 1/2" BEND	5(5)	6(7)	8(9)	9(11)	11(12)	12(14)	13(16)	15(17)	16(18)	18(21)
4 5" BEND	9(10)	12(14)	16(18)	19(22)	22(25)	25(28)	27(32)	30(35)	33(38)	37(43)
4 5" BEND	21(24)	29(33)	37(44)	44(52)	52(60)	59(68)	65(76)	72(83)	78(91)	90(104)
CAPPED END *	43(61)	59(85)	78(111)	93(132)	109(155)	124(177)	139(198)	153(218)	167(238)	194(277)
IN-LINE VALVE **	35(50)	49(71)	64(92)	77(111)	90(130)	103(148)	115(165)	128(182)	139(198)	160(230)

DUCTILE IRON PIPE RESTRAINED JOINTS FOR VERTICAL FITTINGS

PIPE SIZE (INCHES)	4	6	8	10	12	14	16	18	20	24
1 1/2" BEND	5(6)	6(9)	8(11)	10(13)	11(16)	13(18)	14(20)	15(22)	17(24)	20(28)
2 1/2" BEND	9(12)	12(17)	16(22)	19(27)	22(31)	25(36)	28(40)	31(44)	34(48)	39(56)
4 5" BEND	18(25)	25(35)	32(46)	39(55)	45(65)	52(73)	58(82)	64(91)	69(99)	81(115)
90° BEND	43(61)	59(85)	78(111)	93(132)	109(155)	124(177)	139(198)	153(218)	167(238)	194(277)

DUCTILE IRON PIPE TEE RESTRAINED JOINTS

SPRIG (MIN)	BRANCH (INCHES)									
	4	6	8	10	12	14	16	18	20	24
4	31(30)									
6	11(15)	38(54)								
8	0(0)	31(44)	56(79)							
10	0(0)	23(32)	50(71)	71(101)						
12	0(0)	15(21)	44(62)	66(94)	87(123)					
14	0(0)	6(9)	37(53)	61(87)	82(117)	101(144)				
16	0(0)	0(0)	31(44)	56(79)	78(111)	98(139)	116(160)			
18	0(0)	0(0)	24(34)	50(71)	73(105)	94(134)	113(161)	130(185)		
20	0(0)	0(0)	17(24)	45(63)	69(98)	90(128)	109(156)	127(181)	144(205)	
24	0(0)	0(0)	2(3)	33(46)	59(84)	81(116)	102(140)	121(172)	138(197)	171(244)

NOTES:
 1. THE PROGRAM "THRUST RESTRAINT DESIGN FOR DUCTILE IRON PIPE" ON THE DUCTILE IRON PIPE RESEARCH ASSOCIATION (DIPRA) WEB SITE WAS USED TO CALCULATE THE LENGTH OF RESTRAINED JOINTS. THE CALCULATIONS ARE BASED ON TYPE 3 LAYING CONDITIONS, SANDY/SILT SOIL DESIGNATION, 3.0 FEET MINIMUM COVERAGE AND 190 PSI OPERATING PRESSURE WITH A 1.5 TO 1 SAFETY FACTOR. THE LINEAR FEET SHOWN ARE MINIMUM REQUIREMENTS.
 2. THE NUMBER IN PARENTHESES REPRESENTS LINEAR FEET OF RESTRAINT FOR PVC PIPE AND POLY WRAPPED DUCTILE IRON PIPE.
 3. THE LINEAR FEET OF PIPE IS MEASURED FROM THE FITTING OR VALVE OUT TO THE AMOUNT SHOWN ON THE CHART. ANY BELL OR JOINT WITH THAT MEASUREMENT SHALL HAVE A BELL OR JOINT RESTRAINT INSTALLED.
 4. ALL BEND FITTINGS SHALL HAVE RESTRAINTS INSTALLED PER THE CHART IN BOTH DIRECTIONS.
 5. BRANCH SIDE OF TEE IS TO BE RESTRAINED PER THE CHART.
 * CAPPED ENDS ALSO INCLUDES VALVES INSTALLED AT THE END OF THE PIPE.
 ** IN-LINE VALVES SHALL BE RESTRAINED IN BOTH DIRECTIONS THE AMOUNT SHOWN ON CHART.

HERNANDO COUNTY UTILITIES DEPARTMENT
15365 CORTEZ BOULEVARD
BROOKSVILLE, FLORIDA 34613
OFFICE: (352) 754-4037 FAX: (352) 754-4485

PIPELINE JOINT RESTRAINT SPECIFICATION DETAIL
DETAIL: 12
PREVIOUS D-15
DATE: JUNE 2019

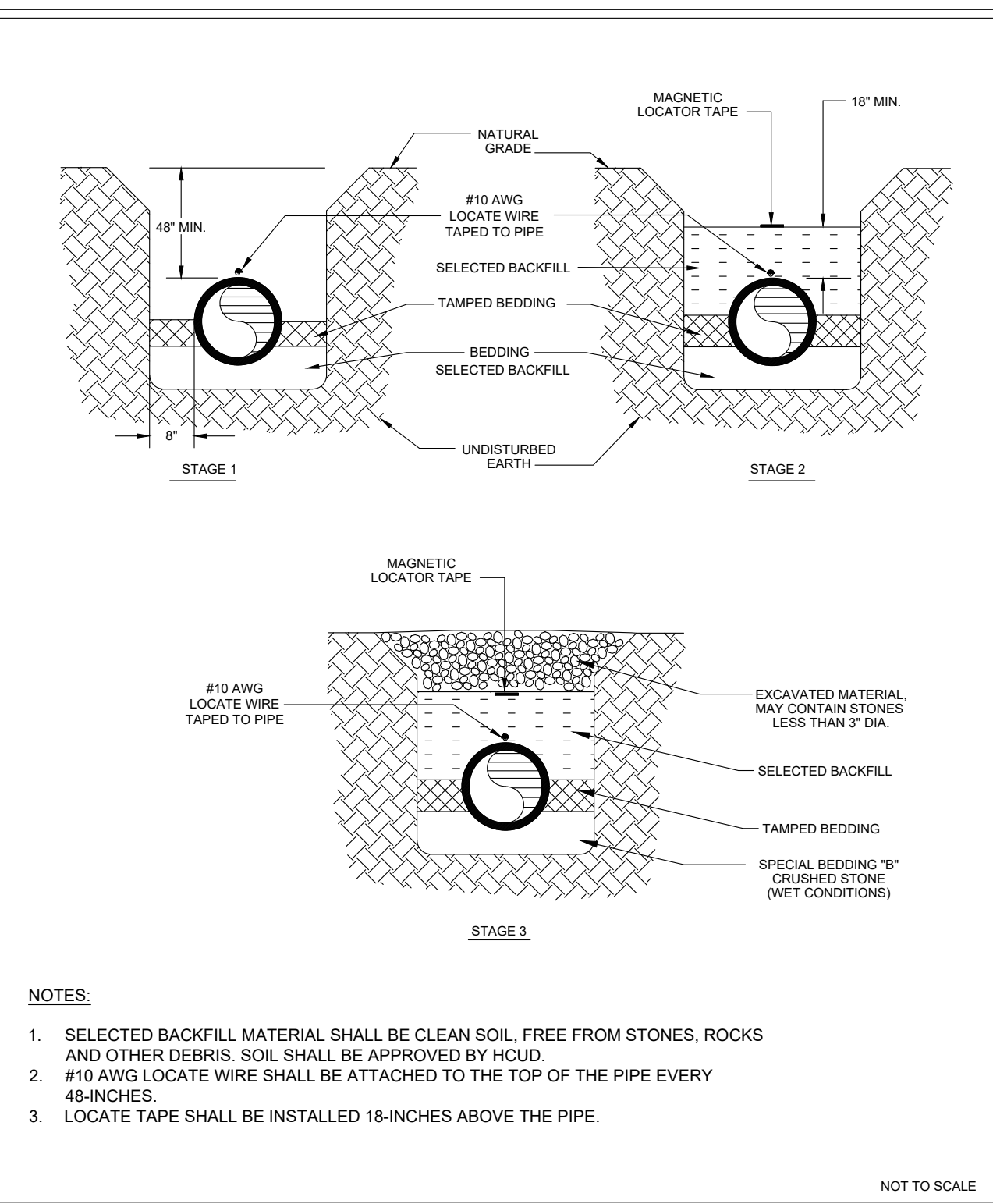
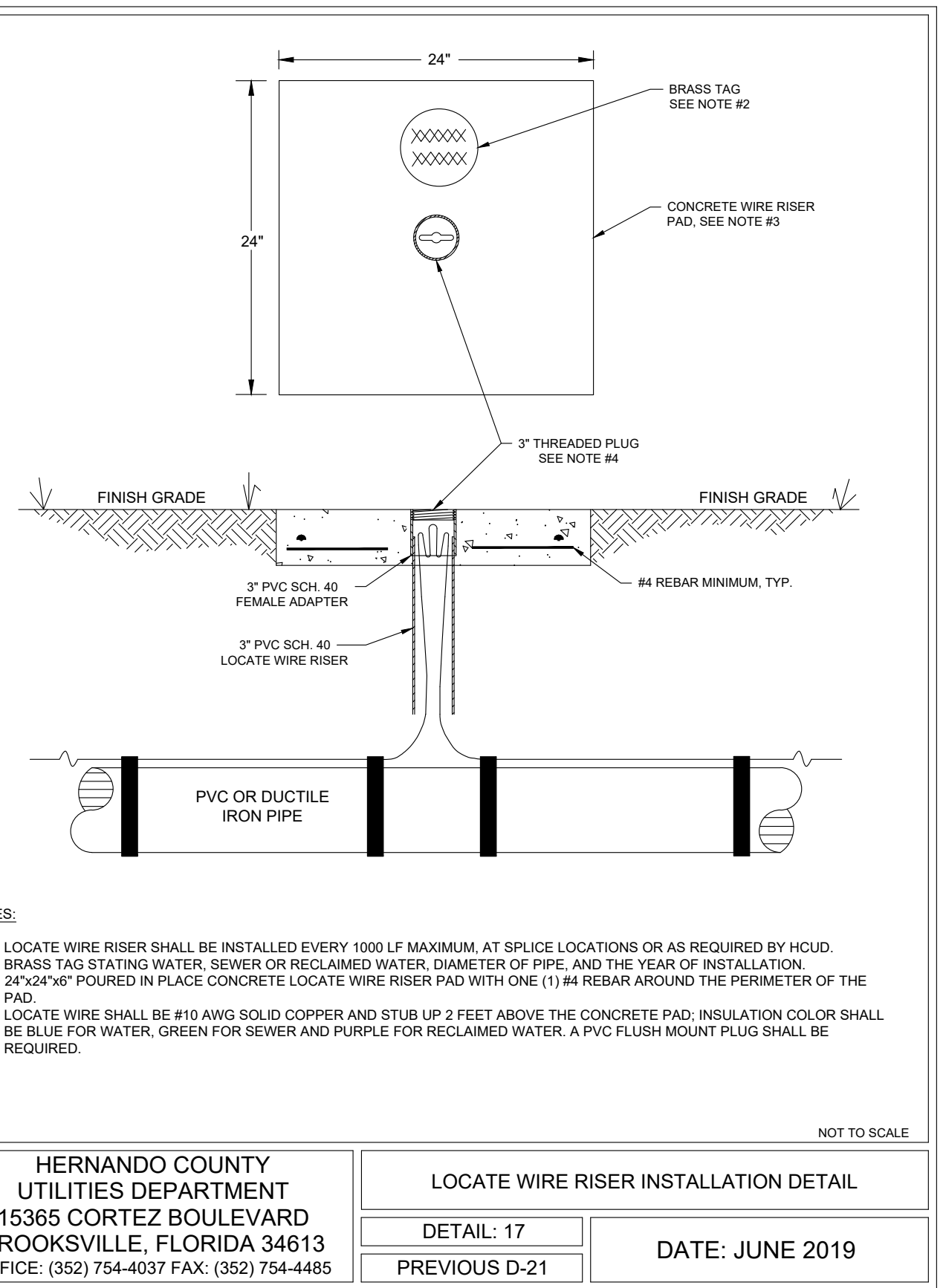
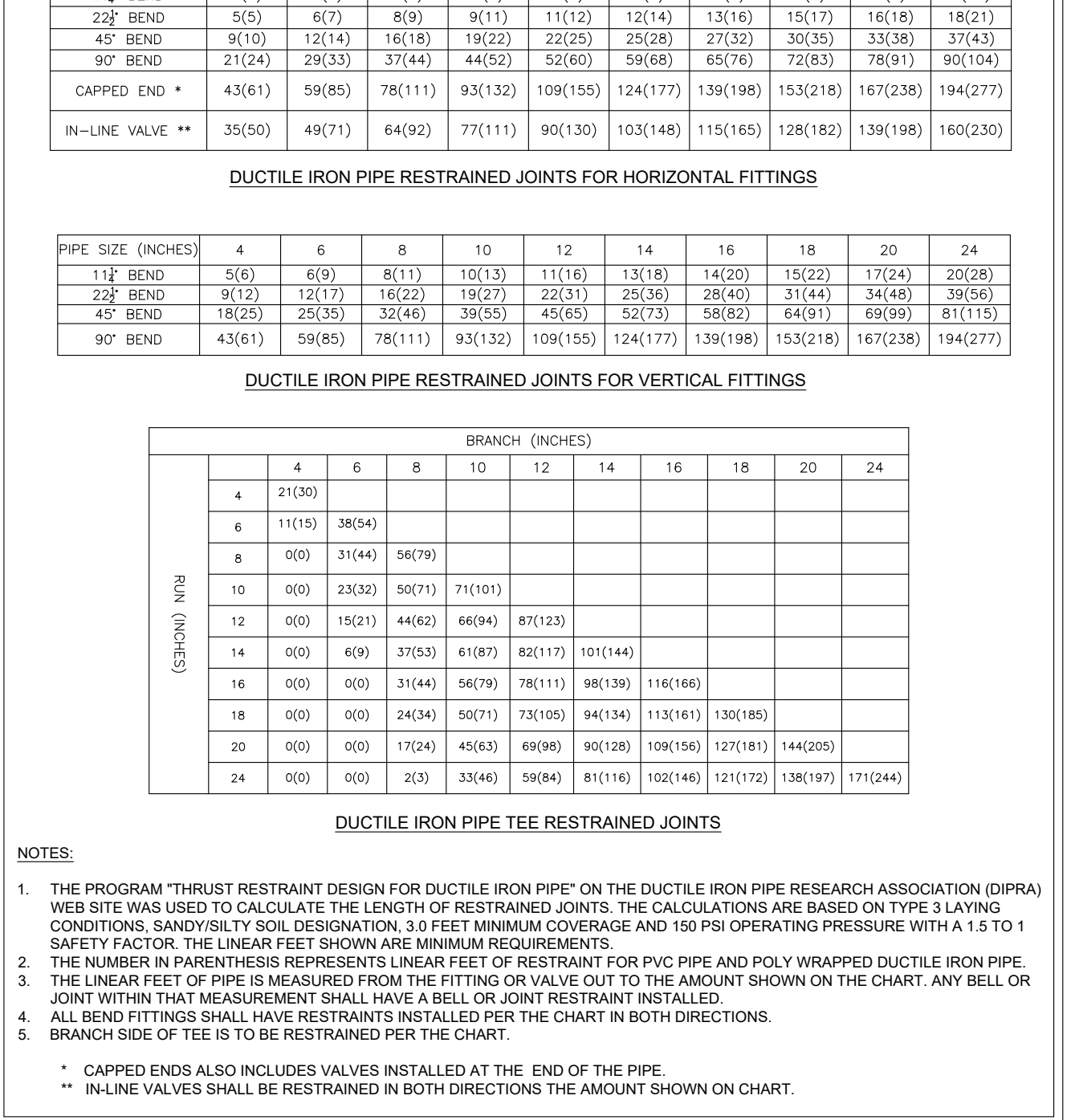

UTILITY DETAILS 2

DR DENNIS WILFONG CENTER FOR SUCCESS

Professional Engineer
No. 89405
STATE OF FLORIDA
Professional Seal

Engineering
Planning
Surveying
Environmental
Transportation
Construction Management
Coastal
engineering associates, inc.
966 Candlelight Boulevard - Brooksville, Florida 34601
(352) 796-9423 Fax (352) 796-8359
EE-0000142

REUSE OF DOCUMENT
THIS DOCUMENT, COMPRISED OF THE DRAWINGS AND SPECIFICATIONS, IS THE PROPERTY OF COASTAL ENGINEERING ASSOCIATES, INC. AND IS NOT TO BE REPRODUCED OR TRANSMITTED IN ANY FORM OR BY ANY MEANS, WITHOUT THE WRITTEN PERMISSION OF COASTAL ENGINEERING ASSOCIATES, INC. DRAWINGS, INVAID UNLESS SIGNED, DATED & SEALED BY REGISTERED PROFESSIONAL ENGINEER.

DATE	REV. BY/REV. NO.	DESCRIPTION
09/13/22	LEE 1	BID SET
10-13-22	LEE 2	ADDRESSES HCID COMMENTS ADJUST UTIL/STORM LOCATIONS ON SH. DRIVE
1-24-23	LEE 3	ADDRESSES HCID COMMENTS, ADD ALT BID SIDEWALK

WHEN PRINTED TO SCALE, DRAWING SIZE SHALL BE 22" X 34"

SHEET C-19

JOB No. 21115

REGULATORY REQUIREMENTS FOR CONSTRUCTION PROJECTS INCLUDE:

ENVIRONMENTAL RESOURCE PERMIT (ERP) CONSTRUCTION SURFACE WATER MANAGEMENT PLAN

Table with 2 columns: Field (PURPOSE, REGULATORY AGENCY, APPLIES TO, RESPONSIBLE ENTITY, REQUIREMENTS) and Description.

MAJOR COMPONENTS OF THE CSWMP

- 1) SITE PLAN.
2) TOPOGRAPHY AND HYDROLOGIC DATA
3) CONSTRUCTION DETAILS.
4) PROCEDURES TO CONTROL EROSION AND SEDIMENTATION.
5) PROCEDURES FOR STORMWATER MANAGEMENT.
6) MAINTENANCE PROCEDURES.
7) INSPECTION RECORDS.

SEE "THE FLORIDA STORMWATER EROSION AND SEDIMENTATION CONTROL INSPECTOR'S MANUAL", APRIL 2006 (OR LATEST EDITION) FOR ADDITIONAL INFORMATION. AND

CHAPTER 6, "THE FLORIDA DEVELOPMENT MANUAL: A GUIDE TO SOUND LAND AND WATER MANAGEMENT".(FDEP 1988) CONSTRUCTION SURFACE WATER MANAGEMENT RESPONSIBLE ENTITY

NOTE TO CONTRACTOR: A NATIONAL POLLUTION DISCHARGE ELIMINATION SYSTEM (NPDES) PERMIT IS NOT PART OF THE PERMITTING OBTAINED WITH THIS PLAN SET. THEREFORE, THE CONTRACTOR IS ADVISED THAT AN NPDES CONSTRUCTION PERMIT MAY BE REQUIRED FOR THIS PROJECT AND THAT THE CONTRACTOR IS RESPONSIBLE FOR APPLYING FOR AND ADHERING TO THIS PERMIT.

THE INFORMATION PROVIDED IN THE SWPPP NOTES AND DETAILS SHEETS ARE FOR COMPLIANCE WITH ENVIRONMENTAL RESOURCE PERMITTING UNDER CHAPTER 62-333, F.A.C. AND MAY BE USED AS A REFERENCE FOR COMPLIANCE WITH NPDES PERMITTING BUT ARE NOT NECESSARILY INCLUSIVE OF ALL NPDES REQUIREMENTS.

NATIONAL POLLUTION DISCHARGE ELIMINATION SYSTEM (NPDES)

Table with 2 columns: Field (PURPOSE, REGULATORY AGENCY, APPLIES TO, RESPONSIBLE ENTITY, REQUIREMENTS) and Description.

MAJOR COMPONENTS OF THE SWPPP

- 1) SITE PLAN.
2) TOPOGRAPHY AND HYDROLOGIC DATA
3) CONSTRUCTION DETAILS.
4) PROCEDURES TO CONTROL EROSION AND SEDIMENTATION.
5) MEASURES TO CONTROL OTHER POLLUTANTS.
6) MAINTENANCE PROCEDURES.
7) INSPECTION RECORDS.
8) OPERATOR CERTIFICATION.

SEE "GENERIC PERMIT FOR STORMWATER DISCHARGE FROM LARGE AND SMALL CONSTRUCTION ACTIVITIES", MAY 2003 (OR LATEST EDITION) FOR ADDITIONAL INFORMATION.

COMPLIANCE WITH NPDES GENERAL PERMIT CONDITIONS FOR CONSTRUCTION SITES SHALL BE THE CONTRACTOR'S RESPONSIBILITY INCLUDING SUBMITTAL OF THE NPDES NOTICES OF INTENT (NOI) AND TERMINATION (NOT) TO FDEP IN ACCORDANCE WITH STATE AND FEDERAL REGULATIONS.

CONTRACTOR IS ADVISED THAT THIS CONSTRUCTION PLAN SET DOES NOT FULFILL ALL REQUIREMENTS OF THE SWPPP. TO ENSURE COMPLIANCE, ADDITIONAL ITEMS TO BE SUPPLIED AND MAINTAINED ON SITE BY THE CONTRACTOR SHALL INCLUDE:

- 1. Certification Statement.
2. Subcontractor's Statement.
3. Records.
4. Amendments

The following documents may be consulted for additional guidance:

- WWW.DEP.STATE.FL.US/LEGAL/RULES/SHARED/62-621/62-621.PDF
WWW.DEP.STATE.FL.US/WATER/STORMWATER/NPDES/DOCS/SWPPPTRAINING.PDF
OR FDEP CAN BE CONTACTED AT 1-850-245-7522 FOR ANY NPDES PERMIT REQUIREMENTS.

INFORMATION CONTAINED IN THESE CONSTRUCTION PLANS IS INTENDED TO PROVIDE A STARTING POINT FOR THE CSWMP AND SWPP PLANS. IN ORDER TO FULLY COMPLY WITH ALL ASPECTS OF CSWMP AND SWPPP REQUIREMENTS, ADDITIONAL ITEMS SHALL BE PROVIDED BY THE RESPONSIBLE ENTITY TO INCLUDE: INSPECTION RECORDS, UPDATES / MODIFICATIONS, AND CERTIFICATIONS.

REFERENCES MADE TO THE "PLAN" IN THE FOLLOWING NOTES REFERS BOTH TO THE CSWMP AND SWPPP AND SHALL BE INTERCHANGEABLE. THE "PLAN" COMPONENTS PROVIDED BY THE ENGINEER INCLUDE SITE DATA, STORMWATER MANAGEMENT EROSION/SEDIMENT CONTROL INSTRUCTIONS, DETAILS, AND NOTES AS PRESENTED THROUGHOUT THIS CONSTRUCTION PLAN SET.

"PLAN" AMENDMENTS

THE PLAN SHALL BE AMENDED WHENEVER THERE IS A CHANGE IN DESIGN, CONSTRUCTION, OPERATION, OR MAINTENANCE, WHICH HAS A SIGNIFICANT EFFECT ON THE POTENTIAL FOR DISCHARGE OF POLLUTANTS TO SURFACE WATERS OF THE STATE OR MUNICIPAL SEPARATE STORM SEWER SYSTEM (MS4). THE PLAN ALSO SHALL BE AMENDED IF IT PROVES TO BE INEFFECTIVE OR TO INDICATE ANY NEW CONTRACTOR AND/OR SUBCONTRACTOR IMPLEMENTING CONTROL MEASURES.

SITE DATA

PROJECT NAME: DR DENNIS WILFONG CENTER FOR SUCCESS
PROJECT DESCRIPTION: PROPOSED EDUCATION FACILITY MASTER PLAN PROJECT
LOCATION: 18-23S.-18E.

PROJECT SIZE: ± 20.0 AC SIZE OF DISTURBED AREA: ± 20.0 AC

SITE MAP: SEE CONSTRUCTION PLANS COVER SHEET
EXISTING TOPOGRAPHY: SEE CONSTRUCTION PLAN SHEET C-03

PROPOSED TOPOGRAPHY: SEE LOT GRADING AND DRAINAGE PLANS

PREDEVELOPMENT DRAINAGE MAP: SEE STORMWATER MANAGEMENT REPORT EXHIBIT

POST-DEVELOPMENT DRAINAGE MAP: SEE STORMWATER MANAGEMENT REPORT EXHIBIT

Table with 2 columns: SCS SOIL DATA (#, NAME) and HSG (A/D, A, C/D).

ADDITIONAL DATA INCLUDING GEOTECHNICAL STUDY AND STORMWATER MANAGEMENT REPORT ARE AVAILABLE FROM THE ENGINEER.

RUNOFF COEFFICIENTS:
PREDEVELOPMENT C VALUE = 0.1 UNPAVED
POST-DEVELOPMENT C VALUE = 0.1 UNPAVED
= 0.6 DEVELOPED LOTS = 0.5 WITHIN PAVED R/W

DISCHARGE POINTS AND RECEIVING WATER OR MS4 (UP TO 100 YR / 24 HR EVENT)
CLOSED BASIN NO OFF-SITE DISCHARGE

FDOT PRECIPITATION ZONE: ZONE 6

WATER MANAGEMENT DISTRICT RAINFALL DATA:
2.3 YR / 24 HR = 4.7 INCHES
5 YR / 24 HR = 5.6 INCHES
10 YR / 24 HR = 7.5 INCHES
25 YR / 24 HR = 9.5 INCHES
100 YR / 24 HR = 12.8 INCHES

CONSTRUCTION ACTIVITIES

- 1. Sequence of Major Soil Disturbing Activities
2. Areas of Soil Disturbing Activities
3. Areas to be Stabilized

CONTROLS

The following discussion defines general guidelines for the use of erosion/sediment controls and stabilization.

- 1. Temporary and permanent stabilization practices.
2. Structural Controls.

Sheet flow areas may require additional silt fence.

NOTE: Additional silt fence may also be required to designate limits of construction, protect trees, or satisfy local development requirements. Stockpile areas shall include silt fence around the perimeter.

- B. Synthetic Hay Bales
C. Rock Bags
D. Turbidity Barriers
3. Sediment Basins for areas disturbing 10 acres or more.
4. Permanent storm water management controls.
5. Other Pollutant Controls.

A. Waste Disposal:
The Contractor shall be responsible for maintaining field records of their SWPPP activities including disposal of construction debris and waste.

The Contractor shall provide litter control and collection within the project boundaries during construction activities. Any fertilizer, hydrocarbon, or other chemical containers shall be disposed of by the contractor according to EPA standard practices as detailed by the manufacturer.

B. Offsite Vehicle Tracking:
Loaded haul trucks shall be covered by a tarpaulin. In addition, the Contractor shall utilize one or more of the following acceptable methods of control:

- 1. Excess dirt on paved roads shall be removed daily.
2. Soil Tracking Prevention Device may be used where vehicles leave the project area (or enter nearest paved road).
3. Contractor shall provide pollution control by implementing dust control with water application while dust generating activities are conducted.

C. Herbicides / Pesticides:
Application rates shall conform to applicable local, state and federal regulations.

D. Toxic Substances:
Storage, application, generation, migration of all toxic substances shall conform to applicable local, state ad federal regulations. Containment areas shall be provided whenever potentially hazardous materials are stored on site.

E. Stockpiles:
Stockpiling topsoil shall be stockpiled so that natural drainage is not obstructed and no offsite sedimentation occurs. Soil stockpiles should be protected or adequately covered from stormwater during construction.

F. Dust Control:
In addition to "Temporary and permanent stabilization practices" described in Item 1 above, during construction/excavation operations periodic watering of exposed soil will be used to control dust.

6. Non-stormwater Discharges.
No non-stormwater discharges to surface waters, wetlands or the MS4 shall be allowed except as specifically approved by applicable permits and regulations.

MAINTENANCE

The Contractor shall be responsible for daily inspection and maintenance of all control devices throughout the construction phase and removal of control devices when no longer necessary.

The following practices shall be used to maintain controls.

- 1. The Contractor shall maintain rain gages on the project site and keep a record of daily rainfall.
2. The Contractor shall check and ensure proper operation of the controls.
3. Built-up sediment shall be removed when it has reached 1/3 the height of barrier.
4. Any controls which are not functioning as intended shall be repaired or replaced.
5. Sediment sumps, if designed and installed, should have sediment removed as necessary to allow for efficient removal of suspended particles.

Temporary and permanent seeding shall be inspected for bare spots, washouts, and healthy growth. Soil tracking prevention devices shall be maintained to prevent clogging of rock bedding which may impede usefulness of the structure.

NOTE: The PERMITTEE is responsible for ensuring that all controls are properly maintained during and after construction.

INSPECTION AND DOCUMENTATION PROCEDURES

The Contractor shall be responsible for completing weekly inspection report form and maintaining documentation for 3 years following final stabilization. The Contractor shall submit copies of these reports to the owner prior to final payment for work shown within these construction plans.

NOTE: For NPDES, a significant rainfall shall be 0.5 inches or greater. For ERP, a significant rainfall shall be 0.25 inches or greater. To eliminate confusion, Contractor is advised to carryout inspections after rainfall exceeding 0.25 inches.

Where sites have been permanently stabilized, inspections/reports shall be conducted at least once per month until construction activities have ceased and NOT has been submitted.

- Minimum inspection requirements shall include:
- Points of discharge to waters of the State.
- Points of discharge to the MS4 (municipal storm sewer).
- Disturbed areas of the site that have not been stabilized.
- Areas used for storage of materials that may create a pollution source (i.e. stockpiles, fuel drums, construction debris) and are exposed to rainfall.
- Structural Controls
- Storm water Management Controls
- Locations where vehicles enter and exit the site.

The Contractor shall initiate repairs / corrections within 24 hours of any items found to be in non-compliance with the associated permit requirements. If inspections indicate that the installed stabilization and structural practices are not sufficient to minimize erosion, retain sediment, and prevent the discharge of pollutants Contractor shall complete corrective measures as needed.

NOTE: Specific conditions of all permits may require additional activities above and beyond those outlined above. Check all permit conditions as issued by regulatory agencies to ensure compliance.

SWPP NOTES
DR DENNIS WILFONG CENTER
FOR SUCCESS

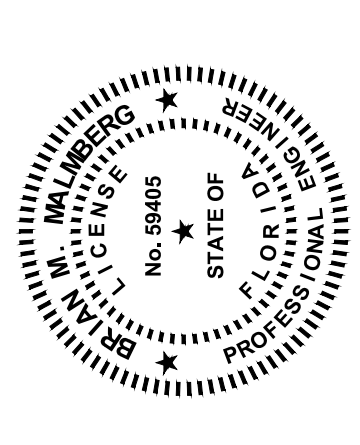

Coastal engineering associates, inc.
966 Candlelight Boulevard - Brooksville - Florida 34601
(352) 796-9423 - Fax (352) 799-8359
EB-0000142

REUSE OF DOCUMENT
THIS DOCUMENT COMPRISED OF THE INFORMATION CONTAINED HEREIN IS AN INSTRUMENT OF PROFESSIONAL SERVICE OF THE ASSOCIATES, INC. AND IS NOT TO BE USED, IN WHOLE OR IN PART FOR ANY OTHER PROJECT WITHOUT THE WRITTEN AUTHORIZATION OF COASTAL ENGINEERING ASSOCIATES, INC.

Table with 4 columns: DATE, REV. BY/REV. NO., BID SET, REVISION.

SHEET
C-20

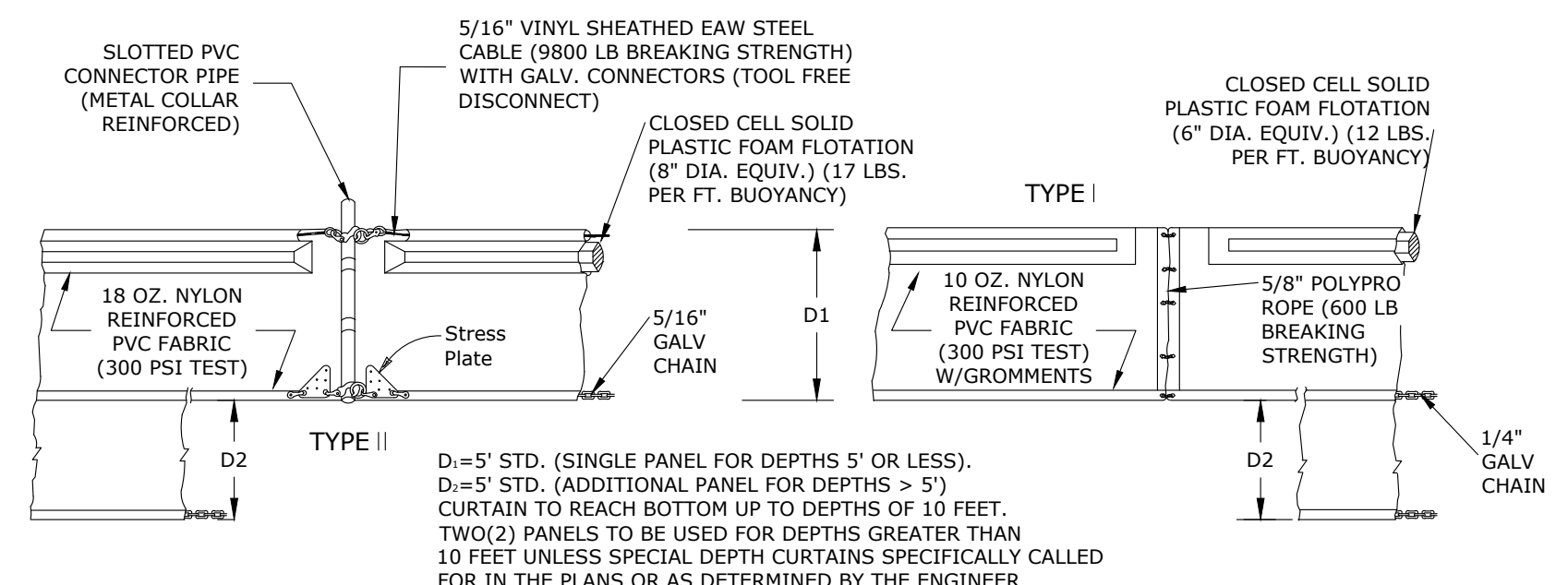

NOTICE: COMPONENTS OF TYPED I AND II MAY BE SIMILAR OR IDENTICAL TO PROPRIETARY DESIGNS. ANY INFRINGEMENT OF THE PROPRIETARY RIGHTS OF THE DESIGNER SHALL BE THE SOLE RESPONSIBILITY OF THE USER. SUBSTITUTIONS FOR TYPES I AND II SHALL BE AS APPROVED BY THE ENGINEER.

FLOATING TURBIDITY BARRIERS
N. T. S.

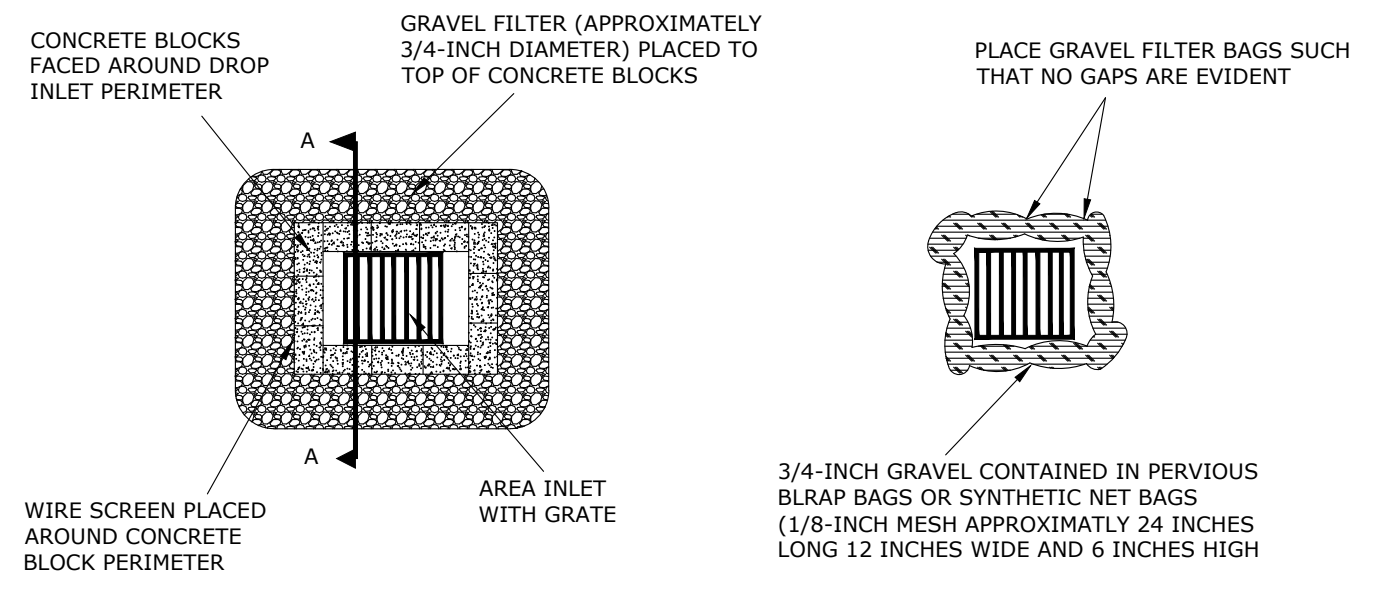

CONCRETE BLOCK FILTER

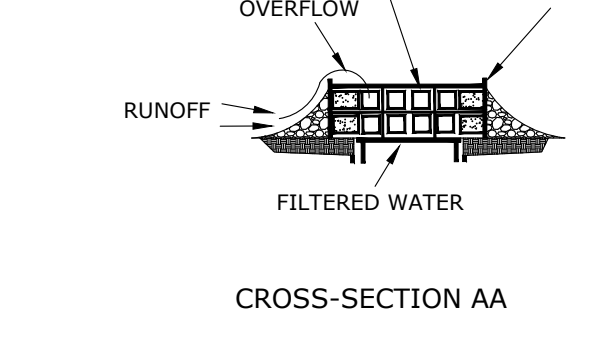

GRAVEL FILTER BAGS

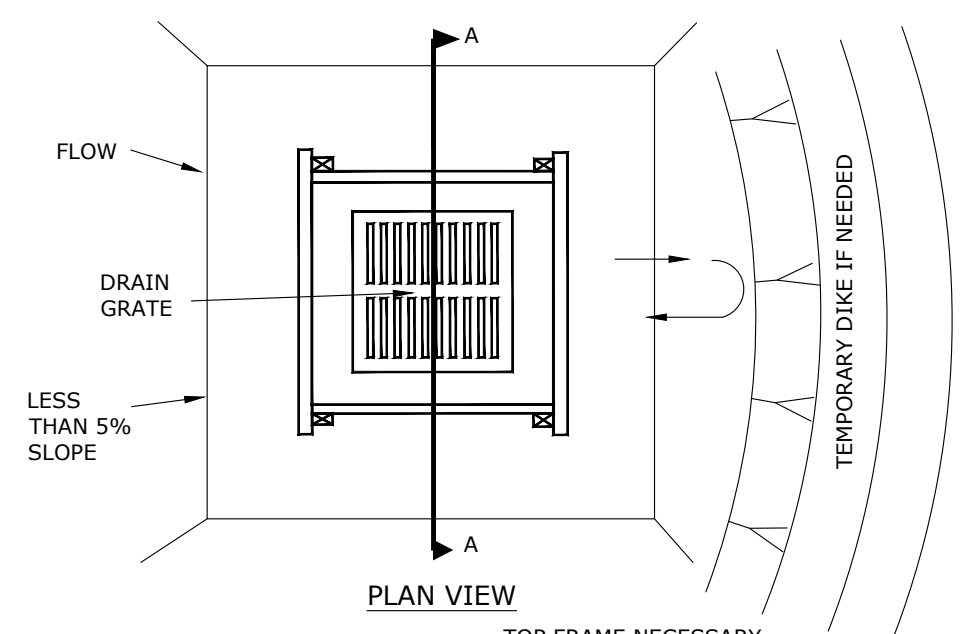

SILT FENCE DROP INLET SEDIMENT BARRIER

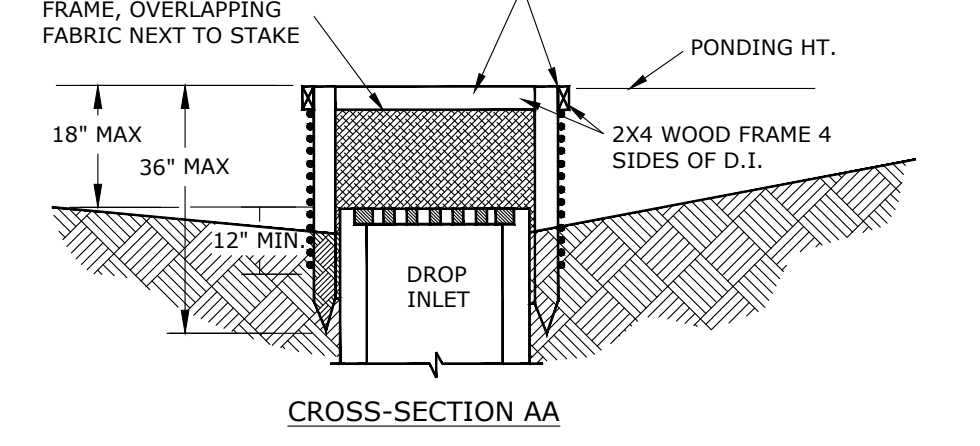

NOTES:
1. DROP INLET SEDIMENT BARRIERS ARE TO BE USED FOR SMALL, NEARLY LEVEL DRAINAGE AREAS. (LESS THAN 5%). THIS METHOD SHALL NOT APPLY TO INLETS RECEIVING CONCENTRATED FLOWS, SUCH AS IN STREET OR HIGHWAY OR MEDIANS.
2. USE 2X4 WOOD OR EQUIVALENT METAL STAKES, (3 FT. MIN LENGTH)
3. INSTALL 2X4 WOOD TOP FRAME TO INSURE STABILITY.
4. THE TOP OF THE FRAME (PONDING HEIGHT) MUST BE WELL BELOW THE GROUND ELEVATION DOWNSLOPE TO PREVENT RUNOFF FROM BY-PASSING THE INLET. A TEMPORARY DIKE MAY BE NECESSARY ON THE DOWNSLOPE SIDE OF THE STRUCTURE.

NOTE:
SOIL TRACKING DEVICE SHALL BE INSTALLED WHERE CONSTRUCTION VEHICLES ENTER PUBLIC ROADS FROM DISTURBED SITE AREAS UNLESS OTHER METHODS FROM SHEET 9 "CONTROLS" ITEM 5.B ARE UTILIZED.

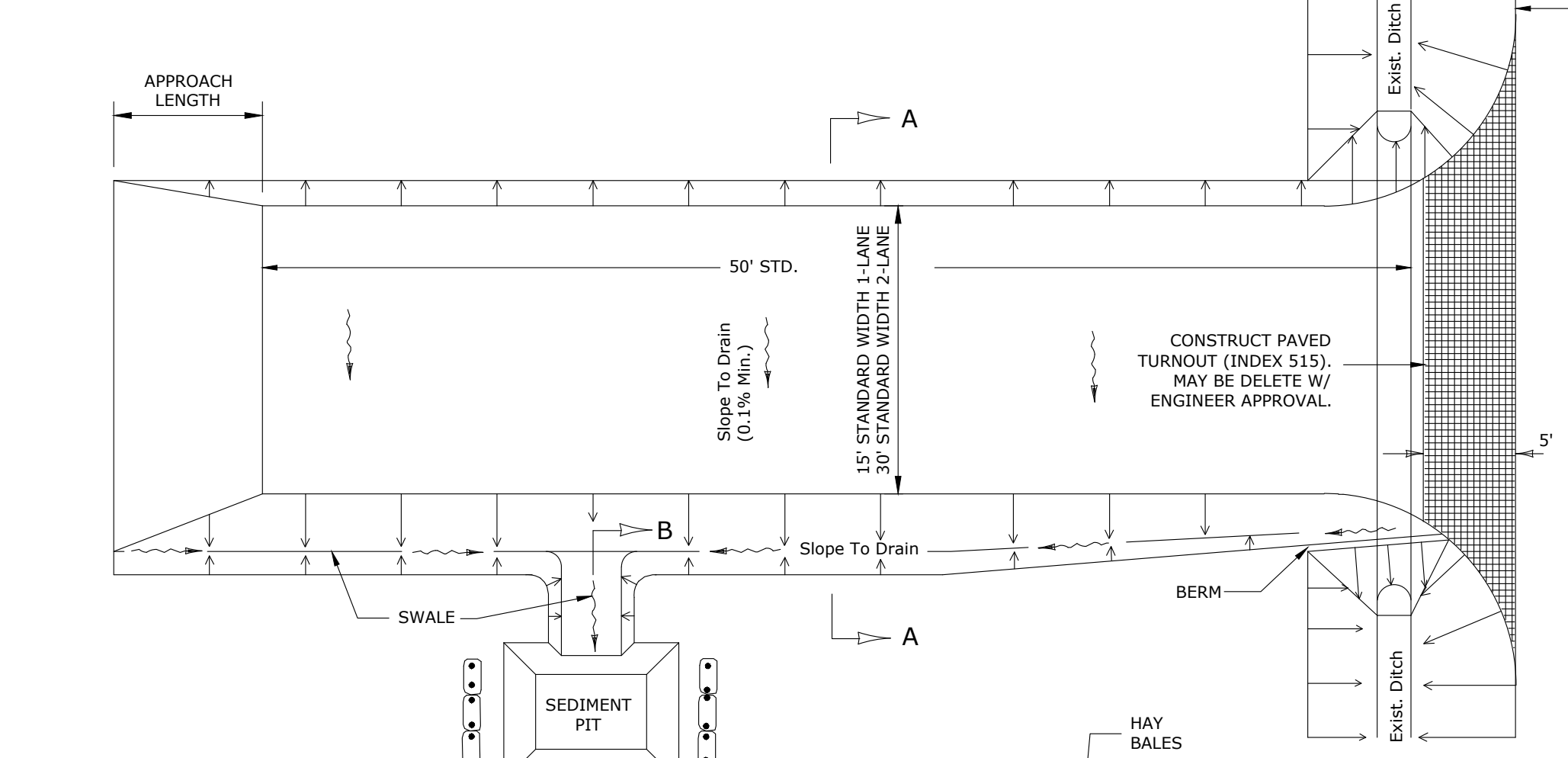

SOIL TRACKING PREVENTION DEVICE
N. T. S.

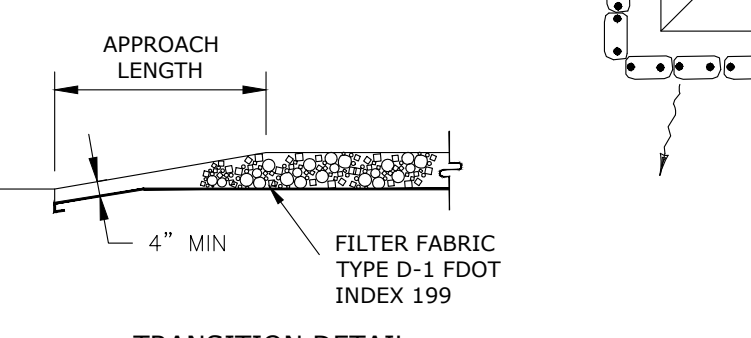

TRANSITION DETAIL

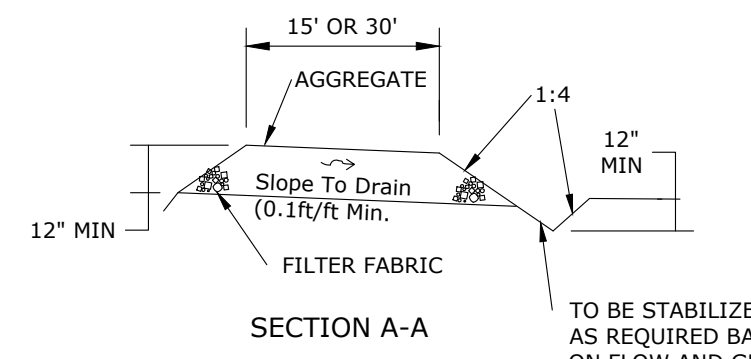

SECTION A-A

SECTION B-B

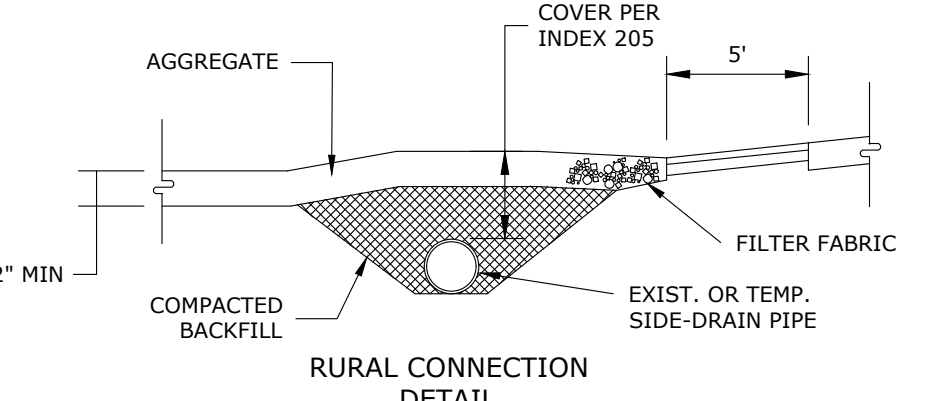

RURAL CONNECTION DETAIL

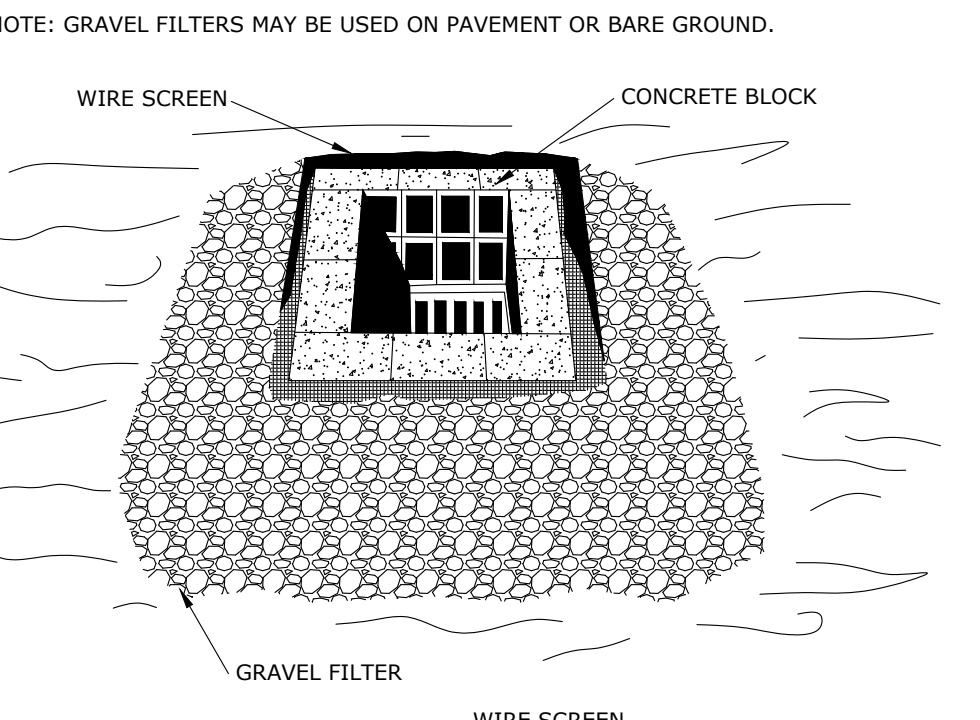

BLOCK AND GRAVEL DROP INLET SEDIMENT FILTER

THIS METHOD OF INLET PROTECTION IS APPLICABLE WHERE HEAVY CONCENTRATED FLOWS ARE EXPECTED, AND WHERE AN OVERFLOW CAPACITY NECESSARY TO PREVENT EXCESSIVE PONDING AROUND THE STRUCTURE.
* GRAVEL SHALL BE FDOT #3, #357, OR #5 COARSE AGGREGATE.

- PLACE CONCRETE BLOCKS LENGTHWISE ON THEIR SIDES IN A SINGLE ROW AROUND THE PERIMETER OF THE INLET, WITH THE END OF ADJACENT BLOCKS ABUTTING. THE HEIGHT OF THE BARRIER CAN BE VARIED, DEPENDING ON DESIGN NEEDS, BY STACKING COMBINATION OF 4.8, AND 12 INCH WIDE (10, 20, AND 30 CM) BLOCKS. THE BARRIER OF BLOCKS SHALL BE AT LEAST 12 INCHES (30 CM) HIGH AND NO GREATER THAN 24 INCHES (60 CM) HIGH.
- WIRE MESH SHALL BE PLACED OVER THE OUTSIDE VERTICAL FACE (WEBBING) OF THE CONCRETE BLOCKS TO PREVENT STONE FROM BEING WASHED THROUGH THE HOLES IN THE BLOCKS. HARDWARE CLOTH OR COMPARABLE WIRE MESH WITH 1/2 INCH (13 MM) OPENINGS SHALL BE USED.
- STONE SHALL BE PILED AGAINST THE WIRE TO THE TOP OF THE BLOCK BARRIER. SUITABLE COARSE AGGREGATE SHALL BE USED.
- IF THE STONE FILTER BECOMES CLOGGED WITH SEDIMENT SO THAT IT NO LONGER ADEQUATELY PERFORMS ITS FUNCTION, THE STONE MUST BE PULLED AWAY FROM THE BLOCKS, CLEANED AND REPLACED.

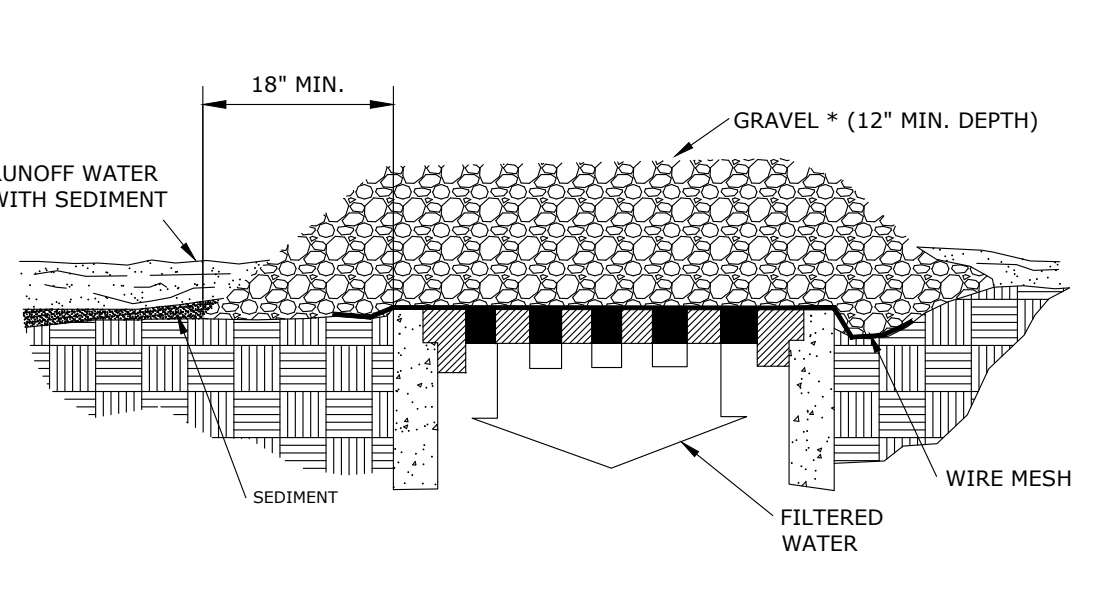

GRAVEL AND WIRE MESH DROP INLET SEDIMENT FILTER

THIS METHOD OF INLET PROTECTION IS APPLICABLE WHERE HEAVY CONCENTRATED FLOWS ARE EXPECTED, BUT NOT WHERE PONDING AROUND THE STRUCTURE MIGHT CAUSE EXCESSIVE INCONVENIENCE OR DAMAGE TO ADJACENT STRUCTURES AND UNPROTECTED AREAS.
* GRAVEL SHALL BE FDOT #3, #357, OR #5 COARSE AGGREGATE.

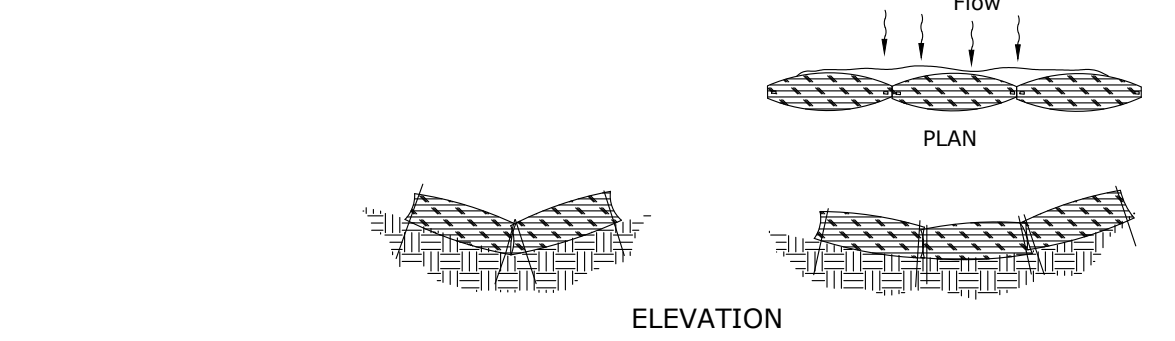

BARRIERS FOR SWALES
N. T. S.

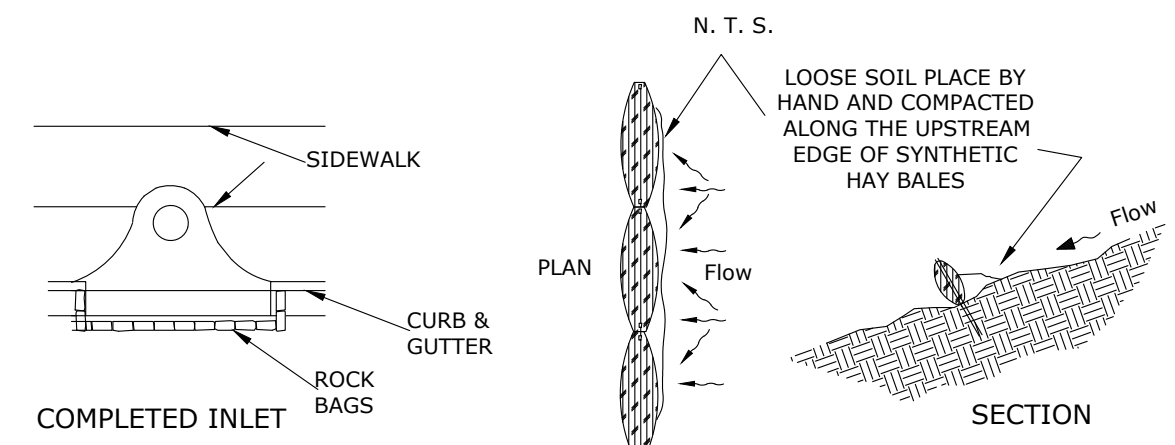

BARRIERS FOR INLETS
N. T. S.

BARRIERS FOR SLOPES
N. T. S.

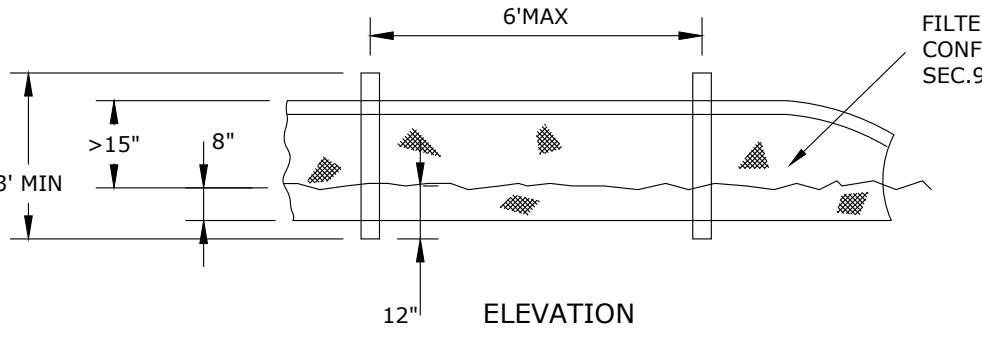

TYPE III SILT FENCE
N. T. S.

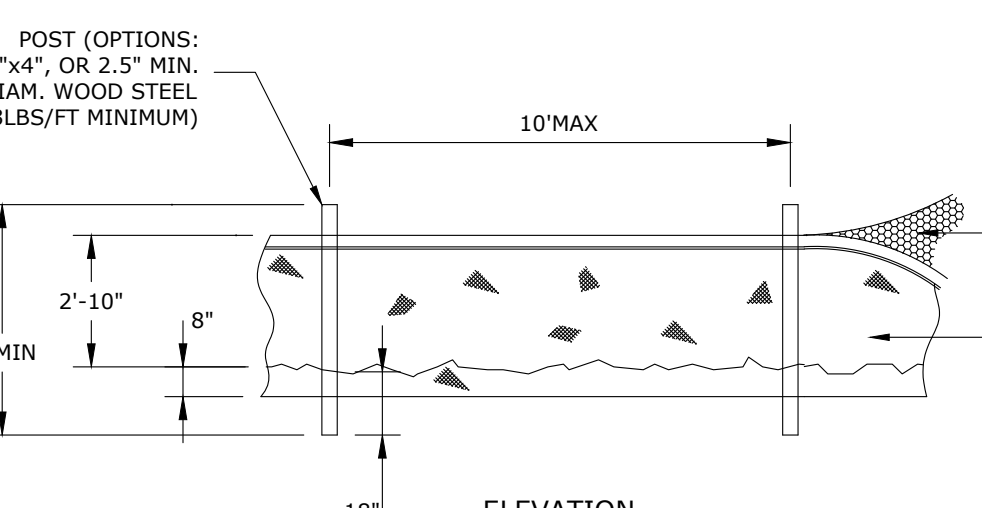

TYPE IV SILT FENCE
N. T. S.

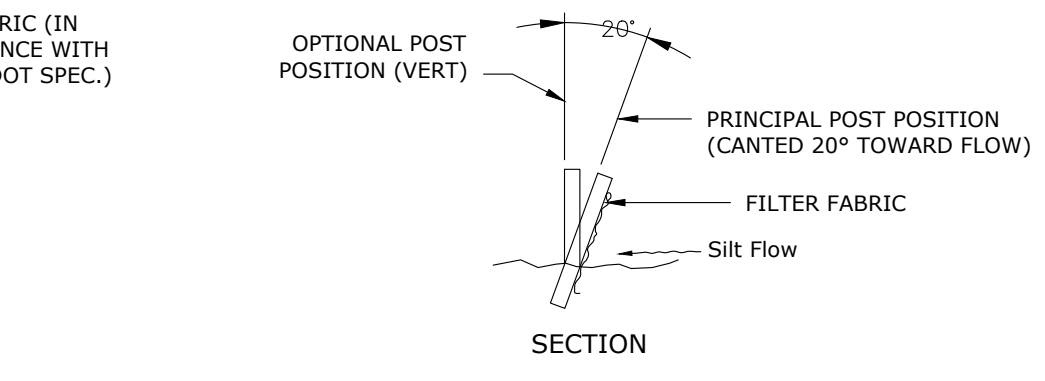

SECTION

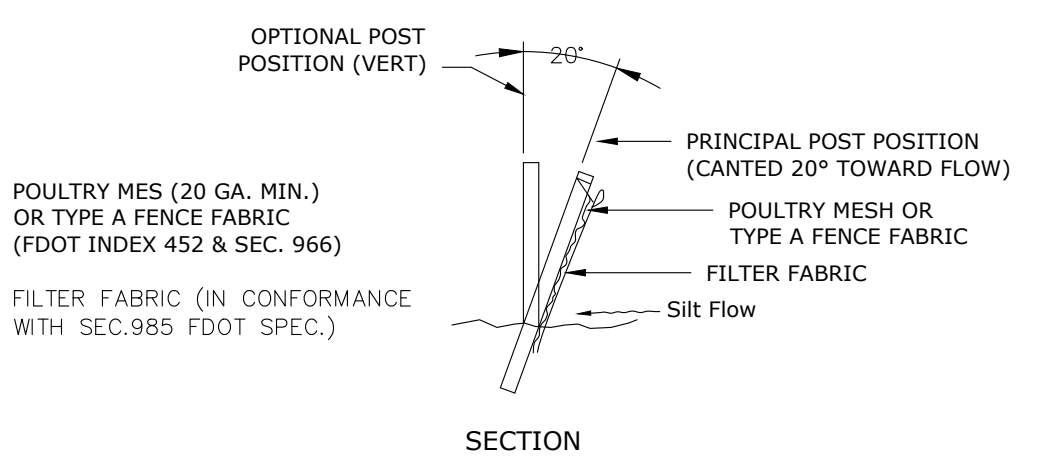

SECTION

NOTES:
1. FOR ADDITIONAL INFORMATION AND DETAILS, SEE F.D.E.P. BMP STANDARDS.
2. UNLESS SPECIFIED, HAY BARRIERS MAY BE USED IN LIEU OF SILT FENCES.
3. ADDITIONAL POSTS AND RAILS MAY BE NECESSARY TO SECURE AND SUPPORT BARRIERS.
4. ADDITIONAL FENCE LENGTHS MAY BE REQUIRED BY THE ENGINEER OR BY REGULATORY AGENCIES.
5. DO NOT DEPLOY IN A MANNER THAT SILT FENCES WILL ACT AS A DAM ACROSS PERMANENT FLOWING WATERCOURSES. SILT FENCES ARE TO BE USED AT UPLAND LOCATIONS AND TURBIDITY BARRIERS USED AT PERMANENT BODIES OF WATER.

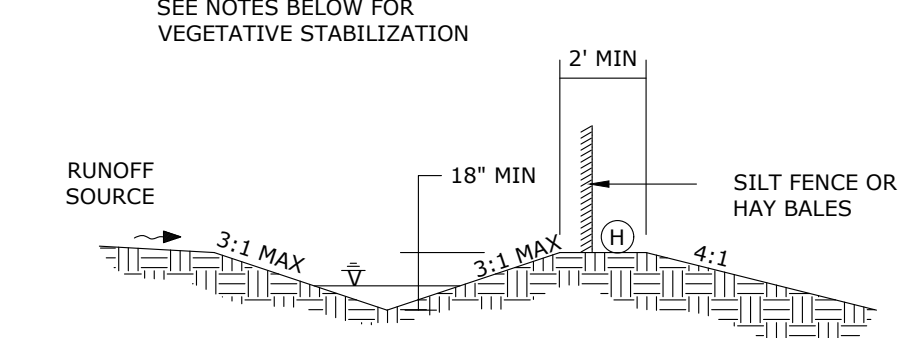

DIVERSION BERM
SECTION N. T. S.

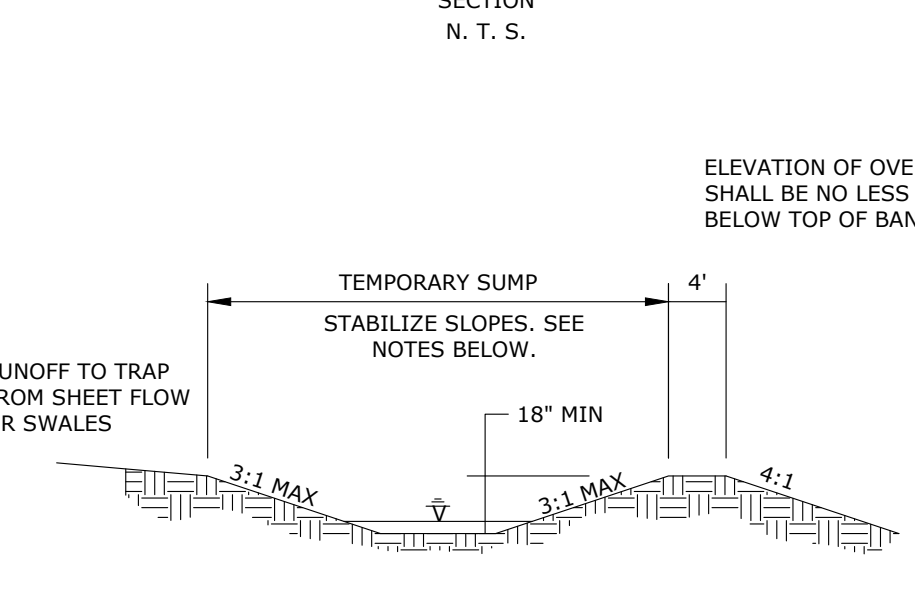

SEDIMENT TRAP
SECTION N. T. S.

NOTES:
1) WHEN BERMS, SWALES OR TRAPS SHALL REMAIN IN PLACE FOR MORE THAN 30 DAYS, ALL SLOPES SHALL BE STABILIZED WITH SOD OR SEED/MULCH.
2) VEGETATIVE STABILIZATION SHALL NOT BE REQUIRED FOR THE BOTTOM 6" OF SEDIMENT TRAPS.
3) REMOVE SEDIMENT FROM SWALES AND TRAPS WHEN THE DEPTH REACHES 6".
4) ADDITIONAL INFORMATION MAY BE OBTAINED FROM THE FLORIDA STORMWATER EROSION AND SEDIMENTATION CONTROL INSPECTOR'S MANUAL, JULY 2008.

SWPP DETAILS
DR DENNIS WILFONG CENTER FOR SUCCESS

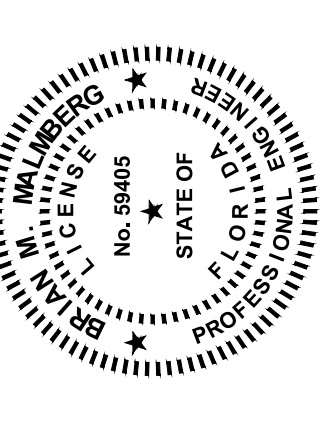

Coastal Engineering & Surveying
966 Candlelight Boulevard - Brooksville, Florida 34601
(352) 796-9423 - Fax (352) 799-8359
EE-000142

REUSE OF DOCUMENT
THIS DOCUMENT IS THE PROPERTY OF COASTAL ENGINEERING ASSOCIATES, INC. AND IS NOT TO BE REPRODUCED OR TRANSMITTED IN ANY FORM OR BY ANY MEANS, ELECTRONIC OR MECHANICAL, WITHOUT THE WRITTEN PERMISSION OF COASTAL ENGINEERING ASSOCIATES, INC.
DRAWING INVALID UNLESS SIGNED, DATED & SEALED BY REGISTERED PROFESSIONAL ENGINEER

DATE	REV. BY/REV. NO.	BID SET	REVISION
09/13/22	LEE	1	ADJUST UTIL/STORM
10-13-22	LEE	2	ADDRESS HCD COMMENTS
1-24-23	LEE	3	ADDRESS HCD COMMENTS, ADD ALT BID SIDEWALK

SHEET
C-21
21115

PRINTED: 02/07/2023 - 9:56am PRINTED BY: LH PATH: L:\21115\CITIZENS FOR SUCCESS\dwg\ENR\Curren\21115-EC.dwg

PRINTED: 02/07/2023 - 9:57am PRINTED BY: LH PATH: L:\21115\CITIZENS FOR SUCCESS\dwg\ENG\CURRENT\21115_SP.dwg

LEGEND:

- DRAINAGE BASIN
- EXISTING CONTOUR
- 100 YR. FLOOD PLAIN

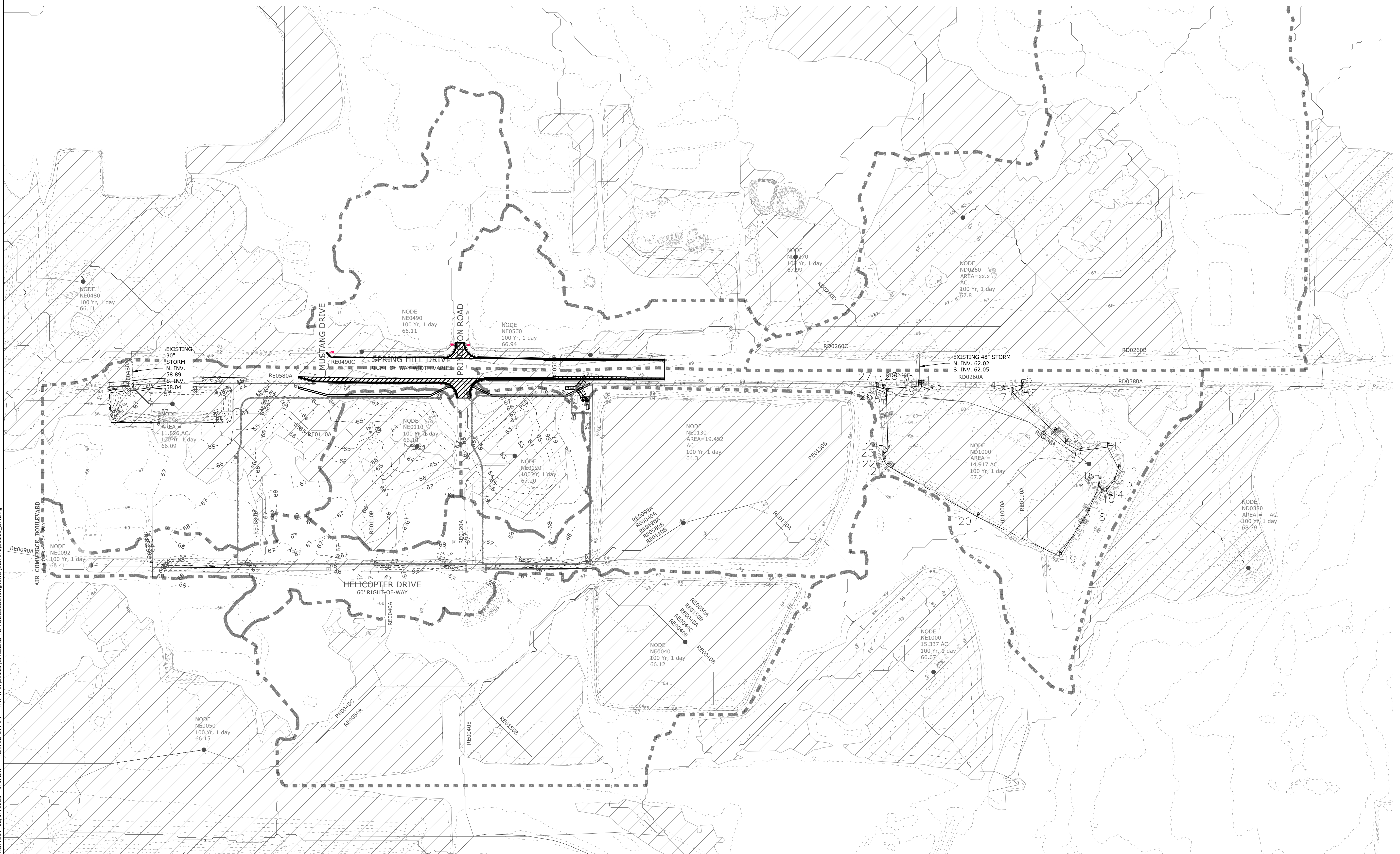
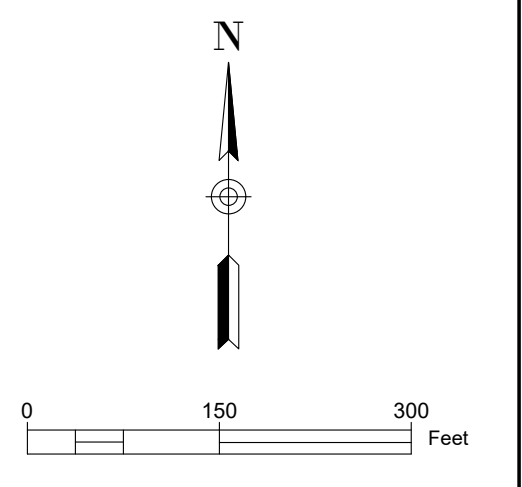

PRE-DEVELOPMENT DRAINAGE MAP
 DR DENNIS WILFONG CENTER FOR SUCCESS

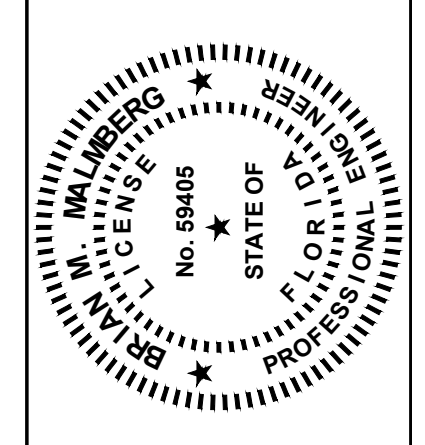

Coastal
 Engineering
 Surveying
 Environmental
 Transportation
 Construction Management
 engineering associates, inc. - Florida 34801
 966 Candlelight Boulevard - Brooksville - Fax (352) 799-8359
 EB-0000142

REUSE OF DOCUMENT
 THIS DOCUMENT, COMPRISING OF THE INCORPORATED IDEAS AND PROFESSIONAL SERVICE IS THE PROPERTY OF COASTAL ENGINEERING ASSOCIATES, INC. IT IS NOT TO BE USED, IN WHOLE OR IN PART, FOR ANY OTHER PURPOSE WITHOUT THE AUTHORIZATION OF COASTAL ENGINEERING ASSOCIATES, INC. DRAWING INVA. INC. UNLESS SIGNED, DATED & SEALED BY REGISTERED PROFESSIONAL ENGINEER.

DATE	REV. BY/REV. NO.	REVISION
09/13/22	LEE 1	BID SET
10-13-22	LEE 2	ADDRESS HOUD COMMENTS ADJUST UTIL/STORM
1-24-23	LEE 3	ADDRESS HOUD COMMENTS, ADD ALL BID SIDEWALK

WHEN PRINTED TO SCALE, DRAWING SIZE SHALL BE 22" X 34"

SHEET
C-22

JOB No: 21115

PRINTED: 02/07/2023 - 9:52am PRINTED BY: LH PATH: L:\21115\CITIZENS FOR SUCCESS\dwg\ENG\CURRENT\21115_SP.dwg

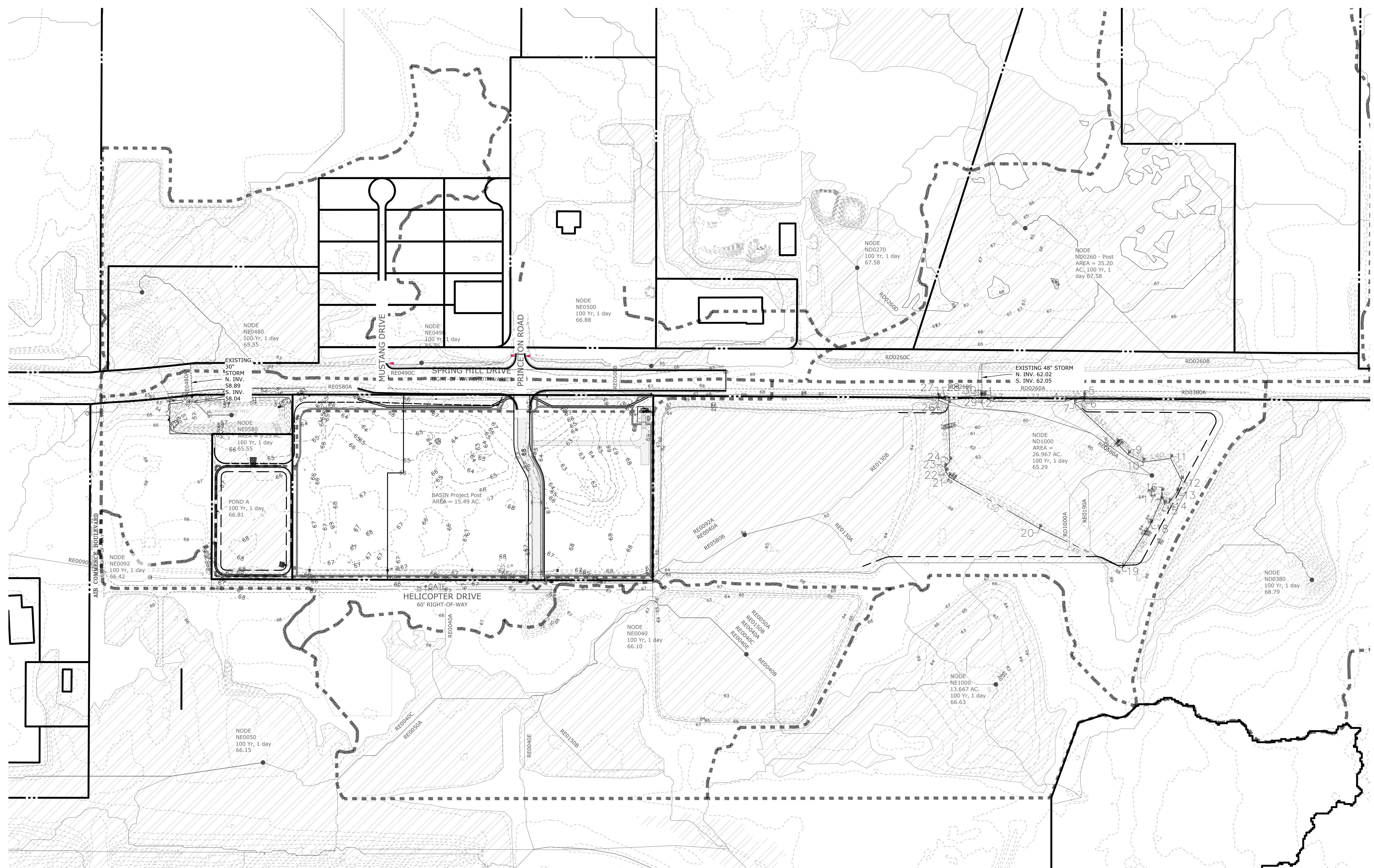

LEGEND:

- DRAINAGE BASIN
- EXISTING CONTOUR
- 100 YR. FLOOD PLAIN

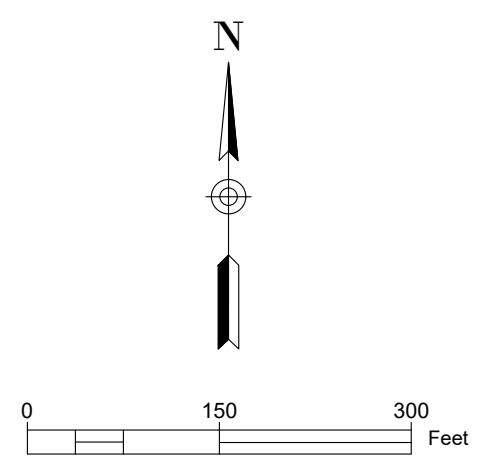

POST DEVELOPMENT DRAINAGE MAP

DR DENNIS WILFONG CENTER FOR SUCCESS

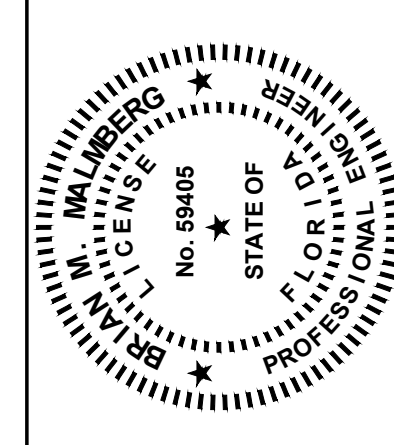

Coastal
 Engineering
 Surveying
 Environmental
 Transportation
 Construction Management

engineering associates, inc.
 966 Candlelight Boulevard - Brooksville - Florida 34601
 (352) 796-9423 - Fax (352) 799-8359
 EB-0000142

REUSE OF DOCUMENT
 THIS DOCUMENT, COMPRISING THE INCORPORATED IDEAS AND PROFESSIONAL SERVICE, IS THE PROPERTY OF F.C.D.A.S.T.A.L. IT IS NOT TO BE USED, IN WHOLE OR IN PART FOR ANY OTHER PURPOSE WITHOUT THE AUTHORIZATION OF F.C.D.A.S.T.A.L. COASTAL ENGINEERING ASSOCIATES, INC. DRAWING INVALED UNLESS SIGNED, DATED & SEALED BY REGISTERED PROFESSIONAL ENGINEER.

DATE	REV. BY/REV. NO.	REVISION
09/13/22	LEE 1	BID SET
10-13-22	LEE 2	ADDRESS HOUD COMMENTS ADJUST UTIL/STURM
1-24-23	LEE 3	ADDRESS HOUD COMMENTS, ADD ALL BID SIDEWALK

WHEN PRINTED TO SCALE, DRAWING SIZE SHALL BE 22" X 34"

SHEET C-23

JOB No: 21115

TIERRA

January 26, 2022

Coastal Engineering Associates, Inc.
966 Candlelight Boulevard
Brooksville, Florida 34601

Attn: Mr. Brian Malmberg, P.E.

**RE: Geotechnical Engineering Services Report
Citizens Center for Success – Roadway and Drainage
Hernando County, Florida
Tierra Project No. 6511-21-369**

Mr. Malmberg:

Tierra, Inc. (Tierra) has completed geotechnical engineering services for the above-referenced project. The results of our field exploration program and subsequent geotechnical recommendations are presented in this report.

Tierra appreciates the opportunity to be of service to Coastal Engineering Associates, Inc. on this project. We look forward to working with you on future projects. If you have any questions or comments regarding this report, please contact us at your earliest convenience.

Respectfully Submitted,

TIERRA, INC.



Tyler R. Jean, E.I.
Geotechnical Engineer Intern



Daniel R. Ruel, P.E.
Geotechnical Engineer
Florida License No. 82404



Kevin H. Scott, P.E.
Senior Geotechnical Engineer
Florida License No. 65514

PROJECT DESCRIPTION	2
Project Information	2
Scope of Services.....	2
REVIEW OF PUBLISHED DATA.....	2
USGS Quadrangle Map.....	2
USDA Soil Survey.....	3
SUBSURFACE EXPLORATION.....	3
Boring Location Plan	3
Soil Borings	3
Field Permeability Testing	4
RESULTS OF SUBSURFACE EXPLORATION	4
Soil Conditions.....	4
Groundwater Information	4
Seasonal High Groundwater Table Estimates.....	5
GPR Survey.....	5
EVALUATION AND RECOMMENDATIONS	5
General.....	5
Geologic Hazards	6
On Site Soil Suitability	6
Site Preparation.....	6
Pavement Considerations	7
Drainage and Groundwater Concerns	8
Backfill	8
Excavations and Temporary Side Slopes.....	8
REPORT LIMITATIONS	9
APPENDIX	
Boring Location Plan	
Soil Profiles	
Summary of Geotechnical Parameters	
GPR Survey Plan	

PROJECT DESCRIPTION

Project Information

The project consists of developing an educational center campus (Citizens Center for Success) on the north side of the Hernando County Airport in Hernando County, Florida. This report has been developed to provide geotechnical soils information pertaining to the drainage and roadway portions of the project.

Scope of Services

The objective of our study was to obtain information concerning subsurface conditions within the proposed drainage improvement areas and access roads in order to base engineering estimates and recommendations.

In order to meet the preceding objectives, we provided the following services:

1. Reviewed the “Masaryktown, Florida” Quadrangle Map published by the United States Geological Survey (USGS), as well as the Soil Survey of Hernando County, Florida, published by the United States Department of Agriculture (USDA) Natural Resources Conservation Service (NRCS).
2. Performed site reconnaissance and coordinated utility clearances with Sunshine One Call.
3. Performed a Ground Penetration Radar (GPR) survey along transect lines within each drainage improvement area.
4. Executed a program of subsurface exploration consisting of augers borings, Standard Penetration Test (SPT) borings, subsurface sampling, and field hydraulic conductivity testing.
5. Visually examined all recovered soil samples in the laboratory and classified the soils according to the Unified Soil Classification System (USCS).
6. Prepared this engineering report in accordance with the scope of services herein that summarizes the course of study pursued, the field data generated, subsurface conditions encountered and our engineering recommendations in each of the pertinent topic areas.

The scope of our services did not include an environmental assessment for determining the presence or absence of wetlands or hazardous or toxic materials in the soil, bedrock, groundwater, or air, on or below or around this site. Any statements in this report or on the boring logs regarding odors, colors, unusual or suspicious items or conditions are strictly for the information of our client.

REVIEW OF PUBLISHED DATA

USGS Quadrangle Map

Based on the “Masaryktown, Florida” USGS Quadrangle Map, the natural ground elevation at the project site is approximately +65 to +75 feet, National Geodetic Vertical Datum of 1929 (NGVD 29).

USDA Soil Survey

Based on a review of the Hernando County Soil Survey published by the USDA NRCS, there are four (4) primary soil-mapping units noted within the vicinity of the project site. The general soil descriptions as provided in the Soil Survey are presented in the following table:

SUMMARY OF USDA SOIL SURVEY HERNANDO COUNTY, FLORIDA								
USDA Map Symbol and Soil Name	Depth (in)	Soil Classification		Permeability (in/hr)		pH	Seasonal High Water Table	
		USCS	AASHTO	Low	High		Depth (feet)	Months
(14) Candler	0-5	SM, SP, SP-SM	A-2-4, A-3	6.0	50.0	4.5-6.0	>6.0	Jan-Dec
	5-74	SM, SP, SP-SM	A-2-4, A-3	6.0	50.0	4.5-6.0		
	74-80	SP-SM, SM, SP, SC-SM	A-2-4, A-3	6.0	20.0	4.5-6.0		
(29) Kendrick	0-7	SM, SP-SM	A-2-4, A-3	6.0	20.0	4.5-6.0	>6.0	Jan-Dec
	7-28	SM, SP-SM	A-2-4, A-3	6.0	20.0	4.5-6.0		
	28-73	SC	A-2-4, A-6, A-2-6	0.6	6.0	4.5-6.0		
	73-80	SC	A-6, A-2-6, A-2-4	0.6	2.0	4.5-6.0		
(32) Masaryk	0-3	SM	A-2-4	6.0	20.0	4.5-6.0	3.5-6.0	Jun-Oct
	3-70	SM	A-2-4	6.0	20.0	4.5-6.0		
	70-80	SC, SC-SM	A-2-4, A-4	0.2	2.0	4.5-5.0		
(36) Nobleton	0-7	SM, SP-SM	A-2-4	6.0	20.0	4.5-6.0	1.5-3.5	Jul-Oct
	7-33	SM, SP-SM	A-2-4	6.0	20.0	4.5-6.0		
	33-37	SC	A-2-6, A-6	0.2	2.0	3.5-5.5		
	37-60	CH, CL, SC	A-6, A-7	0.2	0.6	3.5-5.5		
	60-80	SC	A-2-6, A-6	0.2	2.0	3.5-5.5		
	80-85	SC, SC-SM	A-2-4, A-2-6, A-6	0.2	6.0	3.5-5.5		

It should be noted that information contained in the USDA NRCS Soil Survey may not be reflective of current soil and groundwater conditions, particularly if recent development in the project vicinity has modified existing soils or surface/subsurface drainage.

SUBSURFACE EXPLORATION

Boring Location Plan

Prior to commencing our subsurface explorations, a boring location plan was developed based on project information provided by Coastal Engineering Associates, Inc. The borings were located in the field by representatives of Tierra using hand-held, non-survey grade Global Positioning System (GPS) equipment with a manufacturer's reported accuracy of ± 10 feet. The approximate boring locations are presented on the **Boring Location Plan** in the **Appendix**.

Soil Borings

The subsurface conditions at the project site were explored with SPT borings and auger borings performed to depths ranging from approximately 20 to 60 feet and 2 to 6 feet below existing grades, respectively. The SPT borings were performed with the use of a mechanical drill rig using Bentonite Mud rotary drilling procedures. The soil sampling for the SPT borings was performed in accordance with American Society for Testing and Materials (ASTM) Test designation D-1586. SPT resistance N-values were taken at intervals of 2 feet to a depth of 10 feet and on intervals of 5 feet thereafter to the boring termination depth.

The auger borings were performed by manually advancing a bucket auger into the ground, typically in 6-inch increments. As each soil type was revealed, representative samples were sealed, labeled and transferred to our laboratory for classification and analyses. The results of the borings are presented on the **Soil Profiles** sheets in the **Appendix**.

Field Permeability Testing

Tierra performed three (3) constant head, open-end pipe hydraulic conductivity tests (U.S. Bureau of Reclamation Test Designation E-18, 1974) and seven (7) falling head, open-end hydraulic conductivity tests within the drainage improvement areas. The tests were performed at depths ranging from approximately 9 to 54 inches below the existing ground surface. The locations of the field permeability tests are depicted on the **Boring Location Plan**.

RESULTS OF SUBSURFACE EXPLORATION

Soil Conditions

The soil borings performed encountered variable conditions depending on the location of the boring. The **Soil Profiles** included in the **Appendix** should be reviewed for specific soil information in each area. The soil strata encountered within the borings performed at the project site are summarized in the following table:

Stratum Number	Soil Description	USCS Symbol
1	Light Gray to Brown Sand to Sand with Silt	SP/SP-SM
2	Light Gray to Brown Silty Sand	SM
3	Light Gray Clayey Sand	SC
4	Gray Clay	CL/CH
5	Weathered Limestone	---(1)
(1) The USCS does not provide nomenclature for natural limestone formation.		

The subsurface soil stratification is of a generalized nature to highlight the major subsurface stratification features and material characteristics. The **Soil Profiles** sheets provided in the **Appendix** should be reviewed for specific information at individual boring locations. These profiles include soil descriptions, stratifications and penetration resistances. The stratifications shown on the boring profiles represent the conditions only at the actual boring location. Variations did occur and should be expected between boring locations.

Groundwater Information

In the auger borings performed, the groundwater table was not encountered prior to the boring termination depth. As a result, GNE (Groundwater Not Encountered) is shown adjacent to these soil profiles. In addition, the groundwater table was not apparent prior to the introduction of drilling fluids

(at a depth of 10 feet) within the SPT borings; therefore, GNA (Groundwater Not Apparent) is indicated on the soil profile of these borings.

It should be noted that groundwater conditions will vary with environmental variations and seasonal conditions, such as the frequency and magnitude of rainfall patterns, as well as man-made influences (i.e. existing swales, drainage ponds, underdrains, and areas of covered soils, such as paved parking lots).

Seasonal High Groundwater Table Estimates

Based on the subsurface conditions encountered, the information provided in the Soil Survey of Hernando County, Florida published by the USDA and past experience with similar soil conditions, Tierra estimates the SHGWT within the project site to range from at or above existing grade to greater than 5 feet below current grades. The estimated SHGWT levels at individual auger boring locations are presented on the **Soil Profiles** sheet and on the **Summary of Geotechnical Parameters** table in the **Appendix**. It should be noted that the groundwater was not encountered within any of the borings performed. However, several of the borings performed during this study encountered clayey substrata often beginning at shallow depths and sometimes beginning at the ground surface. These soils have low permeability and will perch water following significant rain events. Modifications through excavations into the clayey soils will impact/change the perched SHGWT condition.

As previously noted, the locations of our borings were based on our hand-held GPS devices and should be considered approximate. There were observable elevation changes in the vicinity of the SHGWT boring locations. If the SHGWT levels are critical to design, Tierra recommends the locations of our borings be survey located.

GPR Survey

A GPR survey was performed to aid in the characterization of the subsurface conditions present within the proposed stormwater management areas. The purpose of the survey was to identify the lateral continuity and thickness of soil to evaluate any non-homogeneity that could be interpreted as indicative of potential karst activity. Tierra performed a total of twenty-two (22) GPR transect lines. The approximate transect locations are shown on the **GPR Survey Plan** in the **Appendix**.

EVALUATION AND RECOMMENDATIONS

General

The soil types encountered in the borings performed for this study appear suitable for the proposed development provided the geotechnical recommendations presented in this report are included in the design and implemented during construction.

In proposed pavement areas, it is recommended that a minimum clearance of at least 18 inches be provided between the top of the Strata 3 and 4 silty to clayey soils and the bottom of the base. In addition, due to the semi-confining/confining nature of the Strata 3 and 4 soils, underdrains may be necessary, depending on final grades, as part of the roadway design for the development. More discussion regarding pavement section design considerations are included later in this report.

Engineering evaluations and recommendations for the proposed improvements provided in the following sections of this report are based on the subsurface conditions encountered in the borings performed. If the final design criteria deviates from what is stated in this report, Tierra should be given the opportunity to review the new information and amend our recommendations, if necessary.

Geologic Hazards

The project site is within a region of Hernando County and West-Central Florida that can be characterized as having a moderate to high potential for sinkhole development. Tierra performed twenty-two (22) GPR transect lines within the project limits. The approximate transect locations are shown on **the GPR Survey Plan** sheet in the **Appendix**. Tierra identified three isolated potential anomalous features during the GPR survey. SPT borings were performed within these anomalous areas. Based on the SPT borings performed, conditions that would be considered indicative of karst activity were not encountered.

The results of the geotechnical field exploration performed for the project site do not indicate a higher potential for future sinkhole development than other similar sites in the geographic area. As such, preconstruction subsurface remediation is not warranted at this time.

Drainage Design Considerations

Tierra performed three (3) constant head, open-end pipe hydraulic conductivity tests (U.S. Bureau of Reclamation Test Designation E-18, 1974) and seven (7) falling head, open-end hydraulic conductivity tests within the drainage improvement areas. The field permeability test results along with pertinent information related to drainage design are provided on the **Summary of Geotechnical Parameters** table in the **Appendix**.

On Site Soil Suitability

The suitability of soils for reuse in construction should be evaluated against the project engineering fill requirements. Variations in the subsurface stratification should be expected between borings. All fill should be placed in accordance with current Hernando County specifications and/or jurisdictional requirements.

In general, the soils of Strata 1 and 2 (SP/SP-SM/SM) may be moved and used for grading purposes, site leveling, general engineering fill, structural fill and backfill in other areas, provided the fill is free of organic materials, clay, debris or any other material deemed unsuitable for construction and evaluated against engineering fill requirements. Stratum 2 (SM) may retain excessive moisture and be difficult to dry and compact. Stratum 2 should only be used above the water table level existing at the time of construction. The appropriate specifications should be consulted to determine the specific use/suitability of the soil types encountered during construction.

Site Preparation

Prior to construction, the location of any existing underground utilities within the construction area should be established. Material suitable for re-use may be stockpiled; however, any material stockpiled for re-use shall be tested for conformance to material specifications as indicated in the following paragraphs of this report. Provisions should then be made to relocate any interfering utility lines within the construction area to appropriate locations and backfilling the resulting excavations with compacted structural fill. In this regard, it should be noted that if abandoned underground pipes

are not properly removed or plugged, they might serve as conduits for subsurface erosion, which subsequently may result in excessive settlement.

The site should be cleared; this primarily includes removing any deleterious materials currently on the site (deleterious materials include but are not limited to organics, vegetation, trees and/or stumps, roots).

Pavement Considerations

Actual pavement section thickness should be provided by the design civil engineer based on traffic loads, volume, and the owner's design life requirements. The following sections represent minimum thicknesses representative of typical load and construction practices and as such periodic maintenance should be anticipated. All pavement materials and construction procedures should conform to the appropriate Hernando County specifications and/or jurisdictional requirements.

In general, following the completion of the recommended clearing and grading operations, the compacted fill and natural shallow sandy soils should be acceptable for construction and support of a flexible (limerock, crushed concrete, or shell base) type pavement section or rigid (concrete) pavement section.

In proposed pavement areas, it is recommended that a minimum clearance of at least 18 inches be provided between the top of the Strata 3 and 4 clayey soils and the bottom of the base. In addition, due to the semi-confining/confining nature of the Strata 3 and 4 soils, underdrains may be required as part of the roadway design for the development.

Any fill utilized to elevate the cleared pavement areas to subgrade elevation should consist of relatively clean (maximum 12% passing #200 sieve sizes) sands uniformly compacted to a minimum depth of 12 inches to a minimum density of 95% of the modified Proctor maximum dry density. In flexible pavement areas we recommend 12 inches of Type B stabilized subgrade (LBR = 40) below the base course. Traffic should not be allowed on the subgrade as the base is placed to avoid rutting. The subgrade should be checked for soundness and be true to line and grade prior to the placement of the base course.

The choice of pavement base type will depend on final pavement grades in relation to the seasonal high groundwater levels presented in this report. If a minimum separation of 18 inches between the bottom of the base and the seasonal high groundwater level is obtained, then a limerock, shell, or crushed concrete base can be utilized. A crushed concrete base should be utilized if the separation between final grade and the seasonal high groundwater is a minimum of 12 inches and less than 18 inches. Base material elevations should not be designed for saturated conditions. If the designer wishes to have base material closer than 12 inches to the SHGWT, then an underdrain system should be utilized that will maintain the 12 inches of separation. The SHGWT should be re-established relative to a known elevation prior to setting final grades. Limerock, shell and crushed concrete base material should meet Florida Department of Transportation (FDOT) requirements including compaction to a minimum density of 98% of the modified Proctor maximum dry density and a minimum Limerock Bearing Ratio (LBR) of 100%. Crushed concrete should be graded in accordance with FDOT Standard Specification Sections. As a guideline for pavement design, we recommend that the base course be a minimum of 6 inches thick in parking areas and 8 inches thick in heavily traveled drives. Before paving, the base should be checked for soundness.

The asphaltic concrete structural course should consist of at least one and one-half (1½) inches of Type S or SP asphaltic concrete material. The asphaltic concrete should meet standard FDOT material requirements and placement procedures as outlined in the current FDOT Standard Specifications.

As an alternate to the above referenced flexible pavement design, a rigid (concrete) pavement design could be used. The concrete should have a minimum compressive strength of 4,000 psi at 28 days when tested in accordance with ASTM C-39. Based on our experience, a minimum thickness of five (5) inches should be utilized for standard duty applications and a minimum thickness of six (6) inches should be utilized for heavy-duty applications. The steel reinforcement within the concrete pavement should be designed by the project civil engineer. The subgrade soils should be compacted to a minimum density of 95% of the modified Proctor maximum dry density.

Drainage and Groundwater Concerns

Fluctuation of groundwater should be anticipated. We recommend that the Contractor determine the actual groundwater levels at the time of construction to determine potential groundwater impacts that may occur during construction. Groundwater and surface water control will be necessary for overall site development. During subgrade soil preparation, any soils below design grade could become disturbed by construction activities. If this becomes the case, the contractor may be directed by the owner's representative to remove the disturbed or pumping soils to a depth of 12 to 18 inches below design grade and backfill the area with structural fill.

Water should not be allowed to collect on prepared subgrades of the construction either during or after construction. Undercut or excavated areas should be sloped toward one corner to facilitate removal of any collected rainwater, groundwater, or surface runoff. Positive site drainage should be provided to reduce infiltration of surface water around the perimeter of the buildings and beneath the floor slabs. The grades should be sloped away from the buildings and surface drainage should be collected and discharged such that water is not permitted to infiltrate the backfill and floor slab areas of the buildings. Areas not properly drained will pool surface and groundwater and become oversaturated and not suitable for development.

Backfill

All materials to be used for fill or backfill should be evaluated and, if necessary, tested by Tierra prior to placement to determine if they are suitable for the intended use. Suitable fill materials should be placed and compacted in accordance with the artificial turn manufacturer's requirements for the respective backfill zones and be free of rubble, organics, debris and other unsuitable material.

Excavations and Temporary Side Slopes

Excavations and temporary side slopes should comply with the Occupational Safety and Health Administration's (OSHA) trench safety standards, 29 C.F.R., s. 1926.650, Subpart P, all subsequent revisions or updates of OSHA's referenced standard adopted by the Department of Labor and Employment Security and Florida's Trench Safety Act, Section 553.62, Florida Statutes.

We are providing this information solely as a service to our client. Tierra does not assume responsibility for construction site safety or the contractor's or other party's compliance with local, state, and federal safety or other regulations.

REPORT LIMITATIONS

The analyses, conclusions and recommendations contained in this report are our opinions based on the site conditions and project information described herein and further assume that the conditions observed in the exploratory borings are representative of the subsurface conditions throughout the site, i.e., the subsurface conditions elsewhere on the site are the same as those disclosed by the borings. If, during construction, subsurface conditions different from those encountered in the exploratory borings are observed or appear to be present beneath excavations, we should be advised at once so that we can review these conditions and reconsider our recommendations where necessary.

The scope of our services did not include an environmental assessment for determining the presence or absence of wetlands or hazardous or toxic materials in the soil, bedrock, groundwater, or air, on or below or around this site. Any statements in this report or on the boring logs regarding odors, colors, unusual or suspicious items or conditions are strictly for the information of our client

If there is a substantial lapse in time between the submittal of this report and the start of work at the site, or if conditions or project layout are changed due to natural causes or construction operations at or adjacent to the site, we recommend that this report be reviewed to determine the applicability of conclusions and recommendations considering the changed conditions and time lapse.

This report was prepared for the exclusive use of Costal Engineering Associates, Inc. and their client for evaluating the design of the project as it relates to the geotechnical aspects discussed herein. It should be made available to prospective contractors for information on factual data only and not as a warranty of subsurface conditions included in this report. Unanticipated soil conditions may require that additional expense be made to attain a properly constructed project. Therefore, some contingency fund is recommended to accommodate such potential extra costs.

APPENDIX

Boring Location Plan

Soil Profiles

Summary of Geotechnical Parameters

GPR Survey Plan



BORING LOCATION PLAN



LEGEND

- APPROXIMATE LOCATION OF AUGER BORING
- APPROXIMATE LOCATION OF SPT BORING

DRAWN BY:
SW

CHECKED BY:
TJ

APPROVED BY:
DRR

DATE:
JAN 2022

ENGINEER OF RECORD:
DANIEL R. RUEL, P.E.
FLORIDA LICENSE NO.:
82404



SCALE:
NOTED

PROJECT NUMBER:
6511-21-369

GEOTECHNICAL ENGINEERING SERVICES
CITIZENS CENTER FOR SUCCESS
HERNANDO COUNTY, FLORIDA

SHEET 1

SOIL PROFILES

LEGEND

SOUTHWESTERN DRAINAGE AREA

BOR # PBS-1
EASTING 511197
NORTHING 1507545
DATE 1/4/2022
DRILLER B. CRAIG

BOR # PBS-2
EASTING 511061
NORTHING 1507413
DATE 1/4/2022
DRILLER B. CRAIG

BOR # PBS-10
EASTING 511190
NORTHING 1507325
DATE 1/3/2022
DRILLER B. CRAIG

BOR # PBA-1
EASTING 511066
NORTHING 1507606
DATE 1/10/2022

BOR # PBA-2
EASTING 511179
NORTHING 1507381
DATE 1/10/2022

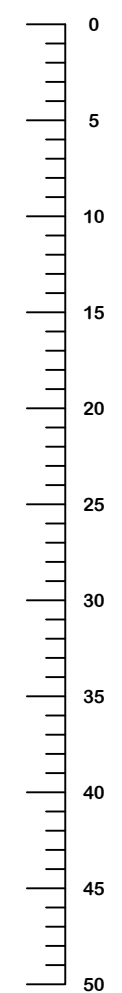
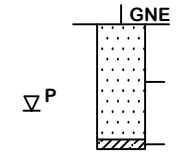
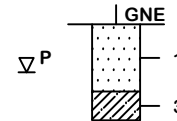
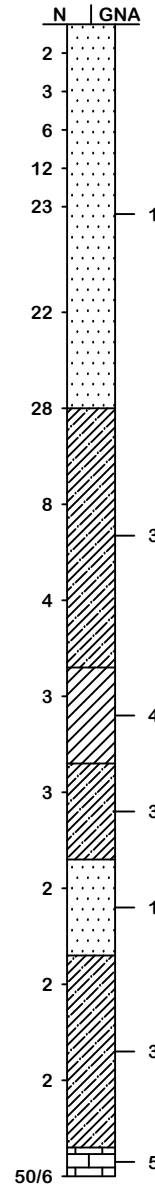
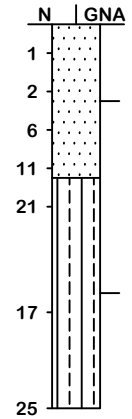
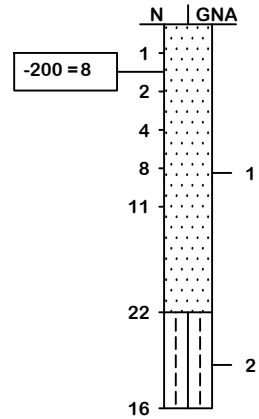

- 1 LIGHT GRAY TO BROWN SAND TO SAND WITH SILT (SP/SP-SM)
- 2 LIGHT GRAY TO BROWN SILTY SAND (SM)
- 3 LIGHT GRAY CLAYEY SAND (SC)
- 4 GRAY CLAY (CL/CH)
- 5 WEATHERED LIMESTONE

- ▽ ESTIMATED SEASONAL HIGH GROUNDWATER TABLE
- ▽^P ESTIMATED SEASONAL HIGH GROUNDWATER TABLE IS A PERCHED CONDITION
- ≥▽ ESTIMATED SEASONAL HIGH GROUNDWATER TABLE IS AT OR BELOW THE DEPTH INDICATED
- N SPT N-VALUE IN BLOWS/FOOT FOR 12 INCHES OF PENETRATION (UNLESS OTHERWISE NOTED)
- SP UNIFIED SOIL CLASSIFICATION SYSTEM (ASTM D 2488) GROUP SYMBOL AS DETERMINED BY VISUAL REVIEW AND LABORATORY TESTING ON SELECTED SAMPLES FOR CONFIRMATION OF VISUAL REVIEW.
- GNE GROUNDWATER TABLE NOT ENCOUNTERED
- GNA GROUNDWATER NOT APPARENT DUE TO DRILLING METHOD USED
- 50/4 NUMBER OF BLOWS FOR 4 INCHES OF PENETRATION
- 100 LOSS OF CIRCULATION OF DRILLING FLUID (100%)
- 200 PERCENT PASSING #200 SIEVE
- NMC NATURAL MOISTURE CONTENT (%)
- LL LIQUID LIMIT (%)
- PI PLASTICITY INDEX (%)
- NP NON PLASTIC
- EASTING EASTING COORDINATE REFERENCED TO THE FLORIDA STATE PLANE COORDINATE SYSTEM, FLORIDA WEST ZONE, N.A.D. 83 DETERMINED USING HAND-HELD GARMIN ETREX GPS EQUIPMENT WITH A REPORTED ACCURACY OF +/- 10 FEET
- NORTHING NORTHING COORDINATE REFERENCED TO THE FLORIDA STATE PLANE COORDINATE SYSTEM, FLORIDA WEST ZONE, N.A.D. 83 DETERMINED USING HAND-HELD GARMIN ETREX GPS EQUIPMENT WITH A REPORTED ACCURACY OF +/- 10 FEET

AUTOMATIC HAMMER	
GRANULAR MATERIALS- RELATIVE DENSITY	SPT (BLOWS/FT.)
VERY LOOSE	LESS THAN 3
LOOSE	3 TO 8
MEDIUM	8 TO 24
DENSE	24 TO 40
VERY DENSE	GREATER THAN 40
SILTS AND CLAYS CONSISTENCY	SPT (BLOWS/FT.)
VERY SOFT	LESS THAN 1
SOFT	1 TO 3
FIRM	3 TO 6
STIFF	6 TO 12
VERY STIFF	12 TO 24
HARD	GREATER THAN 24

DRAWN BY: SW
CHECKED BY: TJ

APPROVED BY: DRR
DATE: JAN 2022

ENGINEER OF RECORD: DANIEL R. RUEL, P.E.
FLORIDA LICENSE NO.: 82404



SCALE: NOTED

PROJECT NUMBER: 6511-21-369

GEOTECHNICAL ENGINEERING SERVICES
CITIZENS CENTER FOR SUCCESS
HERNANDO COUNTY, FLORIDA

SHEET 2

SOIL PROFILES

LEGEND

NORTHWESTERN DRAINAGE AREA

NORTHEASTERN DRAINAGE AREA

BOR # PBS-3
EASTING 511051
NORTHING 1507780
DATE 1/4/2022
DRILLER B. CRAIG

BOR # PBA-3
EASTING 510910
NORTHING 1507756
DATE 1/5/2022

BOR # PBA-4
EASTING 511163
NORTHING 1507752
DATE 1/5/2022

BOR # PBS-11
EASTING 510926
NORTHING 1507764
DATE 1/4/2022
DRILLER B. CRAIG

BOR # PBS-4
EASTING 512702
NORTHING 1507689
DATE 1/5/2022
DRILLER B. CRAIG

BOR # PBS-5
EASTING 512566
NORTHING 1507530
DATE 1/5/2022
DRILLER B. CRAIG

DEPTH IN FEET

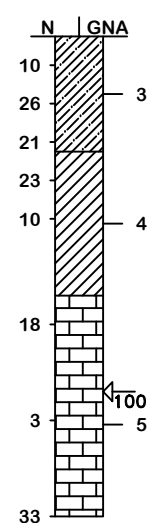
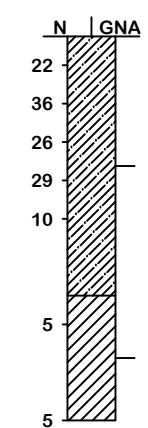
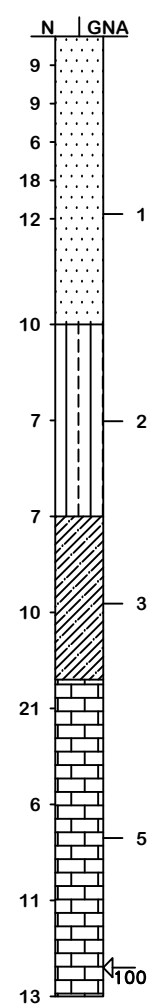
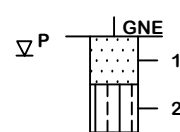
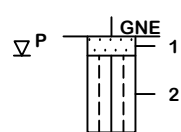
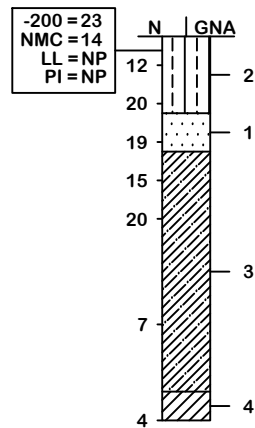

DEPTH IN FEET

- 1 LIGHT GRAY TO BROWN SAND TO SAND WITH SILT (SP/SP-SM)
- 2 LIGHT GRAY TO BROWN SILTY SAND (SM)
- 3 LIGHT GRAY CLAYEY SAND (SC)
- 4 GRAY CLAY (CL/CH)
- 5 WEATHERED LIMESTONE
- ▽ ESTIMATED SEASONAL HIGH GROUNDWATER TABLE
- ▽ P ESTIMATED SEASONAL HIGH GROUNDWATER TABLE IS A PERCHED CONDITION
- ≥ ▽ ESTIMATED SEASONAL HIGH GROUNDWATER TABLE IS AT OR BELOW THE DEPTH INDICATED
- N SPT N-VALUE IN BLOWS/FOOT FOR 12 INCHES OF PENETRATION (UNLESS OTHERWISE NOTED)
- SP UNIFIED SOIL CLASSIFICATION SYSTEM (ASTM D 2488) GROUP SYMBOL AS DETERMINED BY VISUAL REVIEW AND LABORATORY TESTING ON SELECTED SAMPLES FOR CONFIRMATION OF VISUAL REVIEW.
- GNE GROUNDWATER TABLE NOT ENCOUNTERED
- GNA GROUNDWATER NOT APPARENT DUE TO DRILLING METHOD USED
- 50/4 NUMBER OF BLOWS FOR 4 INCHES OF PENETRATION
- ↳100 LOSS OF CIRCULATION OF DRILLING FLUID (100%)
- 200 PERCENT PASSING #200 SIEVE
- NMC NATURAL MOISTURE CONTENT (%)
- LL LIQUID LIMIT (%)
- PI PLASTICITY INDEX (%)
- NP NON PLASTIC
- EASTING EASTING COORDINATE REFERENCED TO THE FLORIDA STATE PLANE COORDINATE SYSTEM, FLORIDA WEST ZONE, N.A.D. 83 DETERMINED USING HAND-HELD GARMIN ETREX GPS EQUIPMENT WITH A REPORTED ACCURACY OF +/- 10 FEET
- NORTHING NORTHING COORDINATE REFERENCED TO THE FLORIDA STATE PLANE COORDINATE SYSTEM, FLORIDA WEST ZONE, N.A.D. 83 DETERMINED USING HAND-HELD GARMIN ETREX GPS EQUIPMENT WITH A REPORTED ACCURACY OF +/- 10 FEET

AUTOMATIC HAMMER	
GRANULAR MATERIALS- RELATIVE DENSITY	SPT (BLOWS/FT.)
VERY LOOSE	LESS THAN 3
LOOSE	3 TO 8
MEDIUM	8 TO 24
DENSE	24 TO 40
VERY DENSE	GREATER THAN 40
SILTS AND CLAYS CONSISTENCY	SPT (BLOWS/FT.)
VERY SOFT	LESS THAN 1
SOFT	1 TO 3
FIRM	3 TO 6
STIFF	6 TO 12
VERY STIFF	12 TO 24
HARD	GREATER THAN 24

SOIL PROFILES

LEGEND

NORTHWESTERN DRAINAGE AREA

BOR # PBS-6
EASTING 512954
NORTHING 1507353
DATE 1/5/2022
DRILLER B. CRAIG

BOR # PBA-5
EASTING 512535
NORTHING 1507697
DATE 1/4/2022

BOR # PBA-6
EASTING 512820
NORTHING 1507690
DATE 1/4/2022

BOR # PBA-7
EASTING 513080
NORTHING 1507682
DATE 1/4/2022

BOR # PBA-8
EASTING 512677
NORTHING 1507577
DATE 1/4/2022

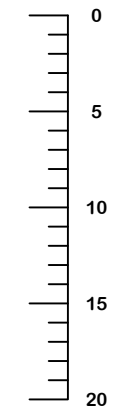
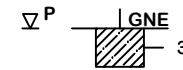
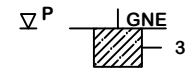
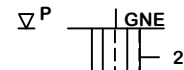
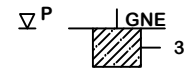
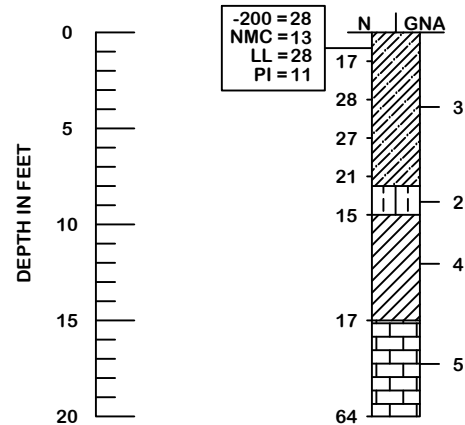

- 1 LIGHT GRAY TO BROWN SAND TO SAND WITH SILT (SP/SP-SM)
- 2 LIGHT GRAY TO BROWN SILTY SAND (SM)
- 3 LIGHT GRAY CLAYEY SAND (SC)
- 4 GRAY CLAY (CL/CH)
- 5 WEATHERED LIMESTONE

- ∇^P ESTIMATED SEASONAL HIGH GROUNDWATER TABLE
- ∇^P ESTIMATED SEASONAL HIGH GROUNDWATER TABLE IS A PERCHED CONDITION
- $\geq \nabla$ ESTIMATED SEASONAL HIGH GROUNDWATER TABLE IS AT OR BELOW THE DEPTH INDICATED
- N SPT N-VALUE IN BLOWS/FOOT FOR 12 INCHES OF PENETRATION (UNLESS OTHERWISE NOTED)
- SP UNIFIED SOIL CLASSIFICATION SYSTEM (ASTM D 2488) GROUP SYMBOL AS DETERMINED BY VISUAL REVIEW AND LABORATORY TESTING ON SELECTED SAMPLES FOR CONFIRMATION OF VISUAL REVIEW.
- GNE GROUNDWATER TABLE NOT ENCOUNTERED
- GNA GROUNDWATER NOT APPARENT DUE TO DRILLING METHOD USED
- 50/4 NUMBER OF BLOWS FOR 4 INCHES OF PENETRATION
- ∇_{100} LOSS OF CIRCULATION OF DRILLING FLUID (100%)
- 200 PERCENT PASSING #200 SIEVE
- NMC NATURAL MOISTURE CONTENT (%)
- LL LIQUID LIMIT (%)
- PI PLASTICITY INDEX (%)
- NP NON PLASTIC
- EASTING EASTING COORDINATE REFERENCED TO THE FLORIDA STATE PLANE COORDINATE SYSTEM, FLORIDA WEST ZONE, N.A.D. 83 DETERMINED USING HAND-HELD GARMIN ETREX GPS EQUIPMENT WITH A REPORTED ACCURACY OF +/- 10 FEET
- NORTHING NORTHING COORDINATE REFERENCED TO THE FLORIDA STATE PLANE COORDINATE SYSTEM, FLORIDA WEST ZONE, N.A.D. 83 DETERMINED USING HAND-HELD GARMIN ETREX GPS EQUIPMENT WITH A REPORTED ACCURACY OF +/- 10 FEET

NORTHWESTERN DRAINAGE AREA

BOR # PBA-9
EASTING 512930
NORTHING 1507560
DATE 1/4/2022

BOR # PBA-10
EASTING 513156
NORTHING 1507538
DATE 1/4/2022

BOR # PBA-11
EASTING 512554
NORTHING 1507419
DATE 1/4/2022

BOR # PBA-12
EASTING 512829
NORTHING 1507450
DATE 1/4/2022

BOR # PBA-13
EASTING 513030
NORTHING 1507390
DATE 1/4/2022

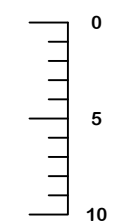
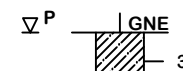
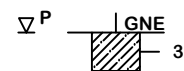

AUTOMATIC HAMMER	
GRANULAR MATERIALS- RELATIVE DENSITY	SPT (BLOWS/FT.)
VERY LOOSE	LESS THAN 3
LOOSE	3 TO 8
MEDIUM	8 TO 24
DENSE	24 TO 40
VERY DENSE	GREATER THAN 40
SILTS AND CLAYS CONSISTENCY	SPT (BLOWS/FT.)
VERY SOFT	LESS THAN 1
SOFT	1 TO 3
FIRM	3 TO 6
STIFF	6 TO 12
VERY STIFF	12 TO 24
HARD	GREATER THAN 24

DRAWN BY:
SW

CHECKED BY:
TJ

APPROVED BY:
DRR

DATE:
JAN 2022

ENGINEER OF RECORD:
DANIEL R. RUEL, P.E.
FLORIDA LICENSE NO.:
82404

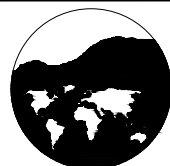

TIERRA
7351 Temple Terrace Highway
Tampa, Florida 33637
Phone: 813-989-1354 Fax: 813-989-1355

SCALE:
NOTED

PROJECT NUMBER:
6511-21-369

GEOTECHNICAL ENGINEERING SERVICES
CITIZENS CENTER FOR SUCCESS
HERNANDO COUNTY, FLORIDA

SHEET 4

SOIL PROFILES

LEGEND

SOUTHEASTERN DRAINAGE AREA

BOR # PBS-7
EASTING 512550
NORTHING 1507025
DATE 1/5/2022
DRILLER B. CRAIG

BOR # PBS-8
EASTING 512862
NORTHING 1507011
DATE 1/5/2022
DRILLER B. CRAIG

BOR # PBS-9
EASTING 512739
NORTHING 1507114
DATE 1/3/2022
DRILLER B. CRAIG

BOR # PBA-14
EASTING 512490
NORTHING 1507152
DATE 1/5/2022

BOR # PBA-15
EASTING 512688
NORTHING 1507056
DATE 1/5/2022

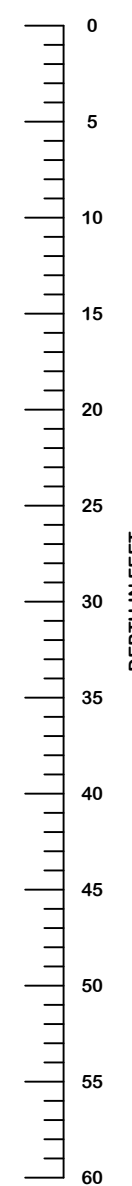
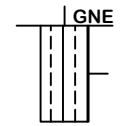
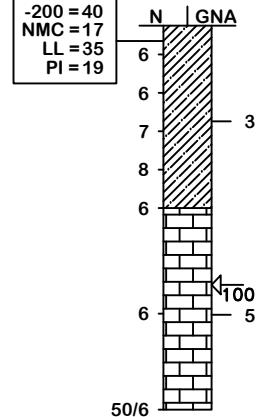
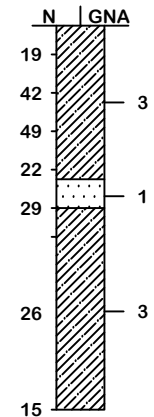
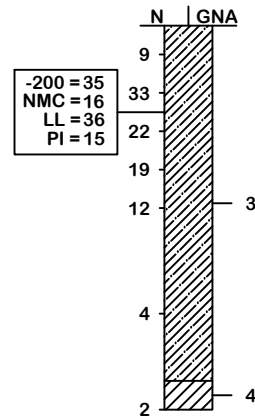
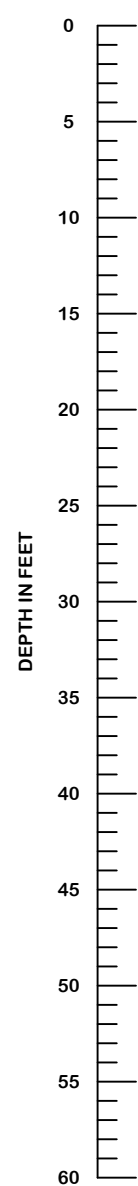

- 1 LIGHT GRAY TO BROWN SAND TO SAND WITH SILT (SP/SP-SM)
- 2 LIGHT GRAY TO BROWN SILTY SAND (SM)
- 3 LIGHT GRAY CLAYEY SAND (SC)
- 4 GRAY CLAY (CL/CH)
- 5 WEATHERED LIMESTONE

- ▽ ESTIMATED SEASONAL HIGH GROUNDWATER TABLE
- ▽^P ESTIMATED SEASONAL HIGH GROUNDWATER TABLE IS A PERCHED CONDITION
- ≥▽ ESTIMATED SEASONAL HIGH GROUNDWATER TABLE IS AT OR BELOW THE DEPTH INDICATED
- N SPT N-VALUE IN BLOWS/FOOT FOR 12 INCHES OF PENETRATION (UNLESS OTHERWISE NOTED)
- SP UNIFIED SOIL CLASSIFICATION SYSTEM (ASTM D 2488) GROUP SYMBOL AS DETERMINED BY VISUAL REVIEW AND LABORATORY TESTING ON SELECTED SAMPLES FOR CONFIRMATION OF VISUAL REVIEW.
- GNE GROUNDWATER TABLE NOT ENCOUNTERED
- GNA GROUNDWATER NOT APPARENT DUE TO DRILLING METHOD USED
- 50/4 NUMBER OF BLOWS FOR 4 INCHES OF PENETRATION
- ↙100 LOSS OF CIRCULATION OF DRILLING FLUID (100%)
- 200 PERCENT PASSING #200 SIEVE
- NMC NATURAL MOISTURE CONTENT (%)
- LL LIQUID LIMIT (%)
- PI PLASTICITY INDEX (%)
- NP NON PLASTIC
- EASTING EASTING COORDINATE REFERENCED TO THE FLORIDA STATE PLANE COORDINATE SYSTEM, FLORIDA WEST ZONE, N.A.D. 83 DETERMINED USING HAND-HELD GARMIN ETREX GPS EQUIPMENT WITH A REPORTED ACCURACY OF +/- 10 FEET
- NORTHING NORTHING COORDINATE REFERENCED TO THE FLORIDA STATE PLANE COORDINATE SYSTEM, FLORIDA WEST ZONE, N.A.D. 83 DETERMINED USING HAND-HELD GARMIN ETREX GPS EQUIPMENT WITH A REPORTED ACCURACY OF +/- 10 FEET

AUTOMATIC HAMMER	
GRANULAR MATERIALS- RELATIVE DENSITY	SPT (BLOWS/FT.)
VERY LOOSE	LESS THAN 3
LOOSE	3 TO 8
MEDIUM	8 TO 24
DENSE	24 TO 40
VERY DENSE	GREATER THAN 40
SILTS AND CLAYS CONSISTENCY	SPT (BLOWS/FT.)
VERY SOFT	LESS THAN 1
SOFT	1 TO 3
FIRM	3 TO 6
STIFF	6 TO 12
VERY STIFF	12 TO 24
HARD	GREATER THAN 24

SOIL PROFILES

LEGEND

SOUTHEASTERN DRAINAGE AREA

ROADWAY

BOR # PBA-16
EASTING 512904
NORTHING 1507093
DATE 1/5/2022

BOR # PBA-17
EASTING 512509
NORTHING 1506887
DATE 1/5/2022

BOR # PBA-18
EASTING 512794
NORTHING 1506889
DATE 1/5/2022

BOR # HA-1
EASTING 511492
NORTHING 1507223
DATE 1/4/2022

BOR # HA-2
EASTING 511863
NORTHING 1507206
DATE 1/4/2022

DEPTH IN FEET

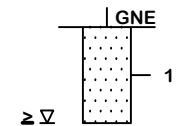
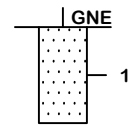
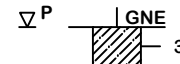
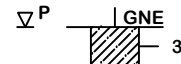

DEPTH IN FEET

ROADWAY

BOR # HA-3
EASTING 512280
NORTHING 1507203
DATE 1/4/2022

BOR # HA-4
EASTING 512026
NORTHING 1507342
DATE 1/4/2022

BOR # HA-5
EASTING 512018
NORTHING 1507526
DATE 1/4/2022

BOR # HA-6
EASTING 512003
NORTHING 1507693
DATE 1/4/2022

DEPTH IN FEET

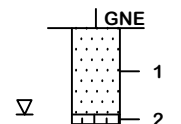
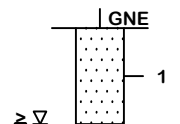
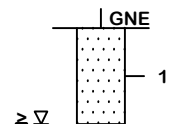
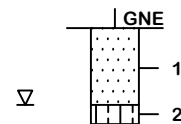

DEPTH IN FEET

- 1 LIGHT GRAY TO BROWN SAND TO SAND WITH SILT (SP/SP-SM)
- 2 LIGHT GRAY TO BROWN SILTY SAND (SM)
- 3 LIGHT GRAY CLAYEY SAND (SC)
- 4 GRAY CLAY (CL/CH)
- 5 WEATHERED LIMESTONE
- ∇ ESTIMATED SEASONAL HIGH GROUNDWATER TABLE
- ∇^P ESTIMATED SEASONAL HIGH GROUNDWATER TABLE IS A PERCHED CONDITION
- ≥∇ ESTIMATED SEASONAL HIGH GROUNDWATER TABLE IS AT OR BELOW THE DEPTH INDICATED
- N SPT N-VALUE IN BLOWS/FOOT FOR 12 INCHES OF PENETRATION (UNLESS OTHERWISE NOTED)
- SP UNIFIED SOIL CLASSIFICATION SYSTEM (ASTM D 2488) GROUP SYMBOL AS DETERMINED BY VISUAL REVIEW AND LABORATORY TESTING ON SELECTED SAMPLES FOR CONFIRMATION OF VISUAL REVIEW.
- GNE GROUNDWATER TABLE NOT ENCOUNTERED
- GNA GROUNDWATER NOT APPARENT DUE TO DRILLING METHOD USED
- 50/4 NUMBER OF BLOWS FOR 4 INCHES OF PENETRATION
- 100 LOSS OF CIRCULATION OF DRILLING FLUID (100%)
- 200 PERCENT PASSING #200 SIEVE
- NMC NATURAL MOISTURE CONTENT (%)
- LL LIQUID LIMIT (%)
- PI PLASTICITY INDEX (%)
- NP NON PLASTIC
- EASTING EASTING COORDINATE REFERENCED TO THE FLORIDA STATE PLANE COORDINATE SYSTEM, FLORIDA WEST ZONE, N.A.D. 83 DETERMINED USING HAND-HELD GARMIN ETREX GPS EQUIPMENT WITH A REPORTED ACCURACY OF +/- 10 FEET
- NORTHING NORTHING COORDINATE REFERENCED TO THE FLORIDA STATE PLANE COORDINATE SYSTEM, FLORIDA WEST ZONE, N.A.D. 83 DETERMINED USING HAND-HELD GARMIN ETREX GPS EQUIPMENT WITH A REPORTED ACCURACY OF +/- 10 FEET

AUTOMATIC HAMMER	
GRANULAR MATERIALS- RELATIVE DENSITY	SPT (BLOWS/FT.)
VERY LOOSE	LESS THAN 3
LOOSE	3 TO 8
MEDIUM	8 TO 24
DENSE	24 TO 40
VERY DENSE	GREATER THAN 40
SILTS AND CLAYS CONSISTENCY	SPT (BLOWS/FT.)
VERY SOFT	LESS THAN 1
SOFT	1 TO 3
FIRM	3 TO 6
STIFF	6 TO 12
VERY STIFF	12 TO 24
HARD	GREATER THAN 24

DRAWN BY:
SW

APPROVED BY:
DRR

ENGINEER OF RECORD:
DANIEL R. RUEL, P.E.
FLORIDA LICENSE NO.:
82404



TIERRA
7351 Temple Terrace Highway
Tampa, Florida 33637
Phone: 813-989-1354 Fax: 813-989-1355

SCALE:
NOTED

PROJECT NUMBER:
6511-21-369

GEOTECHNICAL ENGINEERING SERVICES
CITIZENS CENTER FOR SUCCESS
HERNANDO COUNTY, FLORIDA

SHEET 6

**Summary of Geotechnical Parameters
Citizens Center for Success
Hernando County, Florida
Tierra Project No.: 6511-21-369**

Boring Name	Boring/Test Locations ⁽¹⁾ (FL West NAD 83)		Date Recorded	Estimated SHGWT Depth ⁽²⁾ (feet)	Type of Test Completed	Permeability Test Results			Depth to Confining Layer (feet)
	Easting	Northing				Approximate Test Depth (feet)	Stratum Tested	In-Situ Hydraulic Conductivity, K ⁽³⁾ (feet/day)	
Southwestern Drairage Area									
PBA-1	511066	1507606	1/10/2022	2.5 ^P	Constant Head	2.5	1	40	3.5
PBA-2	511179	1507381	1/10/2022	4.5 ^P	Constant Head	4.5	1	40	6.0
PBS-1	511197	1507545	1/4/2022	N/D		N/A			20.0
PBS-2	511061	1507413	1/4/2022	N/D		N/A			20.0
PBS-10	511173	1507299	1/3/2022	N/D		N/A			20.0
Northwestern Drairage Area									
PBA-3	510910	1507756	1/5/2022	1.0 ^P	Falling Head	0.8	2	3	>4.5
PBA-4	511163	1507752	1/5/2022	1.0 ^P	Constant Head	1.5	1	20	>4.5
PBS-3	511051	1507780	1/4/2022	N/D		N/A			6.0
PBS-11	510956	1507770	1/4/2022	N/D		N/A			20.0
Northeastern Drairage Area									
PBA-5	512535	1507697	1/4/2022	At or Above Grade ^P	Falling Head	2.0	1	0.1	0.0
PBA-6	512820	1507690	1/4/2022	At or Above Grade ^P		N/A			>3.0
PBA-7	513080	1507682	1/4/2022	At or Above Grade ^P		N/A			0.0
PBA-8	512677	1507577	1/4/2022	At or Above Grade ^P		N/A			0.0
PBA-9	512930	1507560	1/4/2022	At or Above Grade ^P	Falling Head	2.0	3	0.2	>2.0
PBA-10	513156	1507538	1/4/2022	N/D		N/A			0.0
PBA-11	512554	1507419	1/4/2022	At or Above Grade ^P	Falling Head	2.0	2	0.8	0.0
PBA-12	512829	1507450	1/4/2022	At or Above Grade ^P		N/A			0.0
PBA-13	513030	1507390	1/4/2022	At or Above Grade ^P		N/A			0.0
PBS-4	512702	1507689	1/5/2022	N/D		N/A			0.0
PBS-5	512566	1507530	1/5/2022	N/D		N/A			0.0
PBS-6	512954	1507353	1/5/2022	N/D		N/A			0.0
Southeastern Drairage Area									
PBA-14	512490	1507152	1/5/2022	N/D		N/A			≥5.0
PBA-15	512688	1507056	1/5/2022	At or Above Grade ^P	Falling Head	2.0	3	0.1	0.0
PBA-16	512904	1507093	1/5/2022	At or Above Grade ^P		N/A			0.0
PBA-17	512509	1506887	1/5/2022	At or Above Grade ^P	Falling Head	2.0	3	0.1	0.0
PBA-18	512794	1506889	1/5/2022	At or Above Grade ^P	Falling Head	2.0	2	0.1	>2.0
PBS-7	512550	1507025	1/5/2022	N/D		N/A			0.0
PBS-8	512862	1507011	1/5/2022	N/D		N/A			0.0
PBS-9	512717	1507115	1/3/2022	N/D		N/A			0.0

⁽¹⁾ The boring/test locations were determined in the field using hand-held, non-survey grade Garmin eTrex® Global Positioning System (GPS) equipment with a manufacturer's reported accuracy of ± 10 feet.

The boring/test locations should be considered approximate.

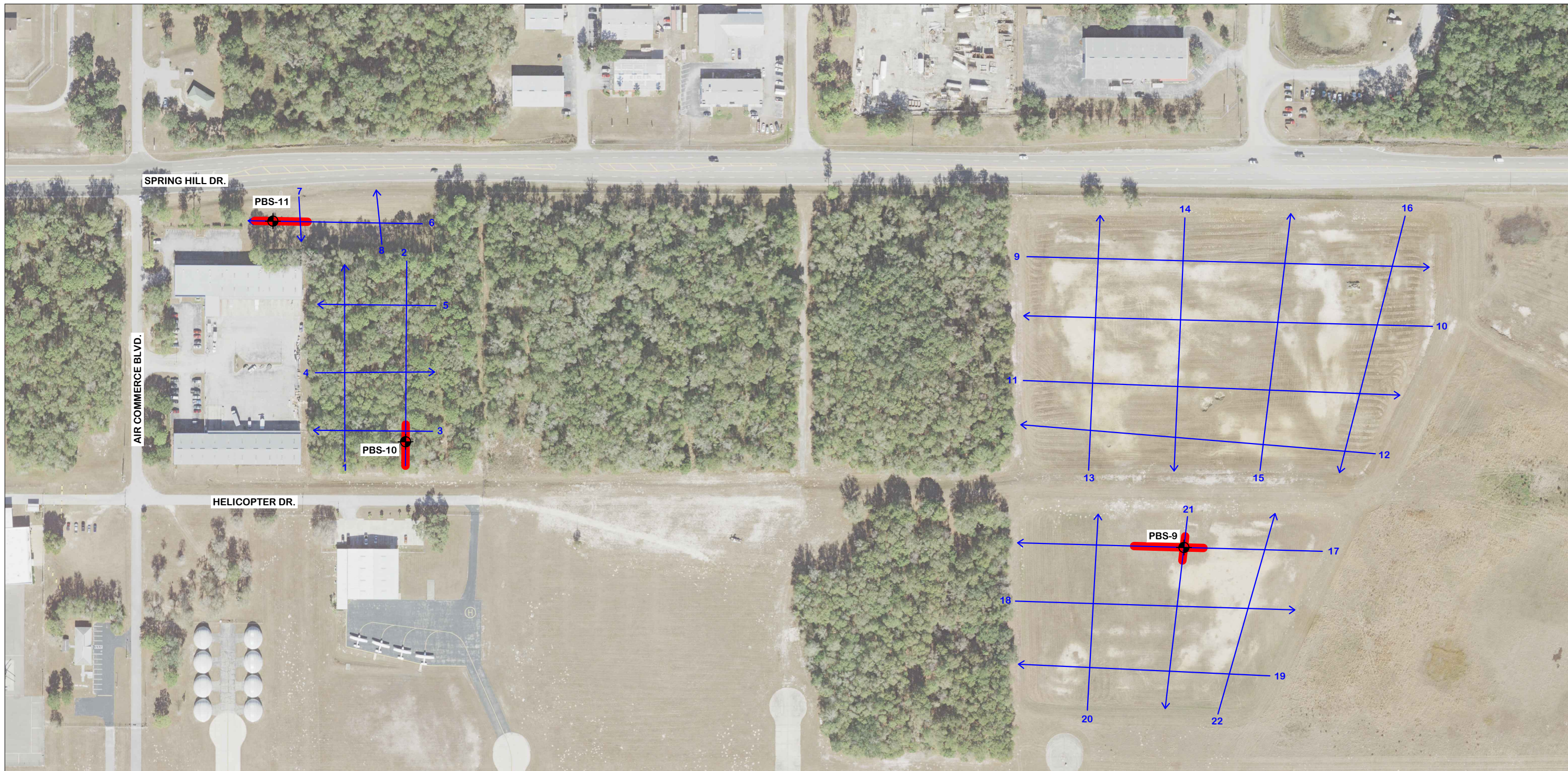

⁽²⁾ Seasonal High Groundwater Table (SHGWT) estimated based on soil stratigraphy, measured groundwater levels from the borings, the Hernando County, Florida USDA soil survey information and past experience with similar soil conditions. SHGWT is in perched conditions.

⁽³⁾ The hydraulic conductivity values provided are measured in-situ field rates. These values are not factored. The drainage engineer should apply an appropriate factor of safety, as applicable.



GPR SURVEY PLAN



 APPROXIMATE LOCATION OF GPR ANOMALY
 PATH OF GPR TRANSECT LINES WITH DESIGNATION NUMBER (250 MHz ANTENNA)

DRAWN BY:
SW

CHECKED BY:
TJ

APPROVED BY:
DRR

DATE:
JAN 2022

ENGINEER OF RECORD:
DANIEL R. RUEL, P.E.
FLORIDA LICENSE NO.:
82404

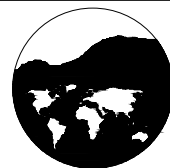

TIERRA
7351 Temple Terrace Highway
Tampa, Florida 33637
Phone: 813-989-1354 Fax: 813-989-1355

SCALE:
NOTED

PROJECT NUMBER:
6511-21-369

GEOTECHNICAL ENGINEERING SERVICES
CITIZENS CENTER FOR SUCCESS
HERNANDO COUNTY, FLORIDA

SHEET 7

2. SOLICITATION-OFFER-AWARD

ISSUED BY:

BOARD OF COUNTY COMMISSIONERS

HERNANDO COUNTY, FLORIDA

John Allocco, Chairman

Elizabeth Narverud, Vice Chairman

Steve Champion, Second Vice Chairman

Jerry Campbell

Brian Hawkins

SUBMIT BID OFFER TO:

HERNANDO COUNTY

PROCUREMENT DEPARTMENT

via Hernando County's [eProcurement Portal](#)

Toni Brady

Chief Procurement Officer

3. SOLICITATION

SEALED OFFERS, FOR FURNISHING THE SERVICES, SUPPLIES OR EQUIPMENT DESCRIBED HEREIN WILL BE RECEIVED BY THE OFFICE OF PROCUREMENT DEPARTMENT, VIA THE COUNTY'S [eProcurement Portal](#) UNTIL 10:00 am, LOCAL TIME ON Monday, April 10, 2023. NO BID OFFERS WILL BE ACCEPTED AFTER THE ABOVE STIPULATED DATE AND TIME. THIS IS AN ADVERTISED SOLICITATION AND THE RESPONDING BIDDERS WILL BE PUBLICLY READ IN THE PROCUREMENT DEPARTMENT CONFERENCE ROOM AT 10:00 am ON Monday, April 10, 2023. PURSUANT TO FS 119.071 (current version) SEALED BIDS, PROPOSALS, OR REPLIES RECEIVED BY AN AGENCY PURSUANT TO A COMPETITIVE SOLICITATION ARE EXEMPT FROM FINAL INSPECTION UNTIL SUCH TIME AS THE AGENCY PROVIDES NOTICE OF AN INTENDED DECISION OR UNTIL THIRTY (30) DAYS AFTER OPENING THE BIDS, PROPOSALS, OR FINAL REPLIES, WHICHEVER IS EARLIER.

4. OFFER

THE UNDERSIGNED, BEING DULY AUTHORIZED TO SUBMIT THIS BID ON BEHALF OF THE BIDDER, AGREES THAT IF THIS OFFER IS ACCEPTED WITHIN ONE HUNDRED TWENTY (120) DAYS FROM THE BID OPENING DATE, TO FURNISH TO HERNANDO COUNTY ANY AND ALL ITEMS FOR WHICH PRICES ARE OFFERED IN THIS BID SOLICITATION AT THE PRICE(S) SO OFFERED, DELIVERED AT DESIGNATED POINT(S), WITHIN THE TIME PERIOD SPECIFIED, AND AT THE TERMS AND CONDITIONS SO STIPULATED IN THE SOLICITATION FOR BIDS.

5. AWARD

Upon Award please SUBMIT INVOICES TO:

Hernando County

Administration

15470 Flight Path Drive, Brooksville, FL 34604

6. PROJECT BID SPECIFICATIONS

6.1. ADVERTISEMENT OF BID

INVITATION TO BID

NOTICE IS HEREBY GIVEN that the Board of County Commissions of Hernando County, Florida, is accepting Bids for:

CONSTRUCTION CONTRACT ITB NO. SOLICITATION # 23-CG0215/JG

FOR

Dr. Dennis Wilfong Center for Success/Infrastructure - Rebid

Hernando County Board of County Commissioners is soliciting General Contractors or Underground Utility Contractors and Excavating Contractors, Electrical Contractors that are active in Infrastructure construction including but not limited to: drainage improvements and retention ponds, access roadway from Spring Hill Drive to Helicopter Drive, gopher tortoise relocation and as described in the details, plans and specifications.

Offers for furnishing the above will be received and accepted up to 10:00 a.m. (local time), Monday, April 10, 2023, via Hernando County Procurement Department's [eProcurement Portal](#). Only electronic submittals shall be accepted by the County.

The Board of County Commissioners of Hernando County, Florida reserves the right to accept or reject any or all bids and waive informalities and minor irregularities in offers received in accordance with the bid documents and the Hernando County Procurement Ordinance.

Interested firms may secure the bid documents and plans and drawings and all other pertinent information by visiting the County's eProcurement Portal. For additional project information, please visit the Hernando County Board of County Commissioners Procurement Department at www.hernandocounty.us, or by submitting a question via the Q&A Tab in the County's [eProcurement Portal](#).

Bid offers shall be accompanied by either a Bid Bond, Certified Check, Cashier's Check, or Official Bank Check in the dollar amount representing not less than five percent (5%) of the total amount bid as a guarantee to enter into a contract and furnish a contract performance and payment bond in the amount

of one hundred percent (100%) of the total bid price within fifteen (15) calendar days from the date of notification of the award.

Exparte Communication: Please note that to ensure the proper and fair evaluation of a submittal, the County prohibits exparte communication (i.e., unsolicited) initiated by the Respondent to the County official or employee evaluating or considering the submittals prior to the time a decision has been made. Communication between Respondent and the County will be initiated by the appropriate County official or employee in order to obtain information or clarification needed to develop a proper and accurate evaluation of the submittal. Exparte communication may be grounds for disqualifying the offending Respondent from consideration or award of the solicitation or any future solicitation.

Procurement Department will post addenda on [eProcurement Portal](#) to all questions in accordance with the Solicitation Instructions. It is the responsibility of prospective Bidders to visit the County's portal to ensure that they are aware of all Addenda issued relative to this Solicitation.

Pursuant to Florida Statutes 119.071 (current version) sealed bids, proposals or replies received by an agency pursuant to a competitive Solicitation are exempt from inspection until such time as the agency provides notice of an intended decision or until thirty (30) days after opening the bids, proposals, or final replies whichever is earlier.

BOARD OF COUNTY COMMISSIONERS

HERNANDO COUNTY

TONI BRADY

CHIEF PROCUREMENT OFFICER, HERNANDO COUNTY

NOTICE TO BIDDERS

To ensure that your bid is responsive, you are urged to request clarification or guidance on any issues involving this Solicitation before submission of your response. Your method of contact for this solicitation is the Q&A Tab in the County's [eProcurement Portal](#).

6.2. [MANDATORY Pre-Bid Conference](#)

MANDATORY Pre-Bid Conference will be held Wednesday, March 15, 2023, at 10:00 a.m., at the 15470 Flight Path Drive, Brooksville, FL 34604. Representatives of Owner will be present to discuss the project. Bidders are recommended to attend and participate in the conference. **THIS CONFERENCE WILL BE HELD ONLY ONCE AND FAILURE TO ATTEND AND SIGN IN SHALL DISQUALIFY ANY BIDDER NOT ATTENDING FROM SUBMITTING A BID. ATTENDEES MUST BE PRESENT AT THE START OF THE PRE-BID CONFERENCE. ARRIVAL AFTER THE START OF THE PRE-BID CONFERENCE SHALL BE CAUSE FOR DISQUALIFICATION.**

7. SOLICITATION INSTRUCTIONS

7.1. DEFINITION OF TERMS

DEFINITION OF TERMS Where the following terms, or their pronouns, occur herein, the intent and meaning shall be as follows:

- A. **ADDENDA:** Written or graphic instruments issued prior to the opening of bids which clarify, correct, or change the bidding requirements or the proposed Contract Documents.
- B. **AGENCY:** the Federal or State agency named as such in the Agreement. This project is financed in whole or in part through State of Florida, Department of Economic Opportunity and the term Agency, as used herein, shall refer to DEO.
- C. **AGREEMENT:** The written instrument which is evidence of the Agreement between Owner and Vendor/Contractor covering the work.
- D. **APPLICATION FOR PAYMENT:** The form acceptable to Engineer which is to be used by Vendor/Contractor during the course of the work in requesting progress or final payments and which is to be accompanied by such supporting documentation as is required by the Contract Documents.
- E. **BID:** The offer or proposal of a Bidder submitted on the prescribed form setting forth the prices for the work to be performed.
- F. **BID BOND/GUARANTEE:** The certified check or surety bond furnished by the Bidder with his bid as evidence of good faith.
- G. **BID DOCUMENTS:** The bidding requirements and the proposed Contract Documents, including all addenda.
- H. **BIDDER:** The term “Bidder” used herein refers to the dealer/manufacturer or business organization submitting a bid to the County in response to this Solicitation.
- I. **CHANGE ORDER:** A document recommended by Engineer which is signed by Vendor/Contractor and Owner and Agency and authorizes an addition, deletion, or revision in the work or an adjustment in the contract price or the contract times, issued on or after the Effective Date of the Agreement.
- J. **CONSTRUCTION ADMINISTRATOR:** Erik van de Boogaard, shall act as the “Construction Administrator” for the work relative to the acceptance and approval of Applications for Payment pursuant to the provisions of the Florida Prompt Payment Act, Part VII, Ch. 218.735, F.S (current version).
- K. **CONTRACT:** The Agreement executed by the Owner and Vendor/Contractor for the performance of work and the other documents (plans, specifications, notice to Bidders,

proposal, surety bonds, addenda and other incorporated or referenced documents) whether attached thereto or not.

- L. **CONTRACT PRICE:** The moneys payable by Owner to Vendor/Contractor for completion of the work in accordance with the Contract Documents as stated in the Agreement.
- M. **CONTRACT TIMES:** The number of days within which, or the dates by which, the work is to be substantially completed and ready for final payment as set forth in the Agreement. The contract times will commence on the date indicated in the Notice to Proceed.
- N. **CONTRACT WORK:** Any and all obligations, duties and responsibilities necessary to the successful completion of the project assigned to or undertaken by the Vendor/Contractor under the Contract Documents, including the furnishing of all labor, materials, equipment, and other incidentals.
- O. **CONTRACTOR:** The individual or entity with whom the County has entered into the Agreement.
- P. **COUNTY:** The Board of County Commissioners, Hernando County, or its duly authorized representative.
- Q. **ENGINEER:** Under Contract to the Owner, the Engineer in the administration of this Contract and any references to the Engineer or the Professional shall be deemed to mean Coastal Engineering Associates, Inc., for the plans and specifications referenced in these contract documents. Engineer may delegate or designate certain duties to be performed by other qualified professionals.
- R. **FDEP:** Florida Department of Environmental Protection
- S. **FDOT:** Florida Department of Transportation.
- T. **FIELD ORDER:** A written order issued by Engineer which requires minor changes in the work but which does not involve a change in the contract price or the contract times.
- U. **ISSUING OFFICE:** The office from which the bid documents are to be issued and where the bidding procedures are to be administered. Specifically - Hernando County, Procurement Department, 15470 Flight Path Drive, Brooksville, Florida 34604.
- V. **MUTCD:** Manual on Uniform Traffic Control Devices <https://mutcd.fhwa.dot.gov>
- W. **NATIONAL POLLUTANT DISCHARGE ELIMINATION SYSTEM:** NPDES
- X. **NOTICE-WRITTEN:** Notice shall be served upon the Vendor/Contractor either personally or by leaving the said notice at his residence or with his Agent in charge of the work, or addressed to the Vendor/Contractor at the residence or place of business given in the bid and deposited in a postpaid wrapper in any post box regularly maintained by the United States Post Office.

- Y. **NOTICE OF AWARD:** The written notice by Owner to the successful Bidder stating that upon timely compliance by the successful Bidder with the conditions precedent listed therein, Owner will sign and deliver the Agreement.
- Z. **NOTICE OF INTENT:** NOI
- AA. **NOTICE TO PROCEED:** A written notice given by Owner to Vendor/Contractor fixing the date on which the contract times will commence to run and on which Vendor/Contractor shall start to perform the work under the Contract Documents. A Notice to Proceed may be given at any time after the effective date of the Agreement.
- BB. **OCCUPATIONAL SAFETY AND HEALTH ACT:** OSHA.
- CC. **OWNER:** Hernando County Board of County Commissioners (County).
- DD. **OWNER DESIGNATED REPRESENTATIVE:** The Owner Designated Representative will act as the Owner's representative, assume all duties and responsibilities, and have the rights and authority assigned to the Owner Designated Representative in the Contract Documents in connection with the completion of the work in accordance with their respective scope of work and the contract documents. Brian Malmberg, P.E., MBA Director of Engineering Coastal Engineering Associates, Inc., 966 Candlelight Boulevard, Brooksville, FL 34601 352-796-9423 bmalmberg@coastal-engineering.com, shall act as the Owner Designated Representative for the work relative to this contract.
- EE. **PAYMENT AND PERFORMANCE BONDS:** The approved forms of security furnished by the Vendor/Contractor and his surety as a guaranty on the part of the Vendor/Contractor to execute the work in accordance with the terms of the contract and to pay all obligations associated with the project.
- FF. **PROJECT BUDGET/ESTIMATE:** The project budget and/or estimate is the amount of funds the county has projected for this solicitation. The County estimates this solicitation to fall within the following dollar Threshold G: \$2,500,000.01- \$5,000,000. **Note: The County/Engineer's probable cost estimate for this project is \$2,515,000.00. This is only an estimate and should not be the basis to determine the Vendor/Contractor bid submission amount.**
1. Threshold A: less than \$100,000
 2. Threshold B: \$100,000.01- \$250,000
 3. Threshold C: \$250,000.01- \$500,000
 4. Threshold D: \$500,000.01 - \$1,000,000
 5. Threshold E: \$1,000,000.01 - \$1,500,000
 6. Threshold F: \$1,500,000.01- \$2,500,000
 7. **Threshold G: \$2,500,000.01- \$5,000,000**

8. Threshold H: greater than \$5,000,000.01

GG. **PROFESSIONAL:** The professional independent **Architectural/Engineering firm** designated to be the Engineer of Record (per Florida Administrative Code). Any references to the Engineer or the Professional shall be deemed to mean Coastal Engineering Associates, Inc., and its designee for the plans and specifications referenced in these Contract Documents.

HH. **PROJECT MANAGER:** The duly authorized representative of the County during the construction period. The Project Manager of record for this Solicitation is: Erik van de Boogaard, Hernando County Construction Projects Coordinator.

II. **SCOPE OF WORK:** All materials, labor and equipment in order to accomplish the Project, as described in the specifications and construction plans showing the proposed improvements. The Vendor/Contractor shall accomplish the work in a manner providing for the safety of their equipment and workers and for the safety of the general public.

JJ. **SHOP DRAWINGS:** All drawings, diagrams, illustrations, brochures, schedules and other data which are prepared by the Vendor/Contractor, a subcontractor, a manufacturer, supplier or distributor and which illustrate the equipment, material and/or some portion of the work.

KK. **SITE:** Lands or areas indicated in the Contract Documents as being furnished by Owner upon which the work is to be performed, including rights-of-way and easements for access thereto, and such other lands furnished by Owner which are designated for the use of Vendor/Contractor. The site or location for the work to be performed in this Contract will be Spring Hill Drive and Helicopter Drive.

LL. **SUBCONTRACTOR:** Any person, firm or corporation other than employees of the Vendor/Contractor who or which contracts with the Vendor/Contractor to furnish, or actually furnishes labor, materials and/or equipment for the performance of a part of the work on the project.

MM. **SURETY:** Any person, firm or corporation which is bound by Public Construction Bond and Payment Bond with and for the Vendor/Contractor and which engages to be responsible for his acceptable performance of the work and for payment of all debts pertaining thereto.

NN. **VENDOR/CONTRACTOR:** The individual or entity with whom the County has entered into the Agreement.

OO. **WORK:** The entire completed construction or the various separately identifiable parts thereof required to be furnished under the Contract Documents. Work is the result of performing services, furnishing labor and furnishing and incorporating materials and equipment into the construction, all as required by the Contract Documents.

7.2. AVAILABILITY OF BIDDING DOCUMENTS:

Interested firms may secure bid documents, plans, drawings, site locations, and other pertinent information by visiting Hernando County's [eProcurement Portal](#). For additional information please contact the Hernando County Board of County Commissioners, Procurement Department via the County's [eProcurement Portal](#) Q&A Tab.

7.3. PREPARATION OF BID

To ensure acceptance of your bid, please follow these instructions:

- A. Interested firms are required to register via the County's [eProcurement Portal](#) . Once registered, to submit a response please click on the "DRAFT RESPONSE" button and provide an answer to all of the prompts/questions. You must respond to all required questions, and, if any, acknowledge addenda so that your response will be considered complete by the County. Bidders submitting more than one (1) bid with different pricing shall cause the Bidder to be rejected. All bids are subject to the conditions specified herein. Those, which do not comply with these conditions, may be subject to rejection.
- B. Submit Bids to via the Hernando County's [eProcurement Portal](#). The responsibility for delivering the bid to the County on or before the stated time and date will be solely and strictly the responsibility of the Bidder.
 1. Bids will be rejected unless submitted electronically via the County's electronic bidding system along with all required bid line items. All bid forms enclosed are required to be completed and submitted using the instructions listed herein.
 2. The County will not honor any explanation or change in the bid documents unless a written addendum has been issued.
 3. The County will not honor any explanation or change in the bid documents unless written addendum has been issued.
 4. The County reserves the right to reject any and all bids and to waive any informalities related thereto.
 5. All bids must be firm for a period of one hundred twenty (120) days after the time set for opening bids. Upon award, prices quoted will be in effect for the term of the contract.
 6. No material, labor, or facilities will be furnished by the County unless specifically stated.
 7. Blank spaces in the bid must be properly filled in and the phraseology of the bid must not be changed. Additions must not be made to items mentioned therein and any unauthorized conditions, limiting any provision, attached to a bid shall render irregular and may cause its rejection.
 8. Communications: All technical, scope, and/or project related questions shall be submitted through the project [Q&A Tab](#) before the deadline and according to these specifications

herein. Any and all other bidding communications shall only be the County using the contact information herein. Companies bidding on this project shall not communicate with any other County Staff members or they risk being disqualified.

7.4. MANDATORY PREBID CONFERENCE

- A. A Mandatory Pre-Bid Conference will be held Wednesday, March 15, 2023 at 10:00 am at 15470 Flight Path Drive, Brooksville, FL 34604.
- B. A Mandatory Site Visit will immediately follow the Pre-Bid Conference.
- C. Only Bidders present at the Pre-Bid Conference and Site Visit may submit a bid for this solicitation.
- D. Attendees must be present at the beginning of the Pre-Bid Conference. Arrival after the start of the Pre-Bid Conference shall be cause for disqualification. Bidders must RSVP via the County's [eProcurement Portal](#).

7.5. BID OPENING

Bids received after the date and time disclosed in this Solicitation will not be accepted. Bids will be opened immediately after this date and time, and will remain binding upon the Bidder for a period of one hundred twenty (120) days thereafter. Pursuant to Florida Statutes 119.071 (current version) sealed bids, proposals, or replies received by an agency pursuant to a competitive solicitation are exempt from inspection until such time as the agency provides notice of an intended decision or until thirty (30) days after opening the bids, proposals, or final replies whichever is earlier.

7.6. SITE VISIT

Bidder may request access the site to conduct examinations, investigations, explorations, tests, and studies as Bidder deems necessary for submission of a bid by contacting the Procurement Department via the County's [eProcurement Portal Q&A tab](#), if no mandatory site visit is scheduled. All questions after the site visit shall be submitted to the Procurement Department in writing via the County's [eProcurement Portal Q&A tab](#). The Procurement Department will coordinate a site visit between the Bidder and the Project Manager for this project. The site is currently accessible from Helicopter Drive. Bidder agrees to restore the site to its former condition upon completion of such explorations, investigations, tests, and studies. Bidder shall comply with all applicable laws and regulations relative to excavation and utility locates while accessing the site.

7.7. BIDDER'S RESPONSIBILITIES

It is the responsibility of each Bidder before submitting a bid to:

- A. Read and completely understand the requirements and the specifications of the items bid.
- B. Use complete sets of bid documents in preparing bids; neither Owner nor Engineer assumes any responsibility for errors or misinterpretations resulting from the use of incomplete sets of bid documents.

- C. Examine and carefully study the bid documents, other related data identified in the bid documents, and any Addenda.
- D. Make all investigations necessary to thoroughly inform themselves regarding all drawings, specifications, delivery requirements, performance requirements, site locations, and all solicitation instruction to satisfy themselves of conditions affecting submission of their bid and the terms and cost of performing the contract. No pleas of ignorance by the Bidder of conditions that exist or may hereafter exist as a result of failure or omission on the part of the Bidder to make the necessary examinations and investigations, or failure to fulfill in every detail the requirements of the Contract Documents, will be accepted as a basis of varying the requirements of the County or the compensation of the Bidder. Bidder agrees that submittal of a bid for the work is prima facie evidence they have conducted such examinations.
- E. Request access to the site to become familiar with general, local, and site conditions that may affect cost, progress, and performance of the work.
- F. Become familiar with all Federal, State, and local laws and regulations that may affect cost, progress, or performance of the work.
- G. Obtain and carefully study all additional or supplementary examinations, investigations, explorations, tests, studies, and data concerning conditions (surface, subsurface, and underground facilities) at or contiguous to the site which may affect cost, progress, or performance of the work or which relate to any aspect of the means, methods, techniques, sequences, and procedures of construction to be employed by the Bidder, including applying any specific means, methods, techniques, sequences, and procedures of construction expressly required by the bid documents, and safety precautions and programs incident thereto.
- H. Agree at the time of submitting its bid that no further examinations, investigations, explorations, tests, studies, or data are necessary for the determination of its bid for performance of the work at the price(s) bid and within the times and in accordance with the other terms and conditions of the bid documents.
- I. Become aware of the general nature of the work to be performed by Owner and others at the site that relates to the work as indicated in the bid documents.
- J. Correlate the information known to Bidder, information and observations obtained from visits to the site, reports and drawings identified in the bid documents, and all additional examinations, investigations, explorations, tests, studies, and data with the bid documents.
- K. Promptly give Engineer written notice of all conflicts, errors, ambiguities, or discrepancies that Bidder discovers in the bid documents and confirm that the written resolution thereof by Engineer is acceptable to Bidder.
- L. Determine that the bid documents are generally sufficient to indicate and convey understanding of all terms and conditions for the performance of the work.

- M. Bidder accepts all of the terms and conditions of the Instructions to Bidders, including without limitation those dealing with the disposition of bid security. This bid will remain subject to acceptance for one hundred twenty (120) days after the bid opening, or for such longer period of time that Bidder may agree to in writing upon request of Owner.
- N. Bidder has enclosed a Certified check, Cashier's Check or Bid Bond in the amount of not less than the five percent (5%) of the Total Base Bid Amount payable to the Hernando County Board of County Commissioners as a guarantee for the purpose set out in the Instructions to Bidders.

7.8. QUESTIONS REGARDING SPECIFICATIONS OR BIDDING PROCESS:

To ensure fair consideration for all Bidders, the County prohibits communication to or with any department, division or employee during the bid process, except as provided below:

- A. All questions relative to interpretation of the specifications or the bid process shall be addressed in writing via Hernando County's [eProcurement Portal Q&A Tab](#), prior to the period set for submittal and opening of the bids.
- B. Any interpretation or clarification made to prospective Bidders will be expressed in the form of an addendum which, if issued, will be posted on the County's [eProcurement Portal Q&A tab](#). Oral answers will not be authoritative.
- C. It will be the responsibility of the Bidder to visit <https://secure.procurenow.com/portal/hermandocounty> to insure they are aware of all addenda issued for this solicitation.
- D. Questions will only be accepted through Monday, March 20, 2023 at 5:00 p.m.
- E. All addenda must be acknowledged via the County's eProcurement Portal. Failure of any Bidder to submit any addenda may be found non-responsive and subject to rejection.

7.9. COMMUNICATION

There shall be no communication between the Vendor/Contractor, their employees or subcontractors and County employees and elected officials (hereafter referred to as "County Representative"), except through the Procurement Department. Any attempt to communicate with any County Representative outside the Procurement Department will be considered a violation of the Purchasing Policy and may result in the rejection of your bid.

7.10. WITHDRAWAL OF BIDS:

Bids may be withdrawn prior to the Wednesday, March 15, 2023, 10:00 am via the County's [eProcurement Portal](#). Negligence on the part of the Bidder in preparing the bid confers no right for the withdrawal of the Bid after it has been opened. Faxed or electronically mailed withdrawals will not be recognized. No Bidder may withdraw their bid after the scheduled opening time for receipt of bids.

7.11. BID PROTESTS

Any Bidder who protests the bid specifications or Award or Intent to Award, must file with the County a Notice of Protest and formal written protest in compliance with Chapter 28-110, Florida Administrative Code, and applicable provisions in Section 120.57, F.S. (current version). Failure to timely file such documents will constitute a waiver of proceedings under Chapter 120, F.S. (current version).

7.12. QUALIFICATION OF BIDDERS

- A. The Vendor/Contractor shall have previous experience in the type of construction work specified herein, and experience in the installation of the materials to be provided for the project specified herein.
- B. The Vendor/Contractor and/or subcontractors shall be an appropriately licensed Contractor in the State of Florida at the time of the bid and must have successfully completed a minimum of two (2) projects of similar size and complexity in the past seven (7) years. These requirements are in addition to the requirements in Section entitled, "Reference Documents" below.
- C. The Vendor/Contractor's Project Superintendent must have a minimum of three (3) years' experience as Project Superintendent and must have directed at least two (2) previous projects of similar size and complexity. These requirements are in addition to the requirements in Section entitled, "Reference Documents."
- D. Bidders shall submit evidence of this experience on the forms provided in the bid documents, along with the accompanying information requested below:
 - 1. Overview of construction experience, including a list of projects successfully completed and indicating Owner, location, contract value and completion date.
 - 2. Documentation of two (2) projects, similar in scope and complexity to this project, which have been successfully completed by the Bidder within the past seven (7) years.
 - 3. Identification of firms comprising the Vendor/Contractor's team on the Construction Contractor Qualification Submittal Package attached to Vendor Questionnaire.
 - 4. Resumes of the Vendor/Contractor's Project Superintendent documenting the experience required for these individuals.
- E. **Failure to submit this information may be basis for rejection of the bid.**

7.13. QUALIFICATION OF SUBCONTRACTORS, MATERIAL VENDOR, SUPPLIERS, AND OTHERS:

- A. The Vendor/Contractor will, within ten (10) days after execution of the Agreement, submit to the County through the Owner Designated Representative for acceptance a list of the names of subcontractors and such other persons and organizations proposed for those portions of the work as to which the identity of the subcontractors and other persons and organizations must

be submitted as specified in the Contract Documents. The Owner Designated Representative will notify the Vendor/Contractor in writing if the Owner Designated Representative, after due investigation, has reasonable objection to any subcontractor, person or organization on such list. The failure of the Owner Designated Representative to make objections to any subcontractor, person or organization on the list shall constitute an acceptance of such subcontractor, person or organization. Acceptance of any such subcontractor, person or organization shall not constitute a waiver of any right of the County to reject defective work, material or equipment, or work material or equipment not in conformance with the requirements of the Contract Documents.

- B. If the apparent successful Bidder declines to make any such substitution, County may award the Contract to the next lowest responsive, responsible Bidder that proposes to use acceptable subcontractors, suppliers, individuals, or entities. Declining to make requested substitutions will not constitute grounds for forfeiture of the bid security of any Bidder. Any subcontractor, supplier, individual, or entity so listed and against which the County and Owner Designated Representative makes no written objection prior to the giving of the Notice of Award will be deemed acceptable to the County and Owner Designated Representative subject to revocation of such acceptance after the effective date of the Agreement.
- C. Vendor/Contractor shall not be required to employ any subcontractor, supplier, individual, or entity against whom Vendor/Contractor has reasonable objection.
- D. The Vendor/Contractor agrees that he is as fully responsible to the County for the acts and omissions of his subcontractors and of persons either directly or indirectly employed by them, as he is for the acts and omissions of persons directly employed by him. Nothing contained in the Contract Documents shall create any contractual relation between any subcontractor and the County.

7.14. EXAMINATION OF BIDDING DOCUMENTS, OTHER RELATED DATA, AND SITE:

- A. Subsurface and Physical Conditions:
 - 1. The Technical Specifications will identify:
 - a. Any reports of explorations and tests of subsurface conditions at or contiguous to the site that Engineer has used in preparing the bid documents.
 - b. Any drawings of physical conditions in or relating to existing surface and subsurface structures at or contiguous to the site (except underground facilities) that Engineer has used in preparing the bid documents.
 - 2. Copies of any reports and drawings referenced in the solicitation documents will be made available by Owner to any Bidder via the County's [eProcurement Portal](#). Bidder is responsible for any interpretation or conclusion Bidder draws from any technical data or any

other data, interpretations, opinions, or information contained in such reports or shown or indicated in such drawings.

B. Underground Facilities:

1. Information and data shown or indicated in the bid documents with respect to existing underground facilities at or contiguous to the site is based upon information and data furnished to Owner and Engineer by owners of such underground facilities, including Owner, or others.

C. Hazardous Environmental Condition:

1. The Technical Specifications identify any reports and drawings relating to a hazardous environmental condition identified at the site that Engineer has used in preparing the bid documents.

7.15. BID GUARANTEE/BID BOND:

- A. Each bid must be accompanied by a Certified Check, Cashier's Check, Official Bank Check or Bid Bond payable to the Owner for an amount equal to at least five percent (5%) of the amount of bid, as guarantee that the Bidder will within fifteen (15) consecutive calendar days after award, enter into a written contract with the County for the performance of the work as awarded.
- B. **Any submitted Bid Bond must be submitted to the County.**
- C. Any submitted checks shall be drawn on a solvent bank or trust company to the order the Hernando County Board of County Commissioners and shall have all necessary documentary revenue stamps attached, if required by law.
- D. Surety of Bid Bonds shall be a duly authorized surety company authorized to do business in the State of Florida; all such bonds being issued or countersigned by a local producing agent who is a resident of the State of Florida and satisfactory evidence of the authority of the person or persons executing such bond being submitted with the bond. Personal checks are not acceptable to Hernando County.
- E. The County will, within ten (10) days after the Notice of Intent to Award, return the deposit of all Bidders except those posted by the three (3) lowest acceptable Bidders, whose deposit will be returned upon the final award and execution of the Contract between the successful Bidder and County, and after a satisfactory Performance Bond and Payment Bond have been executed.
- F. Attorneys-in-fact who sign bonds or other surety instruments must attach with each bond or surety instrument a certified and effectively dated copy of their power of attorney.
- G. If the successful Bidder fails to execute and deliver the Contract Documents and furnish the required contract security within fifteen (15) days after the Notice of Award, Owner may

withdraw the Notice of Award and the Bid Bond of that Bidder will be forfeited. The Bid Bond of other Bidders whom Owner believes to have a reasonable chance of receiving the award may be retained by Owner until the earlier of seven (7) days after the effective date of the Agreement or sixty-one (61) days after the bid opening, whereupon Bid Bonds furnished by such Bidders will be returned.

- H. Bid Bonds of other Bidders whom Owner believes do not have a reasonable chance of receiving the award will be returned within thirty (30) days after the Bid opening.
- I. Bidders desiring their original Bid Bonds returned shall enclose a self-addressed stamped envelope with their bids marked "Bid Bond" in the lower left corner.

7.16. PERFORMANCE AND PAYMENT BOND:

- A. Performance and Payment Bond issued in a sum equal to one hundred percent (100%) of the total awarded contract amount by a surety company considered satisfactory by the County and otherwise authorized to transact business in the State of Florida will be required from the successful Bidder for purposes of insuring the faithful performance of the obligations imposed by the resulting contract and for purposes of protecting the County from lawsuits for non-payment of debts as might be incurred during the successful Bidder's performance under such contract. When applicable, the performance and payment bond form will be included in the contract documents and said form must be properly executed by the surety company and successful Bidder within fifteen (15) calendar days after notification by the County of the County's intent to award the contract.
- B. If, within fifteen (15) calendar days after notification by the County of the County's intent to award a contract, the successful Bidder refuses or otherwise neglects to execute the required written contract or fails to furnish the required performance and payment bond, the amount of the Bidder's bid security (check or Bid Bond) shall be forfeited and the same shall be retained by the County. No plea of mistake in the Bid or misunderstanding of the conditions of forfeiture shall be available to the Bidder for the recovery of his bid security or as a defense to any action based upon the neglect or refusal to execute a written contract.
- C. The surety company must provide an Increase Rider to the Performance and Payment Bond or execute the Consent of Surety and Increase of Penalty form provided by the County if the contract is increased by change order.

8. GENERAL CONDITIONS

8.1. CONTRACT DOCUMENTS

The following constitute the Contract Documents (Title, Subtitles, Headings, Running Headlines, Table of Contents, and Indexes are used merely for convenience purposes):

Solicitation-Offer-Award

(Cover Page)

Advertisement of Bid

(Section 6)

Solicitation Instructions

(Section 7)

General Conditions

(Section 8)

Special Conditions

(Section 9)

Supplementary Conditions for Federal/State Grant Requirements

(Section 10)

Scope and Specifications

(Section 11)

General Requirements and Technical Specifications

(Section 12)

Bid/Proposal Pricing

(Section 14)

Required Forms and Certifications

(Section 15)

Construction Agreement and Required Documents After Award

(Section 15)

Attachments/Reference Documents

Exhibit A -- Plans/Drawings_21115 Dr Dennis Wilfong Center for Success REV3

Exhibit B - Geological Report_Tierra Report_Citizens Center for Success

- A. All addenda issued by the County prior to the receipt of bids and all supplementary drawings issued after award of the Contract become part of the Contract Document.
- B. Amending and Supplementing Contract Documents:

1. The Contract Documents may be amended to provide for additions, deletions, and revisions in the work or to modify the terms and conditions thereof by Change Order (See Section 9. Special Conditions).
 2. The requirements of the Contract Documents may be supplemented, and minor variations and deviations in the work may be authorized, by one (1) or more of the following ways:
 - a. A field order;
 - b. Engineer's approval of a shop drawing or sample; or
 - c. Engineer's written interpretation or clarification per the provisions described in the Contract Documents.
 3. In resolving such conflicts, errors and discrepancies, the documents shall be given preference in the following order: Agreement, Specifications, Drawings, Solicitation Instructions. Within the specifications the order of preference shall be as follows: Addenda, General Conditions, Technical Specifications. Figure dimensions on drawings shall govern over scale dimensions, and the detailed drawings shall govern over general drawings. Any work that may reasonably be inferred from the specifications or drawings as being required to produce the intended result shall be supplied whether or not it is specifically called for. Work materials or equipment described in words which so applied have a well-known technical or trade meaning shall be deemed to refer to such recognized standards. In case of conflict the more stringent requirements shall take precedence and govern.
 4. The Vendor/Contractor shall take no advantage of any error or omission in the plans or of any discrepancy between the plans and specifications, and the Engineer shall make such interpretation as may be deemed necessary for the fulfillment of the intent of the plans and specifications as construed by him and his decision shall be final.
- C. All provisions required by law to be inserted in this Contract, whether actually inserted or not.
- D. Exhibits to this Agreement (as follows):
1. Vendor/Contractor's Bid.
 2. Documentation submitted by Vendor/Contractor after the Notice of Award:
 - a. Insurance Certificate.
 - b. Payment and Performance Bond.
 3. The following which may be delivered or issued on or after the effective date of the Agreement and are not attached hereto:
 - a. Notice to Proceed.
 - b. Change Order(s).

- E. The documents listed in this paragraph are attached to the Agreement (except as expressly noted otherwise).
- F. There are no Contract Documents other than those listed in this paragraph.
- G. The Contract Documents may only be amended, modified, or supplemented as provided in the Contract Documents.

8.2. BID PRICE/SUBMITTAL REQUIREMENTS:

- A. The prices bid shall remain firm during the period of the Contract. The prices bid shall be inclusive of all labor, equipment, and materials as specified within this Solicitation. The price bid constitutes the total compensation payable to the Vendor/Contractor for performing the work.
- B. Unless otherwise stated, the prices bid shall include all costs of packing, transporting, delivery, and services to the designated point within Hernando County.
- C. The Bidder hereby certifies that this bid is made without prior understanding, agreement, or connection with any corporation, firm, or person submitting a bid for the same materials, supplies, services, or equipment and is in all respects fair and without collusion or fraud. Further, the Bidder hereby agrees to abide by all terms and conditions of this bid and certifies that the person executing the Bid Form is authorized to sign this bid for the Bidder.
- D. Bidders shall submit a lump sum bid based on unit price line item components as indicated on the Bid Form, and include a separate price for each alternate described in the bid documents and provided for in the Bid Form. The sum of each unit price line item will be the Total Base Bid. The price for each alternate will be the amount added to or deducted from the Total Base Bid if the County selects the alternate.
- E. Discrepancies between the multiplication of units of work and unit prices will be resolved in favor of the unit prices. Discrepancies between the indicated sum of any column of figures and the correct sum thereof will be resolved in favor of the correct sum. Discrepancies between words and figures will be resolved in favor of the words.
- F. Bidder must submit the Solicitation-Offer-Award Cover Sheet, Bid Form and all Required Forms and Certifications. Failure to submit these forms may render the bid non-responsive.

8.3. HOURS

All work is to be performed during regular working hours, 7:00 a.m. to 7:00 p.m.; Monday through Friday, except County holidays. The County may, on certain occasions, approve work outside of these times. Such exception(s) must be approved in writing by the County at least one (1) day in advance. Vendor/Contractor should provide five (5) days' notice when scheduling a County employee to be available outside the normal work hours.

8.4. REJECTION OF BID:

The County reserves the right to reject any and all bids. Bids which are incomplete, unbalanced, conditional, obscure or which contain additions not required, or irregularities of any kind, or which do not comply with every aspect of this Solicitation, may be rejected at the option of the County. A Bidder shall not be qualified to bid when an investigation by the Chief Procurement Officer finds the Bidder delinquent with a previously awarded contract or in litigation with Hernando County on a previously awarded contract.

8.5. MINOR INFORMALITIES AND IRREGULARITIES:

Hernando County has the right to waive minor defects or variations of a bid from the exact requirements of the specifications that do not affect price, quality, quantity, delivery, or performance time of the services being procured. If insufficient information is submitted by a Bidder with the bid for Hernando County to properly evaluate the bid, Hernando County has the right to require such additional information as it may deem necessary after the time set for receipt of bids, provided that the information requested does not change the price, quality, quantity, delivery or performance time of the services being procured. The Board of County Commissioners reserves the right to reject any or all bids in whole or in part; to award by any item, group(s) of items or in the aggregate whichever is most advantageous to the County.

8.6. NON-EXCLUSIVE CONTRACT:

Award of a contract resulting from this bid imposes no obligation on the County to utilize the Vendor/Contractor for all work of this type, which may develop during the contract period. This is not an exclusive contract. The County specifically reserves the right to contract with another company for similar work if it deems such action to be in the County's best interest.

8.7. NON-PERFORMANCE:

- A. Time is of the essence in this Contract and failure to deliver the services specified within the time period required shall be considered a default.
- B. In case of default, the County may procure the services from other sources and hold the Vendor/Contractor responsible for all costs occasioned thereby and may immediately cancel the Contract.

8.8. ASSIGNMENT

The successful Bidder is required to perform this Contract and may not assign, transfer, convey, sublet or otherwise dispose of any award or any or all of its rights, title, or interest therein, or the resulting Contractual Agreement in whole or in part without prior written authorization given at the sole discretion of Hernando County.

8.9. PUBLIC ENTITY CRIMES:

Any person submitting a bid or proposal in response to this invitation certifies that they are aware of, and in compliance with, all requirements under Section 287.133, Florida Statutes (current version), on

Public Entity Crimes. Bidders must provide a response to the section titled VENDOR QUESTIONNAIRE, Sworn Statement to Public Entity Crimes included in these bid documents.

8.10. LICENSES AND PERMITS:

- A. Prior to furnishing the requested product(s) or service(s), it shall be the responsibility of the awarded Vendor/Contractor to obtain, at no additional cost to Hernando County, any and all licenses and permits required to complete this contractual service, unless otherwise stated in the Contract Documents. These licenses and permits shall be readily available for review by the Chief Procurement Officer or his/her designee. Failure to have and/or furnish the required licenses or permits may be cause for rejection.
- B. The Vendor/Contractor is hereby notified that a list of fees for construction related County certified licenses and County issued permits can be located at:
<https://www.hernandocountygis-fl.us/BldgDept/General>.
- C. The following permits are necessary, but not limited to, for prosecution of the work. Vendor/Contractor and/or subcontractors shall obtain and pay for required permits. Notice to Proceed will not be issued until the permits are provided to the Project Manager. The Vendor/Contractor will be responsible for obtaining an Electrical Permit for the pump station and a County Right-of-Way Use Permit from the Department of Public Works (DPW).

The FDEP Water Permit, FDEP Waste Water Permit, and SWFWMD Environmental Resource Permit will be provided by the County. **Any additional permits not identified and required will be addressed by change order.**

- A. NPDES-NOI Permit - The NPDES-FDEP legislation and permit information can be found on this site: <http://www.dep.state.fl.us/water/stormwater/npdes/construction1.htm>
- B. Commercial Building Permit and/or Development Permit and Electrical Permit
- C. FWC Gopher Tortoise Conservation and Relocation Permit
- D. FDOT Right of Way Permit
- E. FDEP Water Permit
- F. FDEP Waste Water Permit
- G. SWFWMD Environmental Resource Permit
- H. Vendor/Contractor and/or subcontractors shall be responsible for complying with all State of Florida and Hernando County license requirements prior to bidding on County projects and shall submit proof of licenses with the Bid. All licenses shall be in the Bidder's name or the key subcontractor's name, as listed in Questionnaire. Failure to submit proof of the required licenses shall deem the Bidder non-responsive. The following licenses are necessary, but not limited to, for prosecution of the work:

1. General Contractors or Underground Utility and Excavating Contractors
2. Electrical Contractors

8.11. LAWS, REGULATIONS, PERMITS AND TAXES:

- A. The Bidder's attention is directed to the fact that all applicable Federal and State laws, municipal and county ordinances, and the rules and regulations of all authorities having jurisdiction over any part of the project shall apply to the Contract throughout, and they will be deemed to be included in the Contract the same as through herein written.
- B. Vendor/Contractor shall comply with County's jobsite procedures and regulations and with all applicable local, State and Federal laws, rules and regulations and shall obtain all permits required for any of the work performed hereunder. Vendor/Contractor shall procure and pay for all permits and inspections required for any of the work performed hereunder and shall furnish any bonds, security or deposits required to permit performance of the work. Vendor/Contractor shall, to the extent permissible under applicable law, comply with the jobsite provisions which validly and lawfully apply to work on the specific jobsite being performed under this Contract. County of Hernando is exempt from Federal excise taxes and all sales taxes.
- C. Vendor/Contractor shall give all notices required by and shall comply with all laws and regulations applicable to the performance of the work. Except where otherwise expressly required by applicable laws and regulations, neither Owner nor Engineer shall be responsible for monitoring Vendor/Contractor's compliance with any laws or regulations.
- D. If Vendor/Contractor performs any work knowing or having reason to know that it is contrary to laws or regulations, Vendor/Contractor shall bear all claims, costs, losses, and damages (including but not limited to all fees and charges of engineers, architects, attorneys, and other professionals and all court or arbitration or other dispute resolution costs) arising out of or relating to such work. However, it shall not be Vendor/Contractor's primary responsibility to make certain that the specifications and drawings are in accordance with laws and regulations, but this shall not relieve Vendor/Contractor of Vendor/Contractor's obligations of reporting discrepancies.
- E. Changes in laws or regulations not known at the time of opening of bids having an effect on the cost or time of performance of the work shall be the subject of an adjustment in contract price or contract times. If Owner and Vendor/Contractor are unable to agree on entitlement to or on the amount or extent, if any, of any such adjustment, a claim may be made therefore as provided in the Contract Documents.

8.12. SITE AND OTHER AREAS

The site is identified in the Bid documents. Easements for permanent structures or permanent changes in existing facilities are to be obtained and paid for by Owner unless otherwise provided in the Bid documents. All additional lands and access thereto required for temporary construction facilities,

construction equipment, or storage of materials and equipment to be incorporated in the work are to be obtained and paid for by Vendor/Contractor.

8.13. TAXES

- A. The Board of County Commissioners, Hernando County, Florida, has the following tax exemption certificates assigned:
 - 1. **Sales and Use Tax Exemption Certificate No. 85-8012556945C-8, effective 1/31/2019 – expiring on 1/31/2024.**
- B. This exemption does not apply to purchases of tangible personal property made by Vendor/Contractors who use the tangible personal property in the performance of contracts for improvements of County owned real property (Chapters 192 and 212, F.S. (current version) and applicable rules of the Department of Revenue).
- C. State sales tax and use taxes on materials and equipment are to be incorporated in the price bid.
- D. Vendor/Contractor shall pay all sales, consumer, use, and other similar taxes required to be paid by Vendor/Contractor in accordance with the laws and regulations of the place of the project which are applicable during the performance of the work.

8.14. MANUFACTURERS' NAME AND APPROVED EQUIVALENTS:

Whenever a particular brand or make of material, equipment, or other item is specified, or is indicated on the drawings, it is for the purpose of establishing a standard of quality, design, and type desired and to supplement the detailed specifications. Any other brand or make which is equivalent to that specified or indicated may be offered as an equivalent prior to the Solicitation Last Date of Inquiries deadline, for review and approval by Hernando County subject to the following provisions:

- A. The Vendor/Contractor shall submit for each proposed equivalent sufficient details, complete descriptive literature, and performance data together with samples of the materials, where feasible, to enable the Engineer of Record to determine if the proposed equivalent is equal, in all respects including, but not limited to, quality, performance, ease of maintenance, availability of spare parts, and experience record.
- B. The Vendor/Contractor shall submit certified tests, where applicable, by an independent laboratory attesting that the proposed equivalent is equal.
- C. A list of installations where the proposed equivalent is used. Such listing shall cover a minimum of the previous three (3) years and will furnish project names and contact phone numbers.
- D. Where the acceptance of an equivalent requires excessive review by the Engineer of Record, revision or redesign of any part of the work, all such additional review costs, revisions and redesign, and all new drawings and details required therefore, shall be at the Vendor/Contractor's expense.

- E. In all cases the Engineer of Record and Hernando County shall have the sole right as to whether a proposed equivalent is to be accepted. The Vendor/Contractor shall abide by the Engineer of Record and Hernando County's decision when proposed equivalent items are judged to be unacceptable and shall in such instances furnish the item as specified. No equivalent items shall be used in the work without written acceptance by the Engineer of Record.
- F. Acceptance of any proposed equivalent shall in no way release the Vendor/Contractor from any of the provisions of the Contract Documents.
- G. Hernando County may require, at Vendor/Contractor's expense, a special performance guarantee or other surety with respect to any equivalent.
- H. Bids which do not comply with these requirements are subject to rejection.

8.15. BID EVALUATION AND AWARD:

- A. At the time of submitting a bid response, the County requires that the Bidder to be properly licensed and registered to do business in the State of Florida in accordance with applicable Florida Statutes (F.S.). Bid responses that fail to provide the required forms listed in Section VIII may be rejected as non-responsive. Bidders whose responses, past performance, or current status do not reflect the capability, integrity or reliability to fully and in good faith perform the requirements of the bid may be rejected as non-responsible. The County reserves the right to determine which responses meet the requirements of this Solicitation, and which Bidders are responsive and responsible. The County reserves the right before awarding the bid, to require a Bidder to submit such evidence of their qualifications as it may deem necessary, and may consider any evidence available to it of the financial, technical, and other qualifications and abilities of a Bidder to perform the work in a satisfactory manner and within the time specified. The Bidder is assumed to be familiar with all Federal, State or local laws, ordinances, rules and regulations that in any manner affect the work, and to abide thereby if awarded the bid. Ignorance of legal requirements on the part of the Bidder will in no way relieve responsibility.
- B. Bid evaluation will be based on price, conformance with specifications and the Bidder's ability to perform the Contract in accordance with the terms and conditions required. Bidders must submit all data necessary to evaluate and determine the quality of the item(s) and/or services they are bidding.
- C. The County intends to award this Contract to the lowest, responsive and responsible Bidder or Bidders. However, the County reserves the right to reject any and all bids in accordance with the Hernando County Procurement Ordinance.
- D. The ability of a Bidder to obtain a performance and payment bond shall not be regarded as the sole test of such Bidder's competency or responsibility.

- E. Nothing contained herein shall place a duty upon the Hernando County Board of County Commissioners to reject bids or award a contract based upon anything other than its sole discretion as described herein.
- F. Bidders are not permitted to submit more than one (1) bid for this project. Reasonable grounds for believing that any Bidder has an interest in more than one (1) bid for this project may be cause for disqualification of that Bidder and the rejection of all bids in which that Bidder has an interest.
- G. Owner will consider whether or not the bids comply with the prescribed requirements, and such alternates, unit prices and other data, as may be requested in the Bid Form or prior to the Notice of Award.
- H. Owner will consider the qualifications of Bidders and may consider the qualifications and experience of subcontractors, suppliers, and other individuals or entities proposed for those portions of the work for which the identity of subcontractors, suppliers, and other individuals or entities must be submitted.
- I. The County reserves the right to make such investigations as they may deem necessary to establish the competency and financial ability of any Bidder, proposed subcontractors, supplier, or individuals to perform the work; and if after investigation, the evidence of his competency or financial ability is not satisfactory, the County reserves the right to reject his bid.
- J. If two (2) or more fully responsive, responsible bids are received for the same total amount or unit price, quality and service being equal, the County reserves the right to award the contract to the Bidder whose place of business is located within the boundaries of Hernando County, Florida. Should tie bids, as described above, be received from either two (2) or more Hernando County Bidders or from non-local Bidders when no Hernando County Bidder has submitted a tie bid, then the Board of County Commissioners shall award the contract to one (1) Vendor/Contractor by drawing lots in a public meeting.

8.16. QUALIFICATIONS OF SURETY COMPANIES

In order to be acceptable to the Owner, a surety company issuing bid guaranty bonds, or 100% Performance/Payment Bonds, called for in these Contract Documents, shall meet and comply with the following minimum standards:

- A. Surety must be admitted to do business in the State of Florida and shall comply with the provisions of Florida Statute 255.05 (current version).
- B. Surety companies executing bonds must appear on the United States Treasury Departments most current list (CIRCULAR 570 AS AMENDED).

- C. Attorneys-in-fact who sign Bid Bonds or Performance/Payment Bonds must file with such bond a certified copy of their power of attorney to sign such bond.
- D. Agents of surety companies must list their name, address and telephone number on all bonds.
- E. If the surety on any bond furnished by the successful Bidder is declared bankrupt or becomes insolvent or its right to do business is terminated in any state where any part of the project is located or it ceases to meet the requirements provided in this paragraph, Bidder (Vendor/Contractor) shall within five (5) days thereafter, substitute another bond and surety, both of which must be acceptable to the County.

8.17. LITIGATION/WAIVER OF JURY TRIAL

This Agreement shall be governed by and construed according to Florida law. Venue for any dispute or formal litigation concerning this Agreement shall be in the appropriate court with territorial jurisdiction over Hernando County, Florida. In the event of a dispute or litigation, each party to such dispute or litigation shall be solely responsible for its own attorneys' fees and costs. This Agreement shall not be construed for or against any party hereto, without regard to which party is wholly or partly responsible for its drafting. Each party acknowledges that it is aware of and has had the opportunity to seek advice of counsel of its choice with respect to its rights to trial by jury, and each party, for itself and its successors, creditors, and assigns, does hereby expressly and knowingly waive and release all such rights to trial by jury in any action, proceeding or counterclaim brought by any party hereto against the other (and/or against its officers, directors, employees, agents, or subsidiary or affiliated entities) on or with regard to any matters whatsoever arising out of or in any way connected with this Contract and/or any other claim of injury or damage.

8.18. MAINTENANCE OF RECORDS

The Vendor/Contractor will keep adequate records and supporting documents applicable to this Contract. Said records and documentation will be retained by the Vendor/Contractor for a minimum of five (5) years from the date of final payment on this Contract. The County and its authorized agents shall have the right to audit, inspect and copy records and documentation as often as the County deems necessary during the period of this Contract and a period of five (5) years after completion of contract performance; provided however, such activity shall be conducted only during normal business hours. The County during the period of time defined by the preceding sentence, shall also have the right to obtain a copy of and otherwise inspect any audit made at the direction of the Vendor/Contractor as concerns the aforesaid records and documentation. Pursuant to Section 119.0701, Florida Statutes (current version), Consultant/Firm shall comply with the Florida Public Records' laws and shall:

- A. Keep and maintain records that ordinarily and necessarily would be required by the public agency in order to perform the service;
- B. Provide the public with access to public records on the same terms and conditions that the public agency would provide the records and at a cost that does not exceed the cost provided in Chapter 119, F.S., or as otherwise provided by law.

- C. Ensure that public records that are exempt or confidential and exempt from public records disclosure requirement are not disclosed except as authorized by law; and,
- D. Meet all requirements for retaining public records and transfer, at no cost, to the public agency all public records in possession of the Consultant/Firm upon termination of the Contract and destroy any duplicate public records that are exempt or confidential and exempt from public records disclosure requirements. All records stored electronically must be provided to the public agency in a format that is compatible with the information technology systems of the public agency.
- E. Failure to comply with this section shall be deemed a breach of the Contract and enforceable as set forth in Section 119.0701, Florida Statutes (current version).

IF THE CONTRACTOR HAS QUESTIONS REGARDING THE APPLICATION OF CHAPTER 119, FLORIDA STATUTES (CURRENT VERSION), TO THE CONTRACTOR'S DUTY TO PROVIDE PUBLIC RECORDS RELATING TO THIS CONTRACT, CONTACT THE CUSTODIAN OF PUBLIC RECORDS AT 352-754-4020, PURCHASING@HERNANDOCOUNTY.US, WITH AN OFFICE LOCATED AT 15470 FLIGHT PATH DR., BROOKSVILLE, FL 34604.

Per Florida Statute 20.055(5) (Current Edition), it is the duty of every State officer, employee, agency, special district, board, commission, Contractor, and subcontractor to cooperate with the Inspector General in any investigation, audit, inspection, review, or hearing pursuant to this section.

8.19. FISCAL NON-FUNDING:

In the event sufficient budgeted funds are not available for a new fiscal period, the County must notify the Vendor/Contractor of such occurrence and Contract shall terminate on the last day of current fiscal period without penalty or expense to the County.

8.20. CONFLICT OF INTEREST

- A. Conflict of Interest of Officers or Employees of the Contracting Entity/Local Jurisdiction, Members of the Local Governing Body, or Other Elected Officials: No member or employee of the contracting entity/local jurisdiction or its designees or agents; no member of the governing body; and no other public official of Hernando County who exercises any function or responsibility with respect to this Contract, during his/her tenure or for two (2) years thereafter, shall have any interest, direct or indirect, in any contract or subcontract, or the proceeds thereof, for work to be performed. Further, the Vendor/Contractor shall cause to be incorporated in all Sub-contracts, the language set forth in this paragraph prohibiting conflict of interest.
- B. Employee Conflict of Interest: It shall be unethical for any Hernando County employee to participate directly or indirectly in a procurement contract when Hernando County employee knows that:

1. Hernando County employee or any member of Hernando County employee's immediate family has a financial interest in the procurement contract; or
 2. Any other person, business, or organization with whom Hernando County employee or any member of a Hernando County employee's immediate family is negotiating or has an arrangement concerning prospective employment is involved in the procurement contract; or
 3. A Hernando County employee or any member of a Hernando County employee's immediate family who holds a financial interest in a disclosed blind trust shall not be deemed to have a conflict of interest with regard to matters pertaining to that financial interest.
- C. Former Employee Conflict of Interest: It shall be a violation for any person, business or organization contracting with County to employ in any capacity, any former County employee or member of County employee's immediate family within two (2) years of that employee's separation from employment with the County, unless the employer or the former County employee files with the County Clerk, the County's Employment Disclosure Statement. The penalty for this violation may include disqualification of the bid submission.

8.21. GRATUITIES AND KICKBACKS:

- A. Gratuities: It shall be unethical for any person to offer, give, or agree to give any County employee or former County employee, or for any County employee or former County employee to solicit, demand, accept, or agree to accept from another person, a gratuity or an offer of employment in connection with any decision, approval, disapproval, recommendation, or preparation of any part of a program requirement or a purchase request, influencing the content of any specification or procurement standard, rendering of advice, investigation, auditing, or in any other advisory capacity to the County.
- B. Kickbacks: It shall be unethical for any payment, gratuity, or offer of employment to be made by or on behalf of a Sub-Contractor under a contract to the prime Vendor/Contractor or higher tier Sub-Contractor or any person associated therewith, as an inducement for the award of a Sub-Contract or order.

8.22. E-VERIFY

- A. Vendor/Contractor is advised that the County has entered into an agreement with U.S. Immigration and Customs Enforcement (ICE) wherein the County will, in part, seek to promote the principles of ethical business conduct, prevent the knowing hiring of unauthorized workers through self-governance, and encourage voluntary reporting of the discovery of unauthorized workers to ICE (the IMAGE Agreement). Accordingly, by submitting your bid/proposal, Vendor/Contractor represents and warrants (a) that the Vendor/Contractor is in compliance with all applicable Federal, State and local laws, including, but not limited to, the laws related to the requirement of an employer to verify an employee's eligibility to work in the United States,

- (b) that all of the Vendor/Contractor employees are legally eligible to work in the United States, and (c) that the Vendor/Contractor has actively and affirmatively verified such eligibility utilizing the Federal Government's Employment Verification Eligibility Form (I-9 Form).
- B. A mere allegation of Vendor/Contractor's intent to use and/or current use of unauthorized workers may not be a basis to delay the County's award of a contract to the Vendor/Contractor unless such an allegation has been determined to be factual by ICE pursuant to an investigation conducted by ICE prior to the date the contract is scheduled to be awarded by the County.
- C. Legitimate claims of the Vendor/Contractor's use of unauthorized workers must be reported to both of the following agencies:
1. The County's Purchasing Contracts Department at (352) 754-4020: and
 2. ICE (Immigration and Customs Enforcement) at 1-866-DHS-2-ICE.
- D. In the event it is discovered that the Vendor/Contractor's employees are not legally eligible to work in the United States, then the County may, in its sole discretion, demand that the Vendor/Contractor cure this deficiency within a specified time frame, and/or immediately terminate the Contract without any cost or penalty to the County, and/or debar the Vendor/Contractor from bidding on all County contracts for a period up to twenty-four (24) months, and/or take any and all legal action deemed necessary and appropriate.
- E. Vendor/Contractor is required to incorporate the following IMAGE Best Practices into its business and, when practicable, incorporate verification requirements into its agreements with subcontractors:
1. Use the Department of Homeland Security employment eligibility verification program (E-Verify) to verify the employment eligibility of all new hires.
 2. Use the Social Security Number Verification Service and make good faith effort to correct and verify the names and Social Security Numbers of the current workforce.
 3. Establish a written hiring and employment eligibility verification policy.
 4. Establish an internal compliance and training program related to the hiring and employment verification process, to include, but not limited to, completion of Form I-9, how to detect fraudulent use of documents in the verification process, and how to use E-Verify and the Social Security Number Verification Service.
 5. Require the Form I-9 and E-Verify process to be conducted only by individuals who received appropriate training and include secondary review as of each employee's verification to minimize the potential for a single individual to subvert the process.
 6. Arrange for annual Form I-9 audits by an external auditing firm or a trained employee not otherwise involved in the Form I-9 process.

7. Establish a procedure to report to ICE credible information of suspected criminal misconduct in the employment eligibility verification process.
8. Establish a program to assess subcontractors' compliance with employment eligibility verification requirements. Encourage Vendor/Contractors to incorporate the IMAGE Best Practices contained in this paragraph and, when practicable, incorporate the verification requirements in subcontractor agreements.
9. Establish a protocol for responding to letters received from Federal and State government agencies indicating that there is a discrepancy between the agency's information and the information provided by the employer or employee; for example, "no match" letters received from the Social Security Administration.
10. Establish a tip line mechanism (inbox, e-mail, etc.) for employees to report activity relating to the employment of unauthorized workers, and a protocol for responding to employee tips.
11. Establish and maintain appropriate policies, practices, and safeguards against use of the verification process for unlawful discrimination, and to ensure that U.S. citizens and authorized workers do not face discrimination with respect to hiring, firing, recruitment or referral for a fee because of citizenship status or national origin.
12. Maintain copies of any documents accepted as proof of identify and/or employment authorization for all new hires.

8.23. INSURANCE REQUIREMENTS

A. INDEMNITY, SAFETY AND INSURANCE PROVISIONS:

1. Indemnity: To the fullest extent permitted by Florida law, the Vendor/Contractor covenants, and agrees that it will indemnify and hold harmless the County and all of the County's officers, agents, and employees from any claim, loss, damage, cost, charge, attorney's fees and costs, or any other expense arising out of any act, action, neglect, or omission by Vendor/Contractor during the performance of the contract, whether direct or indirect, and whether to any person or property to which the County or said parties may be subject, except that neither the Vendor/Contractor nor any of its subcontractors, or assignees, will be liable under this section for damages arising out of injury or damage to persons or property directly caused or resulting from the sole negligence of the County or any of its officers, agents, or employees.
2. Protection of Person and Property:
 - a. The Vendor/Contractor will take all reasonable precautions for, and will be responsible for initiating, maintaining and supervising all programs relating to the safety of all

persons and property affected by, or involved in, the performance of his operations under this Contract.

- b. The Vendor/Contractor will take all reasonable precautions to prevent damage, injury or loss to: (a) all persons who may be affected by the performance of his operations, including employees; (b) all materials and equipment; and (c) all property at or surrounding the work site. In an emergency affecting the safety of persons or property, the Vendor/Contractor will act, with reasonable care and discretion, to prevent any threatened damage, injury or loss.

B. MINIMUM INSURANCE REQUIREMENTS: Vendor/Contractor shall procure, pay for and maintain at least the following insurance coverage and limits. Said insurance shall be evidenced by delivery to the County of a certificate(s) of insurance executed by the insurers listing coverage and limits, expiration dates and terms of policies and all endorsements whether or not required by the County, and listing all carriers issuing said policies. The insurance requirements shall remain in effect throughout the term of this Contract.

1. Workers' Compensation: As required by law:

a. State.....Statutory

b. APPLICABLE FEDERAL.....Statutory

c. EMPLOYER'S LIABILITY.....Minimum:

i. \$100,000.00 each accident

ii. \$100,000.00 by employee

iii. \$500,000.00 policy limit

d. Exemption per Florida Statute 440: If a Vendor/Contractor has less than three (3) employees and states that they are exempt per Florida Statute 440, they must provide an exemption certificate from the State of Florida. Otherwise, they will be required to purchase Workers' Compensation Insurance and provide a copy of Workers Compensation Insurance.

<https://www.myfloridacfo.com/Division/WC/Employer/Exemptions/>

2. General Liability: Comprehensive General Liability including, but not limited to, Independent Contractor, Contractual Premises/Operations, and Personal Injury covering the liability assumed under indemnification provisions of this Contract, with limits of liability for personal injury and/or bodily injury, including death.

a. Coverage as follows:

i. EACH OCCURRENCE.....\$1,000,000.00

ii. GENERAL AGGREGATE\$2,000,000.00

- iii. PERSONAL/ADVERTISING INJURY.....\$1,000,000.00
- iv. PRODUCTS-COMPLETED OPERATIONS AGGREGATE.....\$2,000,000.00 Per Project Aggregate (if applicable)
- b. ALSO, include in General Liability coverage for the following areas based on limits of policy, with:
 - i. FIRE DAMAGE (Any one (1) fire.....\$50,000.00
 - ii. MEDICAL EXPENSE (Any one (1) person)..... \$5,000.00
- 3. Additional Insured: Vendor/Contractor agrees to endorse Hernando County as an additional insured on the Comprehensive General Liability. The Additional Insured shall read "Hernando County Board of County Commissioners." Proof of Endorsement is required.
- 4. Waiver of Subrogation: Vendor/Contractor agrees by entering into this Contract to a Waiver of Subrogation for each required policy herein. When required by the insurer, or should a policy condition not permit Vendor/Contractor to enter into a pre-loss agreement to waive subrogation without an endorsement, then Vendor/Contractor agree to notify the insurer and request the policy be endorsed with a Waiver of Transfer of Rights of Recovery Against Others, or its equivalent. This Waiver of Subrogation requirement shall not apply to any policy, which includes a condition specifically prohibiting such an endorsement, or voids coverage should Vendor/Contractor enter into such an agreement on a pre-loss basis.
- 5. AUTOMOBILE LIABILITY: Comprehensive automobile and truck liability covering any auto, all owned autos, scheduled autos, hired autos, and non-owned autos. Coverage shall be on an "occurrence" basis. Such insurance to include coverage for loading and unloading hazards. Coverage as follows:
 - a. COMBINED SINGLE LIMIT (CSL)..... \$1,000,000.00 or:
 - i. BODILY INJURY (Per Person)..... \$1,000,000.00
 - ii. BODILY INJURY (Per Accident)..... \$1,000,000.00
 - iii. PROPERTY DAMAGE.....\$1,000,000.00
- 6. PROFESSIONAL LIABILITY (if applicable it will be noted below separately):
- 7. BUILDERS RISK INSURANCE (if applicable it will be noted below separately):
- 8. CRIME PREVENTION – BOND (if applicable it will be noted below separately):
- 9. EXCESS/UMBRELLA LIABILITY (if applicable it will be noted below separately):
- 10. POLLUTION LIABILITY (if applicable it will be noted below separately):

11. **SUBCONTRACTORS (if applicable):** All subcontractors hired by said Contractor are required to provide Hernando County Board of County Commissioners a Certificate of Insurance with the same limits required by the County as required by the Contract. All subcontractors are required to name Hernando County Board of County Commissioners as additional insured and provide a Waiver of Subrogation in regards to General Liability.
 12. **RIGHT TO REVISE OR REJECT:** County reserves the right, but not the obligation, to revise any insurance requirement, not limited to limits, coverages and endorsements, or to reject any insurance policies which fail to meet the criteria stated herein. Additionally, County reserves the right, but not the obligation, to review and reject any insurer providing coverage due of its poor financial condition or failure to operating legally.
- C. EACH INSURANCE POLICY SHALL INCLUDE THE FOLLOWING CONDITIONS BY ENDORSEMENT TO THE POLICY:
1. Vendor/Contractor agrees to provide County with a Certificate of Insurance evidencing that all coverages, limits and endorsements required herein are maintained and in full force and effect, and the Certificate of Insurance shall provide a minimum thirty (30) day endeavor to notify, when available by Vendor/Contractor's insurer. If the Vendor/Contractor receives a non-renewal or cancellation notice from an insurance carrier affording coverage required herein, or receives noticed that coverage no longer complies with the insurance requirements herein, Vendor/Contractor agrees to notify the County by email within five (5) business days with a copy of the non-renewal or cancellation notice, or written specifics as to which coverage is no longer in compliance. The Certificate Holder shall read: **Hernando County Board of County Commissioners Attention: Human Resources/Risk Department 15470 Flight Path Drive, Brooksville, Florida 34604**
- D. Companies issuing the insurance policy, or policies, shall have no recourse against the County for payment of premiums or assessments for any deductibles which all are the sole responsibility and risk of Vendor/Contractor.
- E. The term "County" or "Hernando County" shall include all authorities, boards, bureaus, commissions, divisions, departments, and offices of the County and individual members, employees and agents thereof in their official capacities, and/or while acting on behalf of Hernando County.
- F. The policy clause "Other Insurance" shall not apply to any insurance coverage currently held by County, to any such future coverage, or to County's Self-Insured Retentions of whatever nature.
- G. The Vendor/Contractor shall be required to provide a current Certificate of Insurance to the County prior to commencement of services.

- H. Bidders may, at the County's request, be required to provide proof that their firm meets the preceding insurance requirements, by submission of a Certificate Of Insurance coverage(s), prior to award of the Contract.
- I. Failure of the Owner to demand such certificates or other evidence of full compliance with these insurance requirements or failure of the Owner to identify a deficiency from evidence provided shall not be construed as a waiver of Vendor/Contractor's obligation to maintain such insurance.

8.24. INSURANCE REQUIREMENTS (continued)

BUILDERS RISK INSURANCE: Combined single limit must equal value of the construction, per project aggregate. The policy shall cover portions of the work in transit, property scaffolding, false work and temporary buildings located at the site. The policy must cover the cost of removing debris, including demolition as may be made legally necessary by the operation of any law, ordinance or regulation. The insurance required herein must be on an All Risk Form and must be written to cover all risks of physical loss or damage to the insured party and must insure at least against the perils of fire and extended coverage, theft, vandalism, malicious mischief, collapse, lightning, earthquake, flood, water damage and windstorm. If there are any deductibles applicable to the insurance required herein, Vendor/Contractor must pay any part of any loss not covered because of the operation of such deductibles. The insurance as required herein must be maintained in effect until the earliest of the following date:

- A. Date which all persons and organization that are insured under the policy agree in writing that it must be terminated;
- B. Date on which final payment of this Contract has been made by County to Vendor/Contractor;
or
- C. Date on which the insurable interests in the property of all insured other the County have ceased.
- D. Wind coverage to be included with a minimum deductible to be determined based on the project. Deductible will be a percentage based upon the total insured value.

8.25. INSURANCE REQUIREMENTS (continued)

CRIME PREVENTION – BOND: Vendor/Contractor shall procure a fiduciary bond in the amount of \$100,000.00 covering loss or theft by Vendor/Contractor, its agents, or employees, and shall procure insurance in the amount of \$10,000.00 covering loss or theft by non-employees such as by burglary or robbery for any funds or negotiable instruments under the custody or care of Vendor/Contractor that would insure to the benefit of the County.

8.26. INSURANCE REQUIREMENTS (continued)

EXCESS/UMBRELLA LIABILITY: Vendor/Contractor shall provide proof of Excess/Umbrella Liability coverage with minimum limits of \$2,000,000.00. Limits can be increased, based on Contract.

8.27. EXECUTION OF WRITTEN CONTRACT

The successful Bidder will be required to sign a written contract, in two (2) copies, which has been made a part of this bid package and identified as the Sample Construction Agreement in Questionnaire. Said written Contract will evidence in written form the agreement between the parties pursuant to the award having been therefore made by the County to this Bidder; said signing to be accomplished within ten (10) days after Notice of Award.

8.28. CONE OF SILENCE

- A. This Solicitation falls under the Hernando County Procurement Ordinance 93-16. After a bid is opened or a short list is established for an Invitation to Bid, Request for Qualification, or Request for Proposal, a Vendor/Contractor or representative as defined in the Ordinance, may not seek information or clarification or in any way contact any official or employee of the County concerning this Solicitation with the exception of the Chief Procurement Officer, County Attorney, or an individual specifically designated in this document for dissemination of information. A copy of any written communication concerning this Solicitation shall be filed with the Procurement Department and shall be made available to the public upon request. A violation of the cone of silence renders any award voidable at the discretion of the Chief Procurement Officer with approval from the Board of County Commissioners and may subject the potential Vendor/Contractor or representative to debarment. Nothing in the Ordinance prevents a Vendor/Contractor or representative from taking part in a public meeting concerning the Solicitation.
- B. All Vendors/Contractors or representatives are hereby placed on formal notice. A lobbying cone of silence period shall commence upon issuance of the Solicitation until the Board selects the successful Bidder. For procurements that do not require Board approval, the cone of silence period commences upon Solicitation issuance and concludes upon Contract award.
- C. Neither the members of the Board of County Commissioners nor candidates for County Commission, nor any employees from the Hernando County Government, Hernando County staff members, nor any members of the evaluation team are to be lobbied, either individually or collectively, concerning this project. Vendors/Contractors or representatives who intend to submit bids, or have submitted bids, for this project are hereby placed on formal notice that they are not to contact County personnel for such purposes as holding meetings of introduction, meals, or meetings relating to the selection process outside of those specifically scheduled by the County. Any such lobbying activities may cause immediate disqualification of this project.

9. SPECIAL CONDITIONS

9.1. TIME OF COMPLETION

Bidder agrees that the work will be substantially complete within days to substantial completion one hundred eighty (180) calendar days after the commencement date indicated in the Notice to Proceed and ready for final payment within days to final completion one hundred ninety-four (194) calendar days after the date indicated on the Notice to Proceed. The timeframe between substantial and final is thirty fourteen (14) calendar days. Completion time includes material ordering lead times. Materials shall not be ordered by the Vendor/Contractor until the Notice to Proceed has been issued.

9.2. STARTING THE WORK

- A. Before undertaking each part of the work, the Vendor/Contractor shall:
1. Carefully study and compare the Contract Documents and check and verify pertinent figures shown thereon and all applicable field measurements. Vendor/Contractor shall promptly report in writing to the Project Manager any conflict, error or discrepancy which the Vendor/Contractor may discover and shall obtain a written interpretation or clarification from the Project Manager before proceeding with any work affected thereby; however, Vendor/Contractor shall not be liable to County for failure to report any conflict, error or discrepancy in the Contract Documents, unless Vendor/Contractor had actual knowledge, or should reasonably have known thereof.
 2. Within ten (10) calendar days after the effective date of the Agreement (unless otherwise specified), Vendor/Contractor shall submit to the Engineer for review:
 - a. A preliminary Progress Schedule indicating the times (number of days or dates) for starting and completing the various stages of the work, including milestones specified in the Contract Documents;
 - b. A preliminary schedule of shop drawings and sample submittals which will list each required submittal and the times for submitting, reviewing, and processing such submittal; and
 - c. A preliminary Schedule of Values for all the work which will include quantities and prices of items aggregating the contract price and will subdivide the work into component parts in sufficient detail to serve as the basis for progress payments during construction. Such prices will include an appropriate amount of overhead and profit applicable to each item of work.
- B. The Vendor/Contractor will start the work within ten (10) calendar days of the official Notice to Proceed date. The Contract Time shall commence to run from the date of the Notice to Proceed.

9.3. LIQUIDATED DAMAGES

Bidders hereby agree that time is of the essence and that a precise determination of actual damages which could be incurred by the County for delay in the completion of the work provided herein would be difficult to ascertain. Accordingly the parties agree that the liquidated damages for those items of damage not otherwise provided for by the bid documents, for each and every day that the time consumed in completing the work provided for herein exceeds the time allowed in achieving substantial completion and/or final completion therefore shall be in accordance with the amount(s) set forth in the sample Construction Agreement, Article 3, Paragraph 3.03, of the contract documents (available as an attachment located in Section 15. Vendor Questionnaire, Subsection 24.3). The parties specifically agree that the liquidated damages provided herein do not constitute a penalty. The amount of liquidated damages occasioned by the Vendor/Contractor's delay will be deducted and retained out of the monies payable to the Vendor/Contractor. If not so deducted the Vendor/Contractor and sureties for the Vendor/Contractor shall be liable thereof.

9.4. INTERPRETATION AND INTENT OF THE CONTRACT DOCUMENTS

- A. It is the intent of the specifications and drawings to describe a complete project to be constructed in accordance with the Contract Documents. Any labor, documentation, services, materials, or equipment that may reasonably be inferred from the Contract Documents or from prevailing custom or trade usage as being required to produce the intended result will be provided whether or not specifically called for at no additional cost to Owner.
- B. The Contract Documents are complementary; what is called for by one (1) is as binding as if called for by all.
- C. Reference Standards:
 - 1. Reference to standards, specifications, manuals, or codes of any technical society, organization, or association, or to laws or regulations, whether such reference be specific or by implication, shall mean the standard, specification, manual, code, or laws or regulations in effect at the time of opening of bids (or on the effective date of the Agreement if there were no bids), except as may be otherwise specifically stated in the Contract Documents.
 - 2. No provision of any such standard, specification, manual or code, or any instruction of a supplier shall be effective to change the duties or responsibilities of Owner, Vendor/Contractor, or Engineer, or any of their subcontractors, consultants, agents, or employees from those set forth in the Contract Documents. No such provision or instruction shall be effective to assign to Owner, or Engineer, or any of their related entities, any duty or authority to supervise or direct the performance of the work or any duty or authority to undertake responsibility inconsistent with the provisions of the Contract Documents.
- D. If, during the performance of the work, the Vendor/Contractor discovers any conflict, error, ambiguity, or discrepancy within the Contract Documents or between the Contract Documents and any provision of any law or regulation applicable to the performance of the work or of any

standard, specification, manual or code, or of any instruction of any supplier, Vendor/Contractor shall promptly report it to Engineer in writing. Vendor/Contractor shall not proceed with the work affected thereby until an amendment or supplement to the Contract Documents has been issued. The more stringent requirements shall apply unless otherwise approved.

- E. The Vendor/Contractor shall take no advantage of any error or omission in the plans or of any discrepancy between the plans and specifications, and the professional shall make such interpretation as may be deemed necessary for the fulfillment of the intent of the plans and specifications as construed by him and his decision shall be final.
- F. Vendor/Contractor shall make reasonable efforts to identify potential changes which may enhance efficiency, reliability, serviceability or economy of operation, accelerate the construction schedule, reduce cost of construction, or otherwise enhance any benefits to Hernando County. The Vendor/Contractor, in its reasonable judgment, may propose in writing to Hernando County any such potential change, along with its proposed effect on the cost of the work or the installation schedule. Hernando County shall consider any such proposed change in good faith and may, in its sole discretion, approve in writing any such change.
- G. Reuse of Documents:
 - 1. Vendor/Contractor and any subcontractor or supplier shall not:
 - a. Have or acquire any title to or ownership rights in any of the drawings, specifications, or other documents (or copies of any thereof) prepared by or bearing the seal of Engineer or Engineer's consultants, including electronic media editions; or
 - b. Reuse any of such drawings, specifications, other documents, or copies thereof on extensions of the project or any other project without written consent of Owner and Engineer and specific written verification or adaptation by Engineer.
 - 2. The prohibition of this paragraph will survive final payment, or termination of the Contract. Nothing herein shall preclude Vendor/Contractor from retaining copies of the Contract Documents for record purposes.
- H. Electronic Data:
 - 1. Copies of data furnished by Owner or Engineer to Vendor/Contractor that may be relied upon are limited to the printed copies (also known as hard copies). Files in electronic media format of text, data, graphics, or other types are furnished only for the convenience of the receiving party. Any conclusion or information obtained or derived from such electronic files will be at the user's sole risk. If there is a discrepancy between the electronic files and the hard copies, the hard copies govern.
 - 2. Because data stored in electronic media format can deteriorate or be modified inadvertently or otherwise without authorization of the data's creator, the party receiving

- electronic files agrees that it will perform acceptance tests or procedures within sixty (60) days, after which the receiving party shall be deemed to have accepted the data thus transferred. Any errors detected within the sixty (60) day acceptance period will be corrected by the transferring party.
3. When transferring documents in electronic media format, the transferring party makes no representations as to long term compatibility, usability, or readability of documents resulting from the use of software application packages, operating systems, or computer hardware differing from those used by the data's creator.

9.5. COMPLIANCE WITH OCCUPATIONAL SAFETY AND HEALTH ACT (OSHA)

All construction practices, material, equipment, etc., as proposed and offered by Bidders must meet and conform to all OSHA requirements; the Bidder's signature upon the Bid Form in these bid documents, being by this reference considered a certification of such fact.

9.6. OWNER'S RESPONSIBILITIES AFTER AWARD

- A. Communications to Vendor/Contractor: Except as otherwise provided in these Contract Documents, Owner shall issue all communications to Vendor/Contractor through designated Authorized Owner Representative.
- B. Furnish Data: Owner shall promptly furnish the data required of Owner under the Contract Documents.
- C. Pay When Due: Owner shall make payments to Vendor/Contractor when they are due as provided in the Contract Documents.
- D. Lands and Easements; Reports and Tests: Owner's duties in respect of providing lands and easements and providing engineering surveys to establish reference points are set forth in the Contract Documents. Owner shall identify and make available to Vendor/Contractor copies of reports of explorations and tests of subsurface conditions and drawings of physical conditions in or relating to existing surface or subsurface structures at or contiguous to the site that have been utilized by the Engineer in preparing the Contract Documents.
- E. Change Orders: Owner is obligated to execute change orders as indicated in the Contract Documents.
- F. Inspections, Tests, and Approvals: Owner's responsibility in respect to certain inspections, tests, and approvals is set forth in the Contract Documents.
- G. Limitations on Owner's Responsibilities: The Owner shall not supervise, direct, or have control or authority over, nor be responsible for, Vendor/Contractor's means, methods, techniques,

sequences, or procedures of construction, or the safety precautions and programs incident thereto, or for any failure of Vendor/Contractor to comply with laws and regulations applicable to the performance of the work. Owner will not be responsible for Vendor/Contractor's failure to perform the work in accordance with the Contract Documents.

- H. Undisclosed Hazardous Environmental Condition: Owner's responsibility in respect to an undisclosed hazardous environmental condition is set forth in the Contract Documents.
- I. Evidence of Financial Arrangements: If and to the extent Owner has agreed to furnish Vendor/Contractor reasonable evidence that financial arrangements have been made to satisfy Owner's obligations under the Contract Documents, Owner's responsibility in respect thereof will be as set forth in the Contract Documents.

9.7. OWNER DESIGNATED REPRESENTATIVE'S STATUS DURING CONSTRUCTION

- A. Owner's Representative: The duties and responsibilities and the limitations of authority of the Owner's Representative during construction are set forth in the Contract Documents and will not be changed without written consent of Owner.
- B. Visits to Site:
 - 1. Owner's Designated Representative will make visits to the site at intervals appropriate to the various stages of construction as the Owner Designated Representative deems necessary in order to observe as an experienced and qualified design professional the progress that has been made and the quality of the various aspects of Vendor/Contractor's executed work. Based on information obtained during such visits and observations, the Owner Designated Representative will determine, in general, if the work is proceeding in accordance with the Contract Documents. The Owner Designated Representative will not be required to make exhaustive or continuous inspections on the site to check the quality or quantity of the work. Owner Designated Representative's efforts will be directed toward providing for Owner a greater degree of confidence that the completed work will conform generally to the Contract Documents. On the basis of such visits and observations, Owner Designated Representative will keep Owner informed of the progress of the work and will endeavor to guard Owner against defective work.
 - 2. Owner Designated Representative's visits and observations are subject to all the limitations on Owner Designated Representative's authority and responsibility set forth in paragraph titled "LIMITATIONS ON OWNER DESIGNATED REPRESENTATIVE'S AUTHORITY AND RESPONSIBILITIES". Particularly, but without limitation, during or as a result of Owner Designated Representative's visits or observations of Vendor/Contractor's work Owner Designated Representative will not supervise, direct, control, or have authority over or be responsible for Vendor/Contractor's means, methods, techniques, sequences, or procedures of construction, or the safety precautions and programs incident thereto, or for any failure

- of Vendor/Contractor to comply with laws and regulations applicable to the performance of the work.
- C. Project Representative: If Owner and Owner Designated Representative agree, Owner Designated Representative will furnish a Resident Project Representative to assist Owner Designated Representative in providing more extensive observation of the work. The authority and responsibilities of any such Resident Project Representative and assistants is provided in paragraph titled "LIMITATIONS ON OWNER DESIGNATED REPRESENTATIVE'S AUTHORITY AND RESPONSIBILITIES", and limitations on the responsibilities thereof are provided below. If Owner designates another representative or agent to represent Owner at the site who is not Engineer's consultant, agent or employee, the responsibilities and authority and limitations thereon of such other individual or entity will be as provided in the Contract Documents.
- D. Authorized Variations in Work: Owner Designated Representative may authorize minor variations in the work from the requirements of the Contract Documents which do not involve an adjustment in the contract price or the contract times and are compatible with the design concept of the completed project as a functioning whole as indicated by the Contract Documents. These may be accomplished by a field order and will be binding on Owner and also on Vendor/Contractor, who shall perform the work involved promptly. If Owner or Vendor/Contractor believes that a field order justifies an adjustment in the contract price or contract times, or both, and the parties are unable to agree on entitlement to or on the amount or extent, if any, of any such adjustment, a claim may be made therefore as provided in Section titled "CHANGES IN THE WORK; CLAIMS" paragraph entitled "CLAIMS".
- E. Rejecting Defective Work: Owner Designated Representative will have authority to reject work which Owner Designated Representative believes to be defective, or that Owner Designated Representative believes will not produce a completed project that conforms to the Contract Documents or that will prejudice the integrity of the design concept of the completed project as a functioning whole as indicated by the Contract Documents. Owner Designated Representative will also have authority to require special inspection or testing of the work as provided in Section titled "TESTS AND INSPECTIONS; CORRECTIONS, REMOVAL/ACCEPTANCE OF DEFECTIVE WORK: paragraph titled "TESTS AND INSPECTIONS", whether or not the work is fabricated, installed, or completed.
- F. Determinations for Unit Price Work: Owner Designated Representative will determine the actual quantities and classifications of unit price work performed by Vendor/Contractor. Owner Designated Representative will review with Vendor/Contractor the Owner Designated Representative's preliminary determinations on such matters before rendering a written decision thereon (by recommendation of an application for payment or otherwise). Owner Designated Representative's written decision thereon will be final and binding (except as modified by Owner Designated Representative to reflect changed factual conditions or more accurate data) upon Owner and Vendor/Contractor, subject to the provisions Section titled

"COST OF THE WORK; ALLOWANCES; UNIT PRICE WORK" paragraph titled "VENDOR/CONTRACTOR'S FEE".

G. Decisions on Requirements of Contract Documents and Acceptability of Work:

1. Owner Designated Representative will be the initial interpreter of the requirements of the Contract Documents and judge of the acceptability of the work thereunder. All matters in question and other matters between Owner and Vendor/Contractor arising prior to the date final payment is due relating to the acceptability of the work, and the interpretation of the requirements of the Contract Documents pertaining to the performance of the work, will be referred initially to Owner Designated Representative in writing within thirty (30) days of the event giving rise to the question.
2. Owner Designated Representative will, with reasonable promptness, render a written decision on the issue referred and obtain Owner's approval to issue decision. If Owner or Vendor/Contractor believes that any such decision entitles them to an adjustment in the contract price or contract times or both, a claim may be made under the provision stated in Section titled "CHANGES IN THE WORK; CLAIMS" paragraph entitled "CLAIMS".
3. Owner Designated Representative's written decision on the issue referred will be final and binding on Owner and Vendor/Contractor, subject to the provisions in paragraph titled "LIMITATIONS ON OWNER DESIGNATED REPRESENTATIVE'S AUTHORITY AND RESPONSIBILITIES".
4. When functioning as interpreter and judge under paragraph titled "DECISIONS ON REQUIREMENTS OF CONTRACT DOCUMENTS AND ACCEPTABILITY OF WORK".

H. Limitations on Owner Designated Representative's Authority and Responsibilities:

1. Neither Owner Designated Representative's authority or responsibility under this paragraph or under any other provision of the Contract Documents nor any decision made by Owner Designated Representative in good faith either to exercise or not exercise such authority or responsibility or the undertaking, exercise, or performance of any authority or responsibility by Owner Designated Representative shall create, impose, or give rise to any duty in contract, tort, or otherwise owed by Owner Designated Representative to Vendor/Contractor, any subcontractor, any supplier, any other individual or entity, or to any surety for or employee or agent of any of them.
2. Owner Designated Representative will not supervise, direct, control, or have authority over or be responsible for Vendor/Contractor's means, methods, techniques, sequences, or procedures of construction, or the safety precautions and programs incident thereto, or for any failure of Vendor/Contractor to comply with laws and regulations applicable to the performance of the work. Owner Designated Representative will not be responsible for

Vendor/Contractor's failure to perform the work in accordance with the Contract Documents.

3. Owner Designated Representative will not be responsible for the acts or omissions of Vendor/Contractor or of any subcontractor, any supplier, or of any other individual or entity performing any of the work.
4. Owner Designated Representative's review of the application for payment and accompanying documentation and all maintenance and operating instructions, schedules, guarantees, bonds, certificates of inspection, tests and approvals, and other documentation required to be delivered by Section titled "PAYMENTS TO CONTRACTOR AND COMPLETION" paragraph titled "REVIEW OF APPLICATIONS".
5. The limitations upon authority and responsibility set forth in this paragraph shall also apply to the Resident Project Representative, if any, and assistants, if any.

9.8. CONTRACTOR'S RESPONSIBILITIES

A. Supervision and Superintendence:

1. The Vendor/Contractor will supervise and direct the work efficiently and with his best skill and attention. He will be solely responsible for the means, methods, techniques, sequences and procedure of construction, unless otherwise specified. The Vendor/Contractor will be responsible to see that the finished work complies accurately with the Contract Documents.
2. The Vendor/Contractor will keep on the site at all times during its progress a competent, Resident Superintendent who shall not be replaced without written notice to the Project Manager. The superintendent will be the Vendor/Contractor's representative at the site and shall have authority to act on behalf of the Vendor/Contractor. All communications given to the superintendent shall be as binding as if given to the Vendor/Contractor.

B. Labor, Materials and Equipment:

1. The Vendor/Contractor will provide competent, suitable, qualified personnel to lay out the work and perform construction as required by the Contract Documents. He will at all times maintain good discipline and order at the site.
2. Unless otherwise specified in the Contract Documents, Vendor/Contractor shall furnish all materials, equipment, labor, transportation, construction equipment and machinery, tools, appliances, fuel, power, light, heat, telephone, water and sanitary facilities and incidentals necessary for the execution, testing, initial operation and completion of the work.
3. All materials and equipment will be new except as otherwise provided in the Contract Documents. All special warranties and guarantees required by the specifications shall expressly run to the benefit of Owner. If required by the Owner, the Vendor/Contractor will

furnish satisfactory evidence (including reports of required tests and/or purchase receipts) as to the source, kind and quality of materials and equipment furnished.

4. All materials and equipment shall be applied, installed, connected, erected, used, cleaned and conditioned in accordance with the instructions of the applicable manufacturer, supplier, fabricator or processors except as otherwise provided in the Contract Documents.

C. Progress Schedule:

1. Vendor/Contractor shall adhere to the Progress Schedule requirements established in the Contract Documents as it may be adjusted from time to time as provided below.
 - a. Vendor/Contractor shall submit to Owner Designated Representative for acceptance proposed adjustments in the Progress Schedule that will not result in changing the contract times. Such adjustments will comply with any provisions of the Contract Documents applicable thereto.
 - b. Proposed adjustments in the Progress Schedule that will change the contract times shall be submitted in accordance with the requirements stated in the Contract Documents. Adjustments in contract times may only be made by a change order.
 - c. All work of this Contract shall be scheduled and monitored by the Vendor/Contractor using the Critical Path Method (CPM). The Vendor/Contractor shall prepare the schedule for the project a minimum of two (2) weeks before starting any work and shall submit an updated schedule with each monthly pay request. The Vendor/Contractor will prepare revisions of the schedule to reflect changes in the Vendor/Contractor's plan of performance or changes in the work and submit these revisions to the Owner Designated Representative for acceptance.
 - d. The Vendor/Contractor shall prepare schedules as a time scale logic diagram and bar chart unless otherwise approved by the Owner Designated Representative. Each major and minor portion of work or operation shall be clearly identified and tied by logical sequence to the shop drawing schedule and schedule of values. All schedules shall be prepared and submitted on 11 inch by 17 inch (11" X 17") paper.

D. Concerning Subcontractors, Suppliers and Others:

1. The Vendor/Contractor will not employ any subcontractor, supplier, other person or entity, whether initially or as a replacement, against whom the Owner may have reasonable objections, nor will the Vendor/Contractor be required to employ any subcontractor, supplier, or other individual or entity, against whom the Vendor/Contractor has reasonable objection.
2. The Vendor/Contractor will not make any substitution for any subcontractor who has been accepted by the Owner, unless the Owner determines that there is good cause for doing so.

3. The Vendor/Contractor will be fully responsible for all acts and omissions of his subcontractors, suppliers, and other individuals or entities performing or furnishing any of the work just as Vendor/Contractor is responsible for Vendor/Contractor's own acts and omissions. Nothing contained in the Contract Documents:
 - a. Shall create for the benefit of any such subcontractor, supplier, or other individual or entity any contractual relationship between Owner or Owner Designated Representative and any such Subcontractor, supplier or other individual or entity, nor
 - b. Shall anything in the Contract Documents create any obligation on the part of Owner or Owner Designated Representative to pay or to see to the payment of any moneys due any such subcontractor, supplier, or other individual or entity except as may otherwise be required by laws and regulations.
4. Vendor/Contractor shall be solely responsible for scheduling and coordinating the work of subcontractors, suppliers, and other individuals or entities performing or furnishing any of the work under a direct or indirect contract with Vendor/Contractor.
5. Vendor/Contractor shall require all subcontractors, suppliers, and such other individuals or entities performing or furnishing any of the work to communicate with Owner Designated Representative through Vendor/Contractor.
6. The divisions and sections of the specifications and the identifications of any drawings shall not control Vendor/Contractor in dividing the work among subcontractors or suppliers or delineating the work to be performed by any specific trade.
7. All work performed for Vendor/Contractor by a subcontractor or supplier will be pursuant to an appropriate agreement between Vendor/Contractor and the subcontractor or supplier which specifically binds the subcontractor or supplier to the applicable terms and conditions of the Contract Documents for the benefit of Owner and Owner Designated Representative. Whenever any such agreement is with a subcontractor or supplier who is listed as an additional insured on the property insurance as provided in the Contract Documents, the agreement between the Vendor/Contractor and the subcontractor or supplier will contain provisions whereby the subcontractor or supplier waives all rights against Owner, Vendor/Contractor, and Owner Designated Representative, and all other individuals or entities identified in the Contract Documents to be listed as insureds or additional insureds (and the officers, directors, partners, employees, agents, consultants and subcontractors of each and any of them) for all losses and damages caused by, arising out of, relating to, or resulting from any of the perils or causes of loss covered by such policies and any other property insurance applicable to the work. If the insurers on any such policies require separate waiver forms to be signed by any subcontractor or supplier, Vendor/Contractor will obtain the same.

8. The Vendor/Contractor agrees to bind specifically every subcontractor to the applicable terms and conditions of the Contract Documents for the benefit of the Owner.
9. The Vendor/Contractor shall not award work valued at more than fifty percent (50%) of the contract price to subcontractor(s), without prior written approval of the Owner.

9.9. CONTRACTOR'S RESPONSIBILITIES (continued)

A. Patent Fees And Royalties:

1. Vendor/Contractor shall pay all license fees and royalties and assume all costs incident to the use in the performance of the work or the incorporation in the work of any invention, design, process, product, or device which is the subject of patent rights or copyrights held by others. If a particular invention, design, process, product, or device is specified in the Contract Documents for use in the performance of the work and if to the actual knowledge of Owner or Owner Designated Representative its use is subject to patent rights or copyrights calling for the payment of any license fee or royalty to others, the existence of such rights shall be disclosed by Owner in the Contract Documents.
2. To the fullest extent permitted by laws and regulations, Vendor/Contractor shall indemnify and hold harmless Owner and Owner Designated Representative, and the officers, directors, partners, employees, agents, consultants and subcontractors of each and any of them from and against all claims, costs, losses, and damages (including but not limited to all fees and charges of engineers, architects, attorneys, and other professionals and all court or arbitration or other dispute resolution costs) arising out of or relating to any infringement of patent rights or copyrights incident to the use in the performance of the work or resulting from the incorporation in the work of any invention, design, process, product, or device not specified in the Contract Documents.

B. Use Of Premises:

1. The Vendor/Contractor will confine his equipment, the storage of materials and equipment, and the operations of his workers to the areas permitted by law, ordinances, permits or the requirements of the Contract Documents and shall not unreasonably encumber the premises with materials or equipment.
2. The Vendor/Contractor shall confine the operation of workmen and equipment, and the storage of materials and equipment to the County's property or to other non-County property or in public right-of-way areas indicated on the contract drawings as including work to be done pursuant to the Contract Documents. In the event the Vendor/Contractor desires to have access to the project site, or perform work or operations pertaining to the Contract on, over or from non-County property adjacent to the project site, the Vendor/Contractor shall obtain written authorization to do so from the respective adjacent

property owner(s) prior to using such property. Such written authorization shall include a provision whereby the property owner agrees to hold the County harmless, and to defend the County, in the event of any liability, loss, injury, or claim incurred as a result of the Vendor/Contractors work or operations involving the use of the adjacent non-County property. The County shall be provided with a notarized, certified copy of such written authorization(s) before the Vendor/Contractor commences work or operations or use of such property in connection with work or operations pursuant to this Contract.

C. Record Documents:

1. Vendor/Contractor shall maintain in a safe place at the site one (1) record copy of all drawings, specifications, addenda, change orders, field orders, and written interpretations and clarifications in good order and annotated to show changes made during construction. These record documents together with all approved samples and a counterpart of all approved shop drawings will be available to Engineer for reference. Upon completion of the work, these record documents, samples, and shop drawings will be delivered to Engineer for Owner.
2. Record Drawings: The Engineer will prepare a set of record drawings for the project which will include the changes made in materials, equipment, locations, and dimensions of the work. Each month or as otherwise agreed, the Vendor/Contractor shall submit to the Engineer a current listing and description (written and graphic) of each change incorporated into the work since the preceding submittal.

D. Safety And Protection:

1. Vendor/Contractor shall be solely responsible for initiating, maintaining, and supervising all safety precautions and programs in connection with the work. Vendor/Contractor shall take all necessary precautions for the safety of, and shall provide the necessary protection to prevent damage, injury or loss to:
 - a. All employees on the site and other persons who may be affected by the work:
 - b. All the work and materials and equipment to be incorporated therein, whether in storage on or off the site; and
 - c. Other property at the site or adjacent thereto, including trees, shrubs, lawns, walks, pavements, roadways, structures, utilities and underground facilities not designated for removal, relocation or replacement in the course of construction.
2. Vendor/Contractor shall comply with all applicable laws and regulations relating to the safety of persons or property, or to the protection of persons or property from damage, injury, or loss; and shall erect and maintain all necessary safeguards for such safety and protection. Vendor/Contractor shall notify owners of adjacent property and of underground facilities and other utility owners when prosecution of the work may affect them, and shall

- cooperate with them in the protection, removal, relocation, and replacement of their property.
3. All damage, injury, or loss to any property referred to above; caused directly or indirectly, in whole or in part, by Vendor/Contractor, any subcontractor, supplier, or any other individual or entity directly or indirectly employed by any of them to perform any of the work, or anyone for whose acts any of them may be liable, shall be remedied by Vendor/Contractor (except damage or loss attributable to the fault of drawings or specifications or to the acts or omissions of Owner or Engineer, or anyone employed by any of them, or anyone for whose acts any of them may be liable, and not attributable, directly or indirectly, in whole or in part, to the fault or negligence of Vendor/Contractor or any subcontractor, supplier, or other individual or entity directly or indirectly employed by any of them).
 4. Vendor/Contractor's duties and responsibilities for safety and for protection of the work shall continue until such time as all the work is completed and Engineer has issued final acceptance.
 5. Vendor/Contractor shall designate a qualified and experienced safety representative at the site whose duties and responsibilities shall be the prevention of accidents and the maintaining and supervising of safety precautions and programs.
- E. Emergencies: In emergencies affecting the safety or protection of persons or the work or property at the site or adjacent thereto, Vendor/Contractor is obligated to act to prevent threatened damage, injury, or loss. Vendor/Contractor shall give Owner Designated Representative prompt written notice if Vendor/Contractor believes that any significant changes in the work or variations from the Contract Documents have been caused thereby or are required as a result thereof. If Owner Designated Representative determines that a change in the Contract Documents is required because of the action taken by Vendor/Contractor in response to such an emergency, a change order will be issued.

9.10. CONTRACTOR'S RESPONSIBILITIES (continued)

- A. Shop Drawings, Samples and Test Specimens, Additional and Special Submittals:
1. Vendor/Contractor shall submit all shop drawings, samples and test specimens, additional and special submittals to Owner Designated Representative for review and approval in accordance with the acceptable Schedule of Submittals. The Vendor/Contractor's attention is directed to the individual specification sections in these Contract Documents which may contain additional and special submittal requirements.
 - a. Shop Drawings:
 - i. Submit number of copies specified in the specifications.

- ii. Data shown on the shop drawings will be complete with respect to quantities, dimensions, specified performance and design criteria, materials, and similar data to show Owner Designated Representative the services, materials, and equipment Vendor/Contractor proposes to provide and to enable Owner Designated Representative to review the information for the limited purposes of establishing a reporting procedure and is intended for the Vendor/Contractor's convenience in organizing his work and to permit the Owner Designated Representative to monitor the Vendor/Contractor's progress and understanding of the design.
 - iii. Should the Vendor/Contractor propose any item on his field drawings, or incorporate an item into the work, and that item should subsequently prove to be defective or otherwise unsatisfactory, (regardless of the Owner Designated Representative 's preliminary review), the Vendor/Contractor shall, at his own expense, replace the item with another item that will perform satisfactorily.
 - iv. The Vendor/Contractor agrees that shop drawing submittals processed by the Owner Designated Representative do not become Contract Documents and are not change orders.
- b. Samples and Test Specimens:
- i. Submit number of samples and/or test specimens as required in the specifications. Where required in the specifications, and as determined necessary by the Owner Designated Representative, test specimens or samples of materials, appliances, and fittings to be used or offered for use in connection with the work shall be submitted to the Owner Designated Representative at the Vendor/Contractor's expense, with all cartage charges prepaid, and in such quantities and sizes as may be required for proper examination and tests to establish the quality or equality thereof, as applicable.
 - ii. Clearly identify each as to material, supplier, pertinent data such as catalog numbers, the use for which intended and other data as Owner Designated Representative may require enabling Owner Designated Representative to review the submittal for the limited purposes of establishing a reporting procedure and is intended for the Vendor/Contractor's convenience in organizing his work and to permit the Owner Designated Representative to monitor the Vendor/Contractor's progress and understanding of the design.
 - iii. All samples and test specimens shall be submitted in ample time to enable the Owner Designated Representative to make any examinations necessary, without delay to the work. The Vendor/Contractor will be held responsible for any loss of time due to his neglect or failure to deliver the required samples to the Owner Designated Representative, as specified.

- iv. The Vendor/Contractor shall submit additional samples as required by the Owner Designated Representative to ensure equality with the original approved sample and/or for determination of specification compliance.
 - v. Laboratory tests and examinations that the Owner elects to have made by an independent testing laboratory will be made at no cost to the Vendor/Contractor, except that, if a sample of any material or equipment proposed for use by the Vendor/Contractor fails to meet the specifications, the cost of testing subsequent samples shall be borne by the Vendor/Contractor.
 - vi. All tests required by the specifications to be performed by an independent laboratory shall be made by an Owner approved laboratory. Certified test results of all specified tests shall be submitted in duplicate to the Owner Designated Representative. The samples furnished and the cost for the laboratory services shall be at the expense of the Vendor/Contractor and included in the prices bid for the associated work.
 - vii. Sample items (fixtures, hardware, etc.) may be incorporated into the work upon approval, and when no longer needed by the Owner Designated Representative for reference.
- c. Submittals:
- i. All technical submittals shall be fully sufficient in detail for determination of compliance with the Contract Documents.
 - ii. Review or acceptance of substitutions, schedules, shop drawings, lists of materials, and procedures submitted or requested by the Vendor/Contractor shall not add to the Contract amount, and all additional costs which may result therefrom shall be solely the obligation of the Vendor/Contractor.
 - iii. The Owner is not precluded, by virtue of review, acceptance, or approval, from obtaining a credit for construction savings resulting from allowed concessions in the work or materials therefore.
 - iv. No equipment or material for which listings, drawings, or descriptive material is required shall be fabricated, purchased, or installed until the Owner Designated Representative has reviewed same and returned copies with stamp and signature indicating action taken.
2. Where shop drawings, samples, additional technical or special submittals are required by the Contract Documents or the Schedule of Submittals, any related work performed prior to Owner Designated Representative's review and approval of the pertinent submittal will be at the sole expense and responsibility of Vendor/Contractor.

3. Submittal Procedures:

- a. Submittals shall be addressed to the Owner Designated Representative as defined in these construction documents. Before submitting each shop drawing, sample, test specimens or other technical submittal, Vendor/Contractor shall have determined and verified:
 - i. All field measurements, quantities, dimensions, specified performance and design criteria, installation requirements, materials, catalog numbers, and similar information with respect thereto;
 - ii. The suitability of all materials with respect to intended use, fabrication, shipping, handling, storage, assembly, and installation pertaining to the performance of the work;
 - iii. All information relative to Vendor/Contractor's responsibilities for means, methods, techniques, sequences, and procedures of construction, and safety precautions and programs incident thereto; and
 - iv. Shall also have reviewed and coordinated each shop drawing or sample with other shop drawings and samples and with the requirements of the work and the Contract Documents.
- b. Each submittal shall bear a stamp or specific written certification that Vendor/Contractor has satisfied Vendor/Contractor's obligations under the Contract Documents with respect to Vendor/Contractor's review and approval of that submittal. The practice of submitting incomplete or unchecked shop drawings for the Owner Designated Representative to correct or finish will not be acceptable. Shop drawings which, in the opinion of the Owner Designated Representative, clearly indicate that they have not been checked by the Vendor/Contractor will be considered as not complying with the intent of the Contract Documents and will be returned to the Vendor/Contractor for resubmission in the proper form.
- c. With each submittal, Vendor/Contractor shall give Owner Designated Representative specific written notice of any variations, that the shop drawing or sample may have from the requirements of the Contract Documents. This notice shall be both a written communication separate from the shop drawings or sample submittal; and, in addition, by a specific notation made on each shop drawing or sample submitted to Owner Designated Representative for review and approval of each such variation.
- d. The Vendor/Contractor shall submit to the Owner Designated Representative for his review five (5) copies of shop drawings, electrical diagrams, performance data and pump curves, wiring and control diagrams, special features, interface schematic diagrams, catalog information and cuts for fabricated items and manufactured items

including structural, mechanical, electrical, plumbing, process, instrumentation and control systems and equipment furnished under this Contract. Shop drawings shall be submitted in sufficient time to allow the Owner Designated Representative not less than twenty (20) regular working days for examining the drawings.

4. Owner Designated Representative's Review:

- a. Owner Designated Representative will provide timely review of shop drawings and samples in accordance with the Schedule of Submittals acceptable to Owner Designated Representative. Owner Designated Representative's review and approval will be only to determine if the items covered by the submittals will, after installation or incorporation in the work, conform to the information given in the Contract Documents and be compatible with the design concept of the completed project as a functioning whole as indicated by the Contract Documents.
- b. Owner Designated Representative's review and approval shall not relieve Vendor/Contractor from responsibility for any variation from the requirements of the Contract Documents unless Vendor/Contractor has complied with the requirements and Owner Designated Representative has given written approval of each such variation by specific written notation thereof incorporated in or accompanying the shop drawing or sample. Owner Designated Representative's review and approval shall not relieve Vendor/Contractor from responsibility for complying with the requirements stated above.
- c. Owner Designated Representative's review and approval shall not relieve Vendor/Contractor from responsibility for any variation from the requirements of the Contract Documents unless Vendor/Contractor has complied with the requirements and Owner Designated Representative has given written approval of each such variation by specific written notation thereof incorporated in or accompanying the shop drawing or sample. Owner Designated Representative's review and approval shall not relieve Vendor/Contractor from responsibility for complying with the requirements stated above.

5. Re-submittal Procedures:

- a. Vendor/Contractor shall make corrections required by Owner Designated Representative and shall return the required number of corrected copies of shop drawings and submit, as required, new samples for review and approval. Vendor/Contractor shall direct specific attention in writing to revisions other than the corrections called for by Owner Designated Representative on previous submittals. Costs incurred by Owner Designated Representative, and/or Owner, related to review and approval of additional submittals beyond that associated with the original submittal and one (1) re-submittal will be the responsibility of the Vendor/Contractor.

6. Certificates of Compliance:

- a. A Certificate of Compliance shall be furnished for materials specified to a recognized standard or code prior to the use of any such materials in the work. The Owner Designated Representative may permit the use of certain materials or assemblies prior to sampling and testing if accompanied by a Certificate of Compliance. The certificate shall be signed by the manufacturer of the material or the manufacturer of assembled materials and shall state that the materials involved comply in all respects with the requirement of the specifications. A Certificate of Compliance shall be furnished with each lot of material delivered to the work and the lot so certified shall be clearly identified in the certificate.
- b. All materials used on the basis of a Certificate of Compliance may be sampled and tested at any time. The fact that material is used on the basis of a Certificate of Compliance shall not relieve the Vendor/Contractor of responsibility for incorporating material in the work which conforms to the requirements of the Contract Documents and any such material not conforming to such requirements will be subject to rejection whether in place or not.
- c. The Owner Designated Representative reserves the right to refuse permission for use of material on the basis of a Certificate of Compliance.
- d. The form of the Certificate of Compliance and its disposition shall be as directed by the Owner Designated Representative.

9.11. CONTRACTOR'S RESPONSIBILITIES (continued)

- A. Continuing the Work: Vendor/Contractor shall carry on the work and adhere to the Progress Schedule during all disputes or disagreements with Owner. No work shall be delayed or postponed pending resolution of any disputes or disagreements, except as permitted in Section titled "CHANGE OF CONTRACT PRICE; CHANGE OF CONTRACT TIMES" paragraph entitled "DELAYS" or as Owner and Vendor/Contractor may otherwise agree in writing.
- B. Use of Site and Other Areas:
 1. Limitation on Use of Site and Other Areas:
 - a. Vendor/Contractor shall confine construction equipment, the storage of materials and equipment, and the operations of workers to the site and other areas permitted by laws and regulations, and shall not unreasonably encumber the site and other areas with construction equipment or other materials or equipment. Vendor/Contractor shall assume full responsibility for any damage to any such land or area, or to the owner or occupant thereof, or of any adjacent land or areas resulting from the performance of the work.

- b. Should any claim be made by any such owner or occupant because of the performance of the work, Vendor/Contractor shall promptly settle with such other party by negotiation or otherwise resolve the claim by arbitration or other dispute resolution proceeding or at law.
 - c. To the fullest extent permitted by laws and regulations, Vendor/Contractor shall indemnify and hold harmless Owner and Owner Designated Representative, and the officers, directors, partners, employees, agents, consultants and subcontractors of each and any of them from and against all claims, costs, losses, and damages (including but not limited to all fees and charges of engineers, architects, attorneys, and other professionals and all court or arbitration or other dispute resolution costs) arising out of or relating to any claim or action, legal or equitable, brought by any such owner or occupant against Owner, Owner Designated Representative, or any other party indemnified hereunder to the extent caused by or based upon Vendor/Contractor's performance of the work.
 - 2. Removal of Debris During Performance of the Work: During the progress of the work Vendor/Contractor shall keep the site and other areas free from accumulations of waste materials, rubbish, and other debris. Removal and disposal of such waste materials, rubbish, and other debris shall conform to applicable laws and regulations.
 - 3. Clean Up: The Vendor/Contractor will keep the premises free from accumulations of waste materials, rubbish and other debris resulting from the work; at the completion of the work he will remove all waste materials, rubbish and debris from and about the premises as well as all tools, construction equipment and machinery, and surplus materials, and will leave the site clean and ready for occupancy by the County. The Vendor/Contractor will restore to their original condition those portions of the site not designated for alteration by the Contract Documents. If at any time during construction of this project, the Vendor/Contractor fails to clean up on a daily basis, the County may do so. All costs associated with the County's cleanup activities on behalf of the Vendor/Contractor shall be deducted from amounts due to the Vendor/Contractor. Prior to Substantial Completion of the work, Vendor/Contractor shall clean the site and the work and make it ready for utilization by Owner. At the completion of the work Vendor/Contractor shall remove from the site all tools, appliances, construction equipment and machinery, and surplus materials and shall restore to original condition all property not designated for alteration by the Contract Documents.
 - 4. Loading Structures: Vendor/Contractor shall not load nor permit any part of any structure to be loaded in any manner that will endanger the structure, nor shall Vendor/Contractor subject any part of the work or adjacent property to stresses or pressures that will endanger it.
- C. Vendor/Contractor's General Warranty and Guarantee:

1. Vendor/Contractor warrants and guarantees to Owner that all work will be in accordance with the Contract Documents and will not be defective. Owner Designated Representative and its related entities shall be entitled to rely on representation of Vendor/Contractor's warranty and guarantee. All unsatisfactory work, all faulty work, and all work not conforming to the requirements of the Contract Documents or any inspections, test or approvals shall be considered defective. All defective work, whether or not in place, may be rejected, corrected or accepted as provided in the Bid Specification.
2. Vendor/Contractor's warranty and guarantee hereunder excludes defects or damage caused by:
 - a. Abuse, modification, or improper maintenance or operation by persons other than Vendor/Contractor, subcontractors, suppliers, or any other individual or entity for whom Vendor/Contractor is responsible; or
 - b. Normal wear and tear under normal usage.
3. Vendor/Contractor's obligation to perform and complete the work in accordance with the Contract Documents shall be absolute. None of the following will constitute an acceptance of work that is not in accordance with the Contract Documents or a release of Vendor/Contractor's obligation to perform the work in accordance with the Contract Documents:
 - a. Observations by Owner Designated Representative;
 - b. Recommendation by Owner Designated Representative or payment by Owner of any progress or final payment;
 - c. The issuance of a certificate of Substantial Completion by Owner Designated Representative or any payment related thereto by Owner;
 - d. Use or occupancy of the work or any part thereof by Owner;
 - e. Any review and approval of a shop drawing or sample submittal or the issuance of a notice of acceptability by Owner Designated Representative;
 - f. Any inspection, test, or approval by others; or
 - g. Any correction of defective work by Owner.
4. The Vendor/Contractor shall provide and maintain in a neat and sanitary condition, such accommodations for the use of his employees as may be necessary to comply with the requirements of the state board of health or of the Owner Designated Representative.
5. The Vendor/Contractor shall be responsible for installing, operating and maintaining all traffic control associated with the project, including detours, advance warnings, channelization or other features, both at the immediate work site and at any outlying points

determined by the Owner to be necessary to satisfy project requirements and to maintain safe operations at the landfill. If traffic control is necessary, the Vendor/Contractor shall prepare a detailed traffic control plan. This plan shall be approved in writing by the Owner prior to implementation by the Vendor/Contractor.

D. Delegation of Professional Design Services:

1. Vendor/Contractor will not be required to provide professional design services unless such services are specifically required by the Contract Documents for a portion of the work or unless such services are required to carry out Vendor/Contractor's responsibilities for construction means, methods, techniques, sequences and procedures. Vendor/Contractor shall not be required to provide professional services in violation of applicable law.
2. If professional design services or certifications by a design professional related to systems, materials or equipment are specifically required of Vendor/Contractor by the Contract Documents, Owner and Owner Designated Representative will specify all performance and design criteria that such services must satisfy. Vendor/Contractor shall cause such services or certifications to be provided by a properly licensed professional, whose signature and seal shall appear on all drawings, calculations, specifications, certifications, shop drawings and other submittals prepared by such professional. Shop drawings and other submittals related to the work designed or certified by such professional, if prepared by others, shall bear such professional's written approval when submitted to Owner Designated Representative.
3. Owner and Owner Designated Representative shall be entitled to rely upon the adequacy, accuracy and completeness of the services, certifications or approvals performed by such design professionals, provided Owner and Owner Designated Representative have specified to Vendor/Contractor all performance and design criteria that such services must satisfy.
4. Owner Designated Representative's review and approval of design calculations and design drawings will be only for the limited purpose of checking for conformance with performance and design criteria given and the design concept expressed in the Contract Documents. Owner Designated Representative's review and approval of shop drawings and other submittals (except design calculations and design drawings) will be only for the purpose of determining if the items covered by the submittals will, after installation or incorporation in the work, conform to the information given in the Contract Documents and be compatible with the design concept of the completed project as a functioning whole as indicated by the Contract Documents.
5. Vendor/Contractor shall not be responsible for the adequacy of the performance or design criteria required by the Contract Documents.

9.12. AVAILABILITY OF LANDS; SUBSURFACE AND PHYSICAL CONDITIONS; HAZARDOUS ENVIRONMENTAL CONDITIONS; REFERENCE POINTS:

A. Availability of Lands:

1. Owner shall furnish the site. Owner shall notify Vendor/Contractor of any encumbrances or restrictions not of general application but specifically related to use of the site with which Vendor/Contractor must comply in performing the work. Owner will obtain in a timely manner and pay for easements for permanent structures or permanent changes in existing facilities. If Vendor/Contractor and Owner are unable to agree on entitlement to or on the amount or extent, if any, of any adjustment in the contract price or contract times, or both, as a result of any delay in Owner's furnishing the site or a part thereof, Vendor/Contractor may make a claim therefore as provided in the Contract Documents.
2. Upon reasonable written request, Owner shall furnish Vendor/Contractor with a current statement of record legal title and legal description of the lands upon which the work is to be performed and Owner's interest therein as necessary for giving notice of or filing a mechanic's or construction lien against such lands in accordance with applicable laws and regulations.
3. Vendor/Contractor shall provide for all additional lands and access thereto that may be required for temporary construction facilities or storage of materials and equipment.

B. Subsurface and Physical Conditions:

1. Reports and Drawings:
 - a. Those reports of explorations and tests of subsurface conditions at or contiguous to the site that Owner Designated Representative has used in preparing the Contract Documents; and
 - b. Those drawings of physical conditions in or relating to existing surface or subsurface structures at or contiguous to the site (except underground facilities) that Engineer has used in preparing the Contract Documents will be included in the Contract Documents as Attachments.
2. Limited reliance by Vendor/Contractor on technical data authorized: Vendor/Contractor may rely upon the general accuracy of the technical data contained in such reports and drawings, but such reports and drawings are not Contract Documents. Such technical data is identified in the Contract Documents. Except for such reliance on such technical data, Vendor/Contractor may not rely upon or make any claim against Owner or Engineer, or any of their related entities with respect to:

- a. The completeness of such reports and drawings for Vendor/Contractor's purposes, including, but not limited to, any aspects of the means, methods, techniques, sequences, and procedures of construction to be employed by Vendor/Contractor,
 - b. Other data, interpretations, opinions, and information contained in such reports or shown or indicated in such drawings; or
 - c. Any Vendor/Contractor interpretation of or conclusion drawn from any technical data or any such other data, interpretations, opinions, or information.
 - d.
3. Differing Subsurface or Physical Conditions:
- a. Notice: If Vendor/Contractor believes that any subsurface or physical condition at or contiguous to the site that is uncovered or revealed either:
 - i. Is of such a nature as to establish that any technical data on which Vendor/Contractor is entitled to rely as provided in Titled "UNDERGROUND FACILITIES" is materially inaccurate; or
 - ii. Is of such a nature as to require a change in the Contract Documents; or
 - iii. Differs materially from that shown or indicated in the Contract Documents; or
 - iv. Is of an unusual nature, and differs materially from conditions ordinarily encountered and generally recognized as inherent in work of the character provided for in the Contract Documents; then Vendor/Contractor shall, promptly after becoming aware thereof and before further disturbing the subsurface or physical conditions or performing any work in connection therewith, notify Owner and Owner Designated Representative in writing about such condition. Vendor/Contractor shall not further disturb such condition or perform any work in connection therewith until receipt of written order to do so.
 - b. Owner Designated Representative's Review: After receipt of written notice, Owner Designated Representative will promptly review the pertinent condition, determine the necessity of Owner's obtaining additional exploration or tests with respect thereto, and advise Owner in writing (with a copy to Vendor/Contractor) of Owner Designated Representative's findings and conclusions.
 - c. Possible Price and Times Adjustments:
 - i. The contract price or the contract times, or both, will be equitably adjusted to the extent that the existence of such differing subsurface or physical condition causes an increase or decrease in Vendor/Contractor's cost of, or time required for, performance of the work; subject, however, to the following:

- I. Such condition must meet any one (1) or more of the categories described in Section Titled "CHANGE OF CONTRACT PRICE; CHANGE OF CONTRACT TIMES" paragraph titled "DELAYS" and
 - II. With respect to work that is paid for on a unit price basis, any adjustment in contract price will be subject to the provisions of stated in the Contract Documents.
- ii. Vendor/Contractor shall not be entitled to any adjustment in the contract price or contract times if:
- I. Vendor/Contractor knew of the existence of such conditions at the time Vendor/Contractor made a final commitment to Owner with respect to contract price and contract times by the submission of a bid or becoming bound under a negotiated Contract; or
 - II. The existence of such condition could reasonably have been discovered or revealed as a result of any examination, investigation, exploration, test, or study of the site and contiguous areas required by the bidding requirements or Contract Documents to be conducted by or for Vendor/Contractor prior to Vendor/Contractor's making such final commitment; or
 - III. Vendor/Contractor failed to give the written notice as required by provisions above.
- iii. If Owner and Vendor/Contractor are unable to agree on entitlement to or on the amount or extent, if any, of any adjustment in the contract price or contract times, or both, a claim may be made therefore as provided in Contract Documents. However, Owner and Owner Designated Representative, and any of their related entities shall not be liable to Vendor/Contractor for any claims, costs, losses, or damages (including but not limited to all fees and charges of engineers, architects, attorneys, and other professionals and all court or arbitration or other dispute resolution costs) sustained by Vendor/Contractor on or in connection with any other project or anticipated project.
4. Underground Facilities:
- a. Shown or Indicated: The information and data shown or indicated in the Contract Documents with respect to existing underground facilities at or contiguous to the site is based on information and data furnished to Owner or Engineer by the owners of such underground facilities, including Owner, or by others. Unless it is otherwise expressly provided in the Bid documents:
 - i. Owner and Engineer shall not be responsible for the accuracy or completeness of any such information or data; and

- ii. The cost of all of the following will be included in the contract price, and Vendor/Contractor shall have full responsibility for:
 - I. Reviewing and checking all such information and data,
 - II. Locating all underground facilities shown or indicated in the Contract Documents,
 - III. Coordination of the work with the owners of such underground facilities, including Owner, during construction, and
 - IV. The safety and protection of all such underground facilities and repairing any damage thereto resulting from the work.
- iii. The Vendor/Contractor shall locate all existing utilities, vertical and horizontal, prior to commencement of construction and any excavation.
- b. Not Shown or Indicated:
 - i. If an underground facility is uncovered or revealed at or contiguous to the site which was not shown or indicated, or not shown or indicated with reasonable accuracy in the Contract Documents, Vendor/Contractor shall, promptly after becoming aware thereof and before further disturbing conditions affected thereby or performing any work in connection therewith, identify the owner of such underground facility and give written notice to that owner and to Owner and Engineer. Engineer will promptly review the underground facility and determine the extent, if any, to which a change is required in the Contract Documents to reflect and document the consequences of the existence or location of the underground facility. During such time, Vendor/Contractor shall be responsible for the safety and protection of such underground facility.
 - ii. If Engineer concludes that a change in the Contract Documents is required, a Change Order will be issued to reflect and document such consequences. An equitable adjustment shall be made in the contract price or contract times, or both, to the extent that they are attributable to the existence or location of any underground facility that was not shown or indicated or not shown or indicated with reasonable accuracy in the Contract Documents and that Vendor/Contractor did not know of and could not reasonably have been expected to be aware of or to have anticipated. If Owner and Vendor/Contractor are unable to agree on entitlement to or on the amount or extent, if any, of any such adjustment in contract price or contract times, Owner or Vendor/Contractor may make a claim therefore as provided in the Contract Documents.
- c. Obstructions:

- i. Any pipes, conduits, wires, mains, footings, driveways, or other structures encountered shall be carefully protected from injury or displacement. Any damage thereto shall be fully, promptly, and properly repaired by the Vendor/Contractor to the satisfaction of the Owner Designated Representative and the Owner thereof. Should it become necessary to change the position of water or gas or other pipes, sewer drains, or poles, the Engineer shall be at once notified of the locality and circumstances, and no claims for damages arising from the delay in adjusting the pipe, sewer drains or poles shall be made. Failure of the plans to show the locations, nature or extent of any existing structures or obstructions shall not be the basis of a claim for extra work. Any survey monument or bench mark which must be disturbed shall be carefully referenced before removal, and unless otherwise provided for, shall be replaced upon completion of the work by a registered land surveyor. Any survey monuments or bench markers which are disturbed shall be replaced by a Florida registered land surveyor.

9.13. AVAILABILITY OF LANDS; SUBSURFACE AND PHYSICAL CONDITIONS; HAZARDOUS ENVIRONMENTAL CONDITIONS; REFERENCE POINTS; (continued)

A. Reference Points:

1. Owner shall provide engineering surveys to establish reference points for construction which in Owner Designated Representative's judgment are necessary to enable Vendor/Contractor to proceed with the work. Vendor/Contractor shall be responsible for laying out the work, shall protect and preserve the established reference points and property monuments, and shall make no changes or relocations without the prior written approval of Owner. Vendor/Contractor shall report to Owner Designated Representative whenever any reference point or property monument is lost or destroyed or requires relocation because of necessary changes in grades or locations, and shall be responsible for the accurate replacement or relocation of such reference points or property monuments by professionally qualified personnel.
2. Vendor/Contractor will furnish all surveys and construction stakeouts unless otherwise specified. The Vendor/Contractor will provide horizontal control and bench marks or elevations for vertical control. The number and extent of such control will be designated to the Vendor/Contractor by the Owner Designated Representative prior to bid opening, upon request. It shall be the responsibility of the Vendor/Contractor to check all stakes as set by the Engineer for possible error. The Vendor/Contractor shall furnish, free of charge, all additional stakes, all templates, and other materials necessary for marking and maintaining points and lines given. The Vendor/Contractor shall be held responsible for the preservation of all stakes and marks, and if any of the stakes or marks are destroyed or disturbed, the cost of replacing them shall be charged against, and shall be deducted from the payment for

the work. The Vendor/Contractor shall be responsible for any mistakes that may be caused by their unnecessary loss or disturbance.

3. The Vendor/Contractor shall provide reasonable and necessary opportunities and facilities for setting points and making measurements. He shall not proceed until he has made timely demand upon the Owner Designated Representative for, and received from him, such points as may be necessary as the work progresses. The work shall be done in strict conformity with such points.
 - a. Alignment Markers. The markers for alignment and location information which are shown on the plans have been previously established by a Florida registered land surveyor. Monuments and other field markers consist of railroad spikes, iron pins, concrete monuments, and other markers in customary use in the area. The Vendor/Contractor shall lay out his work from these markers, and shall be responsible for all measurements in connection therewith. The Vendor/Contractor shall preserve all alignment and right-of-way markers, and shall reset or replace at his own expense, any and all which are removed, destroyed or covered up by his work. In the event that additional markers, stakes or monuments are required, or in the event that previously established markers must be replaced, the Vendor/Contractor shall employ a Florida registered land surveyor to reset or replace them.
 - b. Bench Marks. The Vendor/Contractor shall lay out his work from bench marks and elevations set by the Engineer. Bench marks and elevations set by the Engineer will be shown and explained to the Vendor/Contractor. Thereafter, these bench marks and elevations become the sole responsibility of the Vendor/Contractor, and if replacement is required, either at the request of the Vendor/Contractor or in the judgment of the Owner Designated Representative, the Vendor/Contractor shall pay for the cost of replacement. The Vendor/Contractor shall furnish, at his own expense, all templates, stakes, equipment, labor and materials as may be required in laying out any part of the work.

B. Hazardous Environmental Condition at Site:

1. Reports and Drawings: Any reports and drawings relating to a hazardous environmental condition identified at the site, if any, that have been utilized by the Engineer in the preparation of the Contract Documents will be included in the Contract Documents as Attachments under Reference Documents.
2. Limited Reliance by Vendor/Contractor on Technical Data Authorized: Vendor/Contractor may rely upon the general accuracy of the technical data contained in such reports and drawings, but such reports and drawings are not Contract Documents. Such technical data is identified in the Technical Specifications. Except for such reliance on such technical data,

Vendor/Contractor may not rely upon or make any claim against Owner or Engineer, or any of their related entities with respect to:

- a. The completeness of such reports and drawings for Vendor/Contractor's purposes, including, but not limited to, any aspects of the means, methods, techniques, sequences and procedures of construction to be employed by Vendor/Contractor and safety precautions and programs incident thereto; or
 - b. Other data, interpretations, opinions and information contained in such reports or shown or indicated in such drawings;
3. Vendor/Contractor shall not be responsible for any hazardous environmental condition uncovered or revealed at the site which was not shown or indicated in drawings or specifications or identified in the Contract Documents to be within the scope of the work. Vendor/Contractor shall be responsible for a hazardous environmental condition created with any materials brought to the site by Vendor/Contractor, subcontractors, suppliers, or anyone else for whom Vendor/Contractor is responsible.
 4. If Vendor/Contractor encounters a hazardous environmental condition or if Vendor/Contractor or anyone for whom Vendor/Contractor is responsible creates a hazardous environmental condition, Vendor/Contractor shall immediately: (i) secure or otherwise isolate such condition; (ii) stop all work in connection with such condition and in any area affected thereby; and (iii) notify Owner and Owner Designated Representative (and promptly thereafter confirm such notice in writing). Owner shall promptly consult with Owner Designated Representative concerning the necessity for Owner to retain a qualified expert to evaluate such condition or take corrective action, if any.
 5. Vendor/Contractor shall not be required to resume work in connection with such condition or in any affected area until after Owner has obtained any required permits related thereto and delivered to Vendor/Contractor written notice: (i) specifying that such condition and any affected area is or has been rendered safe for the resumption of work; or (ii) specifying any special conditions under which such work may be resumed safely. If Owner and Vendor/Contractor cannot agree as to entitlement to or on the amount or extent, if any, of any adjustment in contract price or contract times, or both, as a result of such work stoppage or such special conditions under which work is agreed to be resumed by Vendor/Contractor, either party may make a claim therefore as provided in the Contract Documents.
 6. If after receipt of such written notice Vendor/Contractor does not agree to resume such work based on a reasonable belief it is unsafe, or does not agree to resume such work under such special conditions, then Owner may order the portion of the work that is in the area affected by such condition to be deleted from the work. If Owner and Vendor/Contractor cannot agree as to entitlement to or on the amount or extent, if any, of an adjustment in

contract price or contract times as a result of deleting such portion of the work, then either party may make a claim therefore as provided in the Contract Documents. Owner may have such deleted portion of the work performed by Owner's own forces or others in accordance with Section "Other Work at the Site".

7. The provisions in this paragraph do not apply to a hazardous environmental condition uncovered or revealed at the site.

9.14. PRE-CONSTRUCTION CONFERENCE

Within fourteen (14) calendar days after the effective date of the contract, but before Vendor/Contractor starts the work at the site, a conference attended by Vendor/Contractor, Owner Designated Representative, and other County staff personnel as appropriate will be held to discuss such topics as may include, but not limited to; schedules, procedures for handling shop drawings and other submittals and for processing Applications for Payment, MOT, initiation of coordination with affected utilities, agreement upon the Notice to Proceed date, and to establish a working understanding among the parties as to the work.

9.15. INITIAL ACCEPTANCE OF SCHEDULES:

At least ten (10) days before submission of the first application for payment, a conference attended by Vendor/Contractor, Owner Designated Representative, and others as appropriate will be held to review for acceptability to Owner Designated Representative. Vendor/Contractor shall have an additional ten (10) days to make corrections and adjustments and to complete and re-submit the schedules. No progress payment shall be made to Vendor/Contractor until acceptable schedules are submitted to Owner Designated Representative.

- A. The Progress Schedule will be acceptable to Owner Designated Representative if it provides an orderly progression of the work to completion within the contract times. Such acceptance will not impose on Owner Designated Representative responsibility for the Progress Schedule, for sequencing, scheduling, or progress of the work nor interfere with or relieve Vendor/Contractor from Vendor/Contractor's full responsibility therefore.
- B. Vendor/Contractor's Schedule of Submittals will be acceptable to Owner Designated Representative if it provides a workable arrangement for reviewing and processing the required submittals.
- C. Vendor/Contractor's Schedule of Values will be acceptable to Owner Designated Representative as to form and substance if it provides a reasonable allocation of the contract price to component parts of the work.

9.16. CHANGES IN THE WORK; CLAIMS:

- A. Authorized Changes in the Work:

1. Without invalidating the Contract and without notice to any surety, Owner may, subject to written approval by Agency at any time or from time to time, order additions, deletions, or revisions in the work by a Change Order. Upon receipt of any such document, Vendor/Contractor shall promptly proceed with the work involved which will be performed under the applicable conditions of the Contract Documents (except as otherwise specifically provided).
 2. If Owner and Vendor/Contractor are unable to agree on entitlement to, or on the amount or extent, if any, of an adjustment in the contract price or contract times, or both, that should be allowed as a result of a change order, a claim may be made therefor as provided in the Paragraph titled: "CLAIMS" below.
- B. Unauthorized Changes in the Work: Vendor/Contractor shall not be entitled to an increase in the contract price or an extension of the contract times with respect to any work performed that is not required by the Contract Documents as amended, modified, or supplemented, except in the case of an emergency as stated in Paragraph titled "EMERGENCIES" above, or in the case of uncovering work as stated in Paragraph titled "UNCOVERING WORK", below.
- C. Execution of Change Orders:
1. Owner and Vendor/Contractor shall execute appropriate change orders recommended by Owner Designated Representative covering:
 - a. Changes in the work which are: (i) ordered by Owner pursuant to Paragraph titled "AUTHORIZED CHANGED IN THE WORK" above, (ii) required because of acceptance of defective work pursuant to Paragraph titled "ACCEPTANCE OF DEFECTIVE WORK", below or Owner's correction of defective work pursuant to Paragraph titled "OWNER MAY CORRECT DEFECTIVE WORK" , below or (iii) agreed to by the parties;
 - b. Changes in the contract price or contract times which are agreed to by the parties, including any undisputed sum or amount of time for work actually performed in accordance with a change order; and
 - c. Changes in the contract price or contract times which embody the substance of any written decision rendered by Owner Designated Representative pursuant to Section titled "TESTS AND INSPECTIONS: CORRECTION, REMOVAL/ACCEPTANCE OF DEFECTIVE WORK", below ; provided that, in lieu of executing any such Change Order, an appeal may be taken from any such decision in accordance with the provisions of the Contract Documents and applicable laws and regulations, but during any such appeal, Vendor/Contractor shall carry on the work and adhere to the Progress Schedule as provided in Section titled "STARTING THE WORK", above.
 2. The contract price constitutes the total compensation payable to the Vendor/Contractor for performing the work. All duties, responsibilities and obligations assigned to or undertaken

by the Vendor/Contractor shall be at his expense without change in the contract price. The Contract Price may only be changed by a change order. Any claim for an increase in the Contract Price shall be in writing and delivered to the Owner Designated Representative within fifteen (15) days of the occurrence of the event giving rise to the claim. All claims for adjustment in the contract price shall be determined by the Owner Designated Representative. Any change in the contract price shall be incorporated in a change order.

- D. Notification to Surety: If notice of any change affecting the general scope of the work or the provisions of the Contract Documents (including, but not limited to, contract price or contract times) is required by the provisions of any bond to be given to a surety, the giving of any such notice will be Vendor/Contractor's responsibility. The amount of each applicable bond will be adjusted to reflect the effect of any such change.
- E. Claims:
1. Chief Procurement Officer's Decision Required: All claims, except those waived pursuant to Paragraph titled "WAIVER OF CLAIMS", below, shall be referred to the Chief Procurement Officer for decision. A decision by the Chief Procurement Officer shall be required as a condition precedent to any exercise by Owner or Vendor/Contractor of any rights or remedies either may otherwise have under Paragraph titled "OWNER MAY CORRECT DEFECTIVE WORK", below or by laws and regulations in respect of such claims.
 2. Notice: Written notice stating the general nature of each claim shall be delivered by the claimant to the Chief Procurement Officer and the other party to the Contract promptly (but in no event later than thirty (30) days) after the start of the event giving rise thereto. The responsibility to substantiate a claim shall rest with the party making the claim. Notice of the amount or extent of the claim, with supporting data shall be delivered to the Chief Procurement Officer and the other party to the Contract within sixty (60) days after the start of such event (unless the Chief Procurement Officer allows additional time for claimant to submit additional or more accurate data in support of such claim). A claim for an adjustment in contract price shall be prepared in accordance with the provisions of Paragraph titled "CHANGE OF CONTRACT PRICE", above. A claim for an adjustment in Contract Time shall be prepared in accordance with the provisions of Paragraph titled "CHANGE OF CONTRACT TIMES". Each claim shall be accompanied by claimant's written statement that the adjustment claimed is the entire adjustment to which the claimant believes it is entitled as a result of said event. The opposing party shall submit any response to the Chief Procurement Officer and the claimant within thirty (30) days after receipt of the claimant's last submittal (unless the Chief Procurement Officer allows additional time).
 3. Chief Procurement Officer's Action: Chief Procurement Officer will review each claim and, within thirty (30) days after receipt of the last submittal of the claimant or the last submittal of the opposing party, if any, take one (1) of the following actions in writing:

- a. Deny the claim in whole or in part,
 - b. Approve the claim, or
 - c. Notify the parties that the Chief Procurement Officer is unable to resolve the claim if, in the Chief Procurement Officer's sole discretion, it would be inappropriate for the Chief Procurement Officer to do so. For purposes of further resolution of the claim, such notice shall be deemed a denial.
4. In the event that Chief Procurement Officer does not take action on a claim within said thirty (30) days, the claim shall be deemed denied.
 5. Chief Procurement Officer's written action or denial pursuant to Paragraphs 3. and 4., above will be final and binding upon Owner and Vendor/Contractor, unless Owner or Vendor/Contractor invoke the dispute resolution procedure set forth in Section titled "DISPUTE RESOLUTION" within thirty (30) days of such action or denial.
 6. No claim for an adjustment in contract price or contract times will be valid if not submitted in accordance with the provisions stated in Section titled "CHANGE OF CONTRACT PRICE; CHANGE OF CONTRACT TIMES" .

9.17. COST OF THE WORK; ALLOWANCES; UNIT PRICE WORK

A. Cost of the Work:

1. Costs Included: The term cost of the work means the sum of all costs, except those excluded according to Section titled "COSTS EXCLUDED" below, necessarily incurred and paid by Vendor/Contractor in the proper performance of the work. When the value of any work covered by a change order or when a claim for an adjustment in contract price is determined on the basis of cost of the work, the costs to be reimbursed to Vendor/Contractor will be only those additional or incremental costs required because of the change in the work or because of the event giving rise to the claim. Except as otherwise may be agreed to in writing by Owner, such costs shall be in amounts no higher than those prevailing in the locality of the project, shall include only the following items, and shall not include any of the costs itemized in Section titled "COSTS EXCLUDED".
 - a. Payroll costs for employees in the direct employ of Vendor/Contractor in the performance of the work under schedules of job classifications agreed upon by Owner and Vendor/Contractor. Such employees shall include, without limitation, superintendents, foremen, and other personnel employed full time at the site. Payroll costs for employees not employed full time on the work shall be apportioned on the basis of their time spent on the work. Payroll costs shall include, but not be limited to, salaries and wages plus the cost of fringe benefits, which shall include Social Security contributions, unemployment, excise, and payroll taxes, workers' compensation, health and retirement benefits, bonuses, sick leave, vacation and holiday pay applicable

- thereto. The expenses of performing work outside of regular working hours, on Saturday, Sunday, or legal holidays, shall be included in the above to the extent authorized by Owner.
- b. Cost of all materials and equipment furnished and incorporated in the work, including costs of transportation and storage thereof, and suppliers' field services required in connection therewith. All cash discounts shall accrue to Vendor/Contractor unless Owner deposits funds with Vendor/Contractor with which to make payments, in which case the cash discounts shall accrue to Owner. All trade discounts, rebates and refunds and returns from sale of surplus materials and equipment shall accrue to Owner, and Vendor/Contractor shall make provisions so that they may be obtained.
 - c. Payments made by Vendor/Contractor to subcontractors for work performed by subcontractors. If required by Owner, Vendor/Contractor shall obtain competitive bids from subcontractors acceptable to Owner and Vendor/Contractor and shall deliver such bids to Owner, who will then determine, with the advice of Owner Designated Representative, which bids, if any, will be acceptable. If any subcontract provides that the subcontractor is to be paid on the basis of cost of the work plus a fee, the subcontractor's cost of the work and fee shall be determined in the same manner as Vendor/Contractor's cost of the work and fee as provided in this Section titled "COST OF THE WORK".
 - d. Costs of special consultants (including but not limited to engineers, architects, testing laboratories, surveyors, attorneys, and accountants) employed for services specifically related to the work.
 - e. Supplemental costs including the following:
 - i. The proportion of necessary transportation, travel, and subsistence expenses of Vendor/Contractor's employees incurred in discharge of duties connected with the work.
 - ii. Cost, including transportation and maintenance, of all materials, supplies, equipment, machinery, appliances, office, and temporary facilities at the site, and hand tools not owned by the workers, which are consumed in the performance of the work, and cost, less market value, of such items used but not consumed which remain the property of Vendor/Contractor.
 - iii. Rentals of all construction equipment and machinery, and the parts thereof whether rented from Vendor/Contractor or others in accordance with rental agreements approved by Owner with the advice of the Owner Designated Representative, and the costs of transportation, loading, unloading, assembly, dismantling, and removal thereof. All such costs shall be in accordance with the terms of said rental

agreements. The rental of any such equipment, machinery, or parts shall cease when the use thereof is no longer necessary for the work.

- iv. Sales, consumer, use, and other similar taxes related to the work, and for which Vendor/Contractor is liable, imposed by laws and regulations.
 - v. Deposits lost for causes other than negligence of Vendor/Contractor, any subcontractor, or anyone directly or indirectly employed by any of them or for whose acts any of them may be liable, and royalty payments and fees for permits and licenses.
 - vi. Losses and damages (and related expenses) caused by damage to the work, not compensated by insurance or otherwise, sustained by Vendor/Contractor in connection with the performance of the work (except losses and damages within the deductible amounts of property insurance established in accordance with the Contract Documents), provided such losses and damages have resulted from causes other than the negligence of Vendor/Contractor, any subcontractor, or anyone directly or indirectly employed by any of them or for whose acts any of them may be liable. Such losses shall include settlements made with the written consent and approval of Owner. No such losses, damages, and expenses shall be included in the cost of the work for the purpose of determining Vendor/Contractor's fee.
 - vii. The cost of utilities, fuel, and sanitary facilities at the site.
 - viii. Minor expenses such as telegrams, long distance telephone calls, telephone service at the site, expressages, and similar petty cash items in connection with the work.
 - ix. Vendor/Contractor is required by the Contract Documents to purchase and maintain all bonds and insurance.
2. Costs Excluded: The term cost of the work shall not include any of the following items:
- a. Payroll costs and other compensation of Vendor/Contractor's officers, executives, principals (of partnerships and sole proprietorships), general managers, safety managers, engineers, architects, estimators, attorneys, auditors, accountants, purchasing and contracting agents, expeditors, timekeepers, clerks, and other personnel employed by Vendor/Contractor, whether at the site or in Vendor/Contractor's principal or branch office for general administration of the work and not specifically included in the agreed upon schedule of job classifications referred to in Paragraph 1. (in this section) or specifically covered by Paragraph 1. d. (in this section), all of which are to be considered administrative costs covered by the Vendor/Contractor's fee.
 - i. Expenses of Vendor/Contractor's principal and branch offices other than Vendor/Contractor's office at the site.

- ii. Any part of Vendor/Contractor's capital expenses, including interest on Vendor/Contractor's capital employed for the work and charges against Vendor/Contractor for delinquent payments.
 - iii. Costs due to the negligence of Vendor/Contractor, any subcontractor, or anyone directly or indirectly employed by any of them or for whose acts any of them may be liable, including but not limited to, the correction of defective work, disposal of materials or equipment wrongly supplied, and making good any damage to property.
 - iv. Other overhead or general expense costs of any kind and the costs of any item not specifically and expressly included in Paragraphs 1. and 2. (in this section).
 3. Vendor/Contractor's Fee: When all the work is performed on the basis of cost-plus, Vendor/Contractor's fee shall be determined as set forth in the Agreement. When the value of any work covered by a change order or when a claim for an adjustment in contract price is determined on the basis of cost of the work, Vendor/Contractor's fee shall be determined as set forth in Section titled: "CHANGE OF CONTRACT PRICE; CHANGE OF CONTRACT TIMES" Paragraph titled: "VENDOR/CONTRACTOR'S FEE".
 4. Documentation: Whenever the cost of the work for any purpose is to be determined pursuant to Paragraph 1.(in this section), Vendor/Contractor will establish and maintain records thereof in accordance with generally accepted accounting practices and submit in a form acceptable to Owner Designated Representative an itemized cost breakdown together with supporting data.
- B. Allowances:
 1. It is understood that Vendor/Contractor has included in the contract price all allowances so named in the Contract Documents and shall cause the work so covered to be performed for such sums and by such persons or entities as may be acceptable to Owner and Engineer.
 2. Cash Allowances:
 - a. Vendor/Contractor agrees that:
 - i. The cash allowances include the cost to Vendor/Contractor (less any applicable trade discounts) of materials and equipment required by the allowances to be delivered at the site, and all applicable taxes; and
 - ii. Vendor/Contractor's costs for unloading and handling on the site, labor, installation, overhead, profit, and other expenses contemplated for the cash allowances have been included in the Contract Price and not in the allowances, and no demand for additional payment on account of any of the foregoing will be valid.

3. Contingency Allowance: Vendor/Contractor agrees that a contingency allowance, if any, is for the sole use of Owner to cover unanticipated costs.
4. Prior to final payment, an appropriate change order will be issued as recommended by Engineer to reflect actual amounts due Vendor/Contractor on account of work covered by allowances, and the contract price shall be correspondingly adjusted.

C. Unit Price Work:

1. Where the Contract Documents provide that all or part of the work is to be unit price work, initially the contract price will be deemed to include for all unit price work an amount equal to the sum of the unit price for each separately identified item of unit price work times the estimated quantity of each item as indicated in the Agreement.
2. The estimated quantities of items of unit price work are not guaranteed and are solely for the purpose of comparison of bids and determining an initial contract price. Determinations of the actual quantities and classifications of unit price work performed by Vendor/Contractor will be made by Owner Designated Representative subject to the provisions stated in the Contract Documents.
3. Each unit price will be deemed to include an amount considered by Vendor/Contractor to be adequate to cover Vendor/Contractor's overhead and profit for each separately identified item.

9.18. CHANGE OF CONTRACT PRICE; CHANGE OF CONTRACT TIMES

Change of Contract Price:

- A. The Contract Price may only be changed by a change order. Any claim for an adjustment in the Contract Price shall be based on written notice submitted by the party making the claim to the Owner Designated Representative and the Chief Procurement Officer to the Contract in accordance with Section titled "CHANGES IN THE WORK; CLAIMS" Paragraph titled "Claims" above .
- B. The value of any work covered by a change order or of any claim for an adjustment in the Contract Price will be determined as follows:
 1. Where the work involved is covered by unit prices contained in the Contract Documents, by application of such unit prices to the quantities of the items involved (subject to the provisions stated in Section titled: "COST OF THE WORK; ALLOWANCES; UNIT PRICE WORK" Paragraph titled: "UNIT PRICE WORK"; or
 2. Where the work involved is not covered by unit prices contained in the Contract Documents, but by a mutually agreed lump sum (which may include an allowance for overhead and profit not necessarily in accordance with above Section titled: COST OF THE WORK; ALLOWANCES; UNIT PRICE WORK" Paragraph titled "CASH ALLOWANCES"); or

3. Where the work involved is not covered by unit prices contained in the Contract Documents and Agreement to a lump sum is not reached under above Section titled: "COST OF THE WORK; ALLOWANCES; UNIT PRICE WORK" Paragraph titled: "COST OF THE WORK" , on the basis of the cost of the work, plus a Vendor/Contractor's fee for overhead and profit as described in this Section, Paragraph titled "VENDOR/CONTRACTOR'S FEE", immediately below.
- C. Vendor/Contractor's Fee: The Vendor/Contractor's fee for overhead and profit shall be determined as follows:
1. A mutually acceptable fixed fee; or
 2. If a fixed fee is not agreed upon, then a fee based on the following percentages of the various portions of the cost of the work:
 - a. For costs incurred under Paragraphs B.1. and B.2. (in this section), the Vendor/Contractor's fee shall be fifteen percent (15%);
 - b. For costs incurred under Paragraph B.3. (in this section) , the Vendor/Contractor's fee shall be five percent (5%);
 - c. Where one (1) or more tiers of Sub-Contracts are on the basis of cost of the work plus a fee and no fixed fee is agreed upon, the intent of Paragraph C.2.a. above (in this section) is that the subcontractor who actually performs the work, at whatever tier, will be paid a fee of fifteen percent (15%) of the costs incurred by such subcontractor under Paragraphs B.1 and B.2. (in this section) and that any higher tier subcontractor and Vendor/Contractor will each be paid a fee of five percent (5%) of the amount paid to the next lower tier subcontractor;
 - d. No fee shall be payable on the basis of costs itemized under Section titled "COST OF THE WORK; ALLOWANCES; UNIT PRICE WORK" Paragraph titled "COST OF THE WORK", "COSTS INCLUDED" paragraph 1.A.4, 1.A.5 and 1.B.;
 - e. The amount of credit to be allowed by Vendor/Contractor to Owner for any change which results in a net decrease in cost will be the amount of the actual net decrease in cost plus a deduction in Vendor/Contractor's fee by an amount equal to five percent (5%) of such net decrease; and
 - f. When both additions and credits are involved in any one (1) change, the adjustment in Vendor/Contractor's fee shall be computed on the basis of the net change in accordance with above Paragraphs (in this section) C.2.a. through C.2.f., inclusive.
- D. In such case, the Vendor/Contractor will submit in the form prescribed by the Owner, an itemized cost breakdown together with supporting data. The amount of credit to be allowed by the Vendor/Contractor to the Owner for any such change which results in a net decrease in cost,

will be the amount of the actual net decrease as determined by the Owner. When both additions and credits are involved in any one (1) change, the combined overhead and profit shall be figured on the basis of the net decrease, if any.

9.19. CHANGE OF CONTRACT PRICE; CHANGE OF CONTRACT TIMES (continued)

Material Cost Escalation:

- A. If during the performance of this contract, the cost of materials significantly increases, through no fault of the Vendor/Contractor, the price of the contract shall be equitably adjusted by change order, by an amount reasonably necessary to cover any such significant increase in the costs of materials. As used herein, a significant cost increase shall mean any increase in cost of materials exceeding two and one half percent (2.5%) experienced by Vendor/Contractor from the date of the contract signing. Such increase in material costs shall be documented through quotes, invoices, or receipts.
- B. While the delivery of materials delays, through no fault of the Vendor/Contractor, as a result of the shortage or unavailability of the materials, Vendor/Contractor shall not be liable for any additional costs or damages associate with such delay(s).

9.20. CHANGE OF CONTRACT PRICE; CHANGE OF CONTRACT TIMES (continued)

A. Change of Contract Times:

1. The Contract Times may only be changed by a change order. Any claim for an adjustment in the Contract Times shall be based on written notice submitted by the party making the claim to the Engineer and the other party to the Contract in accordance with the provisions of Section titled " CHANGES INT HE WORK; CLAIMS" paragraph titled "CLAIMS".
2. Any adjustment of the contract times covered by a change order or any claim for an adjustment in the contract times will be determined in accordance with the provisions of this paragraph.

B. Delays:

1. Where Vendor/Contractor is prevented from completing any part of the work within the contract times due to delay beyond the control of Vendor/Contractor, the contract times will be extended in an amount equal to the time lost due to such delay if a claim is made therefore as provided in Section titled "CHANGES IN THE WORK; CLAIMS, paragraph titled "CLAIMS". Delays beyond the control of Vendor/Contractor shall include, but not be limited to, acts or neglect by Owner, acts or neglect of utility owners or other Vendor/Contractors performing other work, fires, floods, epidemics, abnormal weather conditions, or acts of God.

2. If Owner, Engineer, or other Vendor/Contractors or utility owners performing other work for Owner, or anyone for whom Owner is responsible, delays, disrupts, or interferes with the performance or progress of the work, then Vendor/Contractor shall be entitled to an equitable adjustment in the contract price or the contract times, or both.
Vendor/Contractor's entitlement to an adjustment of the contract times is conditioned on such adjustment being essential to Vendor/Contractor's ability to complete the work within the contract times.
3. If Vendor/Contractor is delayed in the performance or progress of the work by fire, flood, epidemic, abnormal weather conditions, acts of God, acts or failures to act of utility owners not under the control of Owner, or other causes not the fault of and beyond control of Owner and Vendor/Contractor, then Vendor/Contractor shall be entitled to an equitable adjustment in contract times, if such adjustment is essential to Vendor/Contractor's ability to complete the work within the Contract Times. Such an adjustment shall be Vendor/Contractor's sole and exclusive remedy for the delays described in this paragraph.
 - a. Time Extensions for Delays Caused by Weather - Extensions of Contract Time for delays caused by the effects of inclement weather are justified only when inclement weather conditions or related adverse soil conditions prevent the Contractor from productively performing controlling items of work resulting in:
 - i. The Vendor/Contractor being unable to work at least fifty percent (50%) of the normal work day on the predetermined controlling work items; or
 - ii. The Vendor/Contractor must make major repairs to work damaged by weather, providing the damage was not attributable to a failure to perform or neglect by the Contractor.
 - iii. Vendor/Contractor must submit a written notice along with their updated Progress Schedule with their monthly progress payment request. If no monthly progress payment is being submitted for the month, then a written notice within thirty (30) days after occurrence of the event(s) giving rise to the weather delays must be submitted to the Owner, Engineer or designated person.
 - b. Project Manager/Inspector - Daily reports shall be maintained for all projects by the Project Manager/Inspector. This shall include weather conditions, working conditions, erosion control, and effects of weather on major work items identified on the progress schedule and general comments as a minimum.
 - c. Project Manager/Inspector - Daily reports shall be maintained for all projects by the Project Manager/Inspector. This shall include weather conditions, working conditions, erosion control, and effects of weather on major work items identified on the progress schedule and general comments as a minimum.

- d. Weather Delays for Projects - Time extensions will be granted on a contract day per delayed day.
 - i. The Contractor provides a schedule which identifies the intended work week, thus determining the scheduled work days and the controlling items of work. The initial progress schedule must be approved and agreed to by Owner, Engineer, or designated person and Contractor's Representative prior to the notice to proceed being issued and before any work has been performed and monthly when submitted with the pay request if any changes have occurred during the reporting period. No weather delays will be recognized before the Vendor/Contractor actually begins work or attempts to begin work in accordance with the approved project work schedule. Weather delays will be granted only during the authorized contract time period.
 - ii. The Owner, Engineer or designated person shall review the request and the daily reports and determine if these delays are authorized. A written response will be given to the Contractor/Vendor within five (5) business days after receipt of the request. The Chief Procurement Officer will be provided a copy of this letter and any related correspondence.
4. Owner, Engineer and the related entities of each of them shall not be liable to Vendor/Contractor for any claims, costs, losses, or damages (including but not limited to all fees and charges of engineers, architects, attorneys, and other professionals and all court or arbitration or other dispute resolution costs) sustained by Vendor/Contractor on or in connection with any other project or anticipated project.
5. Vendor/Contractor shall not be entitled to an adjustment in contract price or contract times for delays within the control of Vendor/Contractor. Delays attributable to and within the control of a subcontractor or supplier shall be deemed to be delays within the control of Vendor/Contractor.

9.21. TESTS AND INSPECTIONS; CORRECTION, REMOVAL/ACCEPTANCE OF DEFECTIVE WORK:

- A. Notice of Defects: Prompt notice of all defective work of which Owner or Engineer has actual knowledge will be given to Vendor/Contractor. All defective work may be rejected, corrected, or accepted as provided in this Paragraph.
- B. Access to Work: Owner, Engineer, their consultants and other representatives and personnel of Owner, independent testing laboratories, and governmental agencies with jurisdictional interests will have access to the site and the work at reasonable times for their observation, inspecting, and testing. Vendor/Contractor shall provide them proper and safe conditions for

such access and advise them of Vendor/Contractor's site safety procedures and programs so that they may comply therewith as applicable.

C. Tests and Inspections:

1. Vendor/Contractor shall give Engineer timely notice of readiness of the work for all required inspections, tests, or approvals and shall cooperate with inspection and testing personnel to facilitate required inspections or tests.
2. Owner shall employ and pay for the services of an independent testing laboratory to perform all inspections, tests, or approvals required by the Contract Documents except:
 - a. For inspections, tests, or approvals covered by Paragraphs D. and E. below;
 - b. That costs incurred in connection with tests or inspections conducted pursuant to Paragraph C.2. shall be paid according to Paragraph E.; and
 - c. As otherwise specifically provided in the Contract Documents.
3. If laws or regulations of any public body having jurisdiction require any work (or part thereof) specifically to be inspected, tested, or approved by an employee or other representative of such public body, Vendor/Contractor shall assume full responsibility for arranging and obtaining such inspections, tests, or approvals, pay all costs in connection therewith, and furnish Owner Designated Representative the required certificates of inspection or approval.
4. Vendor/Contractor shall be responsible for arranging and obtaining and shall pay all costs in connection with any inspections, tests, or approvals required for Owner's and Owner Designated Representative's acceptance of materials or equipment to be incorporated in the work; or acceptance of materials, mix designs, or equipment submitted for approval prior to Vendor/Contractor's purchase thereof for incorporation in the work. Such inspections, tests, or approvals shall be performed by organizations acceptable to Owner and Owner Designated Representative.
5. If any work (or the work of others) that is to be inspected, tested, or approved is covered by Vendor/Contractor without written concurrence of Owner Designated Representative, it must, if requested by Owner Designated Representative, be uncovered for observation.
6. Uncovering work as provided in Paragraph D. shall be at Vendor/Contractor's expense unless Vendor/Contractor has given Engineer timely notice of Vendor/Contractor's intention to cover the same and Engineer has not acted with reasonable promptness in response to such notice.
7. Periodic inspections will be held throughout the work at the discretion of the Owner and Engineer to verify progress and compliance to Contract Documents, pay requests and general quality control.

8. Pre-final inspections are held for the purpose of substantiating completion of the work and preparing a punch-list of any deficiencies or corrections to be made. Pre-finals should be made with a representative of the Vendor/Contractor, Owner Designated Representative and Owner.
9. Final inspections will be held prior to acceptance in order to verify that all corrections and/or deficiencies have been performed or resolved and such inspection shall be mandatory prior to approval of final pay request. Finals shall be made with a representative of the Vendor/Contractor, Engineer and Owner.

D. Uncovering Work:

1. If any work is covered contrary to the written request of Owner Designated Representative, it must, if requested by Owner Designated Representative, be uncovered for Owner Designated Representative's observation and replaced at Vendor/Contractor's expense.
2. If Owner Designated Representative considers it necessary or advisable that covered work be observed by Owner Designated Representative or inspected or tested by others, Vendor/Contractor, at Owner Designated Representative's request, shall uncover, expose, or otherwise make available for observation, inspection, or testing as Owner Designated Representative may require, that portion of the work in question, furnishing all necessary labor, material, and equipment.
3. If it is found that the uncovered work is defective, Vendor/Contractor shall pay all claims, costs, losses, and damages (including but not limited to all fees and charges of engineers, architects, attorneys, and other professionals and all court or arbitration or other dispute resolution costs) arising out of or relating to such uncovering, exposure, observation, inspection, and testing, and of satisfactory replacement or reconstruction (including but not limited to all costs of repair or replacement of work of others); and Owner shall be entitled to an appropriate decrease in the contract price. If the parties are unable to agree as to the amount thereof, Owner may make a claim therefore as provided in Section titled "CHANGES IN THE WORK; CLAIMS" paragraph titled "CLAIMS".
4. If, the uncovered work is not found to be defective, and there are no related inspection requirements in the contract documents, Vendor/Contractor shall be allowed an increase in the contract price or an extension of the contract times, or both, directly attributable to such uncovering, exposure, observation, inspection, testing, replacement, and reconstruction. If the parties are unable to agree as to the amount or extent thereof, Vendor/Contractor may make a claim therefore as provided in Section titled "CHANGES IN THE WORK; CLAIMS" paragraph titled "CLAIMS".

- E. Owner Designated Representative May Stop the Work: If the work is defective, or Vendor/Contractor fails to supply sufficient skilled workers or suitable materials or equipment, or fails to perform the work in such a way that the completed work will conform to the contract

documents, Owner may order Vendor/Contractor to stop the work, or any portion thereof, until the cause for such order has been eliminated; however, this right of Owner to stop the work shall not give rise to any duty on the part of Owner to exercise this right for the benefit of Vendor/Contractor, any subcontractor, any supplier, any other individual or entity, or any surety for, or employee or agent of any of them.

F. Correction or Removal of Defective Work:

1. Promptly after receipt of notice, Vendor/Contractor shall correct all defective work, whether or not fabricated, installed, or completed, or, if the work has been rejected by Owner Designated Representative, remove it from the project and replace it with work that is not defective. Vendor/Contractor shall pay all claims, costs, losses, and damages (including but not limited to all fees and charges of engineers, architects, attorneys, and other professionals and all court or arbitration or other dispute resolution costs) arising out of or relating to such correction or removal (including but not limited to all costs of repair or replacement of work of others).
2. When correcting defective work under the terms of this paragraph or the paragraph below, Vendor/Contractor shall take no action that would void or otherwise impair Owner's special warranty and guarantee, if any, on said work.

G. Correction Period:

1. If within one (1) year after the date of substantial completion (or such longer period of time as may be prescribed by the terms of any applicable special guarantee required by the Contract Documents) or by any specific provision of the contract documents, any work is found to be defective, or if the repair of any damages to the land or areas made available for Vendor/Contractor's use by Owner or permitted by laws and regulations as contemplated in the Contract Documents is found to be defective, Vendor/Contractor shall promptly, without cost to Owner and in accordance with Owner's written instructions:
 - a. Repair such defective land or areas; or
 - b. Correct such defective work; or
 - c. If the defective work has been rejected by Owner, remove it from the project and replace it with work that is not defective, and
 - d. Satisfactorily correct or repair or remove and replace any damage to other work, to the work of others or other land or areas resulting therefrom.
2. If Vendor/Contractor does not promptly comply with the terms of Owner's written instructions, or in an emergency where delay would cause serious risk of loss or damage, Owner may have the defective work corrected or repaired or may have the rejected work removed and replaced. All claims, costs, losses, and damages (including but not limited to all

- fees and charges of engineers, architects, attorneys, and other professionals and all court or arbitration or other dispute resolution costs) arising out of or relating to such correction or repair or such removal and replacement (including but not limited to all costs of repair or replacement of work of others) will be paid by Vendor/Contractor.
3. In special circumstances where a particular item of equipment is placed in continuous service before Substantial Completion of all the work, the correction period for that item may start to run from an earlier date if so provided in the specifications.
 4. Where defective work (and damage to other work resulting therefrom) has been corrected or removed and replaced under above paragraph F, the correction period hereunder with respect to such work will be extended for an additional period of one (1) year after such correction or removal and replacement has been satisfactorily completed.
 5. Vendor/Contractor's obligations under above paragraph F. are in addition to any other obligation or warranty. The provisions of Paragraph F. shall not be construed as a substitute for or a waiver of the provisions of any applicable statute of limitation or repose.
- H. Acceptance of Defective Work: If, instead of requiring correction or removal and replacement of defective work, Owner (and, prior to Owner Designated Representative's recommendation of final payment, Owner Designated Representative) prefers to accept it, Owner may do so. Vendor/Contractor shall pay all claims, costs, losses, and damages (including but not limited to all fees and charges of engineers, architects, attorneys, and other professionals and all court or arbitration or other dispute resolution costs) attributable to Owner's evaluation of and determination to accept such defective work (such costs to be approved by Owner Designated Representative as to reasonableness) and the diminished value of the work to the extent not otherwise paid by Vendor/Contractor pursuant to this sentence. If any such acceptance occurs prior to Owner Designated Representative's recommendation of final payment, a change order will be issued incorporating the necessary revisions in the contract documents with respect to the work, and Owner shall be entitled to an appropriate decrease in the contract price, reflecting the diminished value of work so accepted. If the parties are unable to agree as to the amount thereof, Owner may make a claim therefore as provided in Section titled "CHANGES IN THE WORK; CLAIMS", paragraph titled "CLAIMS". If the acceptance occurs after such recommendation, an appropriate amount will be paid by Vendor/Contractor to Owner.
- I. Owner May Correct Defective Work:
1. If Vendor/Contractor fails within a reasonable time after written notice from Owner Designated Representative to correct defective work or to remove and replace rejected work as required by Owner Designated Representative in accordance with Paragraph F., or if Vendor/Contractor fails to perform the work in accordance with the contract documents, or if Vendor/Contractor fails to comply with any other provision of the Contract Documents,

- Owner may, after seven (7) days written notice to Vendor/Contractor, correct or remedy any such deficiency.
2. In exercising the rights and remedies under this paragraph, Owner shall proceed expeditiously. In connection with such corrective or remedial action, Owner may exclude Vendor/Contractor from all or part of the site, take possession of all or part of the work and suspend Vendor/Contractor's services related thereto, take possession of Vendor/Contractor's tools, appliances, construction equipment and machinery at the site, and incorporate in the work all materials and equipment stored at the site or for which Owner has paid Vendor/Contractor but which are stored elsewhere. Vendor/Contractor shall allow Owner, Owner's representatives, agents and employees, Owner's other Vendor/Contractors, and Engineer and Engineer's consultants access to the site to enable Owner to exercise the rights and remedies under this paragraph.
 3. All claims, costs, losses, and damages (including but not limited to all fees and charges of engineers, architects, attorneys, and other professionals and all court or arbitration or other dispute resolution costs) incurred or sustained by Owner in exercising the rights and remedies under Paragraph I. will be charged against Vendor/Contractor, and a change order will be issued incorporating the necessary revisions in the Contract Documents with respect to the work; and Owner shall be entitled to an appropriate decrease in the contract price. If the parties are unable to agree as to the amount of the adjustment, Owner may make a claim therefore as provided in Section titled "CHANGES IN THE WORK; CLAIMS", paragraph titled "CLAIMS. Such claims, costs, losses and damages will include but not be limited to all costs of repair, or replacement of work of others destroyed or damaged by correction, removal, or replacement of Vendor/Contractor's defective work.
 4. Vendor/Contractor shall not be allowed an extension of the contract times because of any delay in the performance of the work attributable to the exercise by Owner of Owner's rights and remedies under Paragraph I.

9.22. PAYMENTS TO CONTRACTOR AND COMPLETION

- A. Schedule of Values: The Schedule of Values established as provided in Section titled "STARTING THE WORK", paragraph A. 2. c. will serve as the basis for progress payments and will be incorporated into a form of application for payment acceptable to Owner Designated Representative. Progress payments on account of unit price work will be based on the number of units completed.
- B. Progress Payments:
 1. Application for Payments:

- a. At least twenty (20) business days before the date established in the Agreement for each progress payment (but not more often than once a month), Vendor/Contractor shall submit to Owner Designated Representative for review an application for payment filled out and signed by vendor/contractor covering the work completed as of the date of the application and accompanied by such supporting documentation as is required by the contract documents. If payment is requested on the basis of materials and equipment not incorporated in the work but delivered and suitably stored at the site or at another location agreed to in writing, the application for payment shall also be accompanied by a bill of sale, invoice, or other documentation warranting that Owner has received the materials and equipment all of which must be satisfactory to Owner.
 - b. Beginning with the second application for payment, each application shall include an affidavit of Vendor/Contractor stating that all previous progress payments received on account of the work have been applied on account to discharge Vendor/Contractor's legitimate obligations associated with prior applications for payment.
 - c. The amount of retainage with respect to progress payments will be as stipulated in Article 5.02 of the construction agreement.
 - d. All progress payments will be subject to withholding and payment of retainage as specified under the provisions of Ch. 218.735, F.S. (current version) and as stipulated in the Contract Agreement attached herein. Payment requests will be processed within the time periods established by applicable provisions of the Florida Prompt Payment Act, Part VII, Ch. 218.735, F.S (current version).
2. Review of Applications:
- a. Owner Designated Representative will, within five (5) business days after receipt of each application for payment, either indicate in writing a recommendation of payment and present the application to Owner or return the application to Vendor/Contractor indicating in writing Owner Designated Representative's reasons for refusing to recommend payment. In the latter case, Vendor/Contractor may make the necessary corrections and resubmit the application.
 - b. Owner Designated Representative's recommendation of any payment requested in an application for payment will constitute a representation by Owner Designated Representative to Owner, based on Owner Designated Representative's observations on the site of the executed work as an experienced and qualified design professional and on Owner Designated Representative's review of the application for payment and the accompanying data and schedules, that to the best of Owner Designated Representative's knowledge, information and belief:
 - i. The work has progressed to the point indicated;

- ii. The quality of the work is generally in accordance with the Contract Documents (subject to an evaluation of the work as a functioning whole prior to or upon substantial completion, to the results of any subsequent tests called for in the Contract Documents, to a final determination of quantities and classifications for unit price work under above Section titled: "COST OF THE WORK; ALLOWANCES; UNIT PRICE WORK" ,, and to any other qualifications stated in the recommendation); and
 - iii. The conditions precedent to Vendor/Contractor's being entitled to such payment appear to have been fulfilled in so far as it is Owner Designated Representative's responsibility to observe the work.
- c. By recommending any such payment Owner Designated Representative will not thereby be deemed to have represented that:
 - i. Inspections made to check the quality or the quantity of the work as it has been performed have been exhaustive, extended to every aspect of the work in progress, or involved detailed inspections of the work beyond the responsibilities specifically assigned to Owner Designated Representative in the Contract Documents; or
 - ii. That there may not be other matters or issues between the parties that might entitle Vendor/Contractor to be paid additionally by Owner or entitle Owner to withhold payment to Vendor/Contractor.
- d. Neither Owner Designated Representative's review of Vendor/Contractor's work for the purposes of recommending payments nor Owner Designated Representative's recommendation of any payment, including final payment, will impose responsibility on Owner Designated Representative:
 - i. To supervise, direct, or control the work, or
 - ii. For the means, methods, techniques, sequences, or procedures of construction, or the safety precautions and programs incident thereto, or
 - iii. For Vendor/Contractor's failure to comply with laws and regulations applicable to Vendor/Contractor's performance of the work, or
 - iv. To make any examination to ascertain how or for what purposes Vendor/Contractor has used the moneys paid on account of the contract price, or
 - v. To determine that title to any of the work, materials, or equipment has passed to Owner free and clear of any liens.
- e. Owner Designated Representative may refuse to recommend the whole or any part of any payment if, in Owner Designated Representative's opinion, it would be incorrect to make the representations to Owner stated in Paragraph 2.b., above. Owner Designated

Representative may also refuse to recommend any such payment or, because of subsequently discovered evidence or the results of subsequent inspections or tests, revise or revoke any such payment recommendation previously made, to such extent as may be necessary in Owner Designated Representative's opinion to protect Owner from loss because:

- i. The work is defective, or completed work has been damaged, requiring correction or replacement;
 - ii. The contract price has been reduced by change orders;
 - iii. Owner has been required to correct defective work or complete work in accordance with above Paragraph titled "Owner May Correct Defective Work" in Section titled: "TESTS AND INSPECTIONS; CORRECTION, REMOVAL/ACCEPTANCE OF DEFECTIVE WORK"; or
 - iv. Owner Designated Representative has actual knowledge of the occurrence of any of the events enumerated in below Paragraph titled "Owner May Terminate for Cause: " in Section titled: "TERMINATION AND SUSPENSION OF WORK".
3. Payment Becomes Due: The application for payment, and all of the required Federal and State submittals, with the Owner Designated Representative's recommendations will be presented to the Owner for consideration. If the Owner finds the application for payment acceptable, the recommended amount, less any reduction under the provisions of Paragraph B. 2. (in this section), will become due twenty-five (25) business days after the application for payment is presented to the Owner, and the Owner will make payment to the Vendor/Contractor.
4. Payment to Vendor/Contractor by Electronic Payment Solution: ACH (Direct Deposit): If the Vendor/Contractor is enrolled in the County's ACH electronic payment solution, all payments will be made using the direct deposit which may or may not include a pre-note transaction. The Vendor/Contractor's bank account information will remain confidential to the extent provided by law and necessary to make direct deposit payments. Once the County has approved payment, an electronic remittance advice will be sent to the Vendor/Contractor via e-mail.
5. Reduction in Payment:
- a. Owner may refuse to make payment of the full amount recommended by Owner Designated Representative because:
 - i. Claims have been made against Owner on account of Vendor/Contractor's performance or furnishing of the work;

- ii. Liens have been filed in connection with the work, except where Vendor/Contractor has delivered a specific bond satisfactory to Owner to secure the satisfaction and discharge of such liens;
 - iii. The Vendor/Contractor's performance or furnishing of the work is inconsistent with funding agency requirements;
 - iv. There are other items entitling Owner to a set off against the amount recommended; or
 - v. Owner has actual knowledge of the occurrence of any of the events enumerated in Paragraphs B. 2. e. i. through B. 2. e. iii. (in this section) or below Paragraph titled "Owner May Terminate for Cause" in Section titled: "TERMINATION AND SUSPENSION OF WORK."
- b. If Owner refuses to make payment of the full amount recommended by Owner Designated Representative, Owner will (in no case more than twenty (20) business days after receipt and twenty-five (25) business days for payment) give Vendor/Contractor immediate written notice (with a copy to Engineer) stating the reasons for such action and promptly pay Vendor/Contractor any amount remaining after deduction of the amount so withheld. Owner shall promptly pay Vendor/Contractor the amount so withheld, or any adjustment thereto agreed to by Owner and Vendor/Contractor, when Vendor/Contractor corrects to Owner's satisfaction the reasons for such action.
 - c. If it is subsequently determined that Owner's refusal of payment was not justified, the amount wrongfully withheld shall be treated as an amount due as determined by Paragraph B. 3. (in this section).
 - d. No payments will be made that would deplete the retainage, place in escrow any funds that are required for retainage, or invest the retainage for the benefit of the Vendor/Contractor.
- C. Vendor/Contractor's Warranty of Title:
- 1. Vendor/Contractor warrants and guarantees that title to all work, materials, and equipment covered by any application for payment, whether incorporated in the project or not, will pass to Owner prior to the making of the application for payment, free and clear of all liens, claims, security interests and encumbrances; and that no work, materials or equipment covered by an application for payment will have been acquired by the Vendor/Contractor or by any other person performing the work at the site or furnishing materials and equipment for the project subject to an Agreement under which an interest therein or encumbrance thereon is retained by the seller or otherwise imposed by the Vendor/Contractor or such other person.

2. In compliance with the above and as verification of the Vendor/Contractor's compliance with applicable provisions of the Florida Prompt Payment Act, Part VII, Ch. 218.735, F.S. (current version), concerning payment to subcontractors and suppliers, the Vendor/Contractor, in addition to any other payment provisions set in this contract, shall prior to submission of the second application for payment, produce for the Owner evidence, in the form of releases of lien or subcontractor(s)/suppliers affidavits of payment received, that all subcontractors and suppliers have been paid any sum or sums then due within the time periods so specified. This reporting process shall be repeated following each succeeding payment to the Vendor/Contractor throughout the life of the Contract. A failure on the part of the Vendor/Contractor to provide the releases as required herein shall result in further progress or partial payments being withheld until the releases or payment affidavits are provided.

D. Partial Utilization:

1. Prior to Substantial Completion of all the work, Owner may use or occupy any substantially completed part of the work which has specifically been identified in the Contract Documents, or which Owner, Owner Designated Representative, and Vendor/Contractor agree constitutes a separately functioning and usable part of the work that can be used by Owner for its intended purpose without significant interference with Vendor/Contractor's performance of the remainder of the work, subject to the following conditions.
 - a. Owner at any time may request Vendor/Contractor in writing to permit Owner to use or occupy any such part of the work which Owner believes to be ready for its intended use and substantially complete. If and when Vendor/Contractor agrees that such part of the work is substantially complete, Vendor/Contractor will certify to Owner and Owner Designated Representative that such part of the work is substantially complete and request Owner Designated Representative to issue a certificate of substantial completion for that part of the work.
 - b. Vendor/Contractor at any time may notify Owner and Owner Designated Representative in writing that Vendor/Contractor considers any such part of the work ready for its intended use and is thus substantially complete and may request Owner Designated Representative to issue a certificate of substantial completion for that part of the work.
 - c. Within a reasonable time after either such request, Owner, Vendor/Contractor, and Owner Designated Representative shall make an inspection of that part of the work to determine its status of completion. If Owner Designated Representative does not consider that part of the work to be substantially complete, Owner Designated Representative will notify Owner and Vendor/Contractor in writing giving the reasons therefore. If Owner Designated Representative considers that part of the work to be substantially complete, the provisions stated herein will apply with respect to

certification of Substantial Completion of that part of the work and the division of responsibility in respect thereof and access thereto.

- d. No use or occupancy or separate operation of part of the work may occur prior to compliance with the requirements of the contract documents regarding property insurance.

E. Substantial Completion:

1. When Vendor/Contractor considers the entire work ready for its intended use Vendor/Contractor shall notify Owner and Owner Designated Representative in writing that the entire work is substantially complete (except for items specifically listed by Vendor/Contractor as incomplete) and request that the Owner issue a certificate of substantial completion.
2. Promptly after Vendor/Contractor's notification, Owner, Agency, Vendor/Contractor, and Owner Designated Representative shall make a pre-final inspection of the work to determine the status of completion. If Owner Designated Representative does not consider the work substantially complete, Owner Designated Representative will notify Vendor/Contractor in writing giving the reasons therefore.
3. If the Owner Designated Representative considers the work substantially complete, Owner Designated Representative will deliver to Owner a tentative certificate of substantial completion which shall fix the date of substantial completion. there shall be attached to the certificate a tentative list of items to be completed or corrected before final payment. Owner shall have seven (7) days after receipt of the tentative certificate during which to make written objection to Owner Designated Representative as to any provisions of the certificate or attached list. If, after considering such objections, Owner Designated Representative concludes that the work is not substantially complete, Owner Designated Representative will within fourteen (14) days after submission of the tentative certificate to Owner notify Vendor/Contractor in writing, stating the reasons therefore. If, after consideration of Owner's objections, Owner Designated Representative considers the work substantially complete, Owner Designated Representative will within said fourteen (14) days execute and deliver to Owner and Vendor/Contractor a definitive certificate of substantial completion (with a revised tentative list of items to be completed or corrected) reflecting such changes from the tentative certificate as Owner Designated Representative believes justified after consideration of any objections from Owner.
4. At the time of delivery of the tentative certificate of Substantial Completion, Owner Designated Representative will deliver to Owner and Vendor/Contractor a written recommendation as to division of responsibilities pending final payment between Owner and Vendor/Contractor with respect to security, operation, safety, and protection of the work, maintenance, heat, utilities, insurance, and warranties and guarantees. Unless Owner

and Vendor/Contractor agree otherwise in writing and so inform Owner Designated Representative in writing prior to Owner Designated Representative's issuing the definitive certificate of substantial completion, Owner Designated Representative's aforesaid recommendation will be binding on Owner and Vendor/Contractor until final payment.

5. Owner shall have the right to exclude Vendor/Contractor from the site after the date of Substantial Completion subject to allowing Vendor/Contractor reasonable access to complete or correct items on the tentative list.
- F. Final Inspection: Upon written notice from Vendor/Contractor that the entire work or an agreed portion thereof is complete, Owner Designated Representative will promptly make a final inspection with Owner, Agency, and Vendor/Contractor and will notify Vendor/Contractor in writing of all particulars in which this inspection reveals that the work is incomplete or defective. Vendor/Contractor shall immediately take such measures as are necessary to complete such work or remedy such deficiencies.

9.23. PAYMENTS TO CONTRACTOR AND COMPLETION (continued)

A. Final Payment:

1. Application for Payment:

- a. After Vendor/Contractor has, in the opinion of Owner Designated Representative, satisfactorily completed all corrections identified during the final inspection and has delivered, in accordance with the contract documents, all maintenance and operating instructions, schedules, guarantees, bonds, certificates or other evidence of insurance certificates of inspection, marked up record documents, and other documents, Vendor/Contractor may make application for final payment following the procedure for progress payments.
- b. The final application for payment shall be accompanied (except as previously delivered) by:
 - i. All documentation called for in the Contract Documents, including but not limited to the evidence of insurance required by above Section titled: "INSURANCE REQUIREMENTS" ;
 - ii. Consent of the surety, if any, to final payment;
 - iii. A list of all claims against Owner that Vendor/Contractor believes are unsettled; and
 - iv. Complete and legally effective releases or waivers (satisfactory to Owner) of all lien rights arising out of or liens filed in connection with the work.
- c. In lieu of the releases or waivers of liens specified in above Paragraph A. 1. b. iv. and as approved by Owner, Vendor/Contractor may furnish receipts or releases in full and an affidavit of Vendor/Contractor that: (i) the releases and receipts include all labor,

services, material, and equipment for which a lien could be filed; and (ii) all payrolls, material and equipment bills, and other indebtedness connected with the work for which Owner or Owner's property might in any way be responsible have been paid or otherwise satisfied. If any subcontractor or supplier fails to furnish such a release or receipt in full, Vendor/Contractor may furnish a bond or other collateral satisfactory to Owner to indemnify Owner against any lien.

2. Owner Designated Representative's Review of Application and Acceptance:

- a. If, on the basis of Owner Designated Representative's observation of the work during construction and final inspection, and Owner Designated Representative's review of the final application for payment and accompanying documentation as required by the Contract Documents, Owner Designated Representative is satisfied that the work has been completed and Vendor/Contractor's other obligations under the Contract Documents have been fulfilled, Owner Designated Representative will, within ten (10) days after receipt of the final application for payment, indicate in writing Owner Designated Representative's recommendation of payment and present the application for payment to Owner for payment. At the same time Owner Designated Representative will also give written notice to Owner and Vendor/Contractor that the work is acceptable to the provisions as described in above Paragraph A titled "Final Payment" (in this section) . Otherwise, Owner Designated Representative will return the application for payment to Vendor/Contractor, indicating in writing the reasons for refusing to recommend final payment, in which case Vendor/Contractor shall make the necessary corrections and resubmit the application for payment.

3. Payment Becomes Due: After the presentation to Owner of the application for payment and accompanying documentation to include all of the required Federal and State submittals, the Owner will, within the time periods established by applicable provisions of the Florida Prompt Payment Act, Part VII, Ch. 218.735, F.S. (current version), pay the Vendor/Contractor the amount recommended by Owner Designated Representative, less any sum Owner is entitled to set off against Owner Designated Representative's recommendation, including but not limited to liquidated damages.

- B. Final Completion Delayed: If, through no fault of Vendor/Contractor, final completion of the work is significantly delayed, and if owner designated representative so confirms, owner shall, upon receipt of vendor/contractor's final application for payment (for work fully completed and accepted) and recommendation of Owner Designated Representative, and without terminating the Contract, make payment of the balance due for that portion of the work fully completed and accepted. If the remaining balance to be held by Owner for work not fully completed or corrected is less than the retainage stipulated in the Agreement, and if bonds have been furnished as required in above Section titled "PERFORMANCE AND PAYMENT BOND", the written consent of the surety to the payment of the balance due for that portion of the work

fully completed and accepted shall be submitted by Vendor/Contractor to Owner Designated Representative with the application for such payment. Such payment shall be made under the terms and conditions governing final payment, except that it shall not constitute a waiver of claims. The remaining balance of any sum included in the final application for payment but held by Owner for work not fully completed and accepted will become due when the work is fully completed and accepted.

- C. Waiver of Claims: The making and acceptance of final payment will constitute:
1. A waiver of all claims by Owner against Vendor/Contractor, except claims arising from unsettled liens, from defective work appearing after final inspection pursuant to above Section titled "TESTS AND INSPECTIONS; CORRECTION, REMOVAL/ACCEPTANCE OF DEFECTIVE WORK", paragraph titled "CORRECTION OR REMOVAL OF DEFECTIVE WORK", from failure to comply with the contract documents or the terms of any special guarantees specified therein, or from Vendor/Contractor's continuing obligations under the contract documents; and
 2. A waiver of all claims by Vendor/Contractor against Owner other than those previously made in accordance with the requirements herein and expressly acknowledged by Owner in writing as still unsettled.
- D. Vendor/Contractor's Continuing Obligation: The Vendor/Contractor's obligation to perform the work and complete the work in accordance with the Contract Documents shall be absolute. Neither approval of any progress or final payment by the County, the issuance of Certificate of Completion, any payment by the County to the Vendor/Contractor under the contract documents, any use or occupancy of the work or any part thereof by the County, any act of acceptance by the County, any failure to do so, nor any correction of defective work by the County shall constitute an acceptance of work not in accordance with the contract documents.
1. Contract Closeout:
 - a. Pre-final and Final Inspections:
 - i. Upon completion of work, Vendor/Contractor shall submit written certification that the Contract Documents have been reviewed, the work has been inspected by the Vendor/Contractor, and that the work is substantially complete in accordance with the contract document and ready for Engineer/Owner Designated Representative's inspection.
 - ii. At this time the representatives of the Vendor/Contractor, Engineer/Owner Designated Representative's and Owner shall make a pre-final/substantial completion inspection with reasonable promptness. If the work is complete or defective, Engineer/Owner Designated Representative will notify the Contractor to remedy these deficiencies by insurance of a pre-final punch-list.

- iii. Upon written notification from the Vendor/Contractor of substantial complete of the pre-final punch list items, the Engineer/Owner Designated Representative will coordinate the re-inspection of the work by conducting a final inspection. Representatives of the Contract, Engineer, and Owner Designated Representative shall be present for the final inspection.
- iv. Vendor/Contractor shall submit the final signed and sealed As-Built drawings ten (10) days prior to the final inspection and provide all other submittals to the Engineer/Owner Designated Representative's that are required.
- b. Project Record Documents: The Vendor/Contractor shall maintain on site, one (1) set of the following record documents; recording actual revisions of the work commensurate with the construction progress:
 - i. Contract Drawings
 - ii. Specifications
 - iii. Addenda
 - iv. Change Orders and other modification to the Contract
 - v. Reviewed (and approved) Shop Drawings and Product Data
 - vi. Permits
- c. Closeout Submittals: When the Engineer/Owner Designated Representative's has determined that the work is acceptable under the Contract Documents, and the contract is fully performed, the Vendor/Contractor shall prepare and submit his final applicable for payment to the Engineer/Owner Designated Representative's with the following:
 - i. Contractor's Lien Waiver in the full amount of the contract sum.
 - ii. Lien waivers from all subcontractors and material suppliers who have furnished for the work under contract with the Contactor or subcontractor. The lien waivers shall be in the full amount of the Contract involved.
 - iii. Consent of Surety to final payment.
 - iv. Evidence of compliance with governing authorities.
 - v. Certifications of inspections from all required agencies and departments, as needed.
 - vi. Warranties and Maintenance Bond.
 - vii. Confirmation from Florida Department of Environmental Protection the National Pollution Discharge Elimination System Notice of Termination (NOT) has been filed.

- viii. Any outstanding documentation and/or reports necessary to insure compliance with FDOT requirements.
- ix. As-Built documents prepared in accordance with the contract documents and signed and sealed by a professional surveyor and mapper, registered in the State of Florida and all other requirements as set forth in the contract documents.

9.24. TERMINATION AND SUSPENSION OF WORK

A. Termination for Default:

1. The County may, by written notice to the Vendor/Contractor, terminate this Contract for default in whole or in part (delivery orders, if applicable) if the Vendor/Contractor fails to:
 - a. Provide products or services that comply with the specifications herein or fails to meet the County's performance standards.
 - b. Deliver the supplies or to perform the services within the time specified in this Contract or any extension.
 - c. Make progress so as to endanger performance of this Contract.
 - d. Perform any of the other provisions of this Contract.
2. Prior to termination for default, the County will provide adequate written notice to the (Vendor/Contractor/Consultant) through the Chief Procurement Officer, Procurement Department, affording him/her the opportunity to cure the deficiencies or to submit a specific plan to resolve the deficiencies within ten (10) days (or the period specified in the notice) after receipt of the notice. Failure to adequately cure the deficiency shall result in termination action. Such termination may also result in suspension or debarment of the Vendor/Contractor in accordance with the County's Procurement Ordinance. The Vendor/Contractor and its sureties (if any) shall be liable for any damage to the County resulting from the Vendor/Contractor's default of the contract. This liability includes any increased costs incurred by the County in completing contract performance.
3. In the event of termination by the County for any cause, the Vendor/Contractor will have, in no event, any claim against the County for lost profits or compensation for lost opportunities. After a receipt of a termination notice and except as otherwise directed by the County the Vendor/Contractor shall:
 - a. Stop work on the date and to the extent specified.
 - b. Terminate and settle all orders and subcontracts relating to the performance of the terminated work.
 - c. Transfer all work in process, completed work, and other materials related to the terminated work as directed by the County.

- d. Continue and complete all parts of that work that have not been terminated.
4. If the Vendor/Contractor's failure to perform the Contract arises from causes beyond the control and without the fault or negligence of the Vendor/Contractor, the Contract shall not be terminated for default. Examples of such causes include (1) acts of God or the public enemy, (2) acts of a government in its sovereign capacity, (3) fires, (4) floods, (5) epidemics, (6) strikes and (7) unusually severe weather.
- B. Termination for Convenience: The County, by written notice, may terminate this Contract, in whole or in part, when it is in the County's interest. If this Contract is terminated, the County shall be liable only for goods or services delivered and accepted. The county notice of termination may provide the Vendor/Contractor thirty (30) days prior notice before it becomes effective. A termination for convenience may apply to individual delivery orders, purchase orders or to the Contract in its entirety.
- C. Vendor/Contractor May Stop Work or Terminate:
1. If, through no act or fault of Vendor/Contractor, (i) the work is suspended for more than ninety (90) consecutive days by Owner or under an order of court or other public authority, or (ii) Engineer fails to act on any application for payment within thirty (30) days after it is submitted, or (iii) Owner fails for thirty (30) days to pay Vendor/Contractor any sum finally determined to be due, then Vendor/Contractor may, upon seven (7) days written notice to Owner and Engineer, and provided Owner or Engineer do not remedy such suspension or failure within that time, terminate the Contract and recover from Owner.
 2. In lieu of terminating the Contract and without prejudice to any other right or remedy, if Engineer has failed to act on an application for payment within thirty (30) days after it is submitted, or Owner has failed for thirty (30) days to pay Vendor/Contractor any sum finally determined to be due, Vendor/Contractor may, seven (7) days after written notice to Owner and Engineer, stop the work until payment is made of all such amounts due Vendor/Contractor, including interest thereon. The provisions of this paragraph are not intended to preclude Vendor/Contractor from making a claim as described in above Section titled "CHANGES IN THE WORK; CLAIMS", paragraph titled "Claims", for an adjustment in contract price or contract times or otherwise for expenses or damage directly attributable to Vendor/Contractor's stopping the work as permitted by this paragraph.
- D. Owner May Suspend Work: Owner may suspend work at any time and without cause, for a period of not more than ninety (90) consecutive days by notice in writing to Vendor/Contractor and Engineer which will fix the date on which work will be resumed. Vendor/Contractor shall resume the work on the date so fixed. Vendor/Contractor shall be granted an adjustment in the contract price or an extension of the contract times, or both, directly attributable to any such suspension if Vendor/Contractor makes a claim therefore as provided in above Section titled: "CHANGES IN THE WORK; CLAIMS".

E. Owner May Terminate for Cause:

1. The occurrence of any one (1) or more of the following events will justify termination for cause:
 - a. Vendor/Contractor's persistent failure to perform the work in accordance with the Contract Documents (including, but not limited to, failure to supply sufficient skilled workers or suitable materials or equipment or failure to adhere to the Progress Schedule established under above Section titled "STARTING THE WORK" Paragraph A. 2. a. as adjusted from time to time pursuant to above Section titled "CONTRACTOR'S RESPONSIBILITY" Paragraph titled "Progress Schedule";
 - b. Vendor/Contractor's disregard of laws or regulations of any public body having jurisdiction;
 - c. Vendor/Contractor's disregard of the authority of Engineer; or
 - d. Vendor/Contractor's violation in any substantial way of any provisions of the Contract Documents.
2. If one (1) or more of the events identified in above Paragraph E. 1. occur, Owner may, after giving Vendor/Contractor (and surety) seven (7) days written notice of its intent to terminate the services of Vendor/Contractor:
 - a. In exercising the rights and remedies under above Section titled "TESTS AND INSPECTIONS; CORRECTION, REMOVAL/ACCEPTANCE OF DEFECTIVE WORK" Paragraph titled "Owner May Correct Defective Work", Owner shall proceed expeditiously. In connection with such corrective or remedial action, Owner may exclude Vendor/Contractor from all or part of the site (without liability to Vendor/Contractor for trespass or conversion), take possession of all or part of the work and suspend Vendor/Contractor's services related thereto, take possession of Vendor/Contractor's tools, appliances, construction equipment and machinery at the site, and incorporate in the work all materials and equipment stored at the site or for which Owner has paid Vendor/Contractor but which are stored elsewhere. Vendor/Contractor shall allow Owner, Owner's representatives, agents and employees, Owner's other Vendor/Contractors, and Engineer and Engineer's consultants access to the site to enable Owner to exercise the rights and remedies under above Section titled "TESTS AND INSPECTIONS; CORRECTION, REMOVAL/ACCEPTANCE OF DEFECTIVE WORK" Paragraph titled "Owner May Correct Defective Work".
 - b. Complete the work as Owner may deem expedient.
3. If Owner proceeds as provided in Paragraph E. 2 above, Vendor/Contractor shall not be entitled to receive any further payment until the work is completed. If the unpaid balance of the contract price exceeds all claims, costs, losses, and damages (including but not limited to

all fees and charges of engineers, architects, attorneys, and other professionals and all court or arbitration or other dispute resolution costs) sustained by Owner arising out of or relating to completing the work, such excess will be paid to Vendor/Contractor. If such claims, costs, losses, and damages exceed such unpaid balance, Vendor/Contractor shall pay the difference to Owner. Such claims, costs, losses, and damages incurred by Owner will be reviewed by Engineer as to their reasonableness and, when so approved by Engineer, incorporated in a change order. When exercising any rights or remedies under this paragraph Owner shall not be required to obtain the lowest price for the work performed.

4. Notwithstanding above Paragraphs E. 2. and E. 3., Vendor/Contractor's services will not be terminated if Vendor/Contractor begins within seven (7) days of receipt of notice of intent to terminate to correct its failure to perform and proceeds diligently to cure such failure within no more than thirty (30) days of receipt of said notice.
5. Where Vendor/Contractor's services have been so terminated by Owner, the termination will not affect any rights or remedies of Owner against Vendor/Contractor then existing or which may thereafter accrue. Any retention or payment of moneys due Vendor/Contractor by Owner will not release Vendor/Contractor from liability.
6. If and to the extent that Vendor/Contractor has provided a Performance Bond under the provisions of above section, titled: "PERFORMANCE AND PAYMENT BOND", the termination procedures of that bond shall supersede the provisions of above Paragraphs E. 2. and E. 3.

F. Litigation and Remedies:

1. Should the Owner be temporarily prohibited or enjoined from proceeding with the work herein contemplated, the Vendor/Contractor shall not be entitled to any claim or damages, or otherwise, nor may the Vendor/Contractor withdraw from the Contract except by and with the consent of the Owner. The Vendor/Contractor shall, however, be entitled to an extension of time for completion of the work equal to the time of such interruption or delay as determined and certified by the Owner Designated Representative.
2. If the Owner is permanently prohibited or enjoined from proceeding with the work herein contemplated, the Owner may terminate this Contract and pay the Vendor/Contractor a sum equal to all expenses legitimately incurred by him in connection with this work, plus ten percent (10%) of such expenses, less an amount equal to the sum of all partial payments previously made to the Vendor/Contractor. The sum thus computed shall be paid to the Vendor/Contractor within thirty (30) days after the Owner shall have terminated this Contract and the payment of said sum shall be payment in full for any and all liquidated damages for the termination of this Contract and shall constitute full settlement of all claims in connection with this Contract.

9.25. DISPUTE RESOLUTION

- A. Owner and Vendor/Contractor may mutually request mediation of any claim submitted to the Owner for a decision as provided in above Section titled "CHANGES IN THE WORK; CLAIMS:" Paragraph entitled "Claims" before such decision becomes final and binding. The mediation will be governed by the Construction Industry Mediation Rules of the American Arbitration Association in effect as of the effective date of the Agreement. The request for mediation shall be submitted in writing to the American Arbitration Association. Timely submission of the request shall stay the effect as described in said "Claims" Paragraph .
- B. Owner and Vendor/Contractor shall participate in the mediation process in good faith. The process shall be concluded within sixty (60) days of filing of the request. The date of termination of the mediation shall be determined by application of the mediation rules referenced above.
- C. If the claim is not resolved by mediation, Chief Procurement Officer's action or denial pursuant to above Section entitled "CHANGES IN THE WORK; CLAIMS" Paragraph titled "Execution of Change Orders" paragraph C. or Paragraph Titled "Notification of Surety" Paragraph D. shall become final and binding thirty (30) days after termination of the mediation unless, within that time period, Owner or Vendor/Contractor:
 1. Agrees with the other party to submit the claim to another dispute resolution process, or
 2. Gives written notice to the other party of their intent to submit the claim to a court of competent jurisdiction.

9.26. MISCELLANEOUS

- A. Giving Notice:
 1. Whenever any provision of the Contract Documents requires the giving of written notice, it will be deemed to have been validly given if:
 - a. Delivered in person to the individual or to a member of the firm or to an officer of the corporation for whom it is intended, or
 - b. Delivered at or sent by registered or certified mail, postage prepaid, to the last business address known to the giver of the notice.
- B. Computation of Times: When any period of time is referred to in the Contract Documents by days, it will be computed to exclude the first and include the last day of such period. If the last day of any such period falls on a Saturday or Sunday or on a day made a legal holiday by the law of the applicable jurisdiction, such day will be omitted from the computation.
- C. Cumulative Remedies: The duties and obligations imposed by these Contract Documents and the rights and remedies available hereunder to the parties hereto are in addition to, and are not to be construed in any way as a limitation of, any rights and remedies available to any or all of them which are otherwise imposed or available by laws or regulations, by special warranty or

guarantee, or by other provisions of the Contract Documents. The provisions of this paragraph will be as effective as if repeated specifically in the Contract Documents in connection with each particular duty, obligation, right, and remedy to which they apply.

- D. Survival of Obligations: All representations, indemnifications, warranties, and guarantees made in, required by, or given in accordance with the Contract Documents, as well as all continuing obligations indicated in the Contract Documents, will survive final payment, completion, and acceptance of the work or termination or completion of the Contract or termination of the services of Vendor/Contractor.
- E. Headings: Article and paragraph headings are inserted for convenience only and do not constitute parts of these Contract Documents.
- F. Specification and Drawings Furnished by the Owner: All specifications, drawings and copies thereof furnished by the Owner shall remain its property. They shall not be used on another project and, with the exception of those sets which have been signed in connection with the execution of the Agreement, shall be returned to the Owner upon completion of the project.
- G. Laws and Ordinances: The Contract Documents shall be governed by the laws of the State of Florida and the ordinances of Hernando County.
- H. Vehicle Licensing: All prime Vendor/Contractors, including their subs, must obtain a temporary vehicle license for each and every out-of-state vehicle, personal or business (including trailers) that will be operating on-site. The cost shall be borne by the Vendor/Contractor. You must present evidence of title to the Tax Collector's Office to obtain the required temporary licenses.
- I. Handicapped Non-discrimination: The Vendor/Contractor will not discriminate against any employee or applicant for employment because he or she is handicapped in regards to any position for which the employee or applicant for employment is qualified.

9.27. OTHER WORK AT THE SITE

OTHER WORK AT THE SITE:

- A. Related Work at Site:
 - 1. Owner may perform other work related to the project at the site with Owner's employees, or via other direct contracts therefore, or have other work performed by utility owners. If such other work is not noted in the Contract Documents, then:
 - a. Written notice thereof will be given to Vendor/Contractor prior to starting any such other work; and
 - b. If Owner and Vendor/Contractor are unable to agree on entitlement to or on the amount or extent, if any, of any adjustment in the contract price or contract times that should be allowed as a result of such other work, a claim may be made therefore as

provided in above Section titled: "CHANGES IN THE WORK; CLAIMS" Paragraph titled: "Claims".

2. Vendor/Contractor shall afford other Vendor/Contractors who are a party to such a direct contract, each utility owner and Owner, if Owner is performing other work with Owner's employees, proper and safe access to the site, a reasonable opportunity for the introduction and storage of materials and equipment and the execution of such other work and shall properly coordinate the work with theirs. Vendor/Contractor shall do all cutting, fitting, and patching of the work that may be required to properly connect or otherwise make its several parts come together and properly integrate with such other work. Vendor/Contractor shall not endanger any work of others by cutting, excavating, or otherwise altering their work and will only cut or alter their work with the written consent of Owner Designated Representative and the others whose work will be affected. The duties and responsibilities of Vendor/Contractor under this paragraph are for the benefit of such utility owners and other Vendor/Contractors to the extent that there are comparable provisions for the benefit of Vendor/Contractor in said direct contracts between Owner and such utility owners and other Vendor/Contractors.
3. If the proper execution or results of any part of Vendor/Contractor's work depends upon work performed by others under this section titled "OTHER WORK AT THE SITE", Vendor/Contractor shall inspect such other work and promptly report to Owner Designated Representative in writing any delays, defects, or deficiencies in such other work that render it unavailable or unsuitable for the proper execution and results of Vendor/Contractor's work. Vendor/Contractor's failure to so report will constitute an acceptance of such other work as fit and proper for integration with Vendor/Contractor's work except for latent defects and deficiencies in such other work.

B. Coordination:

1. If Owner intends to contract with others for the performance of other work on the project at the site, the following will be set forth in the Contract Documents:
 - a. The individual or entity who will have authority and responsibility for coordination of the activities among the various Vendor/Contractors will be identified;
 - b. The specific matters to be covered by such authority and responsibility will be itemized; and
2. Unless otherwise provided in the Contract Documents, Owner shall have sole authority and responsibility for such coordination.

9.28. MATERIAL SAFETY DATA SHEETS

MATERIAL SAFETY DATA SHEETS:

- A. In accordance with Florida Emergency Planning and Community Right-to-Know Act, Chapter 252, Part II, Florida Statutes (Current Edition), it is the seller's duty to advise Hernando County if a product is a listed toxic substance and to provide a material safety data sheet (MSDS) at the time of delivery. Vendor/Contractors must comply with this procedure along with the Federal Emergency Planning and Community Right-to-Know Act (42 U.S.C. Ch 116 (Current Edition)) and the Federal Hazard Communications Standards (29CFR sec.1910.1200) all other applicable laws.

9.29. TRENCH SAFETY ACT

Bidder shall be solely responsible for complying with the Florida Trench Safety Act as established under 553.60 through 553.64, Florida Statutes (current version), and under the OSHA excavation safety standards as established under 29 CFR 1926.650 (Sub-Part P) as amended. All costs associated with complying with these requirements shall be included in the bid. The Trench Safety Act Compliance Form attached in Questionnaire, must be submitted with the bid.

9.30. SCRUTINIZED COMPANIES Pursuant to Florida Statute 287.135 And 215.473 (Current Edition)

Vendor/Contractor must certify that the company is not participating in a boycott of Israel. Vendor/Contractor must also certify that Vendor/Contractor is not on the Scrutinized Companies that Boycott Israel List, not on the Scrutinized Companies with Activities in Sudan List, and not on the Scrutinized Companies with Activities in the Iran Petroleum Energy Sector List, or has been engaged in business operations in Cuba or Syria. Subject to limited exceptions provided in State law, the County will not contract for the provision of goods or services with any scrutinized company referred to above. Vendor/Contractor must submit the certification form included as an attachment to this Solicitation. Submitting a false certification shall be deemed a material breach of contract. The County shall provide notice, in writing, to the Vendor/Contractor of the County's determination concerning the false certification. The Vendor/Contractor shall have five (5) days from receipt of notice to refute the false certification allegation. If such false certification is discovered during the active contract term, the Vendor/Contractor shall have ninety (90) days following receipt of the notice to respond in writing and demonstrate that the determination of false certification was made in error. If the Vendor/Contractor does not demonstrate that the County's determination of false certification was made in error, then the County shall have the right to terminate the contract and seek civil remedies pursuant to Section 287.135, Florida Statutes (Current Edition), as amended from time to time.

10. SUPPLEMENTARY CONDITIONS FOR FEDERAL/STATE GRANT REQUIREMENTS

10.1. MANDATORY DISCLOSURE

These disclosures are required by State law, as indicated, and apply when this Agreement includes State funding; and by Federal law, as indicated, and apply when the Agreement includes a Federal award.

- A. Convicted Vendors. Vendor/Consultant hereby certifies that neither it, nor any person or affiliate of Vendor/Consultant, has been convicted of a Public Entity Crime as defined in section 287.133, F.S., nor placed on the convicted vendor list. Vendor/Consultant shall have a continuing obligation to disclose, to Hernando County, in writing, if they, or their subcontractor, are on the convicted vendors list maintained by the Florida Department of Management Services pursuant to Section 287.133(3)(d), F.S.
1. Convicted Vendor List. Pursuant to Subsection 287.133(2)(a), F.S., a person or affiliate who has been placed on the convicted vendor list following a conviction for a public entity crime may not be awarded or perform work as a Vendor/Consultant, supplier, subcontractor or consultant under a contract with any public entity and may not transact business with any public entity in excess of the threshold amount provided in Section 287.017, F.S., for Category Two for a period of thirty-six (36) months from the date of being placed on the convicted vendor list. The State of Florida, Department of Management Services, Division of State Purchasing provides listings for convicted, suspended, discriminatory and federal excluded parties, as well as the vendor complaint list at:
https://www.dms.myflorida.com/business_operations/state_purchasing/state_agency_resources/vendor_registration_and_vendor_lists
 2. Notice of Conviction of Public Entity Crime. Any person must notify the Department of Management Services and Hernando County, in writing, within thirty (30) days after conviction of a public entity crime applicable to that person or an affiliate of that person as defined in Section 287.133, F.S.
- B. Discriminatory Vendors. Vendor/Consultant shall disclose to Hernando County, in writing, if they, or their subcontractor, are on the Discriminatory Vendor List maintained by the Florida Department of Management Services pursuant to Section 287.134(3)(d), F.S. "An entity or affiliate who has been placed on the discriminatory vendor list may not submit a bid, proposal, or reply on a contract to provide any goods or services to a public entity; may not submit a bid, proposal, or reply on a contract with a public entity for the construction or repair of a public building or public work; may not submit bids, proposals, or replies on leases of real property to a public entity; may not be awarded or perform work as a contractor, supplier, subcontractor, or consultant under a contract with any public entity; and may not transact business with any public entity." Section 287.134(2)(a), F.S. Vendor/Consultant has a continuing duty to disclose to Hernando County whether they appear on the discriminatory vendor list.

- C. **Prompt Disclosure of Litigation, Investigations, Arbitration, or Administrative Proceedings.** Throughout the term of the Agreement, the Vendor/Consultant has a continuing duty to promptly disclose to Hernando County's Grant Manager, in writing, upon occurrence, all civil or criminal litigation, investigations, arbitration, or administrative proceedings (Proceedings) relating to or affecting the Vendor/Consultant's ability to perform under this agreement. If the existence of such Proceeding causes Hernando County concern that the Vendor/Consultant's ability or willingness to perform the Agreement is jeopardized, the Vendor/Consultant may be required to provide Hernando County with reasonable assurances to demonstrate that: a.) the Vendor/Consultant will be able to perform the Agreement in accordance with its terms and conditions; and, b.) Vendor/Consultant and/or its employees or agents have not and will not engage in conduct in performing services for Hernando County which is similar in nature to the conduct alleged in such Proceeding.
- D. **Certain Violations of Federal Criminal Law.** If this agreement includes a Federal award, then in accordance with Section 200.113,, OMB Uniform Guidance (2 CFR 200), Vendor/Consultant must disclose, in a timely manner, in writing to Hernando County all violations of Federal criminal law involving fraud, bribery, or gratuity violations potentially affecting the Federal award.

10.2. RECORD KEEPING REQUIREMENTS

State Access to Vendor/Consultant Books, Documents, Papers, and Records. The Vendor/Consultant shall allow Hernando County, the Chief Financial Officer of the State of Florida, the Auditor General of the State of Florida, the Florida Office of Program Policy Analysis and Government Accountability or authorized representatives of the state or federal government to have access to any of the Vendor/Contractor's books, documents, papers, and records, including electronic storage media, as they may relate to this Agreement, for the purposes of conducting audits or examinations or making excerpts or transcriptions. Audit and record keeping requirements shall be included in all subcontracts.

10.3. FEDERAL COMPLIANCE

As applicable, Vendor/Contractor shall comply with all federal laws, rules, and regulations, including but not limited to:

- A. **Clean Air Act and Water Pollution Control Act.** All applicable standards, orders, or requirements issued under the Clean Air Act (42 U.S.C. 7401-7671q), and the Water Pollution Control Act (33 U.S.C. 1251-1387, as amended).
- B. **Lacey Act**, 16 U.S.C 3371-3378. This Act prohibits trade in wildlife, fish and plants have been illegally taken, possessed, transported or sold.
- C. **Magnuson-Stevens Fishery Conservation and Management Act**, 16 U.S.C. 1801-1884. This Act governs marine fisheries in Federal waters.
- D. **Migratory Bird Treaty Act**, 16 U.S.C. 703-712. The Act prohibits anyone, unless permitted, to pursue, hunt, take, capture, kill, attempt to take, capture or kill, possess, offer for sale, sell, offer to purchase, deliver for shipment, ship, cause to be shipped, deliver for transportation,

transport, cause to be transported, carry or cause to be carried by any means whatsoever, receive for shipment, transport of carriage, or export, at any time, or in any manner, any migratory bird, or any part, nest, or egg of such bird.

- E. **Endangered Species Act**, 16 U.S.C. 1531, et seq. The Act provides a program for the conservation of threatened and endangered plants and animals and the habitat in which they are found. The Act also prohibits any action that cause a "taking" of any listed species of endangered fish or wildlife. Also, generally prohibited are the import, export, interstate, and foreign commerce of listed species.

10.4. CONTRACT RELATED PROCUREMENT

- A. **PRIDE**In accordance with Section 946.515(6), F.S., if a product or service required for the PRIDE. In accordance with Section 946.515(6), F.S., if a product or service required for the performance of this Contract is certified by or is available from Prison Rehabilitative Industries and Diversified Enterprises, Inc. (PRIDE) and has been approved in accordance with Subsection 946.515(2), F.S., the following statement applies:
1. It is expressly understood and agreed that any articles which are the subject of, or required to carry out, this contract shall be purchased from [PRIDE] in the same manner and under the same procedures set forth in Subsections 946.515(2) and (4), F.S.; and for purposes of this contract the person, firm or other business entity carrying out the provisions of this contract shall be deemed to be substituted for this agency insofar as dealings with such corporation are concerned.
 2. The above clause is not applicable to subcontractors unless otherwise required by law. Additional information about PRIDE and the products it offers is available at <http://www.pride-enterprises.org>.
- B. **Respect of Florida**. In accordance with Subsection 413.036(3), F.S., if a product or service required for the performance of this Contract is on the procurement list established pursuant to Subsection 413.035(2), F.S., the following statement applies:
1. It is expressly understood and agreed that any articles that are the subject of, or required to carry out, this contract shall be purchased from a nonprofit agency for the blind or for the severely handicapped that is qualified pursuant to Chapter 413, F.S., in the same manner and under the same procedures set forth in Subsections 413.036(1) and (2), F.S.; and for purposes of this contract, the person, firm or other business entity carrying out the provisions of this contract shall be deemed to be substituted for the state agency insofar as dealings with such qualified nonprofit agency are concerned.
 2. Additional information about the designated nonprofit agency and the products it offers is available at <https://www.respectofflorida.org/>.

- C. **Procurement of Recycled Products or Materials.** Vendor/Consultant agrees to procure any recycled products or materials which are the subject of or are required to carry out this Contract in accordance with Section 403.7065, F.S.

10.5. NON-DISCRIMINATION

No person, on the grounds of race, creed, color, national origin, age, sex, or disability, shall be excluded from participation in, be denied the proceeds or benefits of, or be otherwise subjected to discrimination in performance of this Agreement.

10.6. NO-THIRD PARTY RIGHTS

The Parties hereto do not intend, nor shall this Agreement be construed to grant any rights, privileges or interest to any person not a party to this Agreement.

10.7. PROHIBITION OF UNAUTHORIZED ALIENS

ALIENS In accordance with Federal Executive Order 96-236, Hernando County shall consider the employment by the Vendor/Consultant of unauthorized aliens a violation of Section 274A(e) of the Immigration and Nationalization Act. Such violation shall be cause for unilateral cancellation of this Agreement if the Vendor/Consultant knowingly employs unauthorized aliens.

10.8. FORCE MAJEURE AND NOTICE OF DELAY FROM FORCE MAJEURE

Neither Party shall be liable to the other for any delay or failure to perform under this Agreement if such delay or failure is neither the fault nor the negligence of the Party or its employees or agents and the delay is due directly to acts of God, wars, acts of public enemies, strikes, fires, floods, or other similar cause wholly beyond the Party's control, or for any of the foregoing that affects subcontractors or suppliers if no alternate source of supply is available. However, in the event of delay from the foregoing causes, the Party shall take all reasonable measures to mitigate any and all resulting delay or disruption in the Party's performance obligation under this Agreement. If the delay is excusable under this paragraph, the delay will not result in any additional charge or cost under the Agreement to either Party. In the case of any delay Agreement believes is excusable under this paragraph, Vendor/Consultant shall notify Hernando County's Grant Manager in writing of the delay or potential delay and describe the cause of the delay either:

- A. within ten (10) calendar days after the cause that creates or will create the delay first arose, if Vendor/Consultant could reasonably foresee that a delay could occur as a result; or
- B. within five (5) calendar days after the date Vendor/Consultant first had reason to believe that a delay could result, if the delay is not reasonably foreseeable.

THE FOREGOING SHALL CONSTITUTE VENDOR/CONSULTANT'S SOLE REMEDY OR EXCUSE WITH RESPECT TO DELAY.

Providing notice in strict accordance with this paragraph is a condition precedent to such remedy. Hernando County, in its sole discretion, will determine if the delay is excusable under this paragraph and will notify Vendor/Consultant of its decision in writing. No claim for damages, other than for an extension of time, shall be asserted against Hernando County. Vendor/Consultant shall not be entitled

to an increase in the Agreement price or payment of any kind from Hernando County for direct, indirect, consequential, impact, or other costs, expenses or damages, including but not limited to costs of acceleration or inefficiency arising because of delay, disruption, interference, or hindrance from any cause whatsoever. If performance is suspended or delayed, in whole or in part, due to any of the causes described in this paragraph, after the causes have ceased to exist, Vendor/Consultant shall perform at no increased cost, unless Hernando County determines, in its sole discretion, that the delay will significantly impair the value of the Agreement to Hernando County or the State, in which case, Hernando County may do any or all of the following:

- A. accept allocated performance or deliveries from Vendor/Consultant, provided that Vendor/Consultant grants preferential treatment to Hernando County with respect to products or services subjected to allocation;
- B. purchase from other sources (without recourse to and by Vendor/Consultant for the related costs and expenses) to replace all or part of the products or services that are the subject of the delay, which purchases may be deducted from the Agreement quantity; or
- C. terminate the Agreement in whole or in part.

10.9. DISADVANTAGED, MINORITY, WOMEN'S, SERVICE-DISABLED AND SMALL BUSINESS ENTERPRISE POLICY AND OBLIGATION

- A. It is the policy of the Department that DBE's, as defined in 49 C.F.R. Part 26, as amended, shall have the opportunity to participate in the performance of contracts financed in whole or in part with Department funds under this Agreement. The DBE requirements of applicable federal and state laws and regulations apply to this Agreement.
- B. The Agency and its contractors agree to ensure that Minority, Women's, Service-Disabled and Small Business Enterprises have the opportunity to participate in the performance of this Agreement. In this regard, all recipients and contractors shall take all necessary and reasonable steps in accordance with applicable federal and state laws and regulations to ensure that the Minority, Women's, Service-Disabled and Small Business Enterprise's have the opportunity to compete for and perform contracts. The Agency and its contractors and subcontractors shall not discriminate based on race, color, national origin or sex in the award and performance of contracts, entered pursuant to this Agreement.
- C. The Bidder/Contractor is required to submit documentation upon request to the County to reflect the affirmative action steps taken to utilize minority owned, women owned, service-disabled veteran and small business enterprises in the work and the intended use of these companies in the work.
- D. The Bidder/Contractor is required to include in their bid documentation that the Bidder has carried out these affirmative steps for Minority, Women's, Service-Disabled Veteran and Small Business Enterprise participation as follows:
 - 1. Included qualified minority and women's businesses on solicitation lists.

2. Solicited Minority, Women's, Service-Disabled and Small Business's whenever they are potential sources.
 3. Divided total requirements, when economically feasible, into small tasks or quantities to permit maximum participation by Minority, Women's, Service-Disabled and Small businesses.
 4. Where feasible, established delivery schedules which will encourage participation by Minority, Women's, Service-Disabled and Small businesses.
- E. The following websites are provided to assist Bidder/Contractor with Affirmative steps.
1. U.S. Small Business Administration <https://www.sba.gov/search?q=dsbs>
 2. Florida Department of Transportation, Equal Opportunity Office <https://www.fdot.gov/equalopportunity/default.shtml>
 3. <https://fdotxwp02.dot.state.fl.us/EqualOpportunityOfficeBusinessDirector>
 4. Florida Certified Business Enterprise <https://vendor.myfloridamarketplace.com/>
- F. Bidder/Contractor will be responsible for participating in these affirmative steps and providing documentation to that effect. County will be responsible to verify/certify it has obtained and reviewed documentation from the apparent lowest, responsive, responsible bidder demonstrating a good faith effort to facilitate Minority, Women's, Service-Disabled and Small Business Enterprise participation in this contract.

10.10. GOOD FAITH EFFORTS

The County is committed to supplier diversity in the performance of all contracts associated with Federal and State funding projects. The County requires the Bidder/Contractor to make good faith efforts to encourage the participation of minority, woman, service-disabled veteran and small business enterprises in accordance with applicable laws.

10.11. INTEREST OF MEMBERS OF, OR DELEGATES TO, CONGRESS OR LEGISLATURE

No member or delegate to the Congress of the United States, or the State of Florida legislature, shall be admitted to any share or part of the Agreement or any benefit arising therefrom.

10.12. LITIGATION, INVESTIGATIONS, ARBITRATION, OR ADMINISTRATIVE PROCEEDINGS

The contractor certifies that it, its principals and agents, are not engaged in any civil or criminal litigation investigations, arbitration, or administrative proceedings relating to or affecting their ability to perform under this Agreement.

10.13. PROMPT PAYMENT

Monthly actual payment reporting requirements for prime contractors and consultants are based on prompt payment rules and laws. The same holds true for return of retainage after the sub-contractor has completed its work, not when the overall project is finished. Florida Law requires timely payment for both construction and non-construction services. Generally, invoices for construction contracts must be paid within twenty-five (25) days of receipt. Invoices for consultant contracts are payable per the contract terms but shall not exceed federal regulations in 49 CFR 26.29 that requires payment of all subcontractors for satisfactory performance within thirty (30) days of payment to the Prime.

10.14. PUBLIC RECORDS ACCESS REQUIREMENTS

- A. If the Contractor is acting on behalf of the Department in its performance of services under the Contract, the Contractor must allow public access to all documents, papers, letters, or other material, regardless of the physical form, characteristics, or means of transmission, made or received by the Contractor in conjunction with the Contract (Public Records), unless the Public Records are exempt from public access pursuant to section 24(a) of Article I of the Florida Constitution or section 119.07(1), F.S.
- B. The Department may unilaterally terminate the Contract if the Contractor refuses to allow public access to Public Records as required by law.

10.15. PUBLIC RECORDS REQUIREMENTS APPLICABLE TO ALL CONTRACTORS

- A. For purposes of the Contract, the Contractor is responsible for becoming familiar with Florida's Public Records law, consisting of chapter 119, F.S., section 24(a) of Article I of the Florida Constitution, or other applicable state or federal law (Public Records Law).
- B. All requests to inspect or copy Public Records relating to the Contract must be made directly to the Department. Notwithstanding any provisions to the contrary, disclosure of any records made or received by the State in conjunction with the Contract is governed by Public Records Law.
- C. If the Contractor has a reasonable, legal basis to assert that any portion of any records submitted to the Department are confidential, proprietary, trade secret, or otherwise not subject to disclosure ("Confidential" or "Trade Secret") under Public Records Law or other authority, the Contractor must simultaneously provide the Department with a separate redacted copy of the records the Contractor claims as Confidential or Trade Secret and briefly describe in writing the grounds for claiming exemption from the Public Records Law, including the specific statutory citation for such exemption. The un-redacted copy of the records must contain the Contract name and number and must be clearly labeled "Confidential" or "Trade Secret." The redacted copy of the records should only redact those portions of the records that the Contractor claims are Confidential or Trade Secret. If the Contractor fails to submit a redacted copy of records it claims are Confidential or Trade Secret, such action may constitute a waiver of any claim of confidentiality.

- D. If the Department receives a Public Records request, and if records that have been marked as "Confidential" or "Trade Secret" are responsive to such request, the Department will provide the Contractor-redacted copies to the requester. If a requester asserts a right to the portions of records claimed as Confidential or Trade Secret, the Department will notify the Contractor that such an assertion has been made. It is the Contractor's responsibility to assert that the portions of records in question are exempt from disclosure under Public Records Law or other authority. If the Department becomes subject to a demand for discovery or disclosure of the portions of records the Contractor claims as Confidential or Trade Secret in a legal proceeding, the Department will give the Contractor prompt notice of the demand, when possible, prior to releasing the portions of records the Contractor claims as Confidential or Trade Secret (unless disclosure is otherwise prohibited by applicable law). The Contractor shall be responsible for defending its determination that the redacted portions of its records are Confidential or Trade Secret. No right or remedy for damages against the Department arises from any disclosure made by the Department based on the Contractor's failure to promptly legally protect its claim of exemption and commence such protective actions within ten days of receipt of such notice from the Department.
- E. If the Contractor claims that the records are "Trade Secret" pursuant to section 624.4213, F.S., and all the requirements of section 624.4213(1), F.S., are met, the Department will respond to the Public Records Request in accordance with the provisions specified in that statute.
- F. The Contractor shall ensure that exempt or confidential and exempt Public Records are not disclosed except as permitted by the Contract or by Public Records Law.

10.16.RECORDS RETENTION

All records shall be maintained for five (5) years following the close of this Agreement. The Contractor shall cooperate with Hernando County to facilitate the duplication and transfer of such records upon Hernando County's request.

10.17.RESTRICTIONS ON LOBBYING STATE

- A. Contractors shall ensure compliance with Section 11.062, FS and Section 216.347, FS. The Contractor shall not, in connection with this or any other agreement with the State, directly or indirectly
 1. offer, confer, or agree to confer any pecuniary benefit on anyone as consideration for any State officer or employee's decision, opinion recommendation, vote, other exercise of discretion, or violation of a known legal duty, or
 2. offer, give, or agree to give to anyone any gratuity for the benefit of, or at the direction or request of, any State officer or employee. For purposes of clause (13.2), "gratuity" means any payment of more than nominal monetary value in the form of cash, travel, entertainment, gifts, meals, lodging, loans, subscriptions, advances, deposits of money, services, employment, or contracts of any kind. Upon request of Department's Inspector

General, or other authorized State official, the Contractor shall provide any type of information the Inspector General deems relevant to the Contractor's integrity or responsibility. Such information may include, but shall not be limited to, the Contractor's business or financial records, documents, or files of any type or form that refer to or relate to the Contract. The Contractor shall retain such records for the longer of

- a. three years after the expiration of the Contract or
- b. the period required by the General Records Schedules maintained by the Florida Department of State. (available at: <http://dos.myflorida.com/library-archives/records-management/general-records-schedules/>). The Contractor agrees to reimburse the State for the reasonable costs of investigation incurred by the Inspector General or other authorized State official for investigations of the Contractor's compliance with the terms of this or any other agreement between the Contractor and the State which results in the suspension or debarment of the Contractor. Such costs shall include but shall not be limited to salaries of investigators, including overtime; travel and lodging expenses; and expert witness and documentary fees. The Contractor shall not be responsible for any costs of investigations that do not result in the Contractor's suspension or debarment.

10.18. RESTRICTIONS, PROHIBITIONS, CONTROLS, AND LABOR PROVBISIONS

- A. During the performance of this Contract, Hernando County requires the following provisions to be included in each contract and subcontract entered into pursuant to this Contract.
 1. A person or affiliate who has been placed on the convicted vendor list following a conviction for a public entity crime may not submit a bid on a contract to provide any goods or services to a public entity; may not submit a bid on a contract with a public entity for the construction or repair of a public building or public work; may not submit bids on leases of real property to a public entity; may not be awarded or perform work as a contractor, supplier, subcontractor or consultant under a contract with any public entity; and may not transact business with any public entity in excess of the threshold amount provided in Section 287.017, Florida Statutes, for CATEGORY TWO for a period of 36 months from the date of being placed on the convicted vendor list.
 2. In accordance with Section 287.134, Florida Statutes, an entity or affiliate who has been placed on the Discriminatory Vendor List, kept by the Florida Department of Management Services, may not submit a bid on a contract to provide goods or services to a public entity; may not submit a bid on a contract with a public entity for the construction or repair of a public building or public work; may not submit bids on leases of real property to a public entity; may not be awarded or perform work as a contractor, supplier, subcontractor or consultant under a contract with any public entity; and may not transact business with any public entity.

3. An entity or affiliate who has had its Certificate of Qualification suspended, revoked, denied or have further been determined by the Department to be a non-responsible contractor may not submit a bid or perform work for the construction or repair of a public building or public work on a contract with the Recipient.
4. No funds received pursuant to this Agreement may be expended for lobbying the Florida Legislature, judicial branch, or any state agency, in accordance with Section 216.347, Florida Statutes.
 - a. The Recipient shall comply and require its contractors and subcontractors to comply with all terms and conditions of this Agreement and all federal, state, and local laws and regulations applicable to this Project

10.19. TITLE VI-CIVIL RIGHTS ACT OF 1964

Execution of this Agreement constitutes a certification that the Agency will comply with all the requirements imposed by Title VI of the Civil Rights Act of 1964 (42 U.S.C. 2000d, et seq.), the Regulations of the Federal Department of Transportation issued thereunder, and the assurance by the Agency pursuant thereto.

10.20. TITLE VIII-CIVIL RIGHTS ACT OF 1968

Execution of this Agreement constitutes a certification that the Agency will comply with all the requirements imposed by Title VIII of the Civil Rights Act of 1968 (42 U.S.C. 3601, et seq.), which among other things, prohibits discrimination in employment on the basis of race, color, national origin, creed, sex, and age.

10.21. MISCELLANEOUS PROVISIONS

- A. The Contractor agrees to comply with Section 20.055(5), Florida Statutes, and to incorporate in all subcontracts the obligation to comply with Section 20.055(5), Florida Statutes.
- B. This Contract shall be governed by and construed in accordance with the laws of the State of Florida. In the event of a conflict between any portion of the contract and Florida law, the laws of Florida shall prevail.

11. SCOPE AND SPECIFICATIONS

11.1. SCOPE OF WORK

The Vendor/Contractor will supply all materials, labor, and equipment in order to accomplish the Dr. Dennis Wilfong Center for Success/Infrastructure - Rebid, as described in the specifications and construction plans showing the proposed improvements in Hernando County, Florida.

11.2. PROJECT DESCRIPTION:

- A. This project consists of Infrastructure construction including but not limited to: drainage improvements and retention ponds, access roadway from Spring Hill Drive to Helicopter Drive, gopher tortoise relocation and as described in the details, plans and specifications..
- B. It will be the Vendor/Contractor's responsibility to provide an acceptable MOT plan at the Pre-Construction meeting along with a chart showing the project schedule.
- C. The Vendor/Contractor shall comply with all applicable OSHA workplace safety requirements and shall accomplish the work in a manner providing for the safety of their equipment and workers and for the safety of the general public.

11.3. LOCATION OF THE WORK:

The work to be performed in this contract will be performed on Spring Hill Drive and Helicopter Drive, in Hernando County, Florida.

11.4. GENERAL REQUIREMENTS AND TECHNICAL SPECIFICATIONS

Refer to the Attachments section.

- A. Clarifications to the plans in the Attachments section:
 - 1. Vendor/Contractor will be required to provide an electrical design for the pump station that includes sizing of the generator.
 - 2. Removal and disposal of excess soil from excavating the site is the Vendor/Contractor's responsibility.

11.5. SURVEY CONTROL

Vendor/Contractor will furnish all surveys and construction stakeouts unless otherwise specified. The Vendor/Contractor will provide horizontal control and bench marks or elevations for vertical control. The Vendor/Contractor shall furnish, free of charge, all stakes, all templates, and other materials necessary for marking and maintaining points and lines given. The Vendor/Contractor shall be held responsible for the preservation of all stakes and markers, and if the stakes or markers are destroyed or disturbed, the cost of replacing them shall be charged against the Vendor/Contractor, and shall be deducted from the payment for the work. The Vendor/Contractor shall be responsible for any mistakes that may be caused by their unnecessary loss or disturbance.

11.6. TRAFFIC CONTROL

- A. The Vendor/Contractor shall be responsible for installing, operating, and maintaining all traffic control associated with the project, including detours, advance warnings, channelization, or other features, both at the immediate work site and at outlying points as detailed on the construction plans or as referenced by the FDOT indexes.
- B. Vendor/Contractor shall prepare a detailed traffic control plan designed to accomplish the level of performance outlined in the scope of work, and incorporating the methods and criteria contained in the Manual on Uniform Traffic Control Devices published by the U.S. Department of Transportation and adopted as amended by the FDOT. This plan must be approved in writing by the Engineer.
- C. The Engineer may inspect and monitor the traffic control scheme and devices of the Vendor/Contractor and shall, through the Project Manager or County's Designated Inspector assigned to the project, make known his requirements for any alterations and adjustments to the control plan or devices. The Vendor/Contractor shall take direction only as appropriately expressed by the Inspector or Engineer.

11.7. ON SITE BURNING

- A. On site burning may be permitted with the following requirements:
 - 1. A Certified Burner (CB), or a contract with a Certified Burner.
 - 2. The Vendor/Contractor shall apply for and obtain a Burn Authorization from the Florida Forest Service - Withlacoochee Forestry Center's main office.
 - 3. Due to the "Sensitive Area" of the site location, a Forest Ranger site inspection will be required to determine the equipment necessary and/or restrictions needed.
 - a. An air curtain incinerator will be required.

Vendor/Contractors are encouraged to contact the Forest Area Supervisor (FAS), Jason Packard or Brian Prill, that supervise the Forest Rangers for Hernando County by contacting the Dispatch Center at (352) 797-4100.

12. GENERAL REQUIREMENTS AND TECHNICAL SPECIFICATIONS

12.1. [See attachments](#)

13. BID/PROPOSAL PRICING

The Total Bid Price below shall be all inclusive of all requirements of the plans. Any discrepancies identified during the bid process should be addressed during the question period.

The unit prices below shall be used to determine adjustment to the contract sum when changes in the work involving said items are deemed necessary.

Unit Prices shall apply until the date of contract completion established at the time of Notice to Proceed.

All unit prices shall include the pro-rata share of all costs of materials, equipment and disposal required to complete the work item. Overhead, profit and bond will be calculated per Change Order Proposal.

GENERAL CONDITIONS

Line Item	Description	Quantity	Unit of Measure	Unit Cost	Total
1	Mobilization	1	LS		
2	Insurance, Permits, and Performance & Payment Bond	1	LS		
3	Maintenance of Traffic	1	LS		
4	Survey Layout/As-built	1	LS		
5	Pre/Post Video	1	LS		
6	Erosion Sediment Control (includes NPDES Permit/Inspection Report/NOT	1	LS		
TOTAL					

CLEARING, GRUBBING AND EARTHWORK

Line Item	Description	Quantity	Unit of Measure	Unit Cost	Total
7	Clearing/Grubbing (includes DRA & Floodplain Comp)	20	AC		
8	Embankment Excavation, Filling and Grading	1	LS		
9	Temporary Construction Access	1	LS		

Line Item	Description	Quantity	Unit of Measure	Unit Cost	Total
10	Silt Fence Installation and Removal	5,800	LF		
TOTAL					

STORM DRAINAGE

Line Item	Description	Quantity	Unit of Measure	Unit Cost	Total
11	15" RCP	68	LF		
12	18" RCP	508	LF		
13	24" RCP	92	LF		
14	29" x 45" ERCP	104	LF		
15	30" RCP	266	LF		
16	42" RCP	266	LF		
17	48" RCP	334	LF		
18	FDOT Gutter Type V Inlet	6	EA		
19	FDOT Type C Inlet	1	EA		
20	FDOT Type F Inlet	2	EA		
21	FDOT Type G Inlet	1	EA		
22	FDOT Type 7 Inlet	1	EA		
23	24" MES	3	EA		
24	29" x 45" MES	2	EA		
25	48" MES	1	EA		
26	Rip Rap	650	SF		

Line Item	Description	Quantity	Unit of Measure	Unit Cost	Total
27	Concrete Weir with Skimmer	1	EA		
28	Sod DRA Side Slopes	13,800	SY		
29	Seed and Mulch DRA	56,000	SY		
TOTAL					

SANITARY SEWER

Line Item	Description	Quantity	Unit of Measure	Unit Cost	Total
30	8" PVC SDR 26 (0'-6')	350	LF		
31	8" PVC SDR 26 (6'-8')	350	LF		
32	8" PVC SDR 26 (8'-10')	222	LF		
33	Manholes (0'-6')	2	EA		
34	Manholes (6'-8')	1	EA		
35	Manholes (8'-10')	1	EA		
36	LS Receiving Manhole (8'-10') Coated	1	EA		
37	Pump Station Complete	1	LS		
38	Gravity Sewer Testing	922	LF		
39	4" PVC C-900 Force Main	1,840	LF		
40	4" MJ 45 Ftg with Restraints	10	EA		
41	4" x 6" Tapping Sleeve and Valve	1	EA		
42	Force Main Pressure Testing	1,840	LF		
43	Stabilized Roadway	930	SY		

Line Item	Description	Quantity	Unit of Measure	Unit Cost	Total
TOTAL					

WATER DISTRIBUTION

Line Item	Description	Quantity	Unit of Measure	Unit Cost	Total
44	8" PVC C-900 Water Main	100	LF		
45	12" PVC C-900 Water Main	1,150	LF		
46	12" MJ 45 Ftg with Restraints	4	EA		
47	12" x 4" Tee Ftg with Restraints	3	EA		
48	12" x 8" Tee Ftg with Restraints	3	EA		
49	12" x 8" Cross Ftg with Restraints	1	EA		
50	4" Gate Valve with Restraints	3	EA		
51	8" Gate Valve with Restraints	5	EA		
52	12" Gate Valve with Restraints	2	EA		
53	4" End Cap with Restraints	3	EA		
54	8" End Cap with Restraints	3	EA		
55	Temporary Water Service Connection (HCUD Detail #42)	1	EA		
56	Cut and Connect to Existing Water Main	4	EA		
57	Water Testing/Chlorination	1,250	LF		
TOTAL					

ROAD CONSTRUCTION

Line Item	Description	Quantity	Unit of Measure	Unit Cost	Total
58	12" Type B Stabilized Subgrade	2,920	SY		
59	8" Limerock Base	2,920	SY		
60	1-5" Type SP-12.5 Asphalt (Traffic Level C)	2,920	SY		
61	1" Type SP-9.5 Asphalt (Traffic Level C)	2,920	SY		
62	Drop Curb	1,100	LF		
63	Valley Gutter	130	LF		
64	Sod R/W	7,600	SY		
65	5' Concrete Sidewalk (3,000 psi/4" thick)	19,332	SF		
66	Curb Ramp with Tactile Surface	4	EA		
67	10' x 10' Concrete Pad (3,000 psi/4" thick)	2	EA		
68	Seed and Mulch R/W, Easements	8,900	SY		
69	Striping/Signage	1	LS		
TOTAL					

GOPHER TORTOISE RELOCATION

Line Item	Description	Quantity	Unit of Measure	Unit Cost	Total
70	Gopher Tortoise Survey & Permitting	1	LS		
71	Gopher Tortoise Burrow Excavation	18	EA		
72	Gopher Tortoise Relocation	10	EA		
TOTAL					

14. VENDOR QUESTIONNAIRE

14.1. THE UNDERSIGNED, BEING DULY AUTHORIZED TO SUBMIT THIS BID ON BEHALF OF THE BIDDER, AGREES THAT THIS OFFER IF ACCEPTED WITHIN ONE HUNDRED TWENTY (120) DAYS FROM THE BID OPENING DATE, TO FURNISH TO HERNANDO COUNTY ANY AND ALL ITEMS FOR WHICH PRICES ARE OFFERED IN THIS BID SOLICITATION AT THE PRICE(S) SO OFFERED, DELIVERED AT DESIGNATED POINT(S), WITHIN THE TIME PERIOD SPECIFIED, AND AT THE TERMS AND CONDITIONS SO STIPULATED IN THE SOLICITATION FOR BIDS.*

Please confirm

*Response required

14.2. Authorized person *

Are you fully authorized to bind this company, or corporation.

Yes

No

*Response required

14.3. Authorized Person's information *

Please provide your

Name

Title

Business Address

*Response required

14.4. [Bi](#)
[dder accepts all of the terms and conditions of the Instructions to Bidders,](#)
[including without limitation those dealing with the disposition of bid security. *](#)

Please confirm

*Response required

14.5. [Up](#)
[load Florida Permit](#)

Bidders who are non-resident corporations shall furnish to the Owner a duly certified copy of their permit to transact business in the State of Florida along with the bid. Failure to submit this evidence or qualification to do business in the State of Florida may be basis for rejection of the bid.

14.6. [Bi](#)
[dder Acknowledgement*](#)

Agree at the time of submitting its bid that no further examinations, investigations, explorations, tests, studies, or data are necessary for the determination of its bid for performance of the work at the price(s) bid and within the times and in accordance with the other terms and conditions of the bid documents.

Please confirm

*Response required

14.7. [BI](#)
[D FORM CONFIRMATION *](#)

The Board of County Commissioners

Hernando County, Florida

The undersigned, hereinafter called "Bidder", having visited the site of the proposed project and familiarized himself with the local conditions, nature and extent of the work, and having examined carefully the agreement form, General Conditions, Special Conditions, Supplementary Conditions for Federal/State Requirements, plans and specifications and other contract documents, with the bond requirements herein, proposed to furnish all labor, materials, equipment and other necessary items, facilities and services for the proper execution and completion of the subject project in full accordance with the drawings and specifications prepared in accordance with your Advertisement of Bids, instruction to bidders, agreement and all other documents related thereto on file in the office of the Hernando County Procurement Department and if awarded the Contract, to complete said work within the time limits specified for their bid price.

Please confirm

*Response required

14.8. [Co
mpany Information *](#)

Please Provide the following:

Company Name

Contact Person, and Title

Mailing Address

Telephone number

Email Address

Fax number

*Response required

14.9. [Bi
d Bond Confirmation *](#)

If the foregoing proposal shall be accepted by Hernando County, Florida, and the undersigned shall fail to execute a satisfactory contract as stated in the advertisement herein attached, then the County may, at its option, determine that the undersigned has abandoned the Contract, and thereupon this proposal shall be null and void, and the certified check or bond accompanying this proposal, shall be forfeited to and become the property of Hernando County, Florida, and the full amount of said check shall be retained by the County, or if the proposal bond be given, the full amount of such bond shall be paid to the County as stipulated for liquidated damages; otherwise, the bond or certified check accompanying this proposal, or the amount of said check, shall be returned to the undersigned as specified herein.

If corporation, give the names and addresses of the president and secretary. If firm or partnership, the names and addresses of the members or partners. The Bidder shall list not only his name, but also the name of any person with whom Bidder has any type of agreement whereby such person's improvements, enrichment, employment of possible benefit, whether subcontractor, materialman, agent, supplier, or employer, is contingent upon the award of the Contract to the Bidder).

Please confirm

*Response required

14.10..... [Bi](#)
[dder confirmation \(proposal one\) *](#)

Every Bidder must take notice of the fact that even though his proposal be accepted and the documents signed by the Bidder to whom an award is made and by those officials authorized to do so on behalf of Hernando County, Florida, that no such award or signing shall be considered a binding contract without a certificate from the Finance Director that funds are available to cover the cost of the work to be done, or without the approval of the County Attorney as to the form and legality of the Contract and all the pertinent documents relating thereto having been approved by said County Attorney; and such Bidder is hereby charged with this notice.

The signer of the proposal, as Bidder, also declares that the only person, persons, company or parties interested in this proposal, are named in the proposal, that he has carefully examined the Advertisement of Bid, Solicitation Instructions, Contract Specifications, Plans, Supplementary Conditions for Federal/State Requirements, General Conditions, Special Conditions, Special Provisions and contract bond, that he or his representative has made such investigation as is necessary to determine the character and extent of the work and he proposes and agrees that if the proposal be accepted, he will contract with Hernando County, Florida in the form of contract hereto annexed, to provide the necessary labor, materials, machinery, equipment, tools or apparatus, do all the work required to complete the Contract within the time mentioned in the Contract Documents according to the requirements of Hernando County, Florida, as herein and hereinafter set forth, and furnish the required surety bonds for the following prices to wit:

Please confirm

*Response required

14.11..... [Ful](#)
[l names and addresses \(proposal two\) *](#)

Please provide the full names and residences of all persons and parties interested in the foregoing bid are as follows:

If corporation, give the names and addresses of the president and secretary. If firm or partnership, the names and addresses of the members or partners. The Bidder shall list not only his name, but also the name of any person with whom Bidder has any type of agreement whereby such person's improvements, enrichment, employment of possible benefit, whether subcontractor, materialman, agent, supplier, or employer, is contingent upon the award of the Contract to the Bidder).

PLEASE TYPE NAMES AND ADDRESSES AS REQUESTED.

*Response required

14.12..... [BI](#)
[D GUARANTEE](#)

Bidder has enclosed a Certified check, Cashier's Check or Bid Bond in the amount of not less than the five percent (5%) of the Total Base Bid Amount payable to the Hernando County Board of County Commissioners as a guarantee for the purpose set out in the Instructions to Bidders.

Please confirm

14.13..... [Ple](#)
[ase provide construction experience*](#)

Overview of construction experience, including a list of projects successfully completed and indicating Owner, location, Contract value and completion date.

*Response required

14.14..... [Ex](#)
[perience detail*](#)

Documentation of two (2) projects, similar in scope and complexity to this project, which have been successfully completed by the Bidder within the past seven (7) years.

*Response required

14.15..... [Dr](#)
[ug Free Workplace Certification *](#)

I have read and attest to, in accordance with Florida Statute 287.087 (current version), hereby certify that,

Publishes a written statement notifying that the unlawful manufacture, distribution, dispensing, possession or use of a controlled substance is prohibited in the workplace named above, and specifying actions that will be taken against violations of such prohibition.

Informs employees about the dangers of drug abuse in the workplace, the firm’s policy of maintaining a drug free working environment, and available drug counseling, rehabilitation, and employee assistance programs, and the penalties that may be imposed upon employees for drug use violations.

Gives each employee engaged in providing commodities or contractual services that are under proposal a copy of the statement specified above.

Notifies the employees that as a condition of working on the commodities or contractual services that are under proposal, the employee will abide by the terms of the statement and will notify the employer of any conviction of, pleas of guilty or nolo contendere to, any violation of Chapter 893, or of any controlled substance law of the State of Florida or the United States, for a violation occurring in the workplace, no later than five (5) days after such conviction, and requires employees to sign copies of such written statement to acknowledge their receipt.

Imposes a sanction on, or requires the satisfactory participation in, a drug abuse assistance or rehabilitation program, if such is available in the employee’s community, by any employee who is so convicted.

Makes a good faith effort to continue to maintain a drug free workplace through the implementation of the Drug Free Workplace Program.

“As a person authorized to sign this statement, I certify that the above named business, firm or corporation complies fully with the requirements set forth herein”.

Please Confirm that you have read and attest to Download Drug Free Workplace Certificate

Please confirm

*Response required

14.16..... [Affidavit of Non Collusion and of Non-Interest of Hernando County Employees*](#)

Affidavit of Non Collusion and of Non-Interest of Hernando County Employees

Certification that Vendor/Contractor affirms that the bid/proposal presented to the Owner is made freely, and without any secret agreement to commit a fraudulent, deceitful, unlawful or wrongful act of collusion.

I have read and attest that I am the Vendor/Contractor in the above bid/proposal, that the only person or persons interested in said proposal are named therein; that no officer, employee or agent of the Hernando County Board of County Commissioners (BOCC) or of any other Vendor/Contractor is interested in said bid/proposal; and that affiant makes the above bid/proposal with no past or present collusion with any other person, firm or corporation.

Please confirm that you have read and attest to Affidavit of Non Collusion and of Non-Interest of Hernando County Employees

Please confirm

*Response required

14.17..... [Sworn Statement](#)

14.17.1. *Sworn Statement 287.133 (3) (a)**

I have read and attest that I understand that a "public entity crime" as defined in Paragraph 287.133 (1)(g), Florida Statutes (current version), means a violation of any public entity or with an agency or political subdivision of any other state or of the United States, including, but not limited to, any proposal or contract for goods or services to be provided to any public entity or an agency or political subdivision of any other state or of the United States and involving antitrust, fraud, theft, bribery, collusion, racketeering, conspiracy, or material misrepresentation.

I have read and attest that I understand that "convicted" or "conviction" as defined in Paragraph 287.133 (1)(b), Florida Statutes (current version), means a finding of guilt or a conviction of a public entity crime, with or without an adjudication of guilt, in any Federal or State trial court of record relating to charges brought by indictment or information after July 1, 1989, as a result of a jury verdict, non-jury trial, or entry of a plea of guilty or nolo contendere.

I have read and attest that I understand that an "affiliate" as defined in Paragraph 287.133 (1)(a), Florida Statutes (current version), means:

- A. A predecessor or successor of a person convicted of a public entity crime; or
- B. An entity under the control of any natural person who is active in the management of the entity and who has been convicted of a public entity crime. The term "affiliate" includes those officers, directors, executives, partners, shareholders, employees, members, and agents who are active in the management of an affiliate. The ownership by one (1) person of shares constituting a controlling interest in another person, or a pooling of equipment or income among persons when not for fair market value under an arm's length agreement, shall be a prima facie case that one (1) person controls another person. A person who knowingly enters into a joint venture with a person who has been convicted of a public entity crime in Florida during the preceding thirty-six (36) months shall be considered an affiliate.

I have read and attest that I understand that a "person" as defined in Paragraph 287.133(1)(e), Florida Statutes (current version), means any natural person or entity organized under the laws of any state or of the United States with the legal power to enter into a binding contract and which proposals or applies to proposal on contracts for the provisions of goods or services let by a public entity, or which otherwise transacts or applies to transact business with a public entity. The term "person" includes those officers, directors, executives, partners, shareholders, employees, members, and agents who are active in management of an entity.

I have read and attest that based on information and belief, the statement which I have confirmed below is true in relation to the entity submitting this sworn statement:

_____ [attach a copy of the final order].

I UNDERSTAND THAT THE SUBMISSION OF THIS FORM TO THE CONTRACTING OFFICER FOR THE PUBLIC ENTITY IDENTIFIED IN PARAGRAPH ONE (1) ABOVE IS FOR THAT PUBLIC ENTITY ONLY AND,

THAT THIS FORM IS VALID THROUGH DECEMBER 31, OF THE CALENDAR YEAR IN WHICH IT IS FILED. I ALSO UNDERSTAND THAT I AM REQUIRED TO INFORM THE PUBLIC ENTITY PRIOR TO ENTERING INTO A CONTRACT.

Neither the entity submitting this sworn statement, nor any of its officers, directors, executives, partners, shareholders, employees, members, or agents who are active in the management of the entity, nor any affiliate of the entity has been charged with and convicted of a public entity crime subsequent to July 1, 1989.

The entity submitting this sworn statement, or one (1) or more of its officers, directors, executives, partners, shareholders, employees, members, or agents who are active in the management of the entity, or an affiliate of the entity has been charged with and convicted of a public entity crime subsequent to July 1, 1989.

The entity submitting this sworn statement, or one (1) or more of its officers, directors, executives, partners, shareholders, employees, members, or agents who are active in the management of the entity, or an affiliate of the entity has been charged with and convicted of a public entity crime subsequent to July 1, 1989. However, there has been a subsequent proceeding before a Hearing Officer of the State of Florida, Division of Administrative Hearings and the Final Order entered by the Hearing Officer determined that it was not in the public interest to place the entity submitting this sworn statement on the convicted Vendor/Contractor list

*Response required

14.17.2. If you choose option 3, please attach a copy of the final order

If you choose option 3, please attach a copy of the final order

The entity submitting this sworn statement, or one (1) or more of its officers, directors, executives, partners, shareholders, employees, members, or agents who are active in the management of the entity, or an affiliate of the entity has been charged with and convicted of a public entity crime subsequent to July 1, 1989. However, there has been a subsequent proceeding before a Hearing Officer of the State of Florida, Division of Administrative Hearings and the Final Order entered by the Hearing Officer determined that it was not in the public interest to place the entity submitting this sworn statement on the convicted Vendor/Contractor list

Please attach a copy of the final order

14.18..... [Authorized Signatures/Negotiators](#)

*14.18.1. Authorized Signatures/Negotiators **

Please provide the information to support the statement below:

The Vendor/Contractor represents that the following persons are authorized to sign and/or negotiate contracts and related documents to which the Vendor/Contractor will be duly bound:

Name(s)

Title(s)

Phone no (s)

*Response required

14.18.2. Type of Organization *

Please select your organization type:

Sole Proprietorship

Partnership

Joint Venture

Corporation

*Response required

14.18.3. Company ID*

Please Provide Your:

State of Incorporation and

Federal I.D. NO.

*Response required

14.18.4. W9 Form *

Please upload your company's W9 information

*Response required

14.18.5. ACH electronic payment*

An ACH electronic payment method is offered as an alternative to a payment by physical check.
Please select one of the options.

Yes, ACH electronic payment method is acceptable.

No, ACH electronic payment method is not acceptable.

*Response required

14.19..... E-
VERIFY CERTIFICATION

14.19.1. *E-Verify Certification **

Vendor/Contractor acknowledges and agrees to the following:

Vendor/Contractor shall utilize the U.S. Department of Homeland Security’s E-Verify system, in accordance with the terms governing use of the system, to confirm the employment eligibility of:

All persons employed by the Vendor/Contractor during the term of the Contract to perform employment duties within Florida; and

All persons, including subcontractors, assigned by the Vendor/Contractor to perform work pursuant to the Contract with the department.

Please confirm

*Response required

14.20..... CO
STRUCTION CONTRACTOR QUALIFICATION SUBMITTAL REQUIREMENTS

14.20.1. *References **

Bidder must provide a minimum of **three (3)** references in format shown below. References must be individuals that can be readily contacted and have first-hand knowledge of the Bidder’s performance on the specific project performed by the Bidder. Each reference project must meet the following criteria:

Project at Substantial Completion or completed within the last seven (7) years.

Similar in size, dollar value and scope as this project.

Please provide information for 3 required References:

Business/Owner Name

Reference Contact Person

Reference Address

Reference Phone No.

Reference Email Address

Project Name

Project Location

Contract Project Manager

Site Superintendent

Contract Amount

Date Project Commenced

Date of Substantial Completion

Date of Final Completion

Description of Work Performed

Note: Experience shall be related to successfully completed projects within the last seven (7) years (i.e. the project must have been Substantially Complete within seven (7) years of the due date of this ITB. Only projects that are complete or substantially complete as of the bid due date will be considered).

By submitting this information, I certify that the qualifications questionnaire information is true and correct to the best of my knowledge.

*Response required

*14.20.2. Key Subcontractors**

Each Bidder must submit with its response a list of subcontractors who will perform the work in each of the following categories (key subcontractors). List the name of the proposed subcontractor, or "Bidder" if the Bidder will perform the work, after each work category:

Example:

- (1) Clearing, grubbing and earthwork construction
- (2) Storm drainage construction
- (3) Sanitary sewer and water distribution construction
- (4) Roadway construction
- (5) Gopher Tortoise survey, permitting and relocation
- (6) Pre/Post video
- (7) Sodding and seeding

If no subcontractors will be employed please state "NONE"

*Response required

14.20.3. Vendor/Contractor's License*

The Bidder must be a registered to do business in the State of Florida. **All Bidder's and/or subcontractors performing work requiring a specialty license must be licensed in the State of Florida.** This includes but is not limited to electrical and mechanical trades, as well as any other earthwork Contractor on the Bidder's team. Provide license information (as required in Paragraph 27) below for Bidder and all subcontractors identified herein.

Classification

Issuing Government License

Issue Date:

License Number:

*Response required

14.20.4. ORGANIZATION CHART:*

Bidder must provide an organization chart showing Bidder's team identifying specific responsibilities of Bidder and subcontractors.

*Response required

14.20.5. PROJECT MANAGER AND SUPERINTENDENT QUALIFICATIONS:*

Bidder must provide resumes of Project Manager and Superintendent listing qualifications, experience, education and training. The Project Manager and Superintendent must have adequate experience, generally considered as a working Project Manager/Superintendent on a minimum of two (2) projects, similar in size and scope to the Dr. Dennis Wilfong Center for Success/Infrastructure - Rebid, within the past seven (7) years.

*Response required

14.20.6. BIDDER/KEY SUBCONTRACTOR SPECIFIC QUALIFICATIONS:*

Bidder must demonstrate Bidder's/Key subcontractor's experience and expertise in the tasks provided below and at the minimum identified criteria. Specific projects, locations and Contractor who performed work must be provided.

- A. Document prior experience in construction of earthwork projects involving site clearing and excavating.
- B. Document prior experience in construction of sanitary sewer and water distribution.
- C. Document prior experience in construction of storm drainage retention areas.
- D. Document prior experience in road construction.

*Response required

14.21..... [VE](#)
[NDOR/CONTRACTOR'S LICENSE](#)

14.21.1. *VENDOR/CONTRACTOR'S LICENSE**

Please upload all contractors and subcontractors license(s) required for this project.

*Response required

14.22..... [Ad](#)
[ditional Required Forms](#)

14.22.1. *Trench Safety Act Compliance **

Please download the below documents, complete, and upload.

- [Trench Safetey Act Complian...](#)

*Response required

14.22.2. *Corporate Affidavit **

Please download the below documents, complete, and upload.

- [Corporate Affidavit.pdf](#)

*Response required

14.22.3. *Bid Bond Form **

Please download the below documents, complete, and upload.

- [BID BOND.pdf](#)

*Response required

14.22.4. *VENDOR CERTIFICATION REGARDING SCRUTINIZED COMPANIES**

Section 287.135 (Current Edition), Florida Statutes, prohibits agencies from contracting with companies for goods or services of \$1,000,000.00 or more, that are on either the Scrutinized Companies with Activities in Sudan List, the Scrutinized Companies with Activities in the Iran Petroleum Energy Sector Lists which are created pursuant to s. 215.473 F.S. (Current Edition), or the Scrutinized Companies that Boycott Israel List, created pursuant to s. 215.4725 F.S. (Current Edition), or companies that are engaged in a boycott of Israel or companies engaged in business operations in Cuba or Syria.

As the person authorized to bind on behalf of respondent, I hereby certify that the company identified above in the section entitled "Respondent Vendor Name" is not listed on either the Scrutinized Companies with Activities in Sudan List or the Scrutinized Companies with Activities in the Iran Petroleum Energy Sector List, or the Scrutinized Companies that Boycott Israel List. I further certify that the company is not engaged in a boycott of Israel. I understand that pursuant to section 287.135 (Current Edition), Florida Statutes, the submission of a false certification may subject

company to civil penalties, attorney's fees, and/or costs and does not have business operations in Cuba or Syria.

I have read and attest that I confirm the above is acknowledged.

Please confirm

*Response required

14.23..... [HE](#)
[RNANDO COUNTY EMPLOYMENT DISCLOSURE CERTIFICATION STATEMENT](#)

14.23.1. *Is any officer, partner, director, proprietor, associate or member of the business entity a former employee of Hernando County within the last two (2) years? **

Yes

No

*Response required

14.23.2. *Is any officer, partner, director, proprietor, associate or member of the business entity a relative or member of the household of a current Hernando County employee that had or will have any involvement with this procurement or contract authorization?**

Yes

No

*Response required

14.23.3. *Relatives and Former Hernando County Employees - Roles and Signatures*

If you answered yes to the either of the two prior questions regarding relatives or Hernando employees, please download the below documents, complete, and upload.

- [HC Employment Disclosure Ce...](#)

14.24..... [Ve](#)
[ndor Survey](#)

14.24.1. *Vendor Survey **

Please provide information on where you received the knowledge of the bid/request for Proposals (mark all that apply):

Select all that apply

County's eProcurement Portal (Open Gov Procurement)

Newspaper

- Procurement Department Advertisement Board
- Other (Please list in the following question)

*Response required

14.24.2. *Vendor Survey - Other*

If you choose Other please list how you received the knowledge of the bid/request for Proposals.

14.24.3. *Sample Construction Agreement **

Sample Construction Agreement for your review, including attachments that will be required after award.

- [Sample Construction Agreeme...](#)
- [Documents required after Aw...](#)

*Response required

14.24.4. *Federal/StateForms**

Please download the below documents, complete, and upload.

- [Florida Conflict of Interes...](#)
- [Felony tax certification pl...](#)
- [DBE-SUB Statement Form.pdf](#)
- [GOOD FAITH EFFORTS-with OSD...](#)
- [State Certification for Dis...](#)
- [Exp 2-18-2025 Standard Form...](#)
- [Suspension Debarment Certif...](#)

*Response required

14.24.5. *Solicitation-Offer-Award**

Please download the below document, complete Offer section, and upload.

- [Solicitation - Offer - Awar...](#)

*Response required



PROPOSAL DOCUMENT REPORT

ITB No. 23-CG0215/JG

Dr. Dennis Wilfong Center for Success/Infrastructure - Rebid

RESPONSE DEADLINE: April 10, 2023 at 10:00 am

Report Generated: Monday, April 10, 2023

Goodwin Brothers Construction, Inc Proposal

CONTACT INFORMATION

Company:

Goodwin Brothers Construction, Inc

Email:

estimator@goodwinbrosinc.com

Contact:

Tom Charlow

Address:

14341 Ponce De Leon Blvd
Brooksville, FL 34601

Phone:

N/A

Website:

N/A

Submission Date:

Apr 10, 2023 9:03 AM

ADDENDA CONFIRMATION

Addendum #1

Confirmed Apr 4, 2023 10:18 AM by Tom Charlow

Addendum #2

Confirmed Apr 4, 2023 10:18 AM by Tom Charlow

Addendum #3

Confirmed Apr 4, 2023 10:18 AM by Tom Charlow

QUESTIONNAIRE

1. THE UNDERSIGNED, BEING DULY AUTHORIZED TO SUBMIT THIS BID ON BEHALF OF THE BIDDER, AGREES THAT THIS OFFER IF ACCEPTED WITHIN ONE HUNDRED TWENTY (120) DAYS FROM THE BID OPENING DATE, TO FURNISH TO HERNANDO COUNTY ANY AND ALL ITEMS FOR WHICH PRICES ARE OFFERED IN THIS BID SOLICITATION AT THE PRICE(S) SO OFFERED, DELIVERED AT DESIGNATED POINT(S), WITHIN THE TIME PERIOD SPECIFIED, AND AT THE TERMS AND CONDITIONS SO STIPULATED IN THE SOLICITATION FOR BIDS.*

Pass

Confirmed

2. Authorized person *

Pass

Are you fully authorized to bind this company, or corporation.

Yes

3. Authorized Person's information *

Pass

Please provide your

Name

Title

Business Address

Daniel Goodwin, President, 14341 Ponce De Leon Blvd Brooksville, FL 34601

4. Bidder accepts all of the terms and conditions of the Instructions to Bidders, including without limitation those dealing with the disposition of bid security. *

Pass

Confirmed

5. Upload Florida Permit

Pass

Bidders who are non-resident corporations shall furnish to the Owner a duly certified copy of their permit to transact business in the State of Florida along with the bid. Failure to submit this evidence or qualification to do business in the State of Florida may be basis for rejection of the bid.

Chucks_Stokes_Electric_State_Lic_EC0002202_Exp_8-2024.pdfCBS_Underground_State_Lic_CUC1225138_Exp_8-2024.pdfChuck's_Fire_License_Exp._06-30-2024.pdfGoodwin_Brothers_Lic's.pdf

6. Bidder Acknowledgement*

Pass

Agree at the time of submitting its bid that no further examinations, investigations, explorations, tests, studies, or data are necessary for the determination of its bid for performance of the work at the price(s) bid and within the times and in accordance with the other terms and conditions of the bid documents.

Confirmed

7. BID FORM CONFIRMATION *

Pass

The Board of County Commissioners

Hernando County, Florida

The undersigned, hereinafter called "Bidder", having visited the site of the proposed project and familiarized himself with the local conditions, nature and extent of the work, and having examined carefully the agreement form, General Conditions, Special Conditions, Supplementary Conditions for Federal/State Requirements, plans and specifications and other contract documents, with the bond requirements herein, proposed to furnish all labor, materials, equipment and other necessary items, facilities and services for the proper execution and completion of the subject project in full accordance with the drawings and specifications prepared in accordance with your Advertisement of Bids, instruction to bidders, agreement and all other documents related thereto on file in the office of the Hernando County Procurement Department and if awarded the Contract, to complete said work within the time limits specified for their bid price.

Confirmed

8. Company Information *

Pass

Please Provide the following:

Company Name

Contact Person, and Title

Mailing Address

Telephone number

Email Address

Fax number

Goodwin Brothers Construction, Tom Charlow Estimator, 14131 Ponce De Leon Blvd Brooksville, FL 34601, 352-796-0149, estimator@goodwinbrosinc.com, 352-544-1084

9. Bid Bond Confirmation *

Pass

If the foregoing proposal shall be accepted by Hernando County, Florida, and the undersigned shall fail to execute a satisfactory contract as stated in the advertisement herein attached, then the County may, at its option, determine that the undersigned has abandoned the Contract, and thereupon this proposal shall be null and void, and the certified check or bond accompanying this proposal, shall be forfeited to and become the property of Hernando County, Florida, and the full amount of said check shall be retained by the County, or if the proposal bond be given, the full amount of such bond shall be paid to the County as stipulated for liquidated damages; otherwise, the bond or certified check accompanying this proposal, or the amount of said check, shall be returned to the undersigned as specified herein.

If corporation, give the names and addresses of the president and secretary. If firm or partnership, the names and addresses of the members or partners. The Bidder shall list not only his name, but also the name of any person with whom Bidder has any type of agreement whereby such person's improvements, enrichment, employment of possible benefit, whether subcontractor, materialman, agent, supplier, or employer, is contingent upon the award of the Contract to the Bidder).

Confirmed

10. Bidder confirmation (proposal one) *

Pass

Every Bidder must take notice of the fact that even though his proposal be accepted and the documents signed by the Bidder to whom an award is made and by those officials authorized to do so on behalf of Hernando County, Florida, that no such award or signing shall be considered a binding contract without a certificate from the Finance Director that funds are available to cover the cost of the work to be done, or without the approval of the County Attorney as to the form and legality of the Contract and all the pertinent documents relating thereto having been approved by said County Attorney; and such Bidder is hereby charged with this notice.

The signer of the proposal, as Bidder, also declares that the only person, persons, company or parties interested in this proposal, are named in the proposal, that he has carefully examined the Advertisement of Bid, Solicitation Instructions, Contract Specifications, Plans, Supplementary Conditions for Federal/State Requirements, General Conditions, Special Conditions, Special Provisions and contract bond, that he or his representative has made such investigation as is necessary to determine the character and extent of the work and he proposes and agrees that if the proposal be accepted, he will contract with Hernando County, Florida in the form of contract hereto annexed, to provide the necessary labor, materials, machinery, equipment, tools or apparatus, do all the work required to complete the Contract within the time mentioned in the Contract Documents according to the requirements of Hernando County, Florida, as herein and hereinafter set forth, and furnish the required surety bonds for the following prices to wit:

Confirmed

11. Full names and addresses (proposal two) *

Pass

Please provide the full names and residences of all persons and parties interested in the foregoing bid are as follows:

If corporation, give the names and addresses of the president and secretary. If firm or partnership, the names and addresses of the members or partners. The Bidder shall list not only his name, but also the name of any person with whom Bidder has any type of agreement whereby such person's improvements,

enrichment, employment of possible benefit, whether subcontractor, materialman, agent, supplier, or employer, is contingent upon the award of the Contract to the Bidder).

PLEASE TYPE NAMES AND ADDRESSES AS REQUESTED.

Daniel Goodwin - 14341 Ponce De Leon Blvd Brooksville, FL 34601. Micheal Goodwin - 14341 Ponce De Leon Blvd Brooksville, FL 34601

12. BID GUARANTEE

Pass

Bidder has enclosed a Certified check, Cashier's Check or Bid Bond in the amount of not less than the five percent (5%) of the Total Base Bid Amount payable to the Hernando County Board of County Commissioners as a guarantee for the purpose set out in the Instructions to Bidders.

Confirmed

13. Please provide construction experience*

Pass

Overview of construction experience, including a list of projects successfully completed and indicating Owner, location, Contract value and completion date.

Goodwin Brothers has 35+ years experience in Heavy Civil Construction to include, Drainage, Roadway, Concrete, Utilities and Mining.

Business/Owner Name: Oak Hill LLC

Reference Contact Person: Burt Bennett

Reference Address: 966 Candlelight Blvd Brooksville FL 34601

Reference Phone No:352-796-9423

Reference Email Address: bbennett@Coastal-engineering.com

Project Name: Waterford 1A1

PROPOSAL DOCUMENT REPORT

ITB No. 23-CG0215/JG

Dr. Dennis Wilfong Center for Success/Infrastructure - Rebid

Project Location: Spring Hill FL

Contract Project Manager: Tom Charlow

Site Superintendent: Daniel Goodwin

Contract Amount: \$2,500,000.00

Date Project Commenced: 3/15/2018

Date of Substantial Completion: 5/25/2022

Date of Final Completion: 7/12/2022

Description of Work Performed: Constructed Drainage, Roads and Concrete work (Subdivision)

Business/Owner Name: Oak Hill LLC

Reference Contact Person: Burt Bennett

Reference Address: 966 Candlelight Blvd Brooksville FL 34601

Reference Phone No:352-796-9423

Reference Email Address: bbennett@Coastal-engineering.com

Project Name: Waterford 1A2

Project Location: Spring Hill FL

Contract Project Manager: Tom Charlow

Site Superintendent: Daniel Goodwin

Contract Amount: \$2,500,000.00

Date Project Commenced: 3/15/2018

Date of Substantial Completion: 5/25/2022

Date of Final Completion: 7/12/2022

Description of Work Performed: Constructed Drainage, Roads and Concrete work (Subdivision)

Business/Owner Name: Hernando County DPW

Reference Contact Person: Scott Nelson

Reference Address: 1525 East Jefferson St

Reference Phone No:352-754-4062

Reference Email Address: scottn@co.hernando.fl.us

Project Name: Canary and Mandrake MSBU

Project Location: Spring Hill FL

Contract Project Manager: Tom Charlow

Site Superintendent: Daniel Goodwin

Contract Amount: \$211,002.20

Date Project Commenced: 11/13/2021

Date of Substantial Completion: 1-9-2022

Date of Final Completion: 12/25/2022

Description of Work Performed: Limerock road reconstruction, stabilization, asphalt paving.

14. Experience detail*

Pass

Documentation of two (2) projects, similar in scope and complexity to this project, which have been successfully completed by the Bidder within the past seven (7) years.

Business/Owner Name: Oak Hill LLC

Reference Contact Person: Burt Bennett

Reference Address: 966 Candlelight Blvd Brooksville FL 34601

Reference Phone No:352-796-9423

Reference Email Address: bbennett@Coastal-engineering.com

Project Name: Waterford 1A1

Project Location: Spring Hill FL

Contract Project Manager: Tom Charlow

Site Superintendent: Daniel Goodwin

Contract Amount: \$2,500,000.00

Date Project Commenced: 3/15/2018

Date of Substantial Completion: 5/25/2022

Date of Final Completion: 7/12/2022

Description of Work Performed: Constructed Drainage, Roads and Concrete work (Subdivision)

Business/Owner Name: Oak Hill LLC

Reference Contact Person: Burt Bennett

Reference Address: 966 Candlelight Blvd Brooksville FL 34601

Reference Phone No:352-796-9423

Reference Email Address: bbennett@Coastal-engineering.com

Project Name: Waterford 1A2

Project Location: Spring Hill FL

Contract Project Manager: Tom Charlow

Site Superintendent: Daniel Goodwin

Contract Amount: \$2,500,000.00

Date Project Commenced: 3/15/2018

Date of Substantial Completion: 5/25/2022

Date of Final Completion: 7/12/2022

Description of Work Performed: Constructed Drainage, Roads and Concrete work (Subdivision)

15. Drug Free Workplace Certification *

Pass

I have read and attest to, in accordance with Florida Statute 287.087 (current version), hereby certify that, Publishes a written statement notifying that the unlawful manufacture, distribution, dispensing, possession or use of a controlled substance is prohibited in the workplace named above, and specifying actions that will be taken against violations of such prohibition.

Informs employees about the dangers of drug abuse in the workplace, the firm's policy of maintaining a drug free working environment, and available drug counseling, rehabilitation, and employee assistance programs, and the penalties that may be imposed upon employees for drug use violations.

Gives each employee engaged in providing commodities or contractual services that are under proposal a copy of the statement specified above.

Notifies the employees that as a condition of working on the commodities or contractual services that are under proposal, the employee will abide by the terms of the statement and will notify the employer of any conviction of, pleas of guilty or nolo contendere to, any violation of Chapter 893, or of any controlled substance law of the State of Florida or the United States, for a violation occurring in the workplace, no later

than five (5) days after such conviction, and requires employees to sign copies of such written statement to acknowledge their receipt.

Imposes a sanction on, or requires the satisfactory participation in, a drug abuse assistance or rehabilitation program, if such is available in the employee's community, by any employee who is so convicted.

Makes a good faith effort to continue to maintain a drug free workplace through the implementation of the Drug Free Workplace Program.

"As a person authorized to sign this statement, I certify that the above named business, firm or corporation complies fully with the requirements set forth herein".

Please Confirm that you have read and attest to Download Drug Free Workplace Certificate

Confirmed

16. Affidavit of Non Collusion and of Non-Interest of Hernando County Employees*

Pass

Affidavit of Non Collusion and of Non-Interest of Hernando County Employees

Certification that Vendor/Contractor affirms that the bid/proposal presented to the Owner is made freely, and without any secret agreement to commit a fraudulent, deceitful, unlawful or wrongful act of collusion.

I have read and attest that I am the Vendor/Contractor in the above bid/proposal, that the only person or persons interested in said proposal are named therein; that no officer, employee or agent of the Hernando County Board of County Commissioners (BOCC) or of any other Vendor/Contractor is interested in said bid/proposal; and that affiant makes the above bid/proposal with no past or present collusion with any other person, firm or corporation.

Please confirm that you have read and attest to Affidavit of Non Collusion and of Non-Interest of Hernando County Employees

Confirmed

17. Sworn Statement

SWORN STATEMENT 287.133 (3) (A)*

Pass

I have read and attest that I understand that a "public entity crime" as defined in Paragraph 287.133 (1)(g), Florida Statutes (current version), means a violation of any public entity or with an agency or political subdivision of any other state or of the United States, including, but not limited to, any proposal or contract for goods or services to be provided to any public entity or an agency or political subdivision of any other state or of the United States and involving antitrust, fraud, theft, bribery, collusion, racketeering, conspiracy, or material misrepresentation.

I have read and attest that I understand that "convicted" or "conviction" as defined in Paragraph 287.133 (1)(b), Florida Statutes (current version), means a finding of guilt or a conviction of a public entity crime, with or without an adjudication of guilt, in any Federal or State trial court of record relating to charges brought by indictment or information after July 1, 1989, as a result of a jury verdict, non-jury trial, or entry of a plea of guilty or nolo contendere.

I have read and attest that I understand that an "affiliate" as defined in Paragraph 287.133 (1)(a), Florida Statutes (current version), means:

- A. A predecessor or successor of a person convicted of a public entity crime; or
- B. An entity under the control of any natural person who is active in the management of the entity and who has been convicted of a public entity crime. The term "affiliate" includes those officers, directors, executives, partners, shareholders, employees, members, and agents who are active in the management of an affiliate. The ownership by one (1) person of shares constituting a controlling interest in another person, or a pooling of equipment or income among persons when not for fair market value under an arm's length agreement, shall be a prima facie case that one (1) person controls another person. A person who knowingly enters into a joint venture with a person who has been convicted of a public entity crime in Florida during the preceding thirty-six (36) months shall be considered an affiliate.

I have read and attest that I understand that a "person" as defined in Paragraph 287.133(1)(e), Florida Statutes (current version), means any natural person or entity organized under the laws of any state or of the United States with the legal power to enter into a binding contract and which proposals or applies to proposal on contracts for the provisions of goods or services let by a public entity, or which otherwise transacts or applies to transact business with a public entity. The term "person" includes those officers, directors, executives, partners, shareholders, employees, members, and agents who are active in management of an entity.

I have read and attest that based on information and belief, the statement which I have confirmed below is true in relation to the entity submitting this sworn statement:

_____ [attach a copy of the final order].

I UNDERSTAND THAT THE SUBMISSION OF THIS FORM TO THE CONTRACTING OFFICER FOR THE PUBLIC ENTITY IDENTIFIED IN PARAGRAPH ONE (1) ABOVE IS FOR THAT PUBLIC ENTITY ONLY AND, THAT THIS FORM IS VALID THROUGH DECEMBER 31, OF THE CALENDAR YEAR IN WHICH IT IS FILED. I ALSO UNDERSTAND THAT I AM REQUIRED TO INFORM THE PUBLIC ENTITY PRIOR TO ENTERING INTO A CONTRACT.

Neither the entity submitting this sworn statement, nor any of its officers, directors, executives, partners, shareholders, employees, members, or agents who are active in the management of the entity, nor any affiliate of the entity has been charged with and convicted of a public entity crime subsequent to July 1, 1989.

IF YOU CHOOSE OPTION 3, PLEASE ATTACH A COPY OF THE FINAL ORDER

If you choose option 3, please attach a copy of the final order

The entity submitting this sworn statement, or one (1) or more of its officers, directors, executives, partners, shareholders, employees, members, or agents who are active in the management of the entity, or an affiliate of the entity has been charged with and convicted of a public entity crime subsequent to July 1, 1989. However, there has been a subsequent proceeding before a Hearing Officer of the State of Florida, Division of Administrative Hearings and the Final Order entered by the Hearing Officer determined that it was not in the public interest to place the entity submitting this sworn statement on the convicted Vendor/Contractor list

Please attach a copy of the final order

No response submitted

18. Authorized Signatures/Negotiators

AUTHORIZED SIGNATURES/NEGOTIATORS *

Pass

Please provide the information to support the statement below:

The Vendor/Contractor represents that the following persons are authorized to sign and/or negotiate contracts and related documents to which the Vendor/Contractor will be duly bound:

Name(s)

Title(s)

Phone no (s)

Daniel Goodwin

President

352-796-0149

Eddie Goodwin

Vice President

352-796-0149

David Goodwin

Treasurer

352-796-0149

Micheal Goodwin

Secretary

352-796-0149

Tom Charlow

Estimator/Project Manager

352-796-0149

TYPE OF ORGANIZATION *

Pass

Please select your organization type:

Corporation

COMPANY ID*

Pass

Please Provide Your:

State of Incorporation and

Federal I.D. NO.

Florida 59-2827531

W9 FORM *

Pass

Please upload your company's W9 information

Goodwin_Brothers_W-9.pdf

ACH ELECTRONIC PAYMENT*

Pass

An ACH electronic payment method is offered as an alternative to a payment by physical check. Please select one of the options.

Yes, ACH electronic payment method is acceptable.

19. E-VERIFY CERTIFICATION

E-VERIFY CERTIFICATION *

Pass

Vendor/Contractor acknowledges and agrees to the following:

Vendor/Contractor shall utilize the U.S. Department of Homeland Security's E-Verify system, in accordance with the terms governing use of the system, to confirm the employment eligibility of:

All persons employed by the Vendor/Contractor during the term of the Contract to perform employment duties within Florida; and

All persons, including subcontractors, assigned by the Vendor/Contractor to perform work pursuant to the Contract with the department.

Confirmed

20. CONSTRUCTION CONTRACTOR QUALIFICATION SUBMITTAL REQUIREMENTS

REFERENCES *

Pass

Bidder must provide a minimum of **three (3)** references in format shown below. References must be individuals that can be readily contacted and have first-hand knowledge of the Bidder's performance on the specific project performed by the Bidder. Each reference project must meet the following criteria:

Project at Substantial Completion or completed within the last seven (7) years.

Similar in size, dollar value and scope as this project.

Please provide information for 3 required References:

Business/Owner Name

Reference Contact Person

Reference Address

Reference Phone No.

Reference Email Address

Project Name
Project Location
Contract Project Manager
Site Superintendent
Contract Amount
Date Project Commenced
Date of Substantial Completion
Date of Final Completion
Description of Work Performed

Note: Experience shall be related to successfully completed projects within the last seven (7) years (i.e. the project must have been Substantially Complete within seven (7) years of the due date of this ITB. Only projects that are complete or substantially complete as of the bid due date will be considered).

By submitting this information, I certify that the qualifications questionnaire information is true and correct to the best of my knowledge.

Business/Owner Name: Oak Hill LLC
Reference Contact Person: Burt Bennett
Reference Address: 966 Candlelight Blvd Brooksville FL 34601
Reference Phone No:352-796-9423
Reference Email Address: bbennett@Coastal-engineering.com

Project Name: Waterford 1A1
Project Location: Spring Hill FL
Contract Project Manager: Tom Charlow
Site Superintendent: Daniel Goodwin
Contract Amount: \$2,500,000.00
Date Project Commenced: 3/15/2018
Date of Substantial Completion: 5/25/2022
Date of Final Completion: 7/12/2022
Description of Work Performed: Constructed Drainage, Roads and Concrete work (Subdivision)

PROPOSAL DOCUMENT REPORT

ITB No. 23-CG0215/JG

Dr. Dennis Wilfong Center for Success/Infrastructure - Rebid

Business/Owner Name: Oak Hill LLC

Reference Contact Person: Brian Malmberg

Reference Address: 966 Candlelight Blvd Brooksville FL 34601

Reference Phone No:352-796-9423

Reference Email Address: bbennett@Coastal-engineering.com

Project Name: Waterford 1A2

Project Location: Spring Hill FL

Contract Project Manager: Tom Charlow

Site Superintendent: Daniel Goodwin

Contract Amount: \$2,500,000.00

Date Project Commenced: 3/15/2018

Date of Substantial Completion: 5/25/2022

Date of Final Completion: 7/12/2022

Description of Work Performed: Constructed Drainage, Roads and Concrete work (Subdivision)

Business/Owner Name: Hernando County DPW

Reference Contact Person: Scott Nelson

Reference Address: 1525 East Jefferson St

Reference Phone No:352-754-4062

Reference Email Address: scottn@co.hernando.fl.us

Project Name: Canary and Mandrake MSBU

Project Location: Spring Hill FL

Contract Project Manager: Tom Charlow

Site Superintendent: Daniel Goodwin

Contract Amount: \$211,002.20

Date Project Commenced: 11/13/2021

Date of Substantial Completion: 1-9-2022

Date of Final Completion: 12/25/2022

Description of Work Performed: Limerock road reconstruction, stabilization, asphalt paving.

KEY SUBCONTRACTORS*

Pass

Each Bidder must submit with its response a list of subcontractors who will perform the work in each of the following categories (key subcontractors). List the name of the proposed subcontractor, or "Bidder" if the Bidder will perform the work, after each work category:

Example:

- (1) Clearing, grubbing and earthwork construction
- (2) Storm drainage construction
- (3) Sanitary sewer and water distribution construction
- (4) Roadway construction
- (5) Gopher Tortoise survey, permitting and relocation
- (6) Pre/Post video
- (7) Sodding and seeding

If no subcontractors will be employed please state "NONE"

(1) Clearing, grubbing and earthwork construction

Goodwin Brothers Construction

(2) Storm drainage construction

Goodwin Brothers Construction

(3) Sanitary sewer and water distribution construction

CBS Underground

(4) Roadway construction

Goodwin Construction

(5) Gopher Tortoise survey, permitting and relocation

Coastal Engineering

(6) Pre/Post video

Goodwin Brothers Construction

(7) Sodding and seeding

J & J Sod

VENDOR/CONTRACTOR'S LICENSE*

Pass

The Bidder must be a registered to do business in the State of Florida. **All Bidder's and/or subcontractors performing work requiring a specialty license must be licensed in the State of Florida.** This includes but is not limited to electrical and mechanical trades, as well as any other earthwork Contractor on the Bidder's team. Provide license information (as required in Paragraph 27) below for Bidder and all subcontractors identified herein.

Classification

Issuing Government License

Issue Date:

License Number:

Underground Utility and Excavation

State of Florida

7/28/2008

CUC1224603

ORGANIZATION CHART:*

Pass

Bidder must provide an organization chart showing Bidder's team identifying specific responsibilities of Bidder and subcontractors.

Goodwin_Brothers_Org_Chart.pdf

PROJECT MANAGER AND SUPERINTENDENT QUALIFICATIONS:*

Pass

Bidder must provide resumes of Project Manager and Superintendent listing qualifications, experience, education and training. The Project Manager and Superintendent must have adequate experience, generally considered as a working Project Manager/Superintendent on a minimum of two (2) projects, similar in size and scope to the Dr. Dennis Wilfong Center for Success/Infrastructure - Rebid, within the past seven (7) years.

Jamie_Lewis_Superintendent.pdf Daniel_R_Goodwin_Resume_Senior_Project_Manager.pdf

BIDDER/KEY SUBCONTRACTOR SPECIFIC QUALIFICATIONS:*

Pass

Bidder must demonstrate Bidder's/Key subcontractor's experience and expertise in the tasks provided below and at the minimum identified criteria. Specific projects, locations and Contractor who performed work must be provided.

- A. Document prior experience in construction of earthwork projects involving site clearing and excavating.
- B. Document prior experience in construction of sanitary sewer and water distribution.
- C. Document prior experience in construction of storm drainage retention areas.
- D. Document prior experience in road construction.

Goodwin Brothers, County projects Flicker Road, Area A, B, C, E, F, G, H, I MSBU Road construction and paving South Brooksville Drainage improvements BMP 6, Shoal Line Road paving. Tilby Crossing Phase 1,2,3, Cortez Oaks Phase 1A1,1A2, Brooksville Living Facility, SR 50/I75 Frontage Road construction, City Of Brooksville Paving Projects 2021-2022, Anderson Snow Road Forcemain, Coronado and Godfrey Drainage Improvements, Hope Hill Rd resurfacing.

CBS Underground, Tilby Crossing Phase 1,2,3, Cortez Oaks Phase 1A1,1A2, Brooksville Living Facility, SR 50/I75 Frontage Road construction, City Of Brooksville Paving Projects 2021-2022, Anderson Snow Road Forcemain, Coronado and Godfrey Drainage Improvements.

AKCA Inc, County projects Flicker Road, Area A, B, C, E, F, G, H, I MSBU Road construction and paving South Brooksville Drainage improvements BMP 6, Shoal Line Road paving. Tilby Crossing Phase 1,2,3, Cortez Oaks Phase 1A1,1A2, Brooksville Living Facility, SR 50/I75 Frontage Road construction, City Of Brooksville Paving Projects 2021-2022, Anderson Snow Road Forcemain, Coronado and Godfrey Drainage Improvements, Hope Hill Rd resurfacing.

Coastal Engineering, South Brooksville Drainage improvements BMP 6, Shoal Line Road paving. Tilby Crossing Phase 1,2,3, Cortez Oaks Phase 1A1,1A2, Brooksville Living Facility, SR 50/I75 Frontage Road construction, City Of Brooksville Paving Projects 2021-2022, Anderson Snow Road Forcemain, Coronado and Godfrey Drainage Improvements, Hope Hill Rd resurfacing.

J&J SOD, County projects Flicker Road, Area A, B, C, E, F, G, H, I MSBU Road construction and paving South Brooksville Drainage improvements BMP 6, Shoal Line Road paving. Tilby Crossing Phase 1,2,3, Cortez Oaks Phase 1A1,1A2, Brooksville Living Facility, SR 50/I75 Frontage Road construction, City Of Brooksville Paving Projects 2021-2022, Anderson Snow Road Forcemain, Coronado and Godfrey Drainage Improvements, Hope Hill Rd resurfacing.

Road Safe Traffic Systems, SR 50/I75 Frontage Road construction, City Of Brooksville Paving Projects 2021-2022, Anderson Snow Road Forcemain, Coronado and Godfrey Drainage Improvements, Hope Hill Rd resurfacing.

21. VENDOR/CONTRACTOR'S LICENSE

VENDOR/CONTRACTOR'S LICENSE*

Pass

Please upload all contractors and subcontractors license(s) required for this project.

Goodwin_lic.pdf
Chucks_Stokes_Electric_State_Lic_EC0002202_Exp_8-2024.pdf
CBS_Underground_State_Lic_CUC1225138_Exp_8-2024.pdf
Chuck's_Fire_License_Exp_06-30-2024.pdf

22. Additional Required Forms

TRENCH SAFETY ACT COMPLIANCE *

Pass

Please download the below documents, complete, and upload.

- [Trench Safety Act Complian...](#)

Trench_Safety.pdf

CORPORATE AFFIDAVIT *

Pass

Please download the below documents, complete, and upload.

- [Corporate Affidavit.pdf](#)

Goodwin_Corporate_Affidavit.pdf

BID BOND FORM *

Pass

Please download the below documents, complete, and upload.

- [BID BOND.pdf](#)

Bid_Bond.pdf

VENDOR CERTIFICATION REGARDING SCRUTINIZED COMPANIES*

Pass

Section 287.135 (Current Edition), Florida Statutes, prohibits agencies from contracting with companies for goods or services of \$1,000,000.00 or more, that are on either the Scrutinized Companies with Activities in Sudan List, the Scrutinized Companies with Activities in the Iran Petroleum Energy Sector Lists which are created pursuant to s. 215.473 F.S. (Current Edition), or the Scrutinized Companies that Boycott Israel List,

created pursuant to s. 215.4725 F.S. (Current Edition), or companies that are engaged in a boycott of Israel or companies engaged in business operations in Cuba or Syria.

As the person authorized to bind on behalf of respondent, I hereby certify that the company identified above in the section entitled "Respondent Vendor Name" is not listed on either the Scrutinized Companies with Activities in Sudan List or the Scrutinized Companies with Activities in the Iran Petroleum Energy Sector List, or the Scrutinized Companies that Boycott Israel List. I further certify that the company is not engaged in a boycott of Israel. I understand that pursuant to section 287.135 (Current Edition), Florida Statutes, the submission of a false certification may subject company to civil penalties, attorney's fees, and/or costs and does not have business operations in Cuba or Syria.

I have read and attest that I confirm the above is acknowledged.

Confirmed

23. HERNANDO COUNTY EMPLOYMENT DISCLOSURE CERTIFICATION STATEMENT

IS ANY OFFICER, PARTNER, DIRECTOR, PROPRIETOR, ASSOCIATE OR MEMBER OF THE BUSINESS ENTITY A FORMER EMPLOYEE OF HERNANDO COUNTY WITHIN THE LAST TWO (2) YEARS? *

Pass

No

IS ANY OFFICER, PARTNER, DIRECTOR, PROPRIETOR, ASSOCIATE OR MEMBER OF THE BUSINESS ENTITY A RELATIVE OR MEMBER OF THE HOUSEHOLD OF A CURRENT HERNANDO COUNTY EMPLOYEE THAT HAD OR WILL HAVE ANY INVOLVEMENT WITH THIS PROCUREMENT OR CONTRACT AUTHORIZATION?*

Pass

No

RELATIVES AND FORMER HERNANDO COUNTY EMPLOYEES - ROLES AND SIGNATURES

If you answered yes to the either of the two prior questions regarding relatives or Hernando employees, please download the below documents, complete, and upload.

- [HC Employment Disclosure Ce...](#)

No response submitted

24. Vendor Survey

VENDOR SURVEY *

Pass

Please provide information on where you received the knowledge of the bid/request for Proposals (mark all that apply):

County's eProcurement Portal (Open Gov Procurement)

VENDOR SURVEY - OTHER

If you choose Other please list how you received the knowledge of the bid/request for Proposals.

No response submitted

SAMPLE CONSTRUCTION AGREEMENT *

Pass

Sample Construction Agreement for your review, including attachments that will be required after award.

- [Sample Construction Agreeeme...](#)
- [Documents required after Aw...](#)

Documents_required_after_Award_(3).pdfSample_Construction_Agreement_(7).pdf

FEDERAL/STATEFORMS*

Pass

Please download the below documents, complete, and upload.

- [Florida Conflict of Interes...](#)
- [Felony tax certification pl...](#)
- [DBE-SUB Statement Form.pdf](#)
- [GOOD FAITH EFFORTS-with OSD...](#)
- [State Certification for Dis...](#)
- [Exp 2-18-2025 Standard Form...](#)
- [Suspension Debarment Certif...](#)

Federal_Requirement_docs.pdf

SOLICITATION-OFFER-AWARD*

Pass

Please download the below document, complete Offer section, and upload.

- [Solicitation - Offer - Awar...](#)

Solicitation_Offer_Goodwin.pdf

PRICE TABLES

GENERAL CONDITIONS

Line Item	Description	Quantity	Unit of Measure	Unit Cost	Total
1	Mobilization	1	LS	\$23,575.00	\$23,575.00
2	Insurance, Permits, and Performance & Payment Bond	1	LS	\$23,365.00	\$23,365.00
3	Maintenance of Traffic	1	LS	\$3,450.00	\$3,450.00
4	Survey Layout/As-built	1	LS	\$28,129.00	\$28,129.00
5	Pre/Post Video	1	LS	\$575.00	\$575.00
6	Erosion Sediment Control (includes NPDES Permit/Inspection Report/NOT	1	LS	\$1,725.00	\$1,725.00
TOTAL					\$80,819.00

CLEARING, GRUBBING AND EARTHWORK

Line Item	Description	Quantity	Unit of Measure	Unit Cost	Total
7	Clearing/Grubbing (includes DRA & Floodplain Comp)	20	AC	\$3,910.00	\$78,200.00
8	Embankment Excavation, Filling and Grading	1	LS	\$75,977.78	\$75,977.78
9	Temporary Construction Access	1	LS	\$1,060.00	\$1,060.00
10	Silt Fence Installation and Removal	5,800	LF	\$1.32	\$7,656.00
TOTAL					\$162,893.78

STORM DRAINAGE

Line Item	Description	Quantity	Unit of Measure	Unit Cost	Total
11	15" RCP	68	LF	\$56.22	\$3,822.96
12	18" RCP	508	LF	\$60.40	\$30,683.20
13	24" RCP	92	LF	\$86.53	\$7,960.76

PROPOSAL DOCUMENT REPORT

ITB No. 23-CG0215/JG

Dr. Dennis Wilfong Center for Success/Infrastructure - Rebid

Line Item	Description	Quantity	Unit of Measure	Unit Cost	Total
14	29" x 45" ERCP	104	LF	\$244.49	\$25,426.96
15	30" RCP	266	LF	\$128.21	\$34,103.86
16	42" RCP	266	LF	\$216.80	\$57,668.80
17	48" RCP	334	LF	\$263.40	\$87,975.60
18	FDOT Gutter Type V Inlet	6	EA	\$5,298.13	\$31,788.78
19	FDOT Type C Inlet	1	EA	\$3,349.02	\$3,349.02
20	FDOT Type F Inlet	2	EA	\$10,516.58	\$21,033.16
21	FDOT Type G Inlet	1	EA	\$8,386.58	\$8,386.58
22	FDOT Type 7 Inlet	1	EA	\$8,011.28	\$8,011.28
23	24" MES	3	EA	\$902.75	\$2,708.25
24	29" x 45" MES	2	EA	\$4,110.10	\$8,220.20
25	48" MES	1	EA	\$5,709.75	\$5,709.75
26	Rip Rap	650	SF	\$5.52	\$3,588.00
27	Concrete Weir with Skimmer	1	EA	\$12,150.95	\$12,150.95
28	Sod DRA Side Slopes	13,800	SY	\$2.65	\$36,570.00
29	Seed and Mulch DRA	56,000	SY	\$0.30	\$16,800.00
TOTAL					\$405,958.11

SANITARY SEWER

Line Item	Description	Quantity	Unit of Measure	Unit Cost	Total
30	8" PVC SDR 26 (0'-6')	350	LF	\$52.13	\$18,245.50
31	8" PVC SDR 26 (6'-8')	350	LF	\$57.88	\$20,258.00
32	8" PVC SDR 26 (8'-10')	222	LF	\$60.42	\$13,413.24
33	Manholes (0'-6')	2	EA	\$6,616.28	\$13,232.56

PROPOSAL DOCUMENT REPORT

ITB No. 23-CG0215/JG

Dr. Dennis Wilfong Center for Success/Infrastructure - Rebid

Line Item	Description	Quantity	Unit of Measure	Unit Cost	Total
34	Manholes (6'-8')	1	EA	\$8,339.71	\$8,339.71
35	Manholes (8'-10')	1	EA	\$9,803.75	\$9,803.75
36	LS Receiving Manhole (8'-10') Coated	1	EA	\$14,137.39	\$14,137.39
37	Pump Station Complete	1	LS	\$460,000.00	\$460,000.00
38	Gravity Sewer Testing	922	LF	\$9.05	\$8,344.10
39	4" PVC C-900 Force Main	1,840	LF	\$24.75	\$45,540.00
40	4" MJ 45 Ftg with Restraints	10	EA	\$666.61	\$6,666.10
41	4" x 6" Tapping Sleeve and Valve	1	EA	\$7,506.83	\$7,506.83
42	Force Main Pressure Testing	1,840	LF	\$2.88	\$5,299.20
43	Stabilized Roadway	930	SY	\$10.56	\$9,820.80
TOTAL					\$640,607.18

WATER DISTRIBUTION

Line Item	Description	Quantity	Unit of Measure	Unit Cost	Total
44	8" PVC C-900 Water Main	100	LF	\$75.67	\$7,567.00
45	12" PVC C-900 Water Main	1,150	LF	\$104.42	\$120,083.00
46	12" MJ 45 Ftg with Restraints	4	EA	\$2,107.63	\$8,430.52
47	12" x 4" Tee Ftg with Restraints	3	EA	\$1,331.11	\$3,993.33
48	12" x 8" Tee Ftg with Restraints	3	EA	\$1,461.97	\$4,385.91
49	12" x 8" Cross Ftg with Restraints	1	EA	\$1,645.65	\$1,645.65
50	4" Gate Valve with Restraints	3	EA	\$2,542.75	\$7,628.25
51	8" Gate Valve with Restraints	5	EA	\$4,132.79	\$20,663.95
52	12" Gate Valve with Restraints	2	EA	\$7,130.00	\$14,260.00
53	4" End Cap with Restraints	3	EA	\$286.30	\$858.90

PROPOSAL DOCUMENT REPORT

ITB No. 23-CG0215/JG

Dr. Dennis Wilfong Center for Success/Infrastructure - Rebid

Line Item	Description	Quantity	Unit of Measure	Unit Cost	Total
54	8" End Cap with Restraints	3	EA	\$445.91	\$1,337.73
55	Temporary Water Service Connection (HCUD Detail #42)	1	EA	\$1,725.00	\$1,725.00
56	Cut and Connect to Existing Water Main	4	EA	\$8,674.07	\$34,696.28
57	Water Testing/Chlorination	1,250	LF	\$4.27	\$5,337.50
TOTAL					\$232,613.02

ROAD CONSTRUCTION

Line Item	Description	Quantity	Unit of Measure	Unit Cost	Total
58	12" Type B Stabilized Subgrade	2,920	SY	\$2.95	\$8,614.00
59	8" Limerock Base	2,920	SY	\$13.35	\$38,982.00
60	1-5" Type SP-12.5 Asphalt (Traffic Level C)	2,920	SY	\$10.17	\$29,696.40
61	1" Type SP-9.5 Asphalt (Traffic Level C)	2,920	SY	\$6.90	\$20,148.00
62	Drop Curb	1,100	LF	\$15.53	\$17,083.00
63	Valley Gutter	130	LF	\$28.75	\$3,737.50
64	Sod R/W	7,600	SY	\$2.65	\$20,140.00
65	5' Concrete Sidewalk (3,000 psi/4" thick)	19,332	SF	\$7.48	\$144,603.36
66	Curb Ramp with Tactile Surface	4	EA	\$747.50	\$2,990.00
67	10' x 10' Concrete Pad (3,000 psi/4" thick)	2	EA	\$977.50	\$1,955.00
68	Seed and Mulch R/W, Easements	8,900	SY	\$0.30	\$2,670.00
69	Striping/Signage	1	LS	\$6,376.75	\$6,376.75
TOTAL					\$296,996.01

GOPHER TORTOISE RELOCATION

PROPOSAL DOCUMENT REPORT

ITB No. 23-CG0215/JG

Dr. Dennis Wilfong Center for Success/Infrastructure - Rebid

Line Item	Description	Quantity	Unit of Measure	Unit Cost	Total
70	Gopher Tortoise Survey & Permitting	1	LS	\$3,268.30	\$3,268.30
71	Gopher Tortoise Burrow Excavation	18	EA	\$230.00	\$4,140.00
72	Gopher Tortoise Relocation	10	EA	\$6,737.08	\$67,370.80
TOTAL					\$74,779.10



Ron DeSantis, Governor

Melanie S. Griffin, Secretary



STATE OF FLORIDA
DEPARTMENT OF BUSINESS AND PROFESSIONAL REGULATION

ELECTRICAL CONTRACTORS' LICENSING BOARD

THE ELECTRICAL CONTRACTOR HEREIN IS CERTIFIED UNDER THE
PROVISIONS OF CHAPTER 489, FLORIDA STATUTES

STOKES, CHARLES B JR

CHUCK'S STOKES ELECTRIC OF CENTRAL FLA INC
1734 N MAGNOLIA AVE
OCALA FL 34478

LICENSE NUMBER: EC0002202

EXPIRATION DATE: AUGUST 31, 2024

Always verify licenses online at MyFloridaLicense.com



Do not alter this document in any form.

This is your license. It is unlawful for anyone other than the licensee to use this document.



Ron DeSantis, Governor

Melanie S. Griffin, Secretary



STATE OF FLORIDA
DEPARTMENT OF BUSINESS AND PROFESSIONAL REGULATION

CONSTRUCTION INDUSTRY LICENSING BOARD

THE UNDERGROUND UTILITY & EXCAVATION CO HEREIN IS CERTIFIED UNDER THE
PROVISIONS OF CHAPTER 489, FLORIDA STATUTES

STOKES, CHARLES B JR

CBS UNDERGROUND INC.
1734 N MAGNOLIA AVE
OCALA FL 34475

LICENSE NUMBER: CUC1225138

EXPIRATION DATE: AUGUST 31, 2024

Always verify licenses online at MyFloridaLicense.com



Do not alter this document in any form.

This is your license. It is unlawful for anyone other than the licensee to use this document.

Jimmy Patronis
CHIEF FINANCIAL OFFICER

Julius Halas
DIVISION DIRECTOR



John Gatlin
BUREAU CHIEF

Catherine Thrasher
SAFETY PROGRAM MANAGER

FLORIDA DEPARTMENT OF FINANCIAL SERVICES

DIVISION OF STATE FIRE MARSHAL

200 EAST GAINES STREET - Tallahassee, Florida 32399-0342

Tel. 850-413-3644

CERTIFICATE OF COMPETENCY
OFFICIAL COPY

THIS CERTIFIES THAT: Charles B Stokes, Jr.
1734 N Magnolia Ave
Ocala FL 34475

BUSINESS ORGANIZATION: CBS Underground, Inc

Contractor V means a contractor whose business is limited to the execution of contracts requiring the ability to fabricate, install, inspect, alter, repair and service the underground piping for a fire protection system using water as the extinguishing agent beginning at the point of service as defined in the act and ending no more than 1 foot above the finished floor.

Issue Date: 07/01/2022
Type: 09
Class: 14
County: Marion
License/Permit #: FPC14-000103
Expiration Date: 06/30/2024



Handwritten signature of Jimmy Patronis in cursive.

Chief Financial Officer



Ron DeSantis, Governor

Melanie S. Griffin, Secretary



**STATE OF FLORIDA
DEPARTMENT OF BUSINESS AND PROFESSIONAL REGULATION**

CONSTRUCTION INDUSTRY LICENSING BOARD

THE UNDERGROUND UTILITY & EXCAVATION CO HEREIN IS CERTIFIED UNDER THE
PROVISIONS OF CHAPTER 489, FLORIDA STATUTES

GOODWIN, DAVID REECE SR

GOODWIN BROS CONSTRUCTION INC
14341 PONCE DE LEON BLVD
BROOKSVILLE FL 34601

LICENSE NUMBER: CUC1224603

EXPIRATION DATE: AUGUST 31, 2024

Always verify licenses online at MyFloridaLicense.com



Do not alter this document in any form.

This is your license. It is unlawful for anyone other than the licensee to use this document.



Request for Taxpayer Identification Number and Certification

Give Form to the requester. Do not send to the IRS.

▶ Go to www.irs.gov/FormW9 for instructions and the latest information.

1 Name (as shown on your income tax return). Name is required on this line; do not leave this line blank.
Goodwin Bros Construction, Inc

2 Business name/disregarded entity name, if different from above

3 Check appropriate box for federal tax classification of the person whose name is entered on line 1. Check only **one** of the following seven boxes.

Individual/sole proprietor or single-member LLC

C Corporation

S Corporation

Partnership

Trust/estate

Limited liability company. Enter the tax classification (C=C corporation, S=S corporation, P=Partnership) ▶ _____

Note: Check the appropriate box in the line above for the tax classification of the single-member owner. Do not check LLC if the LLC is classified as a single-member LLC that is disregarded from the owner unless the owner of the LLC is another LLC that is **not** disregarded from the owner for U.S. federal tax purposes. Otherwise, a single-member LLC that is disregarded from the owner should check the appropriate box for the tax classification of its owner.

Other (see instructions) ▶ _____

4 Exemptions (codes apply only to certain entities, not individuals; see instructions on page 3):

Exempt payee code (if any) _____

Exemption from FATCA reporting code (if any) _____

(Applies to accounts maintained outside the U.S.)

5 Address (number, street, and apt. or suite no.) See instructions.
PO BOX 1689

6 City, state, and ZIP code
Brooksville, FL 34605

7 List account number(s) here (optional)

Requester's name and address (optional)

Print or type. See Specific Instructions on page 3.

Part I Taxpayer Identification Number (TIN)

Enter your TIN in the appropriate box. The TIN provided must match the name given on line 1 to avoid backup withholding. For individuals, this is generally your social security number (SSN). However, for a resident alien, sole proprietor, or disregarded entity, see the instructions for Part I, later. For other entities, it is your employer identification number (EIN). If you do not have a number, see *How to get a TIN*, later.

Note: If the account is in more than one name, see the instructions for line 1. Also see *What Name and Number To Give the Requester* for guidelines on whose number to enter.

Social security number

			-					
--	--	--	---	--	--	--	--	--

or

Employer identification number

5	9	-	2	8	2	7	5	3	1
---	---	---	---	---	---	---	---	---	---

Part II Certification

Under penalties of perjury, I certify that:

- The number shown on this form is my correct taxpayer identification number (or I am waiting for a number to be issued to me); and
- I am not subject to backup withholding because: (a) I am exempt from backup withholding, or (b) I have not been notified by the Internal Revenue Service (IRS) that I am subject to backup withholding as a result of a failure to report all interest or dividends, or (c) the IRS has notified me that I am no longer subject to backup withholding; and
- I am a U.S. citizen or other U.S. person (defined below); and
- The FATCA code(s) entered on this form (if any) indicating that I am exempt from FATCA reporting is correct.

Certification instructions. You must cross out item 2 above if you have been notified by the IRS that you are currently subject to backup withholding because you have failed to report all interest and dividends on your tax return. For real estate transactions, item 2 does not apply. For mortgage interest paid, acquisition or abandonment of secured property, cancellation of debt, contributions to an individual retirement arrangement (IRA), and generally, payments other than interest and dividends, you are not required to sign the certification, but you must provide your correct TIN. See the instructions for Part II, later.

Sign Here Signature of U.S. person ▶ 

Date ▶ **11/9/2023**

General Instructions

Section references are to the Internal Revenue Code unless otherwise noted.

Future developments. For the latest information about developments related to Form W-9 and its instructions, such as legislation enacted after they were published, go to www.irs.gov/FormW9.

Purpose of Form

An individual or entity (Form W-9 requester) who is required to file an information return with the IRS must obtain your correct taxpayer identification number (TIN) which may be your social security number (SSN), individual taxpayer identification number (ITIN), adoption taxpayer identification number (ATIN), or employer identification number (EIN), to report on an information return the amount paid to you, or other amount reportable on an information return. Examples of information returns include, but are not limited to, the following.

- Form 1099-INT (interest earned or paid)

- Form 1099-DIV (dividends, including those from stocks or mutual funds)
 - Form 1099-MISC (various types of income, prizes, awards, or gross proceeds)
 - Form 1099-B (stock or mutual fund sales and certain other transactions by brokers)
 - Form 1099-S (proceeds from real estate transactions)
 - Form 1099-K (merchant card and third party network transactions)
 - Form 1098 (home mortgage interest), 1098-E (student loan interest), 1098-T (tuition)
 - Form 1099-C (canceled debt)
 - Form 1099-A (acquisition or abandonment of secured property)
- Use Form W-9 only if you are a U.S. person (including a resident alien), to provide your correct TIN.

If you do not return Form W-9 to the requester with a TIN, you might be subject to backup withholding. See *What is backup withholding*, later.

GOODWIN BROTHER CONSTRUCTION ORGANIZATION CHART

DANIEL GOODWIN PRESIDENT/SENIOR PROJECT MANAGER

TOM CHARLOW ESTIMATOR/PROJECT MANAGER

JAMIE LEWIS PROJECT SUPERINTENDENT

JENNIFER DELUCCO OFFICE ADMINISTRATOR

SUB-CONTRACTORS

COASTAL ENGINEERING -SURVEY

J&J SOD – SODDING

ROAD SAFE TRAFFIC SYSTEMS – MOT Signage and Flaggers When needed

Gopher Tortoise Relocation – Coastal Engineering

Striping – AKCA

Asphalt – Goodwin Brothers Construction

James D. Lewis
105 Florida Avenue
Brooksville, FL 34601
(352) 678-1770

EDUCATION

Attended Hernando High School Thru 1981.

SPECIAL SKILLS/ ABILITIES

Proficient at design layout, Installation quantification for billing, maintenance of traffic operations, FDOT Policy & Procedures, Ability to run various types of Heavy Equipment, Versed in the use of electronics for special paving and super pave asphalt operations, and job site coordination.

PROFESSIONAL EXPERIENCE

Asphalt Foreman

- Goodwin Bros. Co. (April 2015- Present)

Run a 5 man crew, Responsible for overseeing job production, Operating Paving & Heavy Equipment, Daily & Weekly Timesheets, job layout, Communication with local inspectors.

Foreman

- Smith & Edwards Construction, Inc. (October 2014- April 2015)

Run a 6 man crew doing concrete slabs, sidewalks, flumes, staking out jobs.

Asphalt Foreman

- Cheyenne Asphalt (November 2012- September 2014)

Run a 6 man Lee boy crew, specialize in small parking lots, subdivisions, driveways, Seal Coating and Striping. Responsible for setting up trucks, Coordinating all job duties, and Daily & Weekly Timesheets.

Supervisor

- Pave Rite, Inc. (May 2011- November 2012)

Responsible for overseeing job production, Operating paving & other heavy equipment. Assisting the owner with various projects.

Asphalt Foreman

- D.A.B. Constructors, Inc. (August 2005- August 2010)

Responsible for a 12 man crew, Daily & Weekly Timesheets, Communicated with local & State Inspectors, The oversight of daily job production, Ability to operate various types of paving and off road equipment, Set up of trucks, and job layout.

Operator

Rinker Materials (May 2005- July 2005)

- Responsible for loading trucks, managing stock piles, also worked on the conveyor.

Asphalt Foreman

- Cheyenne Asphalt (June 2004- January 2005)

Run a 5 man Lee boy crew, specialized in small parking lots, subdivisions, driveways, Seal Coating and Striping. Responsible for setting up trucks, and coordinating all job duties.

Assistant Job Supervisor

- PC Russell Land Clearing & Excavation January 2004- June 2004)

Responsible for daily job operations, trucking, job layouts, operating various pieces of equipment, and loading of trucks on the job site.

Asphalt Foreman

- Grubbs Construction Company (March 1999- June 2004)

Responsible for a crew of 9 employees, daily Timesheets, Communications with Local & State Inspectors, The oversight of daily job production, Ability to operate Rollers, Cat, Barber Green, and Road Tec Pavers and broom tractor.

Asphalt Foreman

- Couch Construction, L.P. (June 1996- March 1999)

Oversight of daily operations, various counts of equipment training, and updated in FDOT policy revisions & procedures.

Asphalt Laborer/ Foreman

- Overstreet Paving Company (April 1984- 1996)

Screed operator and laborer, starting position was rapidly advanced to trainer and later promoted to foreman, Duties included hiring and training employees, skills obtained in the use of multiple pavers (i.e. lee boy and Cedar Rapids.)

Asphalt Foreman

- R.E. Purcell (April 1980- April 1984)

Responsible for a crew of 12 employees, the oversight of daily job production, learned how to run a Blow Knox paver, loader, and other equipment.

ACTIVITES/ INTEREST

Boating, Hunting, and Motorcycles.

REFERENCES AVAILABLE UPON REQUEST

Resume for
Daniel R. Goodwin Jr.
President, Senior Project Manager

EXPERIENCE

Daniel has over 37 years of experience in road construction, sitework, and utilities. He has progressed through various foreman and supervisory positions to his present positions of President and Senior Project Manager.

PROJECT EXPERIENCE Some of Daniel's Projects include:

- Olympia Rd and Skyview Cir Resurfacing and partial reconstruction
- Shoal Line Resurfacing Project
- Various Hernando County MSBU Roadway Projects Areas A,B,C,E,F,G,H,I
- Croom Road Paving Project
- Buczak Culvert Replacement
- SW 95th St Ocala
- Lake Lindsey Road Widening 1,2 and 3
- Flicker Road
- Sunshine Grove Road Widening
- South Brooksville Vision Area
- CR550 Road Widening Project
- Nature Coast Commons- Complete Site Development
- Lake Jovita- Complete Site Development
- Hernando County- 491
- Deerfield Road Widening-Paving
- DOT Brooksville Office- Paving, Grading & Drainage
- DOT- Multiple Turn lanes
- Lake Hancock
- Southern Hills 3
- Florida Department of Transportation Project 97160-3305 & 3323 Polk Co. Parkway Toll Plazas
- Florida Department of Transportation Project 16320-3439 I-4 Dual Rest Areas Polk Co.
- Florida Department of Transportation Project 32610-3432 SR 93 & I-75 Dual Rest Areas Marion Co.
- Eckerd Drug Store #2232R, Spring Hill, Florida
- Eckerd Drug Store #2393R, Tampa, Florida
- Eckerd Drug Store #2581R, Brandon, Florida
- St. Scholastica Church, Lecanto, Florida
- Notre Dame Interparochial School, Spring Hill, Florida
- Airport Subregional Water Waste Treatment Plant, Brooksville, Florida

WORK EXPERIENCE

June 1985-Present

Goodwin Bros. Construction, Inc.

- President/Senior Project Manager Brooksville, FL
- Superintendent over job sites

TRENCH SAFETY ACT COMPLIANCE FORM

1. The Vendor/Contractor acknowledges the existence of the Florida Trench Safety Act at §553.60 through 553.64, Florida Statutes (current version) (hereinafter called the "Act") and the requirements established herein.
2. The Vendor/Contractor further acknowledges that the Act stabled the Federal excavation safety standards set forth at 29 CFR Part 1926, Subpart P as the Interim State standard applicable to this project.
3. The Vendor/Contractor will comply with all applicable trench safety standards, during all phases of the work, if awarded the Contract, and will ensure that all subcontractors will also comply with the Act.
4. The Vendor/Contractor will consider the geotechnical information available from the County, from its own sources and all other relevant information in its design of the trench safety system it will employ on the subject project. The Vendor/Contractor acknowledges that the County is not obligated to provide such information, that Vendor/Contractor is not to rely solely on such information if provided, and that Vendor/Contractor is solely responsible for the selection of the data on which he relies in designing said safety system, as well as for the system itself.
5. The Vendor/Contractor acknowledges that included in the total price in the Bid Form are costs for complying with the Florida Trench Safety Act, which is in effect as of October 1, 1990. The undersigned further identifies the costs to be \$ 1.00 per lineal foot.
6. The amount in Item 5 herein includes the trench safety compliance methods and the units of each safety measure. The unit costs and the unit prices are shown solely for the purpose of compliance with the procedural requirements of the Act.

Trench Safety Compliance Method	Unit (LF, SY)	Quantity	Unit Cost	Extended Cost
A. <u>Benching/Ladders</u>	<u>1810 LF</u>		\$ <u>1.00</u>	\$ <u>1,810.00</u>
B. _____			\$ _____	\$ _____
C. _____			\$ _____	\$ _____
D. _____			\$ _____	\$ _____
TOTAL:				<u>1,810.00</u>

Use additional blank sheets to further itemize if more room is required.

7. Acceptance of the bid to which this certification and disclosure applies in no way represents that the County or its representatives have evaluated or determined that the above costs are adequate to comply with the applicable trench safety requirements, nor does it in anyway relieve the undersigned of his sole responsibility for complying all applicable safety requirements.

Company: Goodwin Brothers Construction Inc.

By: [Signature] April 10 2023
 Authorized Signature Date

This document should be completed and returned with your submittal.

CORPORATE AFFIDAVIT

(To be filled in and executed if the Vendor/Contractor is a Corporation)

STATE OF FLORIDA]

COUNTY OF HERNANDO]

Micheal Goodwin being duly sworn, deposes and says that he is secretary of Goodwin Brothers Construction Inc, a corporation organized and existing under and by virtues of the laws of the State of Florida, and having its principal office at:

14341 Ponce De Leon Blvd, Brooksville, Florida 34601 (Address)

Affiant further says that he is familiar with the records, minute books and bylaws of Goodwin Bros Construction, Inc. (Name of Corporation) of the corporation, is duly authorized to sign Secretary (Title)

the Bid for Dr. Dennis Wilfong Center For Success/Infrastructure for said corporation by virtues of:

(State whether a provision of bylaws or a Resolution of the Board of Directors. If by Resolution, give date of adoption).



Affiant

Sworn to before me this 10 day of April, 2023.



Notary Public

This document should be completed and returned with your submittal.

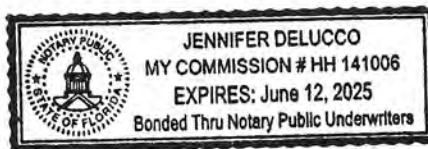

BID BOND

Any singular reference to Vendor/Contractor, Surety, Owner, or other party shall be considered plural where applicable.

VENDOR/CONTRACTOR (Name and Address):

Goodwin Bros. Construction, Inc.
P.O. Box 1689 - Brooksville, FL 34605

SURETY (Name and Address of Principal Place of Business):

Berkley Insurance Company
475 Steamboat Road - Greenwich, CT 06830

OWNER:

BOARD OF COUNTY COMMISSIONERS, HERNANDO COUNTY, FLORIDA
15470 Flight Path Drive
Brooksville, Florida 34604

BID

Project:
23-CG0023/JG – DR. DENNIS WILFONG CENTER FOR SUCCESS/INFRASTRUCTURE
BROOKSVILLE, FLORIDA

BOND

Bond Number: Bid Bond
Date (Not later than bid due date): February 22nd, 2023
Penal sum Five Percent of Amount Bid 5% of Amount Bid
(Words) (Figures)

Surety and Vendor/Contractor, intending to be legally bound hereby, subject to the terms printed on the reverse side hereof, do each cause this Bid Bond to be duly executed on its behalf by its authorized officer, agent, or representative.

VENDOR/CONTRACTOR

SURETY

Goodwin Bros. Construction, Inc. (Seal)
Vendor/Contractor's Name and Corporate Seal

Berkley Insurance Company (Seal)
Surety's Name and Corporate Seal

By: [Signature] President
Signature and Title

By: [Signature] Kevin R. Wojtowicz
Signature and Title Attorney-in-Fact & FL Licensed Agent
(Attach Power of Attorney)

Attest: [Signature] ESTIMATOR
Signature and Title

Attest: [Signature] Margaret A. Schulz, CSR
Signature and Title

Note: Above addresses are to be used for giving required notice.

- 1. Vendor/Contractor and Surety, jointly and severally, bind themselves, their heirs, executors, administrators, successors and assigns to pay to Owner upon default of Vendor/Contractor

POWER OF ATTORNEY
BERKLEY INSURANCE COMPANY
WILMINGTON, DELAWARE

KNOW ALL MEN BY THESE PRESENTS, that BERKLEY INSURANCE COMPANY (the "Company"), a corporation duly organized and existing under the laws of the State of Delaware, having its principal office in Greenwich, CT, has made, constituted and appointed, and does by these presents make, constitute and appoint: Kevin R. Wojtowicz or John R. Neu of Acrisure, LLC dba Nielson, Wojtowicz, Neu & Associates of St. Petersburg, FL its true and lawful Attorney-in-Fact, to sign its name as surety only as delineated below and to execute, seal, acknowledge and deliver any and all bonds and undertakings, with the exception of Financial Guaranty Insurance, providing that no single obligation shall exceed One Hundred Million and 00/100 U.S. Dollars (U.S.\$100,000,000.00), to the same extent as if such bonds had been duly executed and acknowledged by the regularly elected officers of the Company at its principal office in their own proper persons.

This Power of Attorney shall be construed and enforced in accordance with, and governed by, the laws of the State of Delaware, without giving effect to the principles of conflicts of laws thereof. This Power of Attorney is granted pursuant to the following resolutions which were duly and validly adopted at a meeting of the Board of Directors of the Company held on January 25, 2010:

RESOLVED, that, with respect to the Surety business written by Berkley Surety, the Chairman of the Board, Chief Executive Officer, President or any Vice President of the Company, in conjunction with the Secretary or any Assistant Secretary are hereby authorized to execute powers of attorney authorizing and qualifying the attorney-in-fact named therein to execute bonds, undertakings, recognizances, or other suretyship obligations on behalf of the Company, and to affix the corporate seal of the Company to powers of attorney executed pursuant hereto; and said officers may remove any such attorney-in-fact and revoke any power of attorney previously granted; and further

RESOLVED, that such power of attorney limits the acts of those named therein to the bonds, undertakings, recognizances, or other suretyship obligations specifically named therein, and they have no authority to bind the Company except in the manner and to the extent therein stated; and further

RESOLVED, that such power of attorney revokes all previous powers issued on behalf of the attorney-in-fact named; and further

RESOLVED, that the signature of any authorized officer and the seal of the Company may be affixed by facsimile to any power of attorney or certification thereof authorizing the execution and delivery of any bond, undertaking, recognizance, or other suretyship obligation of the Company; and such signature and seal when so used shall have the same force and effect as though manually affixed. The Company may continue to use for the purposes herein stated the facsimile signature of any person or persons who shall have been such officer or officers of the Company, notwithstanding the fact that they may have ceased to be such at the time when such instruments shall be issued.

IN WITNESS WHEREOF, the Company has caused these presents to be signed and attested by its appropriate officers and its corporate seal hereunto affixed this 19th day of May, 2021.



Attest:
By Ira S. Lederman
Executive Vice President & Secretary

Berkley Insurance Company
By Jeffrey M. Hafter
Senior Vice President

STATE OF CONNECTICUT)
) ss:
COUNTY OF FAIRFIELD)

Sworn to before me, a Notary Public in the State of Connecticut, this 19th day of May, 2021, by Ira S. Lederman and Jeffrey M. Hafter who are sworn to me to be the Executive Vice President and Secretary, and the Senior Vice President, respectively, of Berkley Insurance Company.

MARIA C RUNDBAKEN
NOTARY PUBLIC
CONNECTICUT
MY COMMISSION EXPIRES
APRIL 30, 2024

Maria C. Rundbaken
Notary Public, State of Connecticut

CERTIFICATE

I, the undersigned, Assistant Secretary of BERKLEY INSURANCE COMPANY, DO HEREBY CERTIFY that the foregoing is a true, correct and complete copy of the original Power of Attorney; that said Power of Attorney has not been revoked or rescinded and that the authority of the Attorney-in-Fact set forth therein, who executed the bond or undertaking to which this Power of Attorney is attached, is in full force and effect as of this date.



under my hand and seal of the Company, this 22nd day of February, 2023.

Vincent P. Forte

the penal sum set forth on the face of this bond. Payment of the penal sum is the extent of Surety's liability.

2. Default of Vendor/Contractor shall occur upon the failure of Vendor/Contractor to deliver within the time required by the bid documents (or any extension thereof agreed to in writing by Owner) the executed Agreement required by the bid documents and any performance and payment bonds required by the Bid Documents.
3. This obligation shall be null and void if:
 - 3.1. Owner accepts Vendor/Contractor's bid and Vendor/Contractor delivers within the time required by the bid documents (or any extension thereof agreed to in writing by Owner) the executed Agreement required by the bid documents and any performance and payment bonds required by the bid documents, or
 - 3.2. All Bids are rejected by Owner, or
 - 3.3. Owner fails to issue a Notice of Award to Vendor/Contractor within the time specified in the bid documents (or any extension thereof agreed to in writing by Vendor/Contractor and, if applicable, consented to by Surety when required by Paragraph 5 hereof).
4. Payment under this bond will be due and payable upon default by Vendor/Contractor and within thirty (30) calendar days after receipt by Vendor/Contractor and Surety of written notice of default from Owner, which notice will be given with reasonable promptness, identifying this bond and the project and including a statement of the amount due.
5. Surety waives notice of any and all defenses based on or arising out of any time extension to issue Notice of Award agreed to in writing by Owner and Vendor/Contractor, provided that the total time for issuing Notice of Award including extensions shall not in the aggregate exceed one hundred twenty (120) days from bid due date without Surety's written consent.
6. No suit or action shall be commenced under this bond prior to thirty (30) calendar days after the notice of default required in Paragraph 4 above is received by Vendor/Contractor and Surety and in no case later than one (1) year after bid due date.
7. Any suit or action under this bond shall be commenced only in a court of competent jurisdiction located in the state in which the project is located.
8. Notices required hereunder shall be in writing and sent to Vendor/Contractor and Surety at their respective addresses shown on the face of this bond. Such notices may be sent by personal delivery, commercial courier, or by United States Registered or Certified Mail, return receipt requested, postage pre-paid, and shall be deemed to be effective upon receipt by the party concerned.
9. Surety shall cause to be attached to this Bond a current and effective Power of Attorney evidencing the authority of the officer, agent, or representative who executed this bond on behalf of Surety to execute, seal, and deliver such bond and bind the Surety thereby.
10. This bond is intended to conform to all applicable statutory requirements. Any applicable requirement of any applicable statute that has been omitted from this bond shall be deemed to be included herein as if set forth at length. If any provision of this bond conflicts with any

applicable statute, then the provision of said statute shall govern and the remainder of this bond that is not in conflict therewith shall continue in full force and effect.

11. The term "bid" as used herein includes a bid, offer, or proposal as applicable.

This document should be completed and returned with your submittal.

HERNANDO COUNTY EMPLOYMENT DISCLOSURE CERTIFICATION STATEMENT

4/10/2023
(date)

Hernando County
Purchasing and Contracts Department
15470 Flight Path Drive
Brooksville, FL 34604

The undersigned certifies that to the best of his/her knowledge:

Is any officer, partner, director, proprietor, associate or member of the business entity a former employee of Hernando County within the last two (2) years? No Yes

Is any officer, partner, director, proprietor, associate or member of the business entity a relative or member of the household of a current Hernando County employee that had or will have any involvement with this procurement or contract authorization?

No Yes

If the answer to either of the above questions is "Yes", complete the "Relatives and Former Hernando County Employees - Roles and Signatures" table (Part A and/or Part B, as applicable).

Bidder:

ESTIMATOR@GOODWINBROSINC.COM
(Email address)

(Signature required)

Daniel Goodwin Jr.
(Print name)

Daniel Goodwin Jr.
(Print title)

14341 RINGF DELEON BLD
(Address)
Brooksville, FL 34601

352-796-0149
(Phone)

352-544-1084
(Fax)

59-2827531
(Federal Taxpayer ID Number)

Relatives and Former Hernando County Employees – Roles and Signatures

Part A: Employees that left Hernando County in the last two years.

Employee Name/Signature	Job Performed for Hernando County	Current Role with Business Entity	Date Left Hernando County
Name: _____ Sign: _____ • Involved with this procurement on behalf of Hernando County? No <input type="checkbox"/> Yes <input type="checkbox"/> • Involved with proposal development for this procurement? No <input type="checkbox"/> Yes <input type="checkbox"/>	N/A		
Name: _____ Sign: _____ • Involved with this procurement on behalf of Hernando County? No <input type="checkbox"/> Yes <input type="checkbox"/> • Involved with proposal development for this procurement? No <input type="checkbox"/> Yes <input type="checkbox"/>			
Name: _____ Sign: _____ • Involved with this procurement on behalf of Hernando County? No <input type="checkbox"/> Yes <input type="checkbox"/> • Involved with proposal development for this procurement? No <input type="checkbox"/> Yes <input type="checkbox"/>			

Part B: Identify officers, partners, directors, proprietors, associates or members of the business entity that are relatives or members of the household of Hernando County employees currently working for Hernando County, if Hernando County employee had or will have any involvement with this procurement of contract.

Firm Officer, Partner, Director, Proprietor, Associate or Member Name	Name and Relationship of Relative or Member of Household Employed at Hernando County	Role at Hernando County	Hernando County employee's Role with this Procurement
N/A			

(Make copies of this form as needed to list additional employees.)

This document should be completed and returned with your submittal.

Convicted or Discriminatory Vendor List Statement

Those who have been placed on the convicted vendor list following a conviction for a public entity crime or on the discriminatory vendor list may not submit a bid on the contract to provide any goods or services to a public entity, may not submit a bid on a contract with a public entity for construction or repair of a public building or public work, may not submit bids on leases of real property to a public entity, may not be awarded or perform work as a contractor, supplier, subcontractor, or consultant under a contract with a public entity, and may not transact business with any public entity in excess of \$25,000.00 for a period of 36 months from the date of being placed on the convicted vendor list or on the discriminatory vendor list.

CERTIFICATION REGARDING DEBARMENT, SUSPENSION, INELIGIBILITY AND VOLUNTARY EXCLUSION

It is certified that neither the below identified firm nor its principals are presently suspended, proposed for debarment, declared ineligible, or voluntarily excluded from participation in this transaction by any federal department or agency.

Name of Company/Firm: Goodwin Brothers Construction Inc.

By:  Date: 4/7/2023
Authorized Signature

Title: President

Instructions for Certification

1. Certifies the company/firm are not presently debarred, suspended, proposed for debarment, declared ineligible, or voluntarily excluded from covered transactions by the federal department or agency;
2. have not within a five-year period preceding this proposal been convicted of or had a civil judgment rendered against them for fraud or a criminal offense in connection with obtaining, attempting to obtain, or performing a public (federal, state or local) transaction or contract under public transaction; violation of federal or state antitrust statutes or commission of embezzlement, theft, forgery, bribery, falsification or destruction of records, making false statements, or receiving stolen property;
3. are not presently indicated or otherwise criminally or civilly charged by a governmental entity (federal, state or local) with commission of any offenses enumerated in this document; and
4. have not within five-year period preceding this Agreement had one or more public transactions (federal, state or local) terminated for cause or default.

If the above is unable to certify to any of the statements in this certification, then the company/firm shall attach an explanation to this agreement.

DISCLOSURE OF LOBBYING ACTIVITIES

OMB Control Number: 4040-0013

Expiration Date: 2/28/2025

Complete this form to disclose lobbying activities pursuant to 31 U.S.C. 1352

Review Public Burden Disclosure Statement

1. * Type of Federal Action: <input type="radio"/> a. contract <input checked="" type="radio"/> b. grant <input type="radio"/> c. cooperative agreement <input type="radio"/> d. loan <input type="radio"/> e. loan guarantee <input type="radio"/> f. loan insurance	2. * Status of Federal Action: <input type="radio"/> a. bid/offer/application <input checked="" type="radio"/> b. initial award <input type="radio"/> c. post-award	3. * Report Type: <input checked="" type="radio"/> a. initial filing <input type="radio"/> b. material change For Material Change Only: year <input type="text"/> quarter <input type="text"/> date of last report <input type="text"/>
4. Name and Address of Reporting Entity: <input checked="" type="radio"/> Prime <input type="radio"/> SubAwardee Tier if known: <input type="text"/> * Name <input type="text" value="Goodwin Brothers Construction Inc."/> * Street 1 <input type="text" value="14341 Ponce De Leon Blvd"/> Street 2 <input type="text"/> * City <input type="text" value="Brooksville"/> State <input type="text" value="Florida"/> Zip <input type="text" value="34601"/> Congressional District, if known: <input type="text"/>		
5. If Reporting Entity in No.4 is Subawardee, Enter Name and Address of Prime: * Name <input type="text" value="No Lobbying activity to report"/> * Street 1 <input type="text"/> Street 2 <input type="text"/> * City <input type="text"/> State <input type="text"/> Zip <input type="text"/> Congressional District, if known: <input type="text"/>		
6. * Federal Department/Agency: <input type="text"/>	7. * Federal Program Name/Description: <input type="text"/> CFDA Number, if applicable: <input type="text"/>	
8. Federal Action Number, if known: <input type="text"/>	9. Award Amount, if known: \$ <input type="text"/>	
10. a. Name and Address of Lobbying Registrant: Prefix <input type="text"/> * First Name <input type="text"/> Middle Name <input type="text"/> * Last Name <input type="text"/> Suffix <input type="text"/> * Street 1 <input type="text"/> Street 2 <input type="text"/> * City <input type="text"/> State <input type="text"/> Zip <input type="text"/>		
b. Individual Performing Services (including address if different from No. 10a) Prefix <input type="text"/> * First Name <input type="text"/> Middle Name <input type="text"/> * Last Name <input type="text"/> Suffix <input type="text"/> * Street 1 <input type="text"/> Street 2 <input type="text"/> * City <input type="text"/> State <input type="text"/> Zip <input type="text"/>		
11. Information requested through this form is authorized by title 31 U.S.C. section 1352. This disclosure of lobbying activities is a material representation of fact upon which reliance was placed by the tier above when the transaction was made or entered into. This disclosure is required pursuant to 31 U.S.C. 1352. This information will be reported to the Congress semi-annually and will be available for public inspection. Any person who fails to file the required disclosure shall be subject to a civil penalty of not less than \$10,000 and not more than \$100,000 for each such failure. * Signature: <input type="text" value="Daniel Ray Jr."/> * Name: Prefix <input type="text" value="Mr"/> * First Name <input type="text" value="Daniel"/> Middle Name <input type="text" value="RAY"/> * Last Name <input type="text" value="Goodwin"/> Suffix <input type="text" value="Jr."/> Title: <input type="text" value="President"/> Telephone No.: <input type="text" value="352-796-0149"/> Date: <input type="text" value="4/7/2023"/>		
Federal Use Only:		STANDARD FORM LLL (REV. 7/1997) Authorized for Local Reproduction

CERTIFICATION FOR DISCLOSURE OF LOBBYING ACTIVITIES

The prospective participant certifies, by signing this certification, that to the best of his or her knowledge and belief:

(1) No federal appropriated funds have been paid or will be paid, by or on behalf of the undersigned, to any person for influencing or attempting to influence an officer or employee of any federal agency, a Member of Congress, an officer or employee of Congress, or an employee of a Member of Congress in connection with the awarding of any federal contract, the making of any federal grant, the making of any federal loan, the entering into of any cooperative agreement, and the extension, continuation, renewal, amendment or modification of any federal contract, grant, loan, or cooperative agreement.

(2) If any funds other than federal appropriated funds have been paid or will be paid to any person for influencing or attempting to influence an officer or employee of any federal agency, a Member of Congress, an officer or employee of Congress, or an employee of a Member of Congress in connection with this federal contract, grant, loan, or cooperative agreement, the undersigned shall complete and submit Standard Form-LLL, "Disclosure of Lobbying Activities", in accordance with its instructions. (Standard Form-LLL can be obtained from the Hernando County Purchasing & Contracts Office.)

This certification is a material representation of fact upon which reliance was placed when this transaction was made or entered into. Submission of this certification is a prerequisite for making or entering into this transaction imposed by Section 1352, Title 31, U.S. Code. Any person who fails to file the required certification shall be subject to a civil penalty of not less than \$10,000 and not more than \$100,000 for each such failure.

The prospective participant also agrees by submitting his or her proposal that he or she shall require that the language of this certification be included in all lower tier subcontracts, which exceed \$100,000 and that all such subrecipients shall certify and disclose accordingly.

Name of Company/Firm: Goodwin Brothers Construction Inc,

By:  Date: 4/7/2023
Authorized Signature

Title: President

GOOD FAITH EFFORTS

The County is committed to supplier diversity in the performance of all contracts associated with Federal and State funding projects. The County requires the Bidder/Contractor to make good faith efforts to encourage the participation of minority owned and woman owned and small business enterprises in accordance with applicable laws.

The Bidder/Contractor is required to submit documentation upon request to the County to reflect the affirmative action steps taken to utilize minority owned and women owned and small business enterprises in the work and the intended use of these companies in the work.

The Bidder/Contractor is required to include in their bid documentation that the Bidder has carried out these affirmative steps for Disadvantaged, Minority and Disabled Veterans Business Enterprise participation as follows:

- 1) Included qualified Disadvantaged, Minority and Disabled Veterans Business Enterprise on solicitation lists.
- 2) Solicited Disadvantaged, Minority and Disabled Veterans Business Enterprise whenever they are potential sources.
- 3) Divided total requirements, when economically feasible, into small tasks or quantities to permit maximum participation by Disadvantaged, Minority and Disabled Veterans Business Enterprise.
- 4) Where feasible, established delivery schedules which will encourage participation by Disadvantaged, Minority and Disabled Veterans Business Enterprise.

The following websites are provided to assist Bidder/Contractor with Affirmative steps.

i. U.S. Small Business Administration

<http://dsbs.sba.gov/dsbs/>

ii. Florida Department of Transportation, Equal Opportunity Office

<http://www.dot.state.fl.us/equalopportunityoffice/>

iii. <http://www3b.dot.state.fl.us/EqualOpportunityOfficeBusinessDirectory/>

iv. Florida Office of Supplier Diversity

https://www.dms.myflorida.com/agency_administration/office_of_supplier_diversity_osd

Bidder/Contractor will be responsible for participating in these affirmative steps and providing documentation to that effect. County will be responsible to verify/certify it has obtained and reviewed documentation from the apparent lowest, responsive, responsible bidder demonstrating a good faith effort to facilitate Disadvantaged, Minority and Disabled Veterans Business Enterprise participation in this contract.

By signing my name below, I certify that I have read the above information. My signature also certifies my understanding and agreement with the above terms and conditions.



Authorized Signature

4/7/2023

Date

Daniel Goodwin Jr President
Name (Printed)

Disadvantaged Business Enterprise (DBE) Affirmation Statement

Prime Contractor/Prime Consultant: Goodwin Brothers Construction Inc,

Telephone Number: 352-796-0149

Address: 14341 Ponce De Leon Blvd, Brooksville, Florida 34601

I hereby certify that the above stated contractor/consultant is a (select one):

DBE

Non-DBE

Subcontractor Services List

Please list all subcontractors for services:

• Company Name: CBS Underground

Telephone Number: 352-351-4605

Address: P.O. Box 930 Ocala FL 34478

The above company named is a (select one):

DBE

Non-DBE

• CompanyName: AKCA, Inc

Telephone Number: 813-752-4471

Address: 4603 Reece Rd Plant City, FL 33566

The above company named is a (select one):

DBE

Non-DBE

• Company Name: Coastal Engineering

Telephone Number: 352-796-9423

Address: 966 Candlelight Blvd Brooksville, FL 34601

The above company named is a (select one):

DBE

Non-DBE

• Company Name: J&J Sod

Telephone Number: 352-586-9048

Address: PO Box 1032 Inverness, FL 34451

The above company named is a (select one):

DBE

Non-DBE

• Company Name: Road Safe Traffic Systems

Telephone Number: 813-740-0468

Address: 1861 Massaro Blvd Tampa, FL 33619

The above company named is a (select one):

DBE

Non-DBE

FLORIDA CONFLICT OF INTEREST CERTIFICATION

4/7/2023

(date)

Hernando County Purchasing and Contracts
15470 Flight Path Drive
Brooksville, FL 34604

The undersigned certifies that to the best of his/her knowledge: **(check only one)**

- There is no officer or employee of Hernando County, FL who has, or whose relative has, a substantial interest in any contract resulting from this request.

- The names of any and all public officers or employees of Hernando County, FL who have, or whose relative has, a substantial interest in any contract resulting from this request, and the nature of the substantial interest, are included below or as an attachment to this certification.

Bidder:

estimator@goodwinbrosinc.com

(Email address)

14341 Ponce De Leon Blvd, Brooksville, Florida 34601

(Address)

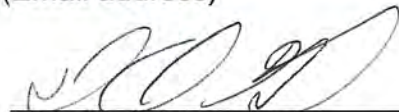

(Signature required)

352-796-0149

(Phone)

Daniel Goodwin Jr

(Print name)

352-544-1084

(Fax)

President

(Print title)

59-2827531

(Federal Taxpayer ID Number)

Representation Regarding Felony Convictions or Tax Delinquent Status

All applicants must complete the paragraph (1) of this representation, and all corporate applicants also must complete paragraphs (2) and (3) of this representation.

- (1) Applicant, Goodwin Brothers Construction Inc, _____, [insert applicant name] is is not _____ (check one) an entity that has filed articles of incorporation in one of the fifty states, the District of Columbia, or the various territories of the United States including American Samoa, Federated States of Micronesia, Guam, Midway Islands, Northern Mariana Islands, Puerto Rico, Republic of Palau, Republic of the Marshall Islands, U.S. Virgin Islands. (Note that this includes both for-profit and non-profit organizations.)

For those applicants who indicate above that they are a corporation, the applicant must complete paragraphs (2) and (3) of the representation.

- (2) Applicant, Goodwin Brothers Construction Inc, _____, [insert corporation name] has _____ has not (check one) been convicted of a felony criminal violation under Federal or State law (check as applicable) in the 24 months preceding the date of application. Applicant has _____ has not (check one) had any officer or agent of Applicant convicted of a felony criminal violation for actions taken on behalf of Applicant under Federal or State law in the 24 months preceding the date of signature.

- (3) Applicant, Goodwin Brothers Construction Inc, _____, [insert corporation name] has _____ does not have (check one) any unpaid Federal tax liability that has been assessed, for which all judicial and administrative remedies have been exhausted or have lapsed, and that is not being paid in a timely manner pursuant to an agreement with the authority responsible for collecting the tax liability.

Providing the requested information is voluntary. However, failure to furnish the requested information will make the applicant ineligible to enter into a contract, memorandum of understanding, grant, loan, loan guarantee, or cooperative agreement with USDA.

APPLICANT'S SIGNATURE (BY) 	TITLE/RELATIONSHIP OF THE INDIVIDUAL IF SIGNING IN A REPRESENTATIVE CAPACITY President	DATE SIGNED (MM-DD-YYYY) 11-10-2023
--	--	---

The U.S. Department of Transportation (USDOT) prohibits discrimination in all of its programs and activities on the basis of race, color, national origin, age, disability, and where applicable, sex, marital status, familial status, parental status, religion, sexual orientation, political beliefs, genetic information, reprisal, or because all or part of an individual's income is derived from any public assistance program. (Not all prohibited bases apply to all programs.) Persons with disabilities who require alternative means for communication of program information (Braille, large print, audiotape, etc.) should contact Disability Resource Center, U.S. Department of Transportation, 1200 New Jersey Ave, SE, W56-403, Washington, DC 20590, United States, drc@dot.gov USDOT is an equal opportunity provider and employer.

ADDENDA CONFIRMATION

✔ Addendum #1

Confirmed Apr 4, 2023 10:18 AM by Tom Charlow

✔ Addendum #2

Confirmed Apr 4, 2023 10:18 AM by Tom Charlow

✔ Addendum #3

Confirmed Apr 4, 2023 10:18 AM by Tom Charlow

ADDENDUM NO. ONE (1)

TO
THE CONTRACT DOCUMENTS
FOR THE

DR. DENNIS WILFONG CENTER FOR SUCCESS/INFRASTRUCTURE - REBID

IN
HERNANDO COUNTY, FLORIDA
SOLICITATION NO. 23-CG0215/JG

BID DATE: APRIL 10, 2023

NOTICE

BIDDERS ARE REQUIRED TO ACKNOWLEDGE RECEIPT OF THIS ADDENDUM BY SIGNATURE AT THE BOTTOM OF THIS ADDENDUM IN THE SPACES PROVIDED AND RETURNED AT THE TIME OF THE BID DATE.

TO ALL PLAN HOLDERS:

The following changes, additions and/or deletions are hereby made a part of the Contract Documents for the **DR. DENNIS WILFONG CENTER FOR SUCCESS/INFRASTRUCTURE - REBID**, located in Hernando County, as fully and completely as if the same were fully set forth therein:

A. ADDITION TO GENERAL CONDITIONS SECTION, PARAGRAPH

CLARIFICATIONS

1. **Question:** On this electronic bid on the Portal, is it possible to submit a Bid and then Re-submit if our price changes, so long as Bid is received by you before the Bid Deadline?

Answer: This information is provided in OpenGov by clicking on the blue assistant circle located on the bottom right-hand corner of the screen in OpenGov. Information regarding bid submissions and re-submitting a bid submission is available in this OpenGov article: <https://help.procurement.opengov.com/en/articles/5681151-how-to-edit-or-withdraw-your-proposal-after-it-s-been-submitted>.

2. **Question:** For the Lift Station, - Plan Sheet C-14 Legend Note 6 states “ (furnish) Generator per Plans & Specs. But we do not find information/size/brand in the Plans. - Spec section 11.14 states : “ Vendor required to provide electrical design for the pump station that includes sizing of the generator” As a Site Contractor, we are not in the business of Electrical design nor sizing of generators. a. We can only Bid this project per the design/Plans/specs that are furnished by the project owner. b. Please confirm that Bidders will not be responsible for any design at the Pump Station. c. For purposes of getting apples-to-apples pricing, can Engineer furnish some basic guidelines on the generator so the Bidders will be bidding the same basic generator.

Answer: The Contractor shall provide a generator capable of meeting the attached HCUD specifications. Any design fees for generator sizing shall be included in the bid price.

3. **Question:** Will the Lift Station be powered strictly by a generator or will there be permanent Electric power to the Lift Station ? ___ a. Will power be furnished/pulled to the Lift Station location ? ___ b. Will Contractors be required to bring in Power ? c. If Contractor will be bringing in power, from what location/distance , and what size Feed is needed ?

Answer: Pump station will be powered by connection to the Duke Energy grid. Contractor shall coordinate and include connection fees for power company connection. Connection will need to be coordinated with Duke Energy.

4. **Question:** Plan sheet C -14 note states : “ ** Specs are for Flygt ..pump. Alternate Systems may be submitted for ...approval” a. Our understanding of the Note is that all Bids are to include *Flygt pumps in those Bids, with the successful Contractor submitting Alternate Pumps/Prices after the Contract is awarded . b. Please confirm our understanding.

Answer: Bids should include a pump meeting the flow/head characteristics shown in the plans and listed as an approved manufacture by HCUD.

5. **Question:** Plan sheet C -14 note 12 states “Site Lighting (at Lift Station) , per Plans and Specs”, but do not find this information in plans or specs.

Answer: Model/Type or Equivalent: LIGHT - LSBT1C8T3F1WH-BK PC6
POLE - SSP 20 4 11 BK T238

6. **Question:** Will the Lift Station require a Flow Meter? a. If so, please furnish a spec/brand for this Meter.

Answer: No sewer meter is proposed at the pump station.

7. **Question:** At the Pre-Bid, there was brief mention of a future Monument Sign. Is it a correct assumption that we do not include anything for that Sign until more requirements are known?

Answer: No monument sign is included in this bid package.

8. **Question:** Please confirm Limits of Clearing . At the Pre-Bid Walk-through , it was mentioned that Clearing is limited to *work* areas being developed in this phase. a. Plan sheet C-03, Existing Conditions shows *BOCC* Tract and *HCSD* Tract as “ Do Not Clear” . b. We understand that the above 2 Tracts will need Clearing for the limits of Sidewalk construction, outside the Silt Fence Limits . c. *PHSC* Tract does not have the same note from above , but it is located inside the Silt Fence limits , which *might indicate “No Clearing”. d. Do we include Clear-Cut Clearing from the northern limit of *BOCC* Tract all the way to Spring Hill Drive , for the Lift Station work, or is it more selective Clearing , just for the Access Road and the Lift Station itself ? e. Please clarify questions on Clearing from b , c, and d above .

Answer: The area inside the silt fence on the PHSC and HCSD tract is not to be cleared. Clearing shall be for the improvements located outside the silt fence area.

9. **Question:** Plan Sheet C-05 Grading Plan . Please confirm Grades required at : a. at Access/Stabilized road to Lift Station shows edge Elevations of 67.5'. We understand the note “ Future Elevation 69.5” to apply to a later project. b. *BOCC* Tract and *HCSD* Tract show Finished Floor Elevations for the overall Tracts , which we understand to indicate no Grading or Fill during this project.

Answer: Future finished floor elevations are for permitting and future design purposes. No grading shall be done to bring the sites to their future finished floor elevations with this contract.

10. **Question:** Plan Sheet C -06 shows Sections through the Ponds . a. *Pond A* has a Section A-A, shown on plan Sheet C-09 b. * Existing* Pond, just north of Pond A also has a Section A-A - - What plan Sheet is this section shown on?

Answer: Section B-B is provided on Sheet C-09 and shows the north south cross section of the proposed and existing pond.

11. **Question:** Plan Sheet C -06 shows Chain Link Fence around Pond A. What is specification for the Pond Fence ? a. Does Plan sheet C-15 Detail apply to the Pond also (or just the Lift Station Fence). b. Plans do not show, what is requirement for Gate(s)?

Answer: The chain link fence shown on Sheet C-06 shall meet the requirements of the security fence detail shown on Sheet C-15. A 20' dual swing gate shall be provided in the SE corner of the pond as shown on Sheet C-06.

12. **Question:** Plan Sheet C-08 show work at an Existing Pond with a different pond shape than the Existing Pond shown on Plan sheet C-06 . We do not find this Pond on Plan sheet C-04 Master Plan. Is this an additional / Off Site pond ? a. If so , please furnish information to locate this Pond on a map.

Answer: The pond on Sheet C-08 is a modification to the existing floodplain compensation pond located east of the site on Spring Hill Drive. See the match line on Sheets C-07 and C-08.

13. **Question:** Plan Sheet C-12 has several notes about “ Contractor to locate Water Main ... Relocation of water may be necessary”. a. Our understanding is that we are to include the cost to locate and identify any possible conflicts at those 3 locations. b. Any costs to relocate Conflicting utilities would be addressed later. c. Please confirm our understanding.

Answer: The contractor is to locate the existing water main at the identified approximate locations and confirm if relocation will be required. Cost for relocating shall be included in the bid.

14. **Question:** In the Bid Form, item 14.6 Bidder Acknowledgement states : “ (bidder) Agrees at time of submitting bid that no further examinations, investigations, explorations, tests, studies or data are necessary for determination of its bid” a. Bidders submit Bids to be based solely on the information furnished by the project’s Owner at the time of the Bid and Bidders do not assume responsibility for any discovered conditions encountered during the course of construction. b. Please confirm the above understanding.

Answer: The bidder Acknowledgement statement, in the Vendor Questionnaire section, is to be confirmed if the bidder acknowledges their bid submission is based on the information supplied in the solicitation and that there are no further examinations, investigations, explorations, tests, studies, or data necessary for the determination of the bid submission for performance of the work at the prices supplied and within the times and in accordance with the other terms and conditions of the bid documents.

15. **Question:** Please clarify Scope of work required for Bid Item 9 Temporary Construction Access

Answer: Temporary construction access shall include the installation of a temporary soil tracking device at the site entrance per the detail provided on Sheet C-21.

BOARD OF COUNTY COMMISSIONERS
HERNANDO COUNTY

Caleb Rosset - State

Acknowledged

for: Toni Brady
Chief Procurement Officer, Hernando County

Issued: March 24, 2023

ADDENDUM NO. TWO (2)

TO
THE CONTRACT DOCUMENTS
FOR THE

DR. DENNIS WILFONG CENTER FOR SUCCESS/INFRASTRUCTURE - REBID

IN
HERNANDO COUNTY, FLORIDA
SOLICITATION NO. 23-CG0215/JG

BID DATE: APRIL 10, 2023

NOTICE

BIDDERS ARE REQUIRED TO ACKNOWLEDGE RECEIPT OF
THIS ADDENDUM BY SIGNATURE AT THE BOTTOM OF
THIS ADDENDUM IN THE SPACES PROVIDED AND
RETURNED AT THE TIME OF THE BID DATE.

TO ALL PLAN HOLDERS:

The following changes, additions and/or deletions are hereby made a part of the Contract Documents for the **DR. DENNIS WILFONG CENTER FOR SUCCESS/INFRASTRUCTURE - REBID**, located in Hernando County, as fully and completely as if the same were fully set forth therein:

A. ADDITION TO GENERAL CONDITIONS SECTION, PARAGRAPH

CLARIFICATIONS

1. **Question:** Plan sheet C-06 shows Retention Pond "A", and a Proposed 6' Chain Link Fence around the pond perimeter. a. Can you furnish a new Bid Item for this 600 Feet of Fence and a (?)_ wide Gate .b. There is a Black Vinyl-coated Fence at the Lift Station, and we understand that fence to part of the Lump Sum Lift Station item, correct ?

Answer: A. Use 10 ft wide gate for pond, no bid item should be needed. B. cost for Lift station fence to be included in lump sum price for Lift Station.

2. **Question:** Can you extend the deadline for RFI/Questions? Pre-Bid was March 5 and Deadline is currently set as Monday March 20. More questions are sure to come up from the Subs/Suppliers as we get closer to the bid on April 10th, which would be 20 days after the RFI Deadline). a. To help get all the questions in, can RFI Deadline be extended to March 27th (which would still be 14 days before the Bid)?

Answer: The deadline cannot be moved.

3. **Question:** Plan Sheet C-15 shows installation Details for an RTU Antenna. a. Are there any Specifications for this very expensive Antenna and associated Panel ?

Answer: See Sheet C-15, Detail 45, Note 4. RTU Antenna is supplied by Data Flow Systems.

4. **Question:** Plan Sheet C-15 shows installation Detail for an Odor Control Unit. a. Are there any Specifications / Models/Brands for this equipment?

Answer: See HCUD Construction Specifications Manual per sheet C-02, Note 1 for Generator requirements.

5. **Question:** Please specify any sound attenuation requirements for the generator enclosure. Please provide sizing requirements if needed for this will vary the price greatly on the generator.

Answer: See HCUD Construction Specifications Manual per sheet C-02, Note 1 for Generator requirements. Per previous response to question 2, the contractor shall provide a generator capable of meeting HCUD specifications and shall include design fees necessary for generator sizing in the bid cost.

6. **Question:** Based on our calculations we do not believe a 100 AMP service is enough to power the lift station. With the 208V 3 Phase each 15 HP motor is 46.2 amps. So $46.2 \times 2 = 92.4 \times 1.25 = 115$ Amps + Odor Control + Receptacle. With the 240V 3 Phase each 15 HP motor is 42 amps. So $42 \times 2 = 84 \times 1.25 = 105$ Amps + Odor Control + Receptacle. Please confirm if service should be upsized.

Answer: Bidders should consider upsizing lift station service to 200 AMP.

BOARD OF COUNTY COMMISSIONERS
HERNANDO COUNTY



for: Toni Brady
Chief Procurement Officer, Hernando County

Acknowledged

Issued: March 24, 2023

ADDENDUM NO. THREE (3)

TO
THE CONTRACT DOCUMENTS
FOR THE

DR. DENNIS WILFONG CENTER FOR SUCCESS/INFRASTRUCTURE - REBID

IN
HERNANDO COUNTY, FLORIDA
SOLICITATION NO. 23-CG0215/JG

BID DATE: APRIL 10, 2023

NOTICE

BIDDERS ARE REQUIRED TO ACKNOWLEDGE RECEIPT OF THIS ADDENDUM BY SIGNATURE AT THE BOTTOM OF THIS ADDENDUM IN THE SPACES PROVIDED AND RETURNED AT THE TIME OF THE BID DATE.

TO ALL PLAN HOLDERS:

The following changes, additions and/or deletions are hereby made a part of the Contract Documents for the **DR. DENNIS WILFONG CENTER FOR SUCCESS/INFRASTRUCTURE - REBID**, located in Hernando County, as fully and completely as if the same were fully set forth therein:

A. ADDITION TO GENERAL CONDITIONS SECTION, PARAGRAPH 22

Addition to General Conditions section, Paragraph 22. E-Verify:

In accordance with section 448.095, F.S., the State of Florida expressly requires the following:

1. Every public employer, contractor, and subcontractor shall register with and use the E-Verify system to verify the work authorization status of all newly hired employees. A public employer, contractor, or subcontractor may not enter into a contract unless each party to the contract registers with and uses the E-Verify system.
2. A private employer shall, after making an offer of employment which has been accepted by a person, verify such person's employment eligibility. A private employer is not required to verify the employment eligibility of a continuing employee hired before January 1, 2021. However, if a person is a contract employee retained by a private employer, the private employer must verify the employee's employment eligibility upon the renewal or extension of his or her contract.

If an entity does not use E-Verify, the entity shall enroll in the E-Verify system prior to hiring any new employee or retaining any contract employee after the effective date of this award.

BOARD OF COUNTY COMMISSIONERS
HERNANDO COUNTY

Alisa Pike

Digitally signed by Alisa Pike
Date: 2023.03.28 15:59:16 -04'00'

Acknowledged

for: Toni Brady
Chief Procurement Officer, Hernando County

Issued: March 28, 2023