



DEPARTMENT OF PURCHASING AND CONTRACTS

15470 FLIGHT PATH DRIVE ♦ BROOKSVILLE, FLORIDA 34604
P 352.754.4020 ♦ F 352.754.4199 ♦ W www.HernandoCounty.us

DATE: October 17, 2022
TO: Jane Gonzalez, Purchasing Agent II
FROM: Josh Martin, Water Distribution Supervisor, Hernando County Utilities Department
SUBJECT: Recommendation for Award Bid No. 22-T00124/JG
Project Name: Purchase of Meter Boxes as Needed

The attached bid received from Core & Main for the above referenced project/solicitation is submitted for your review, evaluation, and award recommendation. In accordance with the Hernando County Ordinance No. 93.16, Section 2-105 (6) and Purchasing and Contracts Department Policies and Procedures Manual, Procedure No. 130F, Paragraph 3. (D), Policy 140I, Paragraph 2(H), please complete items 2 through 6 and return this award recommendation form with your technical evaluation attached, approved by your department director/manager on or by 5:00 p.m. on September 9, 2022.

- 1. Total Contract Bid Price is: \$605,206.00
2. Reference checks are satisfactory: [X] YES [] NO
3. Recommend award as responsive and responsible bidder [X] YES [] NO
4. Request Next Bidder? [] YES [X] NO
5. Provide a statement that addresses the reason(s) for your recommendation or rejection.

Core and Main provided the lowest responsive bid based on the required materials. The bid was for DFW Plastics material. Example meter box item numbers were provided and in the event those numbers no longer existed, they could provide another DFW item that was equal to the example provided.

6. Provide the funding information: Fund 4121 / 4132 Dept 07201 / 07213 Account 5305280

Recommendation Approved By: [Signature] Date: 11/18/22
Department Director/Manager

Enclosure



UTILITIES DEPARTMENT

WATER & WASTEWATER OPERATIONS

15400 WISCON ROAD ♦ BROOKSVILLE, FLORIDA 34601
P 352.754.4490 ♦ F 352.754.4167 ♦ W www.HernandoCounty.us

Memorandum

To: Jane Gonzalez, Purchasing Agent I

Thru: Ricky Leach, Operations Manager 

From: W. Josh Martin, Water Distribution Supervisor 

Date: November 15, 2022

Subject: 22-T00124/JG Purchase of Meter Boxes as Needed

After reviewing the bid documents submitted by the six (6) vendors, Hernando County Utilities Department has determined that two (2) of the bidders did not submit a bid on the materials as requested, thus removed them from consideration. Those bidders are Consolidated Pipe & Supply and Empire Pipe & Supply. The reasons for not considering them are listed below.

1. The solicitation for bid states "For Providing DFW Plastics, Inc. Meter Boxes For The Hernando County Utilities Department". The above vendors submitted Sigma boxes with Nicor lids, not DFW Plastics boxes and lids (see attached).
2. Under the Meter Box and Lid Description – Estimated Annual Quantities, Hernando County Utilities submitted DFW part numbers and at the end of those part numbers it states "or equivalent". The purpose of this language is because specific DFW part numbers were provided and if DFW no longer manufactured that particular item or changed its part number, HCUD wanted the equivalent DFW box and lid to the one in the contract (see attached).
3. Under Technical Specifications (67.3 Polymer Body 67.3.1) it states "The polymer body shall be flared and have a minimum of 3/8" wall thickness." The Sigma boxes that were submitted by the above referenced vendors are not flared boxes, they are straight walled boxes (see attached illustration).

Hernando County Utilities has purchased DFW Plastics meter boxes for several years and we are satisfied with the boxes and manufacturer. We called out these specific boxes in this bid solicitation for this reason.

HCUD is requesting the Purchasing Department proceed with awarding this contract to the lowest responsive bidder (Core and Main) that submitted a bid on DFW Plastics, Inc. meter boxes as advertised.

Responsive Bidders:

Core and Main	\$605,206
Fortiline, Inc.	\$608,182
Ferguson Waterworks	\$621,816
The Avanti Company	\$777,220

If you have any questions or concerns, please let me know.



SOLICITATION - OFFER - AWARD

SOLICITATION NO.: 22-T00124/JG	SOLICITATION TITLE: PURCHASE OF METER BOXES AS NEEDED	DATE ISSUED: JULY 20, 2022	CONTRACT NO.: 22-T00124/JG
ISSUED BY: BOARD OF COUNTY COMMISSIONERS HERNANDO COUNTY, FLORIDA Steve Champion, Chairman John Allocco, Vice Chairman Beth Narverud, Second Vice Chairman Wayne Dukes Jeff Holcomb		SUBMIT BID OFFER TO: HERNANDO COUNTY PURCHASING AND CONTRACTS DEPARTMENT 15470 FLIGHT PATH DRIVE BROOKSVILLE, FL 34604 Toni Brady Chief Procurement Officer	

SOLICITATION

SEALED OFFERS FOR FURNISHING THE SERVICES, SUPPLIES OR EQUIPMENT DESCRIBED HEREIN WILL BE RECEIVED AT THE OFFICE OF PURCHASING AND CONTRACTS DEPARTMENT, VIA HERNANDO COUNTY'S EPROCUREMENT PORTAL AT: <https://secure.procurenow.com/portal/hernandocounty>, **UNTIL 3:00 P.M., LOCAL TIME ON AUGUST 24, 2022.** NO BID OFFERS WILL BE ACCEPTED AFTER THE ABOVE STIPULATED DATE AND TIME. THIS IS AN ADVERTISED SOLICITATION AND THE RESPONDING BIDDERS WILL BE PUBLICLY READ IN THE PURCHASING AND CONTRACTS DEPARTMENT CONFERENCE ROOM, 15470 FLIGHT PATH DRIVE, BROOKSVILLE, FL 34604 AT **3:00 P.M. ON AUGUST 24, 2022.** PURSUANT TO FS 119.071 (Current Edition), SEALED BIDS, PROPOSALS, OR REPLIES RECEIVED BY AN AGENCY PURSUANT TO A COMPETITIVE SOLICITATION ARE EXEMPT FROM INSPECTION UNTIL SUCH TIME AS THE AGENCY PROVIDES NOTICE OF AN INTENDED DECISION OR UNTIL THIRTY (30) DAYS AFTER OPENING THE BIDS, PROPOSALS, OR FINAL REPLIES, WHICHEVER IS EARLIER.

ITEM NO.	DESCRIPTION OF SERVICE/SUPPLIES/EQUIPMENT	QTY	UNIT	UNIT PRICE	TOTAL AMOUNT
1	FOR PROVIDING DFW PLASTICS, INC. METER BOXES FOR THE HERNANDO COUNTY UTILITIES DEPARTMENT. SUBMIT PRICING ON BID FORM IN SECTION VI (SEE ATTACHED SPECIFICATIONS)	XXXX	XXXX	XXXXXXXX	\$ _____

OFFER

(TERMS, CONDITIONS AND SPECIFICATIONS ARE INCLUDED AS PARTS HEREOF)

IN COMPLIANCE WITH THE ABOVE, THE UNDERSIGNED, BEING DULY AUTHORIZED TO SIGN THIS BID FOR THE BIDDER, AGREES THAT IF THIS OFFER IS ACCEPTED WITHIN **NINETY (90) DAYS** FROM THE BID OPENING DATE, TO FURNISH TO HERNANDO COUNTY ANY AND ALL ITEMS FOR WHICH PRICES ARE OFFERED IN THIS BID SOLICITATION AT THE PRICE(S) SO OFFERED, DELIVERED AT DESIGNATED POINT(S), WITHIN THE TIME PERIOD SPECIFIED, AND AT THE TERMS AND CONDITIONS SO STIPULATED IN THE SOLICITATION FOR BIDS.

DISCOUNT FOR PROMPT PAYMENT: % 10 CALENDAR DAYS % 20 CALENDAR DAYS % CALENDAR DAYS	
BIDDER'S INFORMATION	NAME AND TITLE OF PERSON AUTHORIZED TO SIGN BID OFFER:
Company Name _____	BIDDER'S SIGNATURE _____ OFFER DATE _____
Address _____	
City _____ State _____ Zip Code _____	
Phone Number _____ Fax Number _____ Email Address _____	

AWARD

(TO BE COMPLETED BY COUNTY)

REVIEWED FOR LEGAL SUFFICIENCY:	LR NO.:	BY:
ACCEPTED AS TO ITEM(S) NO:	AMOUNT:	ACCOUNTING CODE:
SUBMIT INVOICES TO: HERNANDO COUNTY UTILITIES DEPARTMENT 15365 CORTEZ BOULEVARD BROOKSVILLE, FL 34613	NAME AND TITLE OF PERSON AUTHORIZED TO SIGN ACCEPTANCE AND AWARD FOR THE COUNTY:	
	SIGNATURE:	AWARD DATE:

67. TECHNICAL SPECIFICATIONS:**67.1. GENERAL:**

- 67.1.1. Meter box shall be black and constructed of modified polyethylene material for maximum durability and corrosion resistance. The black material is for maximum Ultraviolet (UV) protection.
- 67.1.2. The black material shall be uniform throughout the meter box for maximum longevity and not have a foaming agent that creates air pockets within the plastic wall.
- 67.1.3. Vertical and Lateral Load Rating:
- 67.1.3.1. Compliant with American Association of State Highway and Transportation Officials (AASHTO), Design Load of H-10; ASTM C 857-95, Design Load of A-8, 8,000 lbs., transferred through a 10' x 10' steel plate centered in the cover and body.
- 67.1.3.2. Compliant with AASHTO, Design Load of H-20, International Standards Organization ASTM 857-95, Design Load of A-16, 16,000 lbs., transferred through a 10' x 20' steel plate centered on the cover and body.
- 67.1.3.3. Product shall be designed to withstand H-10 and H-20 loading in non-deliberate or incidental traffic areas.

67.2. POLYMER LID:

- 67.2.1. The polymer lid shall have a molded picket hole pocket (3" x 9/16" x 1.25" deep with 3/16" 304 stainless steel (SS) rod).
- 67.2.2. The polymer lid shall have "Hernando County Utilities Dept" molded into the lid. Font shall be Std Fadal Computer Numerical Control (CNC) font with 0.5" characters x 0.125" deep.
- 67.2.3. The polymer lid shall seat securely and evenly inside the meter box and shall not overlap the top edge of the meter box.
- 67.2.4. The polymer lid shall seat securely and evenly inside the concrete meter box and shall not overlap the top edge of the concrete meter box of similar dimensions.
- 67.2.5. The polymer lid shall have three (3) pieces of 1/2" rebar located in the lid as illustrated in the supplied exhibits for locatability and resistance to floating.
- 67.2.6. The polymer lid shall have a molded tread-pattern for skid resistance – tread dimensions shall be 0.188" x 0.938" x 0.150" deep.
- 67.2.7. The polymer lid shall have "Water Meter" molded into the lid. Font shall be Std Fadal Computer Numerical Control (CNC) font with 1" characters x 0.150" deep.
- 67.2.8. The polymer lid shall retrofit existing concrete meter boxes with similar dimensions and be able to adjust in the field.
- 67.2.9. The polymer lid shall be black and have a molded recycled emblem with a minimum of 50% Post-Consumer Recycled and 50% Post Industrial/Pre-Consumer Recycled Content – verified with Leed Product Documentation.
- 67.2.10. The polymer lid shall be DFW Plastics, Inc. or equal.

67.3. POLYMER BODY:

- 67.3.1. The polymer body shall be flared and have a minimum of 3/8" wall thickness.
- 67.3.2. The polymer body shall have a minimum inside working room of 22-9/16" x 16-1/16".

SECTION VI – BID FORM

ITB NO. 22-R00124/JG – PURCHASE OF METER BOXES AS NEEDED

The Vendor/Contractor shall provide all labor and other resources necessary to provide the supplies, equipment and/or services in strict accordance with the specifications defined in this solicitation for the amounts specified in this Bid Form, inclusive of overhead, profit, and any other costs.

There are no guarantees that the County will utilize the per year estimates and may exceed the quantities identified.

METER BOX AND LID DESCRIPTIONS – ESTIMATED ANNUAL QUANTITIES

ITEM NO.	DESCRIPTION	QTY.	UNIT	UNIT PRICE	TOTAL AMOUNT
1	DFW37F-12-1EP-BODY Single Meter Box (5/8", 3/4", 1" meters) (Exhibit "A") DFW Plastics Inc. or equivalent	700	EA		
2	DFW39F-12EA-BODY Double Meter Box (5/8", 3/4", 1" meters) (Exhibit "B") DFW Plastics Inc. or equivalent	1600	EA		
3	DFW1730F-18-BODY Single Vault Box (1.5" & 2" meters) (Exhibit "C") DFW Plastics Inc. or equivalent	100	EA		
4	DFW37C-1EP-LID HERN Single Box Lid (Exhibit "A") DFW Plastics Inc. or equivalent	700	EA		
5	DFW39F-1EA-LID HERN Dual Box Lid (Exhibit "B") DFW Plastics Inc. or equivalent	1600	EA		
6	DFW1730F-1EA HERN Single Vault LID (Exhibit "C") DFW Plastics Inc. or equivalent	100	EA		

TOTAL BASE BID: _____

TOTAL BASE BID (in words): _____

Company Name

Authorized Signature

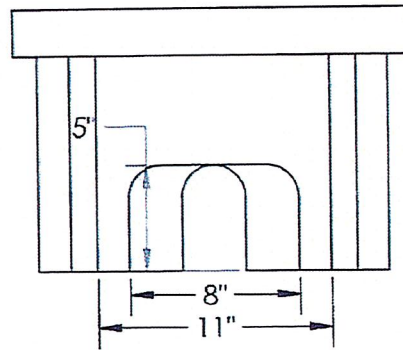
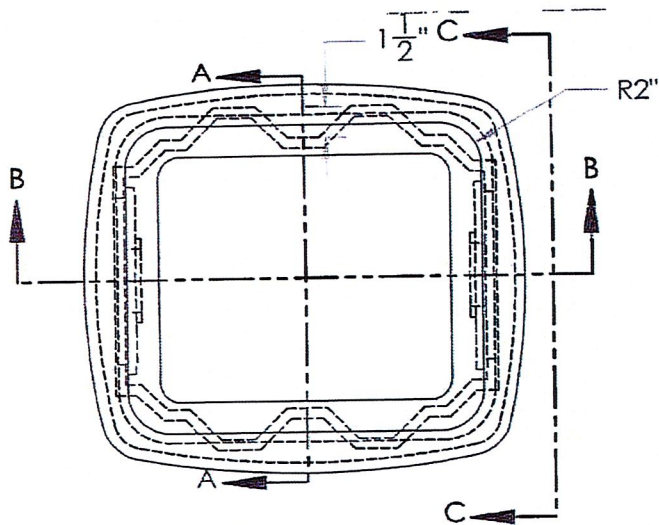

SECTION C-C

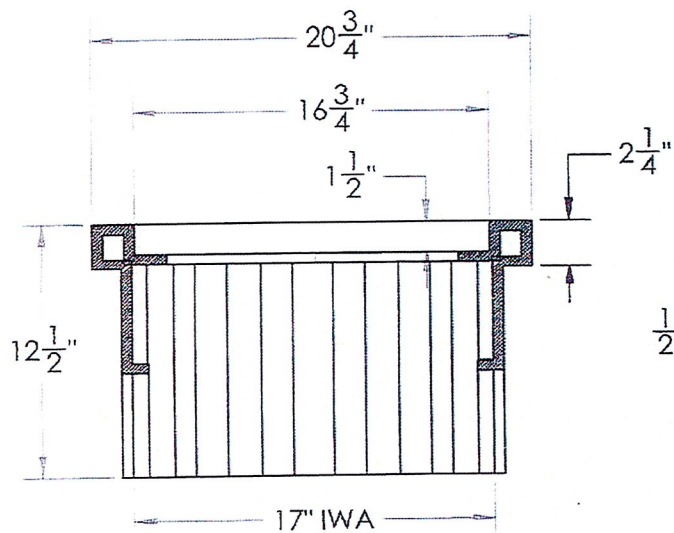
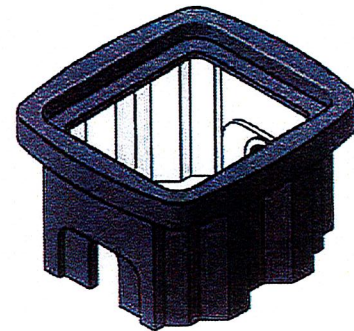

SECTION B-B

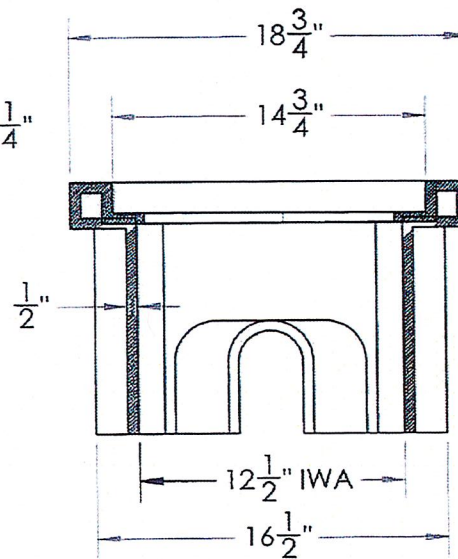

SECTION A-A

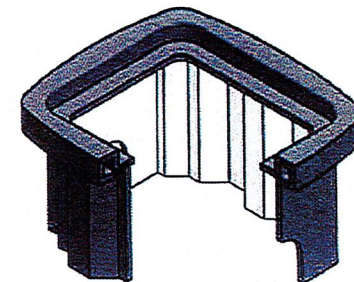

← STRAIGHT WALL

ALL DIMENSIONS ARE IN INCHES
DIMENSIONAL TOLERANCE +/- 1/8"

SIGMA

RMB 141612-NSW-W

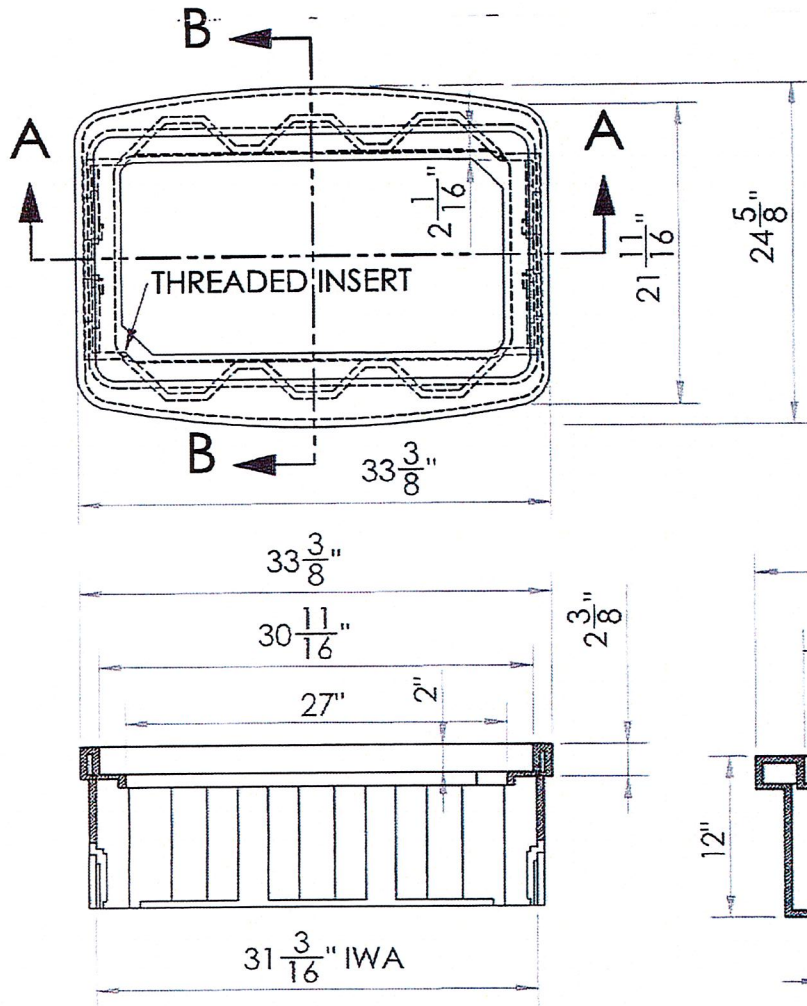

SECTION A-A
SCALE 1 : 12

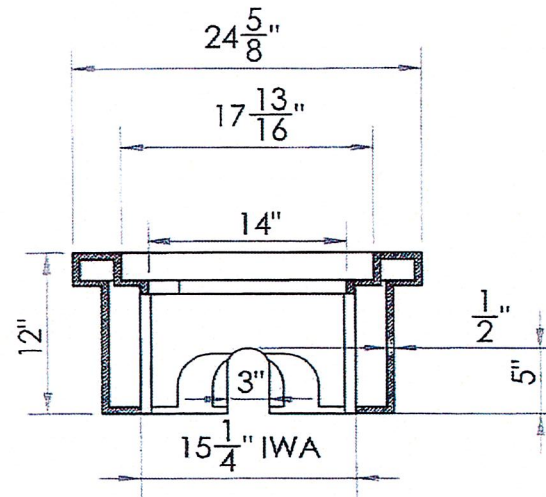

SECTION B-B
SCALE 1 : 12

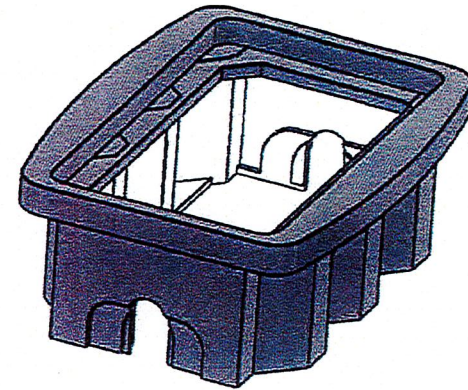

ALL DIMENSIONS ARE IN INCHES
DIMENSIONAL TOLERANCE +/- 1/8"

SIGMA.
RMB 173012NSW-W REV 1

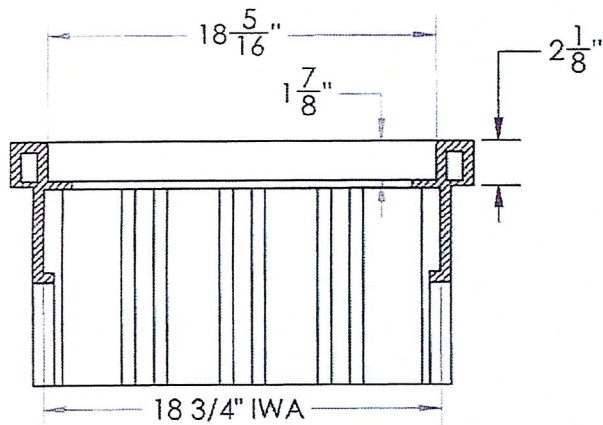
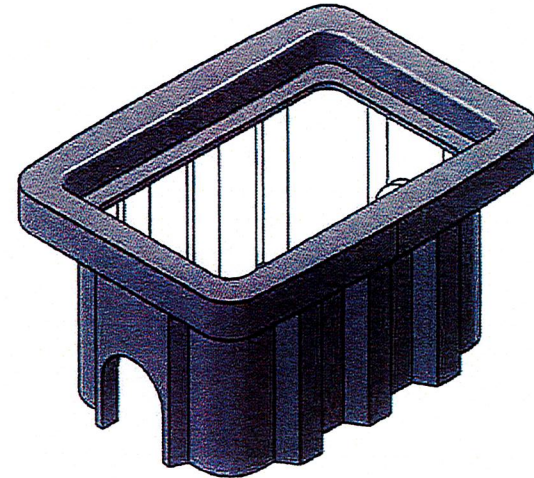
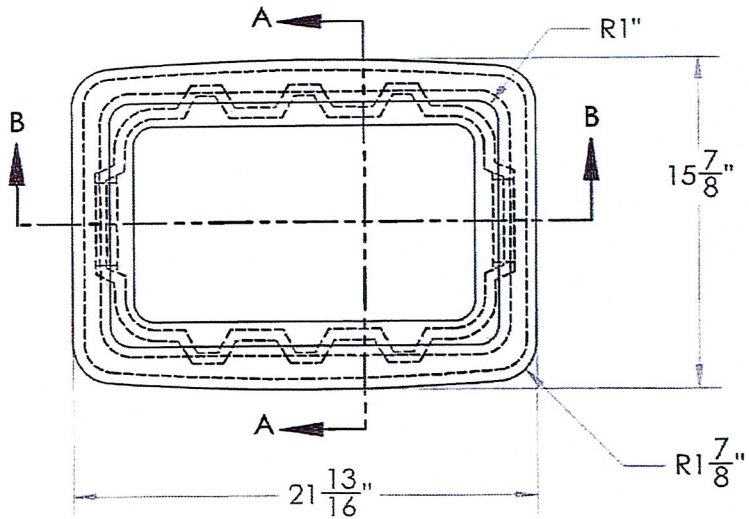

SECTION B-B

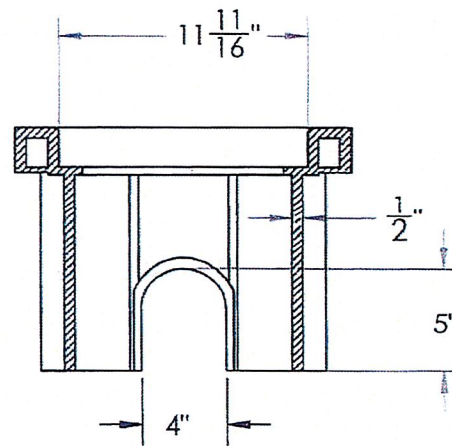

SECTION A-A

ALL DIMENSIONS ARE IN INCHES
 DIMENSIONAL TOLERANCE $\pm 1/8"$

 **SIGMA.**

RMB 111812 NSW-W