

# CONSTRUCTION OF FIRE STATION 15

26-C01265/GB

County of Hernando  
15470 Flight Path Drive  
Brooksville, FL 34604



County of Hernando  
Construction of Fire Station 15

I.	SOLICITATION .....
II.	INTRODUCTION.....
III.	AWARD .....
IV.	DEFINITIONS AND SOLICITATION INSTRUCTIONS.....
V.	GENERAL CONDITIONS.....
VI.	SPECIAL CONDITIONS.....
VII.	SCOPE AND SPECIFICATIONS.....
VIII.	PRICING PROPOSAL.....
IX.	VENDOR QUESTIONNAIRE (CONSTRUCTION).....

Attachments:

- A - Construction Documents required after Award
- B - Construction Plan Portfolio FS15
- C - Phase I ESA Report FS15
- D - Sample Construction Contract

## 1. SOLICITATION

**ISSUED BY:**

BOARD OF COUNTY COMMISSIONERS

HERNANDO COUNTY, FLORIDA

Jerry Campbell, Chairman

Ryan Amsler, Vice Chairman

Steve Champion, Second Vice Chairman

Brian Hawkins

John Alloco

**SUBMIT BID OFFER TO:**

HERNANDO COUNTY

PROCUREMENT DEPARTMENT

via Hernando County's [eProcurement Portal](#)

Carla Rossiter-Smith

Chief Procurement Officer

SEALED OFFERS, FOR FURNISHING THE SERVICES, SUPPLIES OR EQUIPMENT DESCRIBED HEREIN WILL BE RECEIVED BY THE OFFICE OF PROCUREMENT, VIA THE COUNTY'S [eProcurement Portal](#) UNTIL 10:00 a.m., LOCAL TIME ON Monday, March 9, 2026. NO BID OFFERS WILL BE ACCEPTED AFTER THE ABOVE STIPULATED DATE AND TIME. THIS IS AN ADVERTISED SOLICITATION AND THE RESPONDING BIDDERS WILL BE PUBLICLY READ AT 15470 FLIGHT PATH DRIVE BROOKSVILLE, FL 34604 IN THE ADMINISTRATIVE CONFERENCE ROOM AT 10:00 a.m. ON Monday, March 9, 2026. PURSUANT TO FS 119.071 SEALED BIDS, PROPOSALS, OR REPLIES RECEIVED BY AN AGENCY PURSUANT TO A COMPETITIVE SOLICITATION ARE EXEMPT FROM INSPECTION UNTIL SUCH TIME AS THE AGENCY PROVIDES NOTICE OF AN INTENDED DECISION OR UNTIL THIRTY (30) DAYS AFTER OPENING THE BIDS, PROPOSALS, OR FINAL REPLIES, WHICHEVER IS EARLIER.

Procurement Contact Information:

Gretchen Bechtel, Contract Agent II

(352) 754-4013

[gbechtel@co.hernando.fl.us](mailto:gbechtel@co.hernando.fl.us)

## 2. INTRODUCTION

### 2.1. ADVERTISEMENT OF BID

#### INVITATION TO BID

NOTICE IS HEREBY GIVEN that the Board of County Commissioners of Hernando County, Florida, is accepting Bids for:

CONSTRUCTION CONTRACT ITB SOLICITATION NO. 26-C01265/GB

FOR

Construction of Fire Station 15

Hernando County Board of County Commissioners is soliciting licensed general contractors with multiple trade disciplines to include but not limited to electrical, mechanical HVAC, plumbing, fire suppression, and utilities that are active in the construction of a new fire station to include a three (3) bay apparatus wing and crew quarters complete with kitchen, living, laundry, hazardous wash area, storage, restrooms, and a new emergency traffic light installed on US Highway 19.

Offers for furnishing the above will be received and accepted up to 10:00 a.m. (local time), Monday, March 9, 2026, via Hernando County Procurement Department's [eProcurement Portal](#). Only electronic submittals shall be accepted by the County.

The Board of County Commissioners of Hernando County, Florida reserves the right to accept or reject any or all bids and waive informalities and minor irregularities in offers received in accordance with the bid documents and the Hernando County Procurement Ordinance.

Interested firms may secure the bid documents and plans and drawings and all other pertinent information by visiting the County's eProcurement Portal. For additional project information, please visit the Hernando County Board of County Commissioners Procurement Department at [www.hernandocounty.us](http://www.hernandocounty.us), or by submitting a question via the Q&A Tab in the County's [eProcurement Portal](#).

Bid offers shall be accompanied by either a Bid Bond, Certified Check, Cashier's Check, or Official Bank Check in the dollar amount representing not less than five percent (5%) of the total amount bid as a guarantee to enter into a contract and furnish a contract performance and payment bond in the amount

of one hundred percent (100%) of the total bid price within fifteen (15) calendar days from the date of notification of the award.

Ex parte Communication: Please note that to ensure the proper and fair evaluation of a submittal, the County prohibits ex parte communication (i.e., unsolicited) initiated by the Respondent to the County official or employee evaluating or considering the submittals prior to the time a decision has been made. Communication between Respondent and the County will be initiated by the appropriate County official or employee in order to obtain information or clarification needed to develop a proper and accurate evaluation of the submittal. Ex parte communication may be grounds for disqualifying the offending Respondent from consideration or award of the solicitation or any future solicitation.

The Procurement Department will post addenda on [eProcurement Portal](#) to all questions in accordance with the Solicitation Instructions. It is the responsibility of prospective Bidders to visit the County's portal to ensure that they are aware of all Addenda issued relative to this Solicitation.

Per sec. 119.071, F.S., sealed bids, proposals or replies received by an agency pursuant to a competitive Solicitation are exempt from inspection until such time as the agency provides notice of an intended decision or until thirty (30) days after opening the bids, proposals, or final replies whichever is earlier.

#### NOTICE TO BIDDERS

To ensure that each bid is responsive, respondents are encouraged to request clarification or guidance on any aspect of the solicitation prior to the submission of bid response. Requests for clarification shall be submitted exclusively through the Q&A Tab in the County's [eProcurement Portal](#).

### 2.2. MANDATORY Pre-Bid Conference

MANDATORY Pre-Bid Conference will be held

Wednesday, February 11, 2026,

at 10:00 a.m.,

at the

Hernando County Administration Building 15470 Flight Path Drive Brooksville, FL 34604.

Representatives of Owner will be present to discuss the project. Bidders are recommended to attend and participate in the conference. THIS CONFERENCE WILL BE HELD ONLY ONCE AND FAILURE TO ATTEND AND SIGN IN SHALL DISQUALIFY ANY BIDDER NOT ATTENDING FROM SUBMITTING A BID. ATTENDEES MUST BE PRESENT AT THE START OF THE PRE-BID CONFERENCE. ARRIVAL AFTER THE START OF THE PRE-BID CONFERENCE SHALL BE CAUSE FOR DISQUALIFICATION.

### **3. AWARD**

UPON AWARD, PLEASE SUBMIT INVOICES TO:

Hernando County

Fire & EMS

15470 Flight Path Dr.

Brooksville, Florida 34604

## 4. DEFINITIONS AND SOLICITATION INSTRUCTIONS

### 4.1. DEFINITION OF TERMS

**DEFINITION OF TERMS** Where the following terms, or their pronouns, occur herein, the intent and meaning shall be as follows:

- A. **ADDENDA:** Written or graphic instruments issued prior to the opening of bids which clarify, correct, or change the bidding requirements or the proposed Contract Documents.
- B. **AGREEMENT:** The written instrument which is evidence of the Agreement between Owner and Vendor/Contractor covering the work.
- C. **APPLICATION FOR PAYMENT:** The form acceptable to Engineer which is to be used by Vendor/Contractor during the course of the work in requesting progress or final payments and which is to be accompanied by such supporting documentation as is required by the Contract Documents.
- D. **BID:** The offer or proposal of a Bidder submitted on the prescribed form setting forth the prices for the work to be performed.
- E. **BID BOND/GUARANTEE:** The certified check or surety bond furnished by the Bidder with his bid as evidence of good faith.
- F. **BID DOCUMENTS:** The bidding requirements and the proposed Contract Documents, including all addenda.
- G. **BIDDER:** The term "Bidder" used herein refers to the dealer/manufacturer or business organization submitting a bid to the County in response to this Solicitation.
- H. **CHANGE ORDER:** A document recommended by Engineer which is signed by Vendor/Contractor and Owner and Agency and authorizes an addition, deletion, or revision in the work or an adjustment in the contract price or the contract times, issued on or after the Effective Date of the Agreement.
- I. **CONSTRUCTION ADMINISTRATOR:** Erik van de Boogaard, shall act as the "Construction Administrator" for the work relative to the acceptance and approval of Applications for Payment pursuant to the provisions of the Florida Prompt Payment Act, Part VII, sec. 218.735, F.S.
- J. **CONTRACT:** The Agreement executed by the Owner and Vendor/Contractor for the performance of work and the other documents (plans, specifications, notice to Bidders, proposal, surety bonds, addenda and other incorporated or referenced documents) whether attached thereto or not.
- K. **CONTRACT PRICE:** The moneys payable by Owner to Vendor/Contractor for completion of the work in accordance with the Contract Documents as stated in the Agreement.

- L. **CONTRACT TIMES:** The number of days within which, or the dates by which, the work is to be substantially completed and ready for final payment as set forth in the Agreement. The contract times will commence on the date indicated in the Notice to Proceed.
- M. **CONTRACT WORK:** Any and all obligations, duties and responsibilities necessary to the successful completion of the project assigned to or undertaken by the Vendor/Contractor under the Contract Documents, including the furnishing of all labor, materials, equipment, and other incidentals.
- N. **CONTRACTOR:** The individual or entity with whom the County has entered into the Agreement.
- O. **COUNTY:** The Board of County Commissioners, Hernando County, or its duly authorized representative.
- P. **ENGINEER:** Under Contract to the Owner, the Engineer in the administration of this Contract and any references to the Engineer or the Professional shall be deemed to mean Wannemacher-Jensen Architects, for the plans and specifications referenced in these contract documents. Engineer may delegate or designate certain duties to be performed by other qualified professionals.
- Q. **FDEP:** Florida Department of Environmental Protection
- R. **FDOT:** Florida Department of Transportation.
- S. **FIELD ORDER:** A written order issued by Engineer which requires minor changes in the work but which does not involve a change in the contract price or the contract times.
- T. **ISSUING OFFICE:** The office from which the bid documents are to be issued and where the bidding procedures are to be administered. Specifically - Hernando County, Procurement Department, 15470 Flight Path Drive, Brooksville, Florida 34604.
- U. **MUTCD:** Manual on Uniform Traffic Control Devices <https://mutcd.fhwa.dot.gov>
- V. **NATIONAL POLLUTANT DISCHARGE ELIMINATION SYSTEM:** NPDES
- W. **NOTICE-WRITTEN:** Notice shall be served upon the Vendor/Contractor either personally or by leaving the said notice at his residence or with his Agent in charge of the work, or addressed to the Vendor/Contractor at the residence or place of business given in the bid and deposited in a postpaid wrapper in any post box regularly maintained by the United States Post Office.
- X. **MOT:** Maintenance of Traffic.
- Y. **NOTICE OF AWARD:** The written notice by Owner to the successful Bidder stating that upon timely compliance by the successful Bidder with the conditions precedent listed therein, Owner will sign and deliver the Agreement.
- Z. **NOTICE OF INTENT:** NOI

AA. **NOTICE TO PROCEED:** A written notice given by Owner to Vendor/Contractor fixing the date on which the contract times will commence to run and on which Vendor/Contractor shall start to perform the work under the Contract Documents. A Notice to Proceed may be given at any time after the effective date of the Agreement.

BB. **OCCUPATIONAL SAFETY AND HEALTH ACT:** OSHA.

CC. **OWNER:** Hernando County Board of County Commissioners (County).

DD. **OWNER DESIGNATED REPRESENTATIVE:** The Owner Designated Representative will act as the Owner's representative, assume all duties and responsibilities, and have the rights and authority assigned to the Owner Designated Representative in the Contract Documents in connection with the completion of the work in accordance with their respective scope of work and the contract documents. Erik van de Boogaard, shall act as the Owner Designated Representative for the work relative to this contract.

EE. **PAYMENT AND PERFORMANCE BONDS:** The approved forms of security furnished by the Vendor/Contractor and his surety as a guaranty on the part of the Vendor/Contractor to execute the work in accordance with the terms of the contract and to pay all obligations associated with the project.

FF. **PROJECT BUDGET/ESTIMATE:** The project budget and/or estimate is the amount of funds the county has projected for this solicitation. The County estimates this solicitation to fall within the following dollar Threshold G: \$2,500,000.01- \$5,000,000. **Note: This is only an estimate and should not be the basis to determine the Vendor/Contractor bid submission amount.**

1. Threshold A: less than \$100,000.00
2. Threshold B: \$100,000.01 - \$250,000
3. Threshold C: \$250,000.01 - \$500,000
4. Threshold D: \$500,000.01 - \$1,000,000
5. Threshold E: \$1,000,000.01 - \$1,500,000
6. Threshold F: \$1,500,000.01 - \$2,500,000
7. Threshold G: \$2,500,000.01 - \$5,000,000
8. Threshold H: greater than \$5,000,000.

GG. **PROFESSIONAL:** The professional independent **Architectural/Engineering firm** designated to be the Engineer of Record (per Florida Administrative Code). Any references to the Engineer or the Professional shall be deemed to mean Wannemacher-Jensen Architects, and its designee for the plans and specifications referenced in these Contract Documents.

- HH. **PROJECT MANAGER:** The duly authorized representative of the County during the construction period. The Project Manager of record for this Solicitation is: Erik van de Boogaard.
- II. **SCOPE OF WORK:** All materials, labor and equipment in order to accomplish the Project, as described in the specifications and construction plans showing the proposed improvements. The Vendor/Contractor shall accomplish the work in a manner providing for the safety of their equipment and workers and for the safety of the general public.
- JJ. **SHOP DRAWINGS:** All drawings, diagrams, illustrations, brochures, schedules and other data which are prepared by the Vendor/Contractor, a subcontractor, a manufacturer, supplier or distributor and which illustrate the equipment, material and/or some portion of the work.
- KK. **SITE:** Lands or areas indicated in the Contract Documents as being furnished by Owner upon which the work is to be performed, including rights-of-way and easements for access thereto, and such other lands furnished by Owner which are designated for the use of Vendor/Contractor. The site or location for the work to be performed in this Contract will be 10270 Atlanta Avenue, Brooksville, FL 34614 .
- LL. **SUBCONTRACTOR:** Any person, firm or corporation other than employees of the Vendor/Contractor who or which contracts with the Vendor/Contractor to furnish, or actually furnishes labor, materials and/or equipment for the performance of a part of the work on the project.
- MM. **SURETY:** Any person, firm or corporation which is bound by Public Construction Bond and Payment Bond with and for the Vendor/Contractor and which engages to be responsible for his acceptable performance of the work and for payment of all debts pertaining thereto.
- NN. **VENDOR/CONTRACTOR:** The individual or entity with whom the County has entered into the Agreement.
- OO. **WORK:** The entire completed construction or the various separately identifiable parts thereof required to be furnished under the Contract Documents. Work is the result of performing services, furnishing labor and furnishing and incorporating materials and equipment into the construction, all as required by the Contract Documents.

#### 4.2. AVAILABILITY OF BIDDING DOCUMENTS:

Interested firms may secure bid documents, plans, drawings, site locations, and other pertinent information by visiting Hernando County's [eProcurement Portal](#). For additional information please contact the Hernando County Board of County Commissioners, Procurement Department via the County's [eProcurement Portal](#) Q&A Tab.

### 4.3. PREPARATION OF BID

To ensure acceptance of your bid, please follow these instructions:

- A. Interested firms are required to register via the County's [eProcurement Portal](#). Once registered, to submit a response please click on the "DRAFT RESPONSE" button and provide an answer to all of the prompts/questions. You must respond to all required questions, and, if any, acknowledge addenda so that your response will be considered complete by the County. Bidders submitting more than one (1) bid with different pricing shall cause the Bidder to be rejected. All bids are subject to the conditions specified herein. Those, which do not comply with these conditions, may be subject to rejection.
  
- B. Submit Bids via the Hernando County's [eProcurement Portal](#). The responsibility for delivering the bid to the County on or before the stated time and date will be solely and strictly the responsibility of the Bidder. The County will be in no way responsible for delays caused by wi-fi connection or speed, power outage or any other occurrence.
  - 1. Bids will be rejected unless submitted electronically via the County's eProcurement Portal along with all required bid line items. All bid forms enclosed are required to be completed and submitted using the instructions listed herein.
  - 2. The County will not honor any explanation or change in the bid documents unless a written addendum authorizing such change has been issued.
  - 3. The County reserves the right to reject any and all bids and to waive any informalities related thereto.
  - 4. All bids must be firm for a period of one hundred twenty (120) days after the time set for opening bids. Upon award, prices quoted will be in effect for the term of the contract.
  - 5. No material, labor, or facilities will be furnished by the County unless specifically stated.
  - 6. Blank spaces in the bid must be properly filled in and the phraseology of the bid must not be changed. Additions must not be made to items mentioned therein and any unauthorized conditions, limiting any provision, attached to a bid shall render irregular and may cause its rejection.
  - 7. Bidders are expected to make all investigations necessary to thoroughly inform themselves regarding all drawings, specifications, delivery requirements, performance requirements, site locations and all solicitation instructions to satisfy themselves of conditions affecting submission of their bid and the terms and cost of performing the contract. No pleas of ignorance by the Bidder of conditions that exist or may hereafter exist as a result of failure or omission on the part of the Bidder to make the necessary examinations and investigations, or failure to fulfill in every detail the requirements of the contract documents, will be accepted as a basis of varying the requirements of the County or the

compensation of the Bidder. Bidder agrees that submittal of a bid for the work is prima facie evidence they have conducted such examinations.

8. Communications: All technical, scope, and/or project related questions shall be submitted through the project [eProcurement Portal](#) Q&A Tab before the deadline and according to these specifications herein. Any and all other bidding communications shall only be to the County's Procurement representative using the contact information herein. Companies bidding on this project shall not communicate with any other County Staff members or they risk being disqualified.

#### 4.4. [BID OPENING](#)

Bids received after the date and time disclosed in this Solicitation will not be accepted. Bids will be opened immediately after this date and time, and will remain binding upon the Bidder for a period of one hundred twenty (120) days thereafter. Pursuant to sec. 119.071 F.S., sealed bids, proposals, or replies received by an agency pursuant to a competitive solicitation are exempt from inspection until such time as the agency provides notice of an intended decision or until thirty (30) days after opening the bids, proposals, or final replies whichever is earlier.

#### 4.5. [SITE VISIT](#)

Bidder may request access the site to conduct examinations, investigations, explorations, tests, and studies as Bidder deems necessary for submission of a bid by contacting the Procurement Department via the County's [eProcurement Portal](#) Q&A Tab, if no mandatory site visit is scheduled. All questions after the site visit shall be submitted to the Procurement Department in writing via the County's [eProcurement Portal](#) Q&A Tab. The Procurement Department will coordinate a site visit between the Bidder and the Project Manager for this project. Bidder agrees to restore the site to its former condition upon completion of such explorations, investigations, tests, and studies. Bidder shall comply with all applicable laws and regulations relative to excavation and utility locates while accessing the site.

#### 4.6. [BIDDER'S RESPONSIBILITIES](#)

It is the responsibility of each Bidder before submitting a bid to:

- A. Read and completely understand the requirements and the specifications of the items bid.
- B. Use complete sets of bid documents in preparing bids; neither Owner nor Engineer assumes any responsibility for errors or misinterpretations resulting from the use of incomplete sets of bid documents.
- C. Examine and carefully study the bid documents, other related data identified in the bid documents, and any Addenda.
- D. Make all investigations necessary to thoroughly inform themselves regarding all drawings, specifications, delivery requirements, performance requirements, site locations, and all solicitation instruction to satisfy themselves of conditions affecting submission of their bid and the terms and cost of performing the contract. No pleas of ignorance by the Bidder of conditions

that exist or may hereafter exist as a result of failure or omission on the part of the Bidder to make the necessary examinations and investigations, or failure to fulfill in every detail the requirements of the Contract Documents, will be accepted as a basis of varying the requirements of the County or the compensation of the Bidder. Bidder agrees that submittal of a bid for the work is prima facie evidence they have conducted such examinations.

- E. Request access to the site to become familiar with general, local, and site conditions that may affect cost, progress, and performance of the work.
- F. Become familiar with all Federal, State, and local laws and regulations that may affect cost, progress, or performance of the work.
- G. Obtain and carefully study all additional or supplementary examinations, investigations, explorations, tests, studies, and data concerning conditions (surface, subsurface, and underground facilities) at or contiguous to the site which may affect cost, progress, or performance of the work or which relate to any aspect of the means, methods, techniques, sequences, and procedures of construction to be employed by the Bidder, including applying any specific means, methods, techniques, sequences, and procedures of construction expressly required by the bid documents, and safety precautions and programs incident thereto.
- H. Agree at the time of submitting its bid that no further examinations, investigations, explorations, tests, studies, or data are necessary for the determination of its bid for performance of the work at the price(s) bid and within the times and in accordance with the other terms and conditions of the bid documents.
- I. Become aware of the general nature of the work to be performed by Owner and others at the site that relates to the work as indicated in the bid documents.
- J. Correlate the information known to Bidder, information and observations obtained from visits to the site, reports and drawings identified in the bid documents, and all additional examinations, investigations, explorations, tests, studies, and data with the bid documents.
- K. Promptly give Engineer written notice of all conflicts, errors, ambiguities, or discrepancies that Bidder discovers in the bid documents and confirm that the written resolution thereof by Engineer is acceptable to Bidder.
- L. Determine that the bid documents are generally sufficient to indicate and convey understanding of all terms and conditions for the performance of the work.
- M. Bidder accepts all of the terms and conditions of the Instructions to Bidders, including without limitation those dealing with the disposition of bid security. This bid will remain subject to acceptance for one hundred twenty (120) days after the bid opening, or for such longer period of time that Bidder may agree to in writing upon request of Owner.

- N. Bidder has enclosed a Certified check, Cashier's Check or Bid Bond in the amount of not less than the five percent (5%) of the Total Base Bid Amount payable to the Hernando County Board of County Commissioners as a guarantee for the purpose set out in the Instructions to Bidders.

#### 4.7. QUESTIONS REGARDING SPECIFICATIONS OR BIDDING PROCESS:

To ensure fair consideration for all Bidders, the County prohibits communication to or with any department, division or employee during the bid process, except as provided below:

- A. All questions relative to interpretation of the specifications or the bid process shall be addressed in writing via Hernando County's [eProcurement Portal](#) Q&A Tab, prior to the date set for submittal and opening of the bids.
- B. Any interpretation or clarification made to prospective Bidders will be expressed in the form of an addendum which, if issued, will be posted on the County's [eProcurement Portal](#) Q&A Tab. Oral answers will not be authoritative.
- C. It will be the responsibility of the Bidder to visit [eProcurement Portal](#) to insure they are aware of all addenda issued for this solicitation.
- D. Questions will only be accepted through the period specified Monday, March 2, 2026
- E. All addenda must be acknowledged via the County's eProcurement Portal. Failure of any Bidder to acknowledge any addenda may be found non-responsive and subject to rejection.

#### 4.8. COMMUNICATION

There shall be no communication between the Vendor/Contractor, their employees or subcontractors and County employees and elected officials (hereafter referred to as "County Representative"), except through the Procurement Department. Any attempt to communicate with any County Representative outside the Procurement Department will be considered a violation of the Procurement Policy and may result in the rejection of your bid.

#### 4.9. WITHDRAWAL OF BIDS:

Bids may be withdrawn only through the County's [eProcurement Portal](#) prior to Monday, March 9, 2026, 10:00 am. Negligence on the part of the Bidder in preparing the bid confers no right for the withdrawal of the Bid after it has been opened. No Bidder may withdraw their bid after the scheduled opening time for receipt of bids.

#### 4.10. BID PROTESTS

Any Bidder who protests the Bid Specifications or Award or Intent to Award, must file with the County a notice of protest and formal written protest in compliance with the Hernando County Procurement Manual, Section 22, which can be found at [procurement-manual v-july-2025.pdf](#). Failure to timely file such documents will constitute a waiver of proceedings. Failure to file a protest within the time

prescribed by, or failure to post the bond or other security in strict accordance with, the Hernando County Procurement Manual, Section 22, shall constitute a waiver of protest proceedings.

#### 4.11. QUALIFICATION OF BIDDERS

- A. The Vendor/Contractor shall have previous experience in the type of construction work specified herein, and experience in the installation of the materials to be provided for the project specified herein.
- B. The Vendor/Contractor and/or subcontractors shall be an appropriately licensed Contractor in the State of Florida at the time of the bid and must have successfully completed a minimum of two (2) projects of similar size and complexity in the past seven (7) years. These requirements are in addition to the requirements in Section entitled, "Reference Documents" below.
- C. The Vendor/Contractor's Project Superintendent must have a minimum of three (3) years' experience as Project Superintendent and must have directed at least two (2) previous projects of similar size and complexity. These requirements are in addition to the requirements in Section entitled, "Reference Documents."
- D. Bidders shall submit evidence of this experience on the forms provided in the bid documents, along with the accompanying information requested below:
  - 1. Overview of construction experience, including a list of projects successfully completed and indicating Owner, location, contract value and completion date.
  - 2. Documentation of two (2) projects, similar in scope and complexity to this project, which have been successfully completed by the Bidder within the past seven (7) years.
  - 3. Identification of firms comprising the Vendor/Contractor's team on the Construction Contractor Qualification Submittal Package attached to Vendor Questionnaire.
  - 4. Resumes of the Vendor/Contractor's Project Superintendent documenting the experience required for these individuals.
- E. **Failure to submit this information may be basis for rejection of the bid.**

#### 4.12. QUALIFICATION OF SUBCONTRACTORS, MATERIAL VENDOR, SUPPLIERS, AND OTHERS:

- A. The Vendor/Contractor will, within ten (10) days after execution of the Agreement, submit to the County through the Owner Designated Representative for acceptance a list of the names of subcontractors and such other persons and organizations proposed for those portions of the work as to which the identity of the subcontractors and other persons and organizations must be submitted as specified in the Contract Documents. The Owner Designated Representative will notify the Vendor/Contractor in writing if the Owner Designated Representative, after due investigation, has reasonable objection to any subcontractor, person or organization on such list. The failure of the Owner Designated Representative to make objections to any

subcontractor, person or organization on the list shall constitute an acceptance of such subcontractor, person or organization. Acceptance of any such subcontractor, person or organization shall not constitute a waiver of any right of the County to reject defective work, material or equipment, or work material or equipment not in conformance with the requirements of the Contract Documents.

- B. If the apparent successful Bidder declines to make any such substitution, County may award the Contract to the next lowest responsive, responsible Bidder that proposes to use acceptable subcontractors, suppliers, individuals, or entities. Declining to make requested substitutions will not constitute grounds for forfeiture of the bid security of any Bidder. Any subcontractor, supplier, individual, or entity so listed and against which the County and Owner Designated Representative makes no written objection prior to the giving of the Notice of Award will be deemed acceptable to the County and Owner Designated Representative subject to revocation of such acceptance after the effective date of the Agreement.
- C. Vendor/Contractor shall not be required to employ any subcontractor, supplier, individual, or entity against whom Vendor/Contractor has reasonable objection.
- D. The Vendor/Contractor agrees that he is as fully responsible to the County for the acts and omissions of his subcontractors and of persons either directly or indirectly employed by them, as he is for the acts and omissions of persons directly employed by him. Nothing contained in the Contract Documents shall create any contractual relation between any subcontractor and the County.

#### 4.13. EXAMINATION OF BIDDING DOCUMENTS, OTHER RELATED DATA, AND SITE:

- A. Subsurface and Physical Conditions:
  - 1. The Technical Specifications will identify:
    - a. Any reports of explorations and tests of subsurface conditions at or contiguous to the site that Engineer has used in preparing the bid documents.
    - b. Any drawings of physical conditions in or relating to existing surface and subsurface structures at or contiguous to the site (except underground facilities) that Engineer has used in preparing the bid documents.
  - 2. Copies of any reports and drawings referenced in the solicitation documents will be made available by Owner to any Bidder via the County's [eProcurement Portal](#). Bidder is responsible for any interpretation or conclusion Bidder draws from any technical data or any other data, interpretations, opinions, or information contained in such reports or shown or indicated in such drawings.
- B. Underground Facilities:

1. Information and data shown or indicated in the bid documents with respect to existing underground facilities at or contiguous to the site is based upon information and data furnished to Owner and Engineer by owners of such underground facilities, including Owner, or others.

C. Hazardous Environmental Condition:

1. The Technical Specifications identify any reports and drawings relating to a hazardous environmental condition identified at the site that Engineer has used in preparing the bid documents.

**4.14. BID GUARANTEE/BID BOND:**

- A. Each bid must be accompanied by a Certified Check, Cashier's Check, Official Bank Check or Bid Bond payable to the Owner for an amount equal to at least five percent (5%) of the amount of bid, as guarantee that the Bidder will within fifteen (15) consecutive calendar days after award, enter into a written contract with the County for the performance of the work as awarded.
- B. **Any submitted Bid Bond must be submitted to the County.**
- C. Any submitted checks shall be drawn on a solvent bank or trust company to the order the Hernando County Board of County Commissioners and shall have all necessary documentary revenue stamps attached, if required by law.
- D. Surety of Bid Bonds shall be a duly authorized surety company authorized to do business in the State of Florida; all such bonds being issued or countersigned by a local producing agent who is a resident of the State of Florida and satisfactory evidence of the authority of the person or persons executing such bond being submitted with the bond. Personal checks are not acceptable to Hernando County.
- E. The County will, within ten (10) days after the Notice of Intent to Award, return the deposit of all Bidders except those posted by the three (3) lowest acceptable Bidders, whose deposit will be returned upon the final award and execution of the Contract between the successful Bidder and County, and after a satisfactory Performance Bond and Payment Bond have been executed.
- F. Attorneys-in-fact who sign bonds or other surety instruments must attach with each bond or surety instrument a certified and effectively dated copy of their power of attorney.
- G. If the successful Bidder fails to execute and deliver the Contract Documents and furnish the required contract security within fifteen (15) days after the Notice of Award, Owner may withdraw the Notice of Award and the Bid Bond of that Bidder will be forfeited. The Bid Bond of other Bidders whom Owner believes to have a reasonable chance of receiving the award may be retained by Owner until the earlier of seven (7) days after the effective date of the Agreement

or sixty-one (61) days after the bid opening, whereupon Bid Bonds furnished by such Bidders will be returned.

- H. Bid Bonds of other Bidders whom Owner believes do not have a reasonable chance of receiving the award will be returned within thirty (30) days after the Bid opening.
- I. Bidders desiring their original Bid Bonds returned shall enclose a self-addressed stamped envelope with their bids marked "Bid Bond" in the lower left corner.

#### 4.15. PERFORMANCE AND PAYMENT BOND:

- A. Performance and Payment Bond issued in a sum equal to one hundred percent (100%) of the total awarded contract amount by a surety company considered satisfactory by the County and otherwise authorized to transact business in the State of Florida will be required from the successful Bidder for purposes of insuring the faithful performance of the obligations imposed by the resulting contract and for purposes of protecting the County from lawsuits for non-payment of debts as might be incurred during the successful Bidder's performance under such contract. When applicable, the performance and payment bond form will be included in the contract documents and said form must be properly executed by the surety company and successful Bidder within fifteen (15) calendar days after notification by the County of the County's intent to award the contract.
- B. If, within fifteen (15) calendar days after notification by the County of the County's intent to award a contract, the successful Bidder refuses or otherwise neglects to execute the required written contract or fails to furnish the required performance and payment bond, the amount of the Bidder's bid security (check or Bid Bond) shall be forfeited and the same shall be retained by the County. No plea of mistake in the Bid or misunderstanding of the conditions of forfeiture shall be available to the Bidder for the recovery of his bid security or as a defense to any action based upon the neglect or refusal to execute a written contract.
- C. The surety company must provide an Increase Rider to the Performance and Payment Bond or execute the Consent of Surety and Increase of Penalty form provided by the County if the contract is increased by change order.

#### 4.16. FOREIGN COUNTRIES OF CONCERN:

Pursuant to 287.138 F.S., effective July 1, 2023, the County may not enter into contracts which grants the Vendor/Contractor access to personal identifiable information if: a) the Contractor is owned by the government of a Foreign Country of Concern (as defined by the statute); (b) the government of a Foreign Country of Concern has a controlling interest in the entity; or (c) the Contractor is organized under the law of or has its principal place of business in a Foreign Country of Concern.

Bidders/Proposers must provide a response to the section titled VENDOR QUESTIONNAIRE, Foreign Countries of Concern included in this solicitation.

Beginning July 1, 2025, a governmental entity is prohibited from extending or renewing a contract with an entity meeting the requirements of (a), (b), or (c) above, if the contract would give such entity access to an individual's personal identifying information.

## 5. GENERAL CONDITIONS

### 5.1. CONTRACT DOCUMENTS

The following constitute the Contract Documents (Title, Subtitles, Headings, Running Headlines, Table of Contents, and Indexes are used merely for convenience purposes):

#### **Solicitation**

#### **Introduction**

#### **Definitions and Solicitation Instructions**

#### **General Conditions**

#### **Special Conditions**

#### **Scope and Specifications**

#### **Attachments**

Exhibit A – Construction Documents required after Award

Exhibit B – Construction Plan Portfolio FS15

Exhibit C – Phase I ESA Report FS15

- A. All addenda issued by the County prior to the receipt of bids and all supplementary drawings issued after award of the Contract become part of the Contract Document.
- B. Amending and Supplementing Contract Documents:
  1. The Contract Documents may be amended to provide for additions, deletions, and revisions in the work or to modify the terms and conditions thereof by Change Order.
  2. The requirements of the Contract Documents may be supplemented, and minor variations and deviations in the work may be authorized, by one (1) or more of the following ways:
    - a. A field order;
    - b. Engineer's approval of a shop drawing or sample; or
    - c. Engineer's written interpretation or clarification per the provisions described in the Contract Documents.
  3. In resolving such conflicts, errors and discrepancies, the documents shall be given preference in the following order: Agreement, Specifications, Drawings, Solicitation Instructions. Within the specifications the order of preference shall be as follows: Addenda, General Conditions, Technical Specifications. Figure dimensions on drawings shall govern over scale dimensions, and the detailed drawings shall govern over general drawings. Any work that may reasonably be inferred from the specifications or drawings as being required

- to produce the intended result shall be supplied whether or not it is specifically called for. Work materials or equipment described in words which so applied have a well-known technical or trade meaning shall be deemed to refer to such recognized standards. In case of conflict the more stringent requirements shall take precedence and govern.
4. The Vendor/Contractor shall take no advantage of any error or omission in the plans or of any discrepancy between the plans and specifications, and the Engineer shall make such interpretation as may be deemed necessary for the fulfillment of the intent of the plans and specifications as construed by him and his decision shall be final.
- C. All provisions required by law to be inserted in this Contract, whether actually inserted or not.
  - D. Exhibits to this Agreement (as follows):
    1. Vendor/Contractor's Pricing Proposal (Bid).
    2. Documentation submitted by Vendor/Contractor after the Notice of Award:
      - a. Insurance Certificate.
      - b. Payment and Performance Bond.
    3. The following which may be delivered or issued on or after the effective date of the Agreement and are not attached hereto:
      - a. Notice to Proceed.
      - b. Change Order(s).
  - E. The documents listed in this paragraph are attached to the Agreement (except as expressly noted otherwise).
  - F. There are no Contract Documents other than those listed in this paragraph.
  - G. The Contract Documents may only be amended, modified, or supplemented as provided in the Contract Documents.

## 5.2. BID PRICE/SUBMITTAL REQUIREMENTS:

- A. The bid pricing shall remain firm during the period of the Contract. The bid pricing shall be inclusive of all labor, equipment, and materials as specified within this Solicitation. The bid pricing constitutes the total compensation payable to the Vendor/Contractor for performing the work.
- B. Unless otherwise stated, the bid pricing shall include all costs of packing, transporting, delivery, and services to the designated point within Hernando County.

- C. The Bidder hereby certifies that this bid is made without prior understanding, agreement, or connection with any corporation, firm, or person submitting a bid for the same materials, supplies, services, or equipment and is in all respects fair and without collusion or fraud. Further, the Bidder hereby agrees to abide by all terms and conditions of this bid and certifies that the person executing the Bid Form is authorized to sign this bid for the Bidder.
- D. Bidders shall submit a lump sum bid based on unit price line item components as indicated on the Bid Form and include a separate price for each alternate described in the bid documents and provided for in the Bid Form. The sum of each unit price line item shall be the Total Base Bid. The price for each alternate will be the amount added to or deducted from the Total Base Bid if the County selects the alternate.
- E. Discrepancies between the multiplication of units of work and unit prices will be resolved in favor of the unit prices. Discrepancies between the indicated sum of any column of figures and the correct sum thereof will be resolved in favor of the correct sum. Discrepancies between words and figures will be resolved in favor of the words.
- F. Bidder must submit all Required Forms and Certifications. Failure to submit these forms may render the bid non-responsive.

### 5.3. HOURS

All work is to be performed during regular working hours, 8:00 a.m. - 5:00 pm, unless otherwise directed by the County; Monday through Friday, except County holidays. The County may, on certain occasions, approve work outside of these times. Such exception(s) must be approved in writing by the County at least one (1) day in advance. Vendor/Contractor should provide five (5) days' notice when scheduling a County employee to be available outside the normal work hours.

### 5.4. REJECTION OF BID:

The County reserves the right to reject any and all bids. Bids which are incomplete, unbalanced, conditional, obscure or which contain additions not required, or irregularities of any kind, or which do not comply with every aspect of this Solicitation, may be rejected at the option of the County. A Bidder shall not be qualified to bid when an investigation by the Chief Procurement Officer reveals that the Bidder is delinquent on a previously awarded contract or in litigation with Hernando County regarding a previously awarded contract.

#### 5.5. MINOR INFORMALITIES AND IRREGULARITIES:

Hernando County has the right to waive minor defects or variations of a bid from the exact requirements of the specifications that do not affect price, quality, quantity, delivery, or performance time of the services being procured. If insufficient information is submitted by a Bidder with the bid for Hernando County to properly evaluate the bid, Hernando County has the right to require such additional information as it may deem necessary after the time set for receipt of bids, provided that the information requested does not change the price, quality, quantity, delivery or performance time of the services being procured. The Board of County Commissioners reserves the right to reject any or all bids in whole or in part; to award by any item, group(s) of items or in the aggregate whichever is most advantageous to the County.

#### 5.6. NON-EXCLUSIVE CONTRACT:

Award of a contract resulting from this bid imposes no obligation on the County to utilize the Vendor/Contractor for all work of this type, which may develop during the contract period. This is not an exclusive contract. The County specifically reserves the right to contract with another company for similar work if it deems such action to be in the County's best interest.

#### 5.7. NON-PERFORMANCE:

- A. Time is of the essence in this Contract and failure to deliver the services specified within the time period required shall be considered a default.
- B. In case of default, the County may procure the services from other sources and hold the Vendor/Contractor responsible for all costs occasioned thereby and may immediately cancel the Contract.

#### 5.8. ASSIGNMENT

The successful Bidder is required to perform this Contract and may not assign, transfer, convey, sublet or otherwise dispose of any award or any or all of its rights, title, or interest therein, or the resulting Contractual Agreement in whole or in part without prior written authorization given at the sole discretion of Hernando County.

#### 5.9. PUBLIC ENTITY CRIMES:

Any person submitting a bid or proposal in response to this invitation certifies that they are aware of, and in compliance with, all requirements under Section 287.133, Florida Statutes, on Public Entity Crimes. Bidders must provide a response to the section titled VENDOR QUESTIONNAIRE, Sworn Statement to Public Entity Crimes included in these bid documents.

#### 5.10. LICENSES AND PERMITS:

- A. Prior to furnishing the requested product(s) or service(s), it shall be the responsibility of the awarded Vendor/Contractor to obtain, at no additional cost to Hernando County, any and all

licenses and permits required to complete this contractual service, unless otherwise stated in the Contract Documents. These licenses and permits shall be readily available for review by the Chief Procurement Officer or his/her designee. Failure to have and/or furnish the required licenses or permits may be cause for rejection.

- B. The Vendor/Contractor is hereby notified that a list of fees for construction related County certified licenses and County issued permits can be located at:  
<https://www.hernandocounty.us/departments/departments-a-e/building-division/contractors>.
- C. The following permits are necessary for prosecution of the work. It is the Vendor/Contractor's responsibility to determine whether additional permits are required. Vendor/Contractor and/or subcontractors shall obtain and pay for required permits. Notice to Proceed will not be issued until the permits are provided to the Project Manager.
1. NPDES-NOI Permit - The NPDES-FDEP legislation and permit information can be found on this site: <https://floridadep.gov/water/stormwater>
  2. HC DPW ROW Use Permit, FDOT Right of Way Permit, Building Permit, Electrical Permit, FDEP Water Permit.
  3. FIRE LINE UNDERGROUND
  4. FIRE ALARM
  5. FIRE SPRINKLER
  6. FIRE HOOD & FIRE HOOD SUPPRESSION
- D. Vendor/Contractor and/or subcontractors shall be responsible for complying with all State of Florida and Hernando County license requirements prior to bidding on County projects and shall submit proof of licenses with the Bid. All licenses shall be in the Bidder's name or the key subcontractor's name, as listed in Questionnaire. Failure to submit proof of the required licenses shall deem the Bidder non-responsive. The following is a non-exhaustive list of the licenses necessary for prosecution of the work. It is the Vendor/Contractor's responsibility to determine if additional licenses are necessary.
1. general contractors with multiple trade disciplines to include but not limited to electrical, mechanical HVAC, plumbing, fire suppression, and utilities
- E. Vendor/Contractors and/or subcontractors who are not properly licensed and/or do not furnish proof thereof with their bid, may be deemed non-responsive and may be rejected.
- F. Owner shall assist Vendor/Contractor, when necessary, in obtaining such permits and licenses. Vendor/Contractor shall pay all governmental charges and inspection fees necessary for the prosecution of the work which are applicable at the time of opening of bids. Owner shall pay all charges of utility owners for connections for providing permanent service to the work.

### 5.11. LAWS, REGULATIONS, PERMITS AND TAXES:

- A. All applicable Federal and State laws, municipal and county ordinances, and the rules and regulations of all authorities having jurisdiction over any part of the project shall apply to the Contract throughout, and they will be deemed to be included in the Contract the same as through herein written
- B. Vendor/Contractor shall comply with County's jobsite procedures and regulations and with all applicable local, State and Federal laws, rules and regulations and shall obtain all permits required for any of the work performed hereunder. Vendor/Contractor shall procure and pay for all permits and inspections required for any of the work performed hereunder and shall furnish any bonds, security or deposits required to permit performance of the work. Vendor/Contractor shall, to the extent permissible under applicable law, comply with the jobsite provisions which validly and lawfully apply to work on the specific jobsite being performed under this Contract. County of Hernando is exempt from Federal excise taxes and all sales taxes.
- C. Vendor/Contractor shall give all notices required by and shall comply with all laws and regulations applicable to the performance of the work. Except where otherwise expressly required by applicable laws and regulations, neither Owner nor Engineer shall be responsible for monitoring Vendor/Contractor's compliance with any laws or regulations.
- D. If Vendor/Contractor performs any work knowing or having reason to know that it is contrary to laws or regulations, Vendor/Contractor shall bear all claims, costs, losses, and damages (including but not limited to all fees and charges of engineers, architects, attorneys, and other professionals and all court or arbitration or other dispute resolution costs) arising out of or relating to such work. However, it shall not be Vendor/Contractor's primary responsibility to make certain that the specifications and drawings are in accordance with laws and regulations, but this shall not relieve Vendor/Contractor of Vendor/Contractor's obligations of reporting discrepancies.
- E. Changes in laws or regulations not known at the time of opening of bids having an effect on the cost or time of performance of the work shall be the subject of an adjustment in contract price or contract times. If Owner and Vendor/Contractor are unable to agree on entitlement to or on the amount or extent, if any, of any such adjustment, a claim may be made therefore as provided in the Contract Documents.

### 5.12. SITE AND OTHER AREAS

The site is identified in the Bid documents. Easements for permanent structures or permanent changes in existing facilities are to be obtained and paid for by Owner unless otherwise provided in the Bid documents. All additional lands and access thereto required for temporary construction facilities,

construction equipment, or storage of materials and equipment to be incorporated in the work are to be obtained and paid for by Vendor/Contractor.

### 5.13. TAXES

- A. The Board of County Commissioners, Hernando County, Florida, has the following tax exemption certificates assigned:
  - 1. **Sales and Use Tax Exemption Certificate No. 85-8012556945C-8, effective 1/31/2024 – expiring on 1/31/2029.**
- B. This exemption does not apply to purchases of tangible personal property made by Vendor/Contractors who use the tangible personal property in the performance of contracts for improvements of County owned real property (Chapters 192 and 212, F.S. and applicable rules of the Department of Revenue).
- C. State sales tax and use taxes on materials and equipment are to be incorporated in the price bid.
- D. Vendor/Contractor shall pay all sales, consumer, use, and other similar taxes required to be paid by Vendor/Contractor in accordance with the laws and regulations of the place of the project which are applicable during the performance of the work.

### 5.14. MANUFACTURERS' NAME AND APPROVED EQUIVALENTS:

Whenever a particular brand or make of material, equipment, or other item is specified, or is indicated on the drawings, it is for the purpose of establishing a standard of quality, design, and type desired and to supplement the detailed specifications. Any other brand or make which is equivalent to that specified or indicated may be offered as an equivalent prior to the Solicitation Question Submission Deadline, for review and approval by Hernando County subject to the following provisions:

- A. The Vendor/Contractor shall submit for each proposed equivalent sufficient details, complete descriptive literature, and performance data together with samples of the materials, where feasible, to enable the Engineer of Record to determine if the proposed equivalent is equal, in all respects including, but not limited to, quality, performance, ease of maintenance, availability of spare parts, and experience record.
- B. The Vendor/Contractor shall submit certified tests, where applicable, by an independent laboratory attesting that the proposed equivalent is equal.
- C. A list of installations where the proposed equivalent is used. Such listing shall cover a minimum of the previous three (3) years and will furnish project names and contact phone numbers.
- D. Where the acceptance of an equivalent requires excessive review by the Engineer of Record, revision or redesign of any part of the work, all such additional review costs, revisions and redesign, and all new drawings and details required therefore, shall be at the Vendor/Contractor's expense.

- E. The Engineer of Record and Hernando County will have sole discretion to accept or deny any proposed equivalent.
- F. Acceptance of any proposed equivalent shall in no way release the Vendor/Contractor from any of the provisions of the Contract Documents.
- G. Hernando County may require, at Vendor/Contractor's expense, a special performance guarantee or other surety with respect to any equivalent.
- H. Bids which do not comply with these requirements are subject to rejection.

#### 5.15. BID EVALUATION AND AWARD:

- A. The County requires that, at the time of submitting its bid response, the Bidder be properly licensed and registered to do business in the State of Florida in accordance with applicable Florida Statutes. Bid responses that fail to provide the required forms listed in [Vendor Questionnaire](#) may be rejected as non-responsive. Bidders whose responses, past performance, or current status do not reflect the capability, integrity or reliability to fully and in good faith perform the requirements of the bid may be rejected as non-responsible. The County reserves the right to determine which responses meet the requirements of this Solicitation, and which Bidders are responsive and responsible. The County reserves the right before awarding the bid, to require a Bidder to submit such evidence of their qualifications as it may deem necessary, and may consider any evidence available to it of the financial, technical, and other qualifications and abilities of a Bidder to perform the work in a satisfactory manner and within the time specified. The Bidder is assumed to be familiar with all Federal, State or local laws, ordinances, rules and regulations that in any manner affect the work, and to abide thereby if awarded the bid. Ignorance of legal requirements on the part of the Bidder will in no way relieve responsibility.
- B. Bid evaluation will be based on price, conformance with specifications and the Bidder's ability to perform the Contract in accordance with the terms and conditions required. Bidders must submit all data necessary to evaluate and determine the quality of the item(s) and/or services they are bidding.
- C. The County intends to award this Contract to the lowest, responsive and responsible Bidder or Bidders. However, the County reserves the right to reject any and all bids in accordance with the Hernando County Procurement Ordinance.
- D. The ability of a Bidder to obtain a performance and payment bond shall not be regarded as the sole test of such Bidder's competency or responsibility.
- E. Nothing contained herein shall place a duty upon the Hernando County Board of County Commissioners to reject bids or award a contract based upon anything other than its sole discretion as described herein.

- F. Bidders are not permitted to submit more than one (1) bid for this project. Reasonable grounds for believing that any Bidder has an interest in more than one (1) bid for this project may be cause for disqualification of that Bidder and the rejection of all bids in which that Bidder has an interest.
- G. Owner will consider whether or not the bids comply with the prescribed requirements, and such alternates, unit prices and other data, as may be requested in the Bid Form or prior to the Notice of Award.
- H. Owner will consider the qualifications of Bidders and may consider the qualifications and experience of subcontractors, suppliers, and other individuals or entities proposed for those portions of the work for which the identity of subcontractors, suppliers, and other individuals or entities must be submitted.
- I. The County reserves the right to investigate the competency and financial ability of any Bidder, proposed subcontractors, suppliers, or individuals that will perform the work; and, if after investigation, the evidence of competency or financial ability is not satisfactory, the County reserves the right to reject the bid.
- J. If two (2) or more fully responsive, responsible bids are received for the same total amount or unit price, quality and service being equal, the County reserves the right to award the contract to the Bidder whose place of business is located within the boundaries of Hernando County, Florida. Should tie bids, as described above, be received from either two (2) or more Hernando County Bidders or from non-local Bidders when no Hernando County Bidder has submitted a tie bid, then the Board of County Commissioners shall award the contract to one (1) Vendor/Contractor by drawing lots in a public meeting.
- K. Bidders/Proposers are hereby notified of the provisions of section 287.05701, Florida Statutes, as amended, that the County or the County's Board will not request documentation of or consider a Bidder's/Proposer's social, political, or ideological interests when determining if the Bidder/Proposer is responsible and may not give preference to a Bidder/Proposer based on the Bidder's/Proposer's social, political, or ideological interests.
- L. If the County intends to reject all bids based on price the County may, before posting a notice of intent to reject all bids, provide to the lowest responsive, responsible bidder the opportunity to negotiate the scope of work with a corresponding reduction in price. Upon reaching a decision regarding the lowest bidder's reduced bid, the County will post notice of final agency action to either reject all bids or accept the reduced bid. This subsection does not prohibit the filing of a protest by any bidder or alter the deadlines provided for filing a protest. Upon receipt of a formal written protest that is timely filed, the County may continue the process provided in this subsection but may not take final agency action as to the lowest bidder except as part of the County's final agency action in the protest or upon dismissal of the protest by the protesting party.

## 5.16. LOCAL PREFERENCE:

- A. Purpose and Findings: These provisions apply to purchases using Formal Bid, Request for Proposals or Quotes. The County annually spends significant dollars on purchasing personal property, materials, and services, and in constructing improvements to real property or existing structures. The dollars used in making those purchases are derived, in large part, from taxes, fees and utility revenues paid by businesses located within Hernando County, and the County Commission has determined that funds generated in the community should, to the extent possible, be placed back into the local economy. Therefore, the County Commission has determined that it is in the best interest of the County to give a preference to local businesses in making such purchases whenever the application of such a preference is reasonable in light of the dollar-value of bids and quotes received in relation to such expenditures.
- B. Application:
1. In bidding for, or letting contracts for procurement of supplies, materials, equipment, and services, as described in the procurement policies of the County, the Board of County Commissioners may give a preference to local businesses in making purchases or awarding contracts in an amount not to exceed:
    - a. Five percent (5%) of the local business' total bid price if the cost differential does not exceed \$10,000.00 for procurement activities in amounts over \$50,000.00.
- C. Definitions:
1. Local vendor means a person or business entity which has maintained a permanent place of business with full-time employees within Hernando County for a minimum of twelve (12) months prior to the date bids or quotes were received for the purchase or contract at issue, and which generally provides from such permanent place of business the kinds of goods or services solicited, and which at the time of the Solicitation fully complies with the local vendor eligibility identified in Paragraph 2 below.
  2. Local Vendor Affidavit of Eligibility shall accompany the quotation or bid submittal in order to be considered valid and shall include, but not be limited to, the following current information:
    - a. A physical business and location address;
    - b. Proof of payment of real property tax due to Hernando County
    - c. A copy of the firm's most recent annual corporation report to the Florida Division of Corporations;
    - d. Any additional information necessary to verify local status.
- D. Competitive Bids/Quotes: The County reserves the exclusive right to compare, contrast and otherwise evaluate the qualifications, character, responsibility and financial qualifications of all

persons, firms, partnerships, companies or corporations submitting formal bids or formal quotes in any procurement for goods and services when making an award in the best interests of the County.

E. Exemptions:

1. Purchases resulting from exigent emergency conditions where any delay in completion or performance would jeopardize public health, safety, or welfare of the citizens of the County, or where in the judgment of the County the operational effectiveness or a significant County function would be seriously threatened if a purchase was not made expeditiously.
2. Purchases with any sole source supplier for supplies, materials, or other equipment.
3. Purchases made through cooperative purchasing arrangements utilized by the Procurement Department as identified in the Procurement Policy.
4. Purchases that are funded in whole or in part by assistance from any Federal, State, or local agency where the program guidelines do not permit local preference.
5. Purchases with an estimated cost of less than \$10,000.00 or less.

- F. Appeal: If an application for a “Local Vendor/Contractor” designation is denied, the applicant may appeal such decision to the County Administrator for review and further consideration.

### 5.17. QUALIFICATIONS OF SURETY COMPANIES

In order to be acceptable to the Owner, a surety company issuing bid guaranty bonds, or 100% Performance/Payment Bonds, called for in these Contract Documents, shall meet and comply with the following minimum standards:

- A. Surety must be admitted to do business in the State of Florida and shall comply with the provisions of Florida Statute 255.05.
- B. Surety companies executing bonds must appear on the United States Treasury Departments most current list (CIRCULAR 570 AS AMENDED).
- C. Attorneys-in-fact who sign Bid Bonds or Performance/Payment Bonds must file with such bond a certified copy of their power of attorney to sign such bond.
- D. Agents of surety companies must list their name, address and telephone number on all bonds.
- E. If the surety on any bond furnished by the successful Bidder is declared bankrupt or becomes insolvent or its right to do business is terminated in any state where any part of the project is located or it ceases to meet the requirements provided in this paragraph, Bidder (Vendor/Contractor) shall within five (5) days thereafter, substitute another bond and surety, both of which must be acceptable to the County.

### 5.18. LITIGATION/WAIVER OF JURY TRIAL

This Agreement shall be governed by and construed according to Florida law. Venue for any dispute or formal litigation concerning this Agreement shall be in the appropriate court with territorial jurisdiction over Hernando County, Florida. In the event of a dispute or litigation, each party to such dispute or litigation shall be solely responsible for its own attorneys' fees and costs. This Agreement shall not be construed for or against any party hereto, regardless of which party is wholly or partly responsible for its drafting. Each party acknowledges that it is aware of and has had the opportunity to seek advice of counsel of its choice with respect to its rights to trial by jury, and each party, for itself and its successors, creditors, and assigns, does hereby expressly and knowingly waive and release all such rights to trial by jury in any action, proceeding or counterclaim brought by any party hereto against the other (and/or against its officers, directors, employees, agents, or subsidiary or affiliated entities) on or with regard to any matters whatsoever arising out of or in any way connected with this Contract and/or any other claim of injury or damage.

### 5.19. MAINTENANCE OF RECORDS

The Vendor/Contractor will keep adequate records and supporting documents applicable to this Contract. Said records and documentation will be retained by the Vendor/Contractor for a minimum of five (5) years from the date of final payment on this Contract. The County and its authorized agents shall have the right to audit, inspect and copy records and documentation as often as the County deems necessary during the period of this Contract and a period of five (5) years after completion of contract performance; provided however, such activity shall be conducted only during normal business hours. The County during the period of time defined by the preceding sentence, shall also have the right to obtain a copy of and otherwise inspect any audit made at the direction of the Vendor/Contractor as concerns the aforesaid records and documentation. Pursuant to Section 119.0701, Florida Statutes, Consultant/Firm shall comply with the Florida Public Records' laws and shall:

- A. Keep and maintain records that ordinarily and necessarily would be required by the public agency in order to perform the service;
- B. Provide the public with access to public records on the same terms and conditions that the public agency would provide the records and at a cost that does not exceed the cost provided in Chapter 119, F.S., or as otherwise provided by law.
- C. Ensure that public records that are exempt or confidential and exempt from public records disclosure requirement are not disclosed except as authorized by law; and,
- D. Meet all requirements for retaining public records and transfer, at no cost, to the public agency all public records in possession of the Consultant/Firm upon termination of the Contract and destroy any duplicate public records that are exempt or confidential and exempt from public records disclosure requirements. All records stored electronically must be provided to the public agency in a format that is compatible with the information technology systems of the public agency.

- E. Failure to comply with this section shall be deemed a breach of the Contract and enforceable as set forth in Section 119.0701, Florida Statutes.

**IF THE CONTRACTOR HAS QUESTIONS REGARDING THE APPLICATION OF CHAPTER 119, FLORIDA STATUTES, TO THE CONTRACTOR'S DUTY TO PROVIDE PUBLIC RECORDS RELATING TO THIS CONTRACT, CONTACT THE CUSTODIAN OF PUBLIC RECORDS AT 352-754-4020, PURCHASING@HERNANDOCOUNTY.US, WITH AN OFFICE LOCATED AT 15470 FLIGHT PATH DR., BROOKSVILLE, FL 34604.**

Per sec. Florida Statute 20.055(5), it is the duty of every State officer, employee, agency, special district, board, commission, Contractor, and subcontractor to cooperate with the Inspector General in any investigation, audit, inspection, review, or hearing pursuant to this section.

#### 5.20. FISCAL NON-FUNDING:

In the event sufficient budgeted funds are not available for a new fiscal period, the County must notify the Vendor/Contractor of such occurrence and Contract shall terminate on the last day of current fiscal period without penalty or expense to the County.

#### 5.21. CONFLICT OF INTEREST

- A. Conflict of Interest of Officers or Employees of the Contracting Entity/Local Jurisdiction, Members of the Local Governing Body, or Other Elected Officials: No member or employee of the contracting entity/local jurisdiction or its designees or agents; no member of the governing body; and no other public official of Hernando County who exercises any function or responsibility with respect to this Contract, during his/her tenure or for one (1) year thereafter, shall have any interest, direct or indirect, in any contract or subcontract, or the proceeds thereof, for work to be performed. Further, the Vendor/Contractor shall cause to be incorporated in all Sub-contracts, the language set forth in this paragraph prohibiting conflict of interest.
- B. Employee Conflict of Interest: It shall be unethical for any Hernando County employee to participate directly or indirectly in a procurement contract when Hernando County employee knows that:
  - 1. Hernando County employee or any member of Hernando County employee's immediate family has a financial interest in the procurement contract; or
  - 2. Any other person, business, or organization with whom Hernando County employee or any member of a Hernando County employee's immediate family is negotiating or has an arrangement concerning prospective employment is involved in the procurement contract.
- C. A Hernando County employee or any member of a Hernando County employee's immediate family who holds a financial interest in a disclosed blind trust shall not be deemed to have a conflict of interest with regard to matters pertaining to that financial interest.

- D. **Former Employee Conflict of Interest:** It shall be a violation for any person, business or organization contracting with County to employ in any capacity, any former County employee or member of County employee's immediate family within one (1) year of that employee's separation from employment with the County, unless the employer or the former County employee files with this solicitation, the County's Employment Disclosure Statement. The penalty for this violation may include disqualification of the bid submission.

## 5.22. **GRATUITIES AND KICKBACKS:**

- A. **Gratuities:** It shall be unethical for any person to offer, give, or agree to give any Hernando County employee or former Hernando County employee, or for any Hernando County employee or former Hernando County employee to solicit, demand, accept, or agree to accept from another person, a gratuity or an offer of employment in connection with any decision, approval, disapproval, recommendation, or preparation of any part of a program requirement or a purchase request, or to influence the content of any specification or procurement standard, or to act in an render advisory, investigative or auditing capacity. The County in any proceeding or application, request for ruling, determination, claim or controversy, or other particular matter, pertaining to any program requirement or a contract or sub-contract, or to any solicitation or proposal therefor, shall not accept any gratuities.
- B. **Kickbacks:** It shall be unethical for any payment, gratuity, or offer of employment to be made by or on behalf of a Sub-Contractor under a contract to the prime Vendor/Contractor or higher tier Sub-Contractor or any person associated therewith, as an inducement for the award of a Sub-Contract or order.

## 5.23. **E-VERIFY**

- A. Vendor/Contractor is advised that the County has entered into an agreement with U.S. Immigration and Customs Enforcement (ICE) wherein the County will, in part, seek to promote the principles of ethical business conduct, prevent the knowing hiring of unauthorized workers through self-governance, and encourage voluntary reporting of the discovery of unauthorized workers to ICE (the IMAGE Agreement). Accordingly, by submitting your bid/proposal, Vendor/Contractor represents and warrants (a) that the Vendor/Contractor is in compliance with all applicable Federal, State and local laws, including, but not limited to, the laws related to the requirement of an employer to verify an employee's eligibility to work in the United States, (b) that all of the Vendor/Contractor employees are legally eligible to work in the United States, and (c) that the Vendor/Contractor has actively and affirmatively verified such eligibility utilizing the Federal Government's Employment Verification Eligibility Form (I-9 Form).
- B. A mere allegation of Vendor/Contractor's intent to use and/or current use of unauthorized workers may not be a basis to delay the County's award of a contract to the Vendor/Contractor

unless such an allegation has been determined to be factual by ICE pursuant to an investigation conducted by ICE prior to the date the contract is scheduled to be awarded by the County.

C. Legitimate claims of the Vendor/Contractor's use of unauthorized workers must be reported to both of the following agencies:

1. The County's Procurement Department at (352) 754-4020: and
2. ICE (Immigration and Customs Enforcement) at 1-866-DHS-2-ICE.

D. In the event it is discovered that the Vendor/Contractor's employees are not legally eligible to work in the United States, then the County may, in its sole discretion, demand that the Vendor/Contractor cure this deficiency within a specified time frame, and/or immediately terminate the Contract without any cost or penalty to the County, and/or debar the Vendor/Contractor from bidding on all County contracts for a period up to twenty-four (24) months, and/or take any and all legal action deemed necessary and appropriate.

E. Vendor/Contractor is required to incorporate the following IMAGE Best Practices into its business and, when practicable, incorporate verification requirements into its agreements with subcontractors:

1. Use the Department of Homeland Security employment eligibility verification program (E-Verify) to verify the employment eligibility of all new hires.
2. Use the Social Security Number Verification Service and make good faith effort to correct and verify the names and Social Security Numbers of the current workforce.
3. Establish a written hiring and employment eligibility verification policy.
4. Establish an internal compliance and training program related to the hiring and employment verification process, to include, but not limited to, completion of Form I-9, how to detect fraudulent use of documents in the verification process, and how to use E-Verify and the Social Security Number Verification Service.
5. Require the Form I-9 and E-Verify process to be conducted only by individuals who received appropriate training and include secondary review as of each employee's verification to minimize the potential for a single individual to subvert the process.
6. Arrange for annual Form I-9 audits by an external auditing firm or a trained employee not otherwise involved in the Form I-9 process.
7. Establish a procedure to report to ICE credible information of suspected criminal misconduct in the employment eligibility verification process.
8. Establish a program to assess subcontractors' compliance with employment eligibility verification requirements. Encourage Vendor/Contractors to incorporate the IMAGE Best

Practices contained in this paragraph and, when practicable, incorporate the verification requirements in subcontractor agreements.

9. Establish a protocol for responding to letters received from Federal and State government agencies indicating that there is a discrepancy between the agency's information and the information provided by the employer or employee; for example, "no match" letters received from the Social Security Administration.
10. Establish a tip line mechanism (inbox, e-mail, etc.) for employees to report activity relating to the employment of unauthorized workers, and a protocol for responding to employee tips.
11. Establish and maintain appropriate policies, practices, and safeguards against use of the verification process for unlawful discrimination, and to ensure that U.S. citizens and authorized workers do not face discrimination with respect to hiring, firing, recruitment or referral for a fee because of citizenship status or national origin.
12. Maintain copies of any documents accepted as proof of identify and/or employment authorization for all new hires.

#### 5.24. INSURANCE REQUIREMENTS

##### A. INDEMNITY, SAFETY AND INSURANCE PROVISIONS:

1. Indemnity: To the fullest extent permitted by Florida law, the Vendor/Contractor covenants, and agrees that it will indemnify and hold harmless the County and all of the County's officers, agents, and employees from any claim, loss, damage, cost, charge, attorney's fees and costs, or any other expense arising out of any act, action, neglect, or omission by Vendor/Contractor during the performance of the contract, whether direct or indirect, and whether to any person or property to which the County or said parties may be subject, except that neither the Vendor/Contractor nor any of its subcontractors, or assignees, will be liable under this section for damages arising out of injury or damage to persons or property directly caused or resulting from the sole negligence of the County or any of its officers, agents, or employees.
2. Protection of Person and Property:
  - a. The Vendor/Contractor will take all reasonable precautions for, and will be responsible for initiating, maintaining and supervising all programs relating to the safety of all persons and property affected by, or involved in, the performance of his operations under this Contract.
  - b. The Vendor/Contractor will take all reasonable precautions to prevent damage, injury or loss to: (a) all persons who may be affected by the performance of his operations, including employees; (b) all materials and equipment; and (c) all property at or

surrounding the work site. In an emergency affecting the safety of persons or property, the Vendor/Contractor will act, with reasonable care and discretion, to prevent any threatened damage, injury or loss.

B. MINIMUM INSURANCE REQUIREMENTS: Vendor/Contractor shall procure, pay for and maintain at least the following insurance coverage and limits. Said insurance shall be evidenced by delivery to the County of a certificate(s) of insurance executed by the insurers listing coverage and limits, expiration dates and terms of policies and all endorsements whether or not required by the County, and listing all carriers issuing said policies. The insurance requirements shall remain in effect throughout the term of this Contract.

1. Workers' Compensation: As required by law:

a. State.....Statutory

b. APPLICABLE FEDERAL.....Statutory

c. EMPLOYER'S LIABILITY.....Minimum:

i. \$100,000.00 each accident

ii. \$100,000.00 by employee

iii. \$500,000.00 policy limit

d. Exemption per Florida Statute 440: If a Vendor/Contractor has less than three (3) employees and states that they are exempt per Florida Statute 440, they must provide an exemption certificate from the State of Florida. Otherwise, they will be required to purchase Workers' Compensation Insurance and provide a copy of Workers Compensation Insurance.

<https://www.myfloridacfo.com/Division/WC/Employer/Exemptions/>

2. General Liability: Comprehensive General Liability including, but not limited to, Independent Contractor, Contractual Premises/Operations, and Personal Injury covering the liability assumed under indemnification provisions of this Contract, with limits of liability for personal injury and/or bodily injury, including death.

a. Coverage as follows:

i. EACH OCCURRENCE.....\$1,000,000.00

ii. GENERAL AGGREGATE .....\$2,000,000.00

iii. PERSONAL/ADVERTISING INJURY.....\$1,000,000.00

iv. PRODUCTS-COMPLETED OPERATIONS AGGREGATE.....\$2,000,000.00 Per Project Aggregate (if applicable)

- b. ALSO, include in General Liability coverage for the following areas based on limits of policy, with:
  - i. FIRE DAMAGE (Any one (1) fire).....\$50,000.00
  - ii. MEDICAL EXPENSE (Any one (1) person)..... \$5,000.00
- 3. Additional Insured: Vendor/Contractor agrees to endorse Hernando County as an additional insured on the Comprehensive General Liability. The Additional Insured shall read "Hernando County Board of County Commissioners." Proof of Endorsement is required.
- 4. Waiver of Subrogation: Vendor/Contractor agrees by entering into this Contract to a Waiver of Subrogation for each required policy herein. When required by the insurer, or should a policy condition not permit Vendor/Contractor to enter into a pre-loss agreement to waive subrogation without an endorsement, then Vendor/Contractor agrees to notify the insurer and request the policy be endorsed with a Waiver of Transfer of Rights of Recovery Against Others, or its equivalent. This Waiver of Subrogation requirement shall not apply to any policy, which includes a condition specifically prohibiting such an endorsement, or voids coverage should Vendor/Contractor enter into such an agreement on a pre-loss basis.
- 5. AUTOMOBILE LIABILITY: Comprehensive automobile and truck liability covering any auto, all owned autos, scheduled autos, hired autos, and non-owned autos. Coverage shall be on an "occurrence" basis. Such insurance to include coverage for loading and unloading hazards. Coverage as follows:
  - a. COMBINED SINGLE LIMIT (CSL)..... \$1,000,000.00 or:
    - i. BODILY INJURY (Per Person)..... \$1,000,000.00
    - ii. BODILY INJURY (Per Accident)..... \$1,000,000.00
    - iii. PROPERTY DAMAGE.....\$1,000,000.00
- 6. PROFESSIONAL LIABILITY (if applicable it will be noted below separately):
- 7. BUILDERS RISK INSURANCE (if applicable it will be noted below separately):
- 8. CRIME PREVENTION – BOND (if applicable it will be noted below separately):
- 9. EXCESS/UMBRELLA LIABILITY (if applicable it will be noted below separately):
- 10. POLLUTION LIABILITY (if applicable it will be noted below separately):
- 11. SUBCONTRACTORS (if applicable): All subcontractors hired by said Contractor are required to provide Hernando County Board of County Commissioners a Certificate of Insurance with the same limits required by the County as required by the Contract. All subcontractors are required to name Hernando County Board of County Commissioners as additional insured and provide a Waiver of Subrogation in regards to General Liability.

12. RIGHT TO REVISE OR REJECT: County reserves the right, but not the obligation, to revise any insurance requirement, not limited to limits, coverages and endorsements, or to reject any insurance policies which fail to meet the criteria stated herein. Additionally, County reserves the right, but not the obligation, to review and reject any insurer providing coverage due of its poor financial condition or failure to operating legally.
- C. EACH INSURANCE POLICY SHALL INCLUDE THE FOLLOWING CONDITIONS BY ENDORSEMENT TO THE POLICY:
1. Vendor/Contractor agrees to provide County with a Certificate of Insurance evidencing that all coverages, limits and endorsements required herein are maintained and in full force and effect, and the Certificate of Insurance shall provide a minimum thirty (30) day endeavor to notify, when available by Vendor/Contractor's insurer. If the Vendor/Contractor receives a non-renewal or cancellation notice from an insurance carrier affording coverage required herein, or receives noticed that coverage no longer complies with the insurance requirements herein, Vendor/Contractor agrees to notify the County by email within five (5) business days with a copy of the non-renewal or cancellation notice, or written specifics as to which coverage is no longer in compliance. The Certificate Holder shall read: **Hernando County Board of County Commissioners Attention: Human Resources/Risk Department 15470 Flight Path Drive, Brooksville, Florida 34604**
  2. Companies issuing the insurance policy, or policies, shall have no recourse against the County for payment of premiums or assessments for any deductibles which all are the sole responsibility and risk of Vendor/Contractor.
  3. The term "County" or "Hernando County" shall include all authorities, boards, bureaus, commissions, divisions, departments, and offices of the County and individual members, employees and agents thereof in their official capacities, and/or while acting on behalf of Hernando County.
  4. The policy clause "Other Insurance" shall not apply to any insurance coverage currently held by County, to any such future coverage, or to County's Self-Insured Retentions of whatever nature.
- D. The Vendor/Contractor shall be required to provide a current Certificate of Insurance to the County prior to commencement of services.
- E. Bidders may, at the County's request, be required to provide proof that their firm meets the preceding insurance requirements, by submission of a Certificate Of Insurance coverage(s), prior to award of the Contract.
- F. Failure of the Owner to demand such certificates or other evidence of full compliance with these insurance requirements or failure of the Owner to identify a deficiency from evidence provided shall not be construed as a waiver of Vendor/Contractor's obligation to maintain such insurance.

### 5.25. INSURANCE REQUIREMENTS (continued)

**BUILDERS RISK INSURANCE:** Combined single limit must equal value of the construction, per project aggregate. The policy shall cover portions of the work in transit, property scaffolding, false work and temporary buildings located at the site. The policy must cover the cost of removing debris, including demolition as may be made legally necessary by the operation of any law, ordinance or regulation. The insurance required herein must be on an All Risk Form and must be written to cover all risks of physical loss or damage to the insured party and must insure at least against the perils of fire and extended coverage, theft, vandalism, malicious mischief, collapse, lightning, earthquake, flood, water damage and windstorm. If there are any deductibles applicable to the insurance required herein, Vendor/Contractor must pay any part of any loss not covered because of the operation of such deductibles. The insurance as required herein must be maintained in effect until the earliest of the following date:

- A. Date which all persons and organization that are insured under the policy agree in writing that it must be terminated;
- B. Date on which final payment of this Contract has been made by County to Vendor/Contractor;  
or
- C. Date on which the insurable interests in the property of all insured other the County have ceased.
- D. Wind coverage to be included with a minimum deductible to be determined based on the project. Deductible will be a percentage based upon the total insured value.

### 5.26. INSURANCE REQUIREMENTS (continued)

**EXCESS/UMBRELLA LIABILITY:** Vendor/Contractor shall provide proof of Excess/Umbrella Liability coverage with minimum limits of \$1,000,000.00. Limits can be increased, based on Contract.

### 5.27. EXECUTION OF WRITTEN CONTRACT

The successful Bidder will be required to sign a written contract, in two (2) copies, which has been made a part of this bid package and identified as the Sample Construction Agreement in Questionnaire. Said written Contract will evidence in written form the agreement between the parties pursuant to the award having been therefore made by the County to this Bidder; said signing to be accomplished within ten (10) days after Notice of Award.

### 5.28. CONE OF SILENCE

- A. This Solicitation falls under the Hernando County Procurement Ordinance 93-16. All Vendors and Bidders, and representatives of same, are hereby placed on formal notice that a lobbying cone of silence period shall commence upon issuance of this Solicitation until the Board selects the successful Bidder. If Board is not involved in selecting the successful Bidder, the cone of silence period commences upon issuance of Solicitation and concludes upon award of Contract. During the cone of silence period, no Vendor/Bidder, or representative of the Vendor/Bidder, to

this Solicitation may seek information or clarification or in any way contact any official or employee of the County concerning this Solicitation with the exception of the Chief Procurement Officer, County Attorney, or an individual specifically designated in this document for dissemination of information. A copy of any written communication concerning this Solicitation shall be filed with the Procurement Department and shall be made available to the public upon request. A violation of the cone of silence renders any award voidable at the discretion of the Chief Procurement Officer with approval from the Board and may subject the Vendor/Bidder who violated it to debarment. Nothing in the Ordinance prevents a Vendor/Bidder or representative from taking part in a public meeting concerning the Solicitation. B. Neither the members of the Board nor candidates for County Commission, nor any employees from the Hernando County Government, Hernando County staff members, nor any members of the evaluation team are to be lobbied, either individually or collectively, before or during the cone of silence concerning this project. Vendors/Bidders, or representatives of same, who intend to submit bids, or have submitted bids, for this project are hereby placed on formal notice that they are not to contact County personnel for such purposes as holding meetings of introduction, meals, or meetings relating to the selection process outside of those specifically scheduled by the County. Any such lobbying activities may cause immediate disqualification of this project.

#### 5.29. OWNER DIRECT PURCHASE:

The County reserves the right to directly purchase certain materials, supplies, and goods, or to require Vendor/Contractor to assign some or all of its Sub-contractors or other Agreements with material suppliers, including equipment, directly to the County. Any materials purchased by the County pursuant to such Agreements or assignments will be referred to as "Owner Direct Purchases" (ODP) and is a method that may be utilized to create saving for the County. The responsibilities of both the County and the Vendor/Contractor relating to such ODP will be governed by the terms and conditions of these Owner Direct Purchase Conditions, which will take precedence over other conditions and terms of the Contract Documents where inconsistencies or conflicts exist. Owner Direct Purchases shall be made in accordance with Florida Administrative Code Rule 12A-1.094.

- A. Material suppliers shall be selected by Vendor/Contractor using competitive bidding/proposals. Supply Contracts shall be awarded by the Vendor/Contractor to the supplier whose Bid/Proposal is most advantageous to the County, price and other factors considered.
- B. The Vendor/Contractor shall include the price for all construction materials in lump sum price in bid. Bidder shall also include all Florida State sales and other taxes normally applicable to such material and equipment. The County may consider purchasing any item but does not expect to issue purchase orders for less than \$5,000. County-Purchasing of selected construction materials will be administered on a deductive Change Order basis.

- C. Vendor/Contractor shall provide County a list of all intended suppliers, vendors, and material men for consideration as ODP. This list shall be submitted at the same time as the preliminary schedule of values and the project CPM schedule. The Vendor/Contractor shall submit price quotes from the vendors, as well as a description of the materials to be supplied, estimated quantities and prices.
- D. Upon request from County, and in a timely manner, Vendor/Contractor shall prepare a Purchasing Requisition Request Form which shall, in form and detail acceptable to County, specifically identify the materials which County may, in its discretion, elect to purchase directly. The Purchasing Requisition Request Form shall include:
1. the name, address, telephone number and contact person for the material supplier
  2. manufacturer or brand, model or specification number of the item
  3. quantity needed as estimated by Vendor/Contractor
  4. the price quoted by the supplier for the materials identified therein
  5. any sales tax associated with such quote
  6. delivery dates as established by Vendor/Contractor
  7. any reduction in Vendor/Contractor's cost for both the Payment Bond and the Performance Bond
  8. shipping, handling and insurance costs
  9. detail concerning bonds or letters of credit provided by the supplier if included in his/her proposal
  10. Special terms and conditions which have been negotiated with the supplier relative to payment terms, discounts, rebates, warranty, credits or other terms and conditions which will revert to the Owner.
  11. Vendor/Contractor shall include copies of Vendor/Contractor's quotations and specifically reference any terms and conditions, which have been negotiated with the Vendor/Contractor concerning letters of credit, terms, discounts, or special payments.
- E. After receipt of the Purchasing Requisition Request Form, County shall prepare a Purchase Order for all items of material, which County chooses to purchase directly. The purchase order shall be sent to the Vendor/Contractor with a copy sent to the Vendor/Contractor. Pursuant to the Purchase Order, the Vendor/Contractor will provide the required quantities of material at the price established in the Vendor/Contractor's quote to the Vendor/Contractor, excluding any sales tax associated with such price. The Project Manager shall be the approving authority for the County on Purchase Orders in conjunction with ODP. The Purchase Order shall also require

the delivery of the ODP on the delivery dates provided by the Vendor/Contractor in the Purchasing Requisition Request Form.

- F. In conjunction with the execution of the Purchase Orders by the suppliers, Vendor/Contractor shall execute and deliver to County one or more deductive Change Orders, referencing the full value of all ODP to be provided by each supplier from whom the County elected to purchase material directly, plus all sales taxes associated with such materials in Vendor/Contractor's bid to County, plus any savings to Vendor/Contractor in the cost of Payment and Performance Bonds associated with such ODP. To compensate the Vendor/Contractor for the warranty enforcement obligation the Vendor/Contractor's overhead and profit associated with ODP shall not be deducted from the Contract. The Project Manager shall be the approving authority for the County on deductive Change Orders in conjunction with ODP.
- G. Vendor/Contractor shall be fully responsible for all matters relating to the procurement of materials furnished by and incorporated into the Project in accordance with these Supplementary Conditions including, but not limited to, assuring the correct quantities, placing the order in a timely manner, and assuring coordination of purchases, providing and obtaining all warranties and guarantees required by the Contract Documents, inspection and acceptance of the goods at the time of delivery. The Vendor/Contractor shall coordinate delivery schedules, sequence of delivery, loading orientation, and other arrangements normally required by the Vendor/Contractor for the particular materials furnished. The Vendor/Contractor shall provide all services required for the unloading, handling and storage of materials through installation. The County assumes the risk of loss of building material through their incorporation into the installation.
- H. As ODP are delivered to the jobsite, the Vendor/Contractor shall visually inspect all shipments from the suppliers, and sign off on the receiving reports for material delivered. The Vendor/Contractor shall assure that each delivery of ODP is accompanied by documentation adequate to identify the Purchase Order against which the purchase is made. This documentation may consist of a delivery ticket and an invoice from the supplier conforming to the Purchase Order together with such additional information as the County may require. The Vendor/Contractor will then forward the receiving report to the County Project Manager to match up with the invoice for payment.
- I. The Vendor/Contractor shall insure that ODP conform to the Specifications, and determine prior to incorporation into the Work if such materials are patently defective, and whether such materials are identical to the materials ordered and match the description on the bill of lading. If the Vendor/Contractor discovers defective or non-conformities in ODP upon such visual inspection, the Vendor/Contractor shall not utilize such nonconforming or defective materials in the Work and instead shall promptly notify the County of the defective or nonconforming condition so that repair or replacement of those materials can occur without any undue delay or interruption to the Project. If the Vendor/Contractor fails to perform such inspection and

otherwise incorporates into the work such defective or nonconforming ODP, the condition of which it either knew or should have known by performance of an inspection, Vendor/Contractor shall be responsible for all damages to County resulting from Vendor/Contractor's incorporation of such materials into the Project, including liquidated or delay damages.

- J. The Vendor/Contractor shall maintain records of all ODP it incorporates into the Work from the stock of ODP in its possession. The Vendor/Contractor shall account monthly to the County for any ODP delivered into the Vendor/Contractor's possession, indicating portions of all such materials which have been incorporated into the work.
- K. The Vendor/Contractor shall be responsible for obtaining and managing all warranties and guarantees for all materials and products as required by the Contract Documents. All repair, maintenance or damage-repair calls shall be forwarded to the Vendor/Contractor for resolution with the appropriate supplier, vendor, or Sub-contractor. Additionally, ODP items shall be warranted by the Vendor/Contractor as part of the Vendor/Contractor's warranty. The Vendor/Contractor agrees and understands that it shall undertake all warranty enforcement and other related duties of the County for its Owner Direct Purchase equipment and materials. These duties shall be governed by and carried out pursuant to, Bid Specifications. To that end, the Vendor/Contractor expressly agrees it shall make no distinction in discharging such warranty duties between Owner Direct Purchase equipment and materials and equipment and materials otherwise supplied by the Vendor/Contractor.
- L. Notwithstanding the transfer of ODP by the County to the Vendor/Contractor's possession, the County shall retain legal and equitable title to any and all ODP.
- M. The transfer of possession of ODP from the County to the Vendor/Contractor shall constitute a bailment for the mutual benefit of the County and the Vendor/Contractor. The County shall be considered the bailor and the Vendor/Contractor the bailee of the ODP. ODP shall be considered returned to the County for purposes of their bailment at such time as they are incorporated into the Project.
- N. The County shall purchase and maintain builders risk insurance sufficient to protect against any loss of or damage to ODP. Such insurance shall cover the full value of any ODP not yet incorporated into the Project during the period between the time the County first takes title to any of such ODP and the time when the last of such is incorporated into the Project. The Vendor/Contractor shall purchase and maintain builders' risk, all risk, insurance based on the completed value of project, less the County's ODP values. The Vendor/Contractor must name Hernando County as additional insured on its policy.
- O. The County shall in no way be liable for any interruption or delay in the Project, for any defects or other problems with the Project, or for any extra costs resulting from any delay in the delivery of, or defects in, ODP. Vendor/Contractor's sole or exclusive remedy shall be an extension of the Contract Time for such reasonable time as determined by Project Manager.

- P. Vendor/Contractor shall be required to review invoices submitted by all suppliers of ODP delivered to the project sites and either concur or object to the County's issuance of payment to the suppliers, based upon Vendor/Contractor's records of materials delivered to the site and any defects detected in such materials.
- Q. In order to arrange for the prompt payment to the supplier, prompt submittal of a copy of the applicable Purchase Order as receiving report, invoices, delivery tickets, written acceptance of the delivered items, and such other documentation as may be reasonably required by the County. Upon receipt of the appropriate documentation, the County shall prepare a check drawn to the supplier based upon the data provided. This check will be released and remitted directly to the supplier. The Vendor/Contractor agrees to assist the County to immediately obtain partial or final release of waivers as appropriate.
- R. At the end of the project Vendor/Contractor will be provided with a deductive Change Order for the costs incurred by County to provide all ODP, not covered by previous change orders. Salvage materials shall be stored or removed from the site at the County's direction, or may be turned over to the Vendor/Contractor by the County for salvage or disposal at the Vendor/Contractor's option.

## 6. SPECIAL CONDITIONS

### 6.1. TIME OF COMPLETION

Bidder agrees that the work will be substantially complete within three hundred sixty-five (365 ) calendar days after the commencement date indicated in the Notice to Proceed and ready for final payment within three hundred and eighty (380) calendar days after the date indicated on the Notice to Proceed. The timeframe between substantial and final is thirty fifteen (15) calendar days. Completion time includes material ordering lead times. Materials shall not be ordered by the Vendor/Contractor until the Notice to Proceed has been issued.

### 6.2. STARTING THE WORK

- A. Before undertaking each part of the work, the Vendor/Contractor shall:
1. Carefully study and compare the Contract Documents and check and verify pertinent figures shown thereon and all applicable field measurements. Vendor/Contractor shall promptly report in writing to the Project Manager any conflict, error or discrepancy which the Vendor/Contractor may discover and shall obtain a written interpretation or clarification from the Project Manager before proceeding with any work affected thereby; however, Vendor/Contractor shall not be liable to County for failure to report any conflict, error or discrepancy in the Contract Documents, unless Vendor/Contractor had actual knowledge, or should reasonably have known thereof.
  2. Within ten (10) calendar days after the effective date of the Agreement (unless otherwise specified), Vendor/Contractor shall submit to the Engineer for review:
    - a. A preliminary Progress Schedule indicating the times (number of days or dates) for starting and completing the various stages of the work, including milestones specified in the Contract Documents;
    - b. A preliminary schedule of shop drawings and sample submittals which will list each required submittal and the times for submitting, reviewing, and processing such submittal; and
    - c. A preliminary Schedule of Values for all the work which will include quantities and prices of items aggregating the contract price and will subdivide the work into component parts in sufficient detail to serve as the basis for progress payments during construction. Such prices will include an appropriate amount of overhead and profit applicable to each item of work.
- B. The Vendor/Contractor will start the work within ten (10) calendar days of the official Notice to Proceed date. The Contract Time shall commence to run from the date of the Notice to Proceed.

### 6.3. LIQUIDATED DAMAGES

- A. Bidders hereby agree that time is of the essence and that a precise determination of actual damages which could be incurred by the County for delay in the completion of the work provided herein would be difficult to ascertain. Accordingly the parties agree that the liquidated damages for those items of damage not otherwise provided for by the bid documents, for each and every day that the time consumed in completing the work provided for herein exceeds the time allowed in achieving substantial completion and/or final completion therefore shall be in accordance with the amount(s) set forth in Construction Agreement, Article 3, Paragraph 3.03, of the contract documents. The parties specifically agree that the liquidated damages provided herein do not constitute a penalty. The amount of liquidated damages occasioned by the Vendor/Contractor's delay will be deducted and retained out of the monies payable to the Vendor/Contractor. If not so deducted the Vendor/Contractor and sureties for the Vendor/Contractor shall be liable thereof.
- B. Vendor/Contractor and Owner agree for each consecutive calendar day that the work remains incomplete after the Contract date established for Substantial Completion and/or Final Completion, the County will retain from the compensation otherwise to be paid to the Vendor/Contractor the sum of **\$200.00 per day**. This amount is the minimum measure of damages the County will sustain by failure of the Vendor/Contractor to complete all remedial work, correct deficient work, clean up the project and other miscellaneous tasks as required to complete all work specified.

### 6.4. INTERPRETATION AND INTENT OF THE CONTRACT DOCUMENTS

- A. It is the intent of the specifications and drawings to describe a complete project to be constructed in accordance with the Contract Documents. Any labor, documentation, services, materials, or equipment that may reasonably be inferred from the Contract Documents or from prevailing custom or trade usage as being required to produce the intended result will be provided whether or not specifically called for at no additional cost to Owner.
- B. The Contract Documents are complementary; what is called for by one (1) is as binding as if called for by all.
- C. Reference Standards:
  - 1. Reference to standards, specifications, manuals, or codes of any technical society, organization, or association, or to laws or regulations, whether such reference be specific or by implication, shall mean the standard, specification, manual, code, or laws or regulations in effect at the time of opening of bids (or on the effective date of the Agreement if there were no bids), except as may be otherwise specifically stated in the Contract Documents.
  - 2. No provision of any such standard, specification, manual or code, or any instruction of a supplier shall be effective to change the duties or responsibilities of Owner,

Vendor/Contractor, or Engineer, or any of their subcontractors, consultants, agents, or employees from those set forth in the Contract Documents. No such provision or instruction shall be effective to assign to Owner, or Engineer, or any of their related entities, any duty or authority to supervise or direct the performance of the work or any duty or authority to undertake responsibility inconsistent with the provisions of the Contract Documents.

- D. If, during the performance of the work, the Vendor/Contractor discovers any conflict, error, ambiguity, or discrepancy within the Contract Documents or between the Contract Documents and any provision of any law or regulation applicable to the performance of the work or of any standard, specification, manual or code, or of any instruction of any supplier, Vendor/Contractor shall promptly report it to Engineer in writing. Vendor/Contractor shall not proceed with the work affected thereby until an amendment or supplement to the Contract Documents has been issued. The more stringent requirements shall apply unless otherwise approved.
- E. The Vendor/Contractor shall take no advantage of any error or omission in the plans or of any discrepancy between the plans and specifications, and the professional shall make such interpretation as may be deemed necessary for the fulfillment of the intent of the plans and specifications as construed by him and his decision shall be final.
- F. Vendor/Contractor shall make reasonable efforts to identify potential changes which may enhance efficiency, reliability, serviceability or economy of operation, accelerate the construction schedule, reduce cost of construction, or otherwise enhance any benefits to Hernando County. The Vendor/Contractor, in its reasonable judgment, may propose in writing to Hernando County any such potential change, along with its proposed effect on the cost of the work or the installation schedule. Hernando County shall consider any such proposed change in good faith and may, in its sole discretion, approve in writing any such change.
- G. Reuse of Documents:
  - 1. Vendor/Contractor and any subcontractor or supplier shall not:
    - a. Have or acquire any title to or ownership rights in any of the drawings, specifications, or other documents (or copies of any thereof) prepared by or bearing the seal of Engineer or Engineer's consultants, including electronic media editions; or
    - b. Reuse any of such drawings, specifications, other documents, or copies thereof on extensions of the project or any other project without written consent of Owner and Engineer and specific written verification or adaptation by Engineer.
  - 2. The prohibition of this paragraph will survive final payment, or termination of the Contract. Nothing herein shall preclude Vendor/Contractor from retaining copies of the Contract Documents for record purposes.
- H. Electronic Data:

1. Copies of data furnished by Owner or Engineer to Vendor/Contractor that may be relied upon are limited to the printed copies (also known as hard copies). Files in electronic media format of text, data, graphics, or other types are furnished only for the convenience of the receiving party. Any conclusion or information obtained or derived from such electronic files will be at the user's sole risk. If there is a discrepancy between the electronic files and the hard copies, the hard copies govern.
2. Because data stored in electronic media format can deteriorate or be modified inadvertently or otherwise without authorization of the data's creator, the party receiving electronic files agrees that it will perform acceptance tests or procedures within sixty (60) days, after which the receiving party shall be deemed to have accepted the data thus transferred. Any errors detected within the sixty (60) day acceptance period will be corrected by the transferring party.
3. When transferring documents in electronic media format, the transferring party makes no representations as to long term compatibility, usability, or readability of documents resulting from the use of software application packages, operating systems, or computer hardware differing from those used by the data's creator.

#### 6.5. COMPLIANCE WITH OCCUPATIONAL SAFETY AND HEALTH ACT (OSHA)

All construction practices, material, equipment, etc., as proposed and offered by Bidders must meet and conform to all OSHA. requirements; the Bidder's signature upon the Bid Form in these bid documents, being by this reference considered a certification of such fact.

#### 6.6. OWNER'S RESPONSIBILITIES AFTER AWARD

- A. Communications to Vendor/Contractor: Except as otherwise provided in these Contract Documents, Owner shall issue all communications to Vendor/Contractor through designated Authorized Owner Representative.
- B. Furnish Data: Owner shall promptly furnish the data required of Owner under the Contract Documents.
- C. Pay When Due: Owner shall make payments to Vendor/Contractor when they are due as provided in the Contract Documents.
- D. Lands and Easements; Reports and Tests: Owner's duties to provide lands and easements and to provide engineering surveys to establish reference points are set forth in the Contract Documents. Owner shall identify and make available to Vendor/Contractor copies of reports of explorations and tests of subsurface conditions and drawings of physical conditions in or relating

to existing surface or subsurface structures at or contiguous to the site that have been utilized by the Engineer in preparing the Contract Documents.

- E. Change Orders: Owner is obligated to execute change orders as indicated in the Contract Documents.
- F. Inspections, Tests, and Approvals: Owner's responsibility regarding certain inspections, tests, and approvals is set forth in the Contract Documents.
- G. Limitations on Owner's Responsibilities: The Owner shall not supervise, direct, or have control or authority over, nor be responsible for, Vendor/Contractor's means, methods, techniques, sequences, or procedures of construction, or the safety precautions and programs incident thereto, or for any failure of Vendor/Contractor to comply with laws and regulations applicable to the performance of the work. Owner will not be responsible for Vendor/Contractor's failure to perform the work in accordance with the Contract Documents.
- H. Undisclosed Hazardous Environmental Condition: Owner's responsibility regarding undisclosed hazardous environmental conditions is set forth in the Contract Documents.
- I. Evidence of Financial Arrangements: Owner's responsibility, if any, to furnish Vendor/Contractor reasonable evidence that financial arrangements have been made to satisfy Owner's obligations under the Contract Documents will be as set forth in the Contract Documents

## 6.7. OWNER DESIGNATED REPRESENTATIVE'S STATUS DURING CONSTRUCTION

- A. Owner's Designated Representative: The duties and responsibilities and the limitations of authority of the Owner's Designated Representative during construction are set forth in the Contract Documents and will not be changed without written consent of Owner.
- B. Visits to Site:
  - 1. Owner's Designated Representative will make visits to the site at intervals appropriate to the various stages of construction as the Owner Designated Representative deems necessary in order to observe as an experienced and qualified design professional the progress that has been made and the quality of the various aspects of Vendor/Contractor's executed work. Based on information obtained during such visits and observations, the Owner Designated Representative will determine, in general, if the work is proceeding in accordance with the Contract Documents. The Owner Designated Representative will not be required to make exhaustive or continuous inspections on the site to check the quality or quantity of the work. Owner Designated Representative's efforts will be directed toward providing for Owner a greater degree of confidence that the completed work will conform generally to the Contract Documents. On the basis of such visits and observations, Owner Designated Representative will keep Owner informed of the progress of the work and will endeavor to guard Owner against defective work.

2. Owner Designated Representative's visits and observations are subject to all the limitations on Owner Designated Representative's authority and responsibility set forth in paragraph titled "LIMITATIONS ON OWNER DESIGNATED REPRESENTATIVE'S AUTHORITY AND RESPONSIBILITIES". Particularly, but without limitation, during or as a result of Owner Designated Representative's visits or observations of Vendor/Contractor's work Owner Designated Representative will not supervise, direct, control, or have authority over or be responsible for Vendor/Contractor's means, methods, techniques, sequences, or procedures of construction, or the safety precautions and programs incident thereto, or for any failure of Vendor/Contractor to comply with laws and regulations applicable to the performance of the work.
- C. Project Representative: If Owner and Owner Designated Representative agree, Owner Designated Representative will furnish a Resident Project Representative to assist Owner Designated Representative in providing more extensive observation of the work. The authority and responsibilities of any such Resident Project Representative and assistants is provided in paragraph titled "LIMITATIONS ON OWNER DESIGNATED REPRESENTATIVE'S AUTHORITY AND RESPONSIBILITIES", and limitations on the responsibilities thereof are provided below. If Owner designates another representative or agent to represent Owner at the site who is not Engineer's consultant, agent or employee, the responsibilities and authority and limitations thereon of such other individual or entity will be as provided in the Contract Documents.
  - D. Authorized Variations in Work: Owner Designated Representative may authorize minor variations in the work from the requirements of the Contract Documents which do not involve an adjustment in the contract price or the contract times and are compatible with the design concept of the completed project as a functioning whole as indicated by the Contract Documents. These may be accomplished by a field order and will be binding on Owner and also on Vendor/Contractor, who shall perform the work involved promptly. If Owner or Vendor/Contractor believes that a field order justifies an adjustment in the contract price or contract times, or both, and the parties are unable to agree on entitlement to or on the amount or extent, if any, of any such adjustment, a claim may be made therefore as provided in Section titled "CHANGES IN THE WORK; CLAIMS" paragraph entitled "CLAIMS".
  - E. Rejecting Defective Work: Owner Designated Representative will have authority to reject work which Owner Designated Representative believes to be defective, or that Owner Designated Representative believes will not produce a completed project that conforms to the Contract Documents or that will prejudice the integrity of the design concept of the completed project as a functioning whole as indicated by the Contract Documents. Owner Designated Representative will also have authority to require special inspection or testing of the work as provided in Section titled "TESTS AND INSPECTIONS; CORRECTIONS, REMOVAL/ACCEPTANCE OF DEFECTIVE WORK: paragraph titled "TESTS AND INSPECTIONS", whether or not the work is fabricated, installed, or completed.

- F. Determinations for Unit Price Work: Owner Designated Representative will determine the actual quantities and classifications of unit price work performed by Vendor/Contractor. Owner Designated Representative will review with Vendor/Contractor the Owner Designated Representative's preliminary determinations on such matters before rendering a written decision thereon (by recommendation of an application for payment or otherwise). Owner Designated Representative's written decision thereon will be final and binding (except as modified by Owner Designated Representative to reflect changed factual conditions or more accurate data) upon Owner and Vendor/Contractor, subject to the provisions Section titled "COST OF THE WORK; ALLOWANCES; UNIT PRICE WORK" paragraph titled "VENDOR/CONTRACTOR'S FEE".
- G. Decisions on Requirements of Contract Documents and Acceptability of Work:
1. Owner Designated Representative will be the initial interpreter of the requirements of the Contract Documents and judge of the acceptability of the work thereunder. All matters in question and other matters between Owner and Vendor/Contractor arising prior to the date final payment is due relating to the acceptability of the work, and the interpretation of the requirements of the Contract Documents pertaining to the performance of the work, will be referred initially to Owner Designated Representative in writing within thirty (30) days of the event giving rise to the question.
  2. Owner Designated Representative will, with reasonable promptness, render a written decision on the issue referred and obtain Owner's approval to issue decision. If Owner or Vendor/Contractor believes that any such decision entitles them to an adjustment in the contract price or contract times or both, a claim may be made under the provision stated in Section titled "CHANGES IN THE WORK; CLAIMS" paragraph entitled "CLAIMS".
  3. Owner Designated Representative's written decision on the issue referred will be final and binding on Owner and Vendor/Contractor, subject to the provisions in paragraph titled "LIMITATIONS ON OWNER DESIGNATED REPRESENTATIVE'S AUTHORITY AND RESPONSIBILITIES".
  4. When functioning as interpreter and judge under paragraph titled "DECISIONS ON REQUIREMENTS OF CONTRACT DOCUMENTS AND ACCEPTABILITY OF WORK", Owner Designated Representative will not show partiality to Owner or Vendor/Contractor and will not be liable in connection with any interpretation or decision rendered in good faith in such capacity.
- H. Limitations on Owner Designated Representative's Authority and Responsibilities:
1. Neither Owner Designated Representative's authority or responsibility under this paragraph or under any other provision of the Contract Documents nor any decision made by Owner Designated Representative in good faith either to exercise or not exercise such authority or responsibility or the undertaking, exercise, or performance of any authority or responsibility

- by Owner Designated Representative shall create, impose, or give rise to any duty in contract, tort, or otherwise owed by Owner Designated Representative to Vendor/Contractor, any subcontractor, any supplier, any other individual or entity, or to any surety for or employee or agent of any of them.
2. Owner Designated Representative will not supervise, direct, control, or have authority over or be responsible for Vendor/Contractor's means, methods, techniques, sequences, or procedures of construction, or the safety precautions and programs incident thereto, or for any failure of Vendor/Contractor to comply with laws and regulations applicable to the performance of the work. Owner Designated Representative will not be responsible for Vendor/Contractor's failure to perform the work in accordance with the Contract Documents.
  3. Owner Designated Representative will not be responsible for the acts or omissions of Vendor/Contractor or of any subcontractor, any supplier, or of any other individual or entity performing any of the work.
  4. Owner Designated Representative's review of the application for payment and accompanying documentation and all maintenance and operating instructions, schedules, guarantees, bonds, certificates of inspection, tests and approvals, and other documentation required to be delivered by Section titled "PAYMENTS TO CONTRACTOR AND COMPLETION" paragraph titled "REVIEW OF APPLICATIONS" will only be to determine generally that their content complies with the requirements of, and in the case of certificates of inspections, tests, and approvals that the results certified indicate compliance with the Contract Documents.
  5. The limitations upon authority and responsibility set forth in this paragraph shall also apply to the Resident Project Representative, if any, and assistants, if any.

## 6.8. CONTRACTOR'S RESPONSIBILITIES

### A. Supervision and Superintendence:

1. The Vendor/Contractor will supervise and direct the work efficiently and with his best skill and attention. He will be solely responsible for the means, methods, techniques, sequences and procedure of construction, unless otherwise specified. The Vendor/Contractor will be responsible to see that the finished work complies accurately with the Contract Documents.
2. The Vendor/Contractor will keep on the site at all times during its progress a competent, Resident Superintendent who shall not be replaced without written notice to the Project Manager. The superintendent will be the Vendor/Contractor's representative at the site and shall have authority to act on behalf of the Vendor/Contractor. All communications given to the superintendent shall be as binding as if given to the Vendor/Contractor.

**B. Labor, Materials and Equipment:**

1. The Vendor/Contractor will provide competent, suitable, qualified personnel to lay out the work and perform construction as required by the Contract Documents. He will at all times maintain good discipline and order at the site.
2. Unless otherwise specified in the Contract Documents, Vendor/Contractor shall furnish all materials, equipment, labor, transportation, construction equipment and machinery, tools, appliances, fuel, power, light, heat, telephone, water and sanitary facilities and incidentals necessary for the execution, testing, initial operation and completion of the work.
3. All materials and equipment will be new except as otherwise provided in the Contract Documents. All special warranties and guarantees required by the specifications shall expressly run to the benefit of Owner. If required by the Owner, the Vendor/Contractor will furnish satisfactory evidence (including reports of required tests and/or purchase receipts) as to the source, kind and quality of materials and equipment furnished.
4. All materials and equipment shall be applied, installed, connected, erected, used, cleaned and conditioned in accordance with the instructions of the applicable manufacturer, supplier, fabricator or processors except as otherwise provided in the Contract Documents.

**C. Progress Schedule:**

1. Vendor/Contractor shall adhere to the Progress Schedule requirements established in the Contract Documents as it may be adjusted from time to time as provided below.
  - a. Vendor/Contractor shall submit to Owner Designated Representative for acceptance proposed adjustments in the Progress Schedule that will not result in changing the contract times. Such adjustments will comply with any provisions of the Contract Documents applicable thereto.
  - b. Proposed adjustments in the Progress Schedule that will change the contract times shall be submitted in accordance with the requirements stated in the Contract Documents. Adjustments in contract times may only be made by a change order.
  - c. All work of this Contract shall be scheduled and monitored by the Vendor/Contractor using the Critical Path Method (CPM). The Vendor/Contractor shall prepare the schedule for the project a minimum of two (2) weeks before starting any work and shall submit an updated schedule with each monthly pay request. The Vendor/Contractor will prepare revisions of the schedule to reflect changes in the Vendor/Contractor's plan of performance or changes in the work and submit these revisions to the Owner Designated Representative for acceptance.
  - d. The Vendor/Contractor shall prepare schedules as a time scale logic diagram and bar chart unless otherwise approved by the Owner Designated Representative. Each major

and minor portion of work or operation shall be clearly identified and tied by logical sequence to the shop drawing schedule and schedule of values. All schedules shall be prepared and submitted on 11 inch by 17 inch (11" X 17") paper.

D. Concerning Subcontractors, Suppliers and Others:

1. The Vendor/Contractor will not employ any subcontractor, supplier, other person or entity, whether initially or as a replacement, against whom the Owner may have reasonable objections, nor will the Vendor/Contractor be required to employ any subcontractor, supplier, or other individual or entity, against whom the Vendor/Contractor has reasonable objection.
2. The Vendor/Contractor will not make any substitution for any subcontractor who has been accepted by the Owner, unless the Owner determines that there is good cause for doing so.
3. The Vendor/Contractor will be fully responsible for all acts and omissions of his subcontractors, suppliers, and other individuals or entities performing or furnishing any of the work just as Vendor/Contractor is responsible for Vendor/Contractor's own acts and omissions. Nothing contained in the Contract Documents:
  - a. Shall create for the benefit of any such subcontractor, supplier, or other individual or entity any contractual relationship between Owner or Owner Designated Representative and any such Subcontractor, supplier or other individual or entity, nor
  - b. Shall anything in the Contract Documents create any obligation on the part of Owner or Owner Designated Representative to pay or to see to the payment of any moneys due any such subcontractor, supplier, or other individual or entity except as may otherwise be required by laws and regulations.
4. Vendor/Contractor shall be solely responsible for scheduling and coordinating the work of subcontractors, suppliers, and other individuals or entities performing or furnishing any of the work under a direct or indirect contract with Vendor/Contractor.
5. Vendor/Contractor shall require all subcontractors, suppliers, and such other individuals or entities performing or furnishing any of the work to communicate with Owner Designated Representative through Vendor/Contractor.
6. The divisions and sections of the specifications and the identifications of any drawings shall not control Vendor/Contractor in dividing the work among subcontractors or suppliers or delineating the work to be performed by any specific trade.
7. All work performed for Vendor/Contractor by a subcontractor or supplier will be pursuant to an appropriate agreement between Vendor/Contractor and the subcontractor or supplier which specifically binds the subcontractor or supplier to the applicable terms and conditions of the Contract Documents for the benefit of Owner and Owner Designated Representative.

Whenever any such agreement is with a subcontractor or supplier who is listed as an additional insured on the property insurance as provided in the Contract Documents, the agreement between the Vendor/Contractor and the subcontractor or supplier will contain provisions whereby the subcontractor or supplier waives all rights against Owner, Vendor/Contractor, and Owner Designated Representative, and all other individuals or entities identified in the Contract Documents to be listed as insureds or additional insureds (and the officers, directors, partners, employees, agents, consultants and subcontractors of each and any of them) for all losses and damages caused by, arising out of, relating to, or resulting from any of the perils or causes of loss covered by such policies and any other property insurance applicable to the work. If the insurers on any such policies require separate waiver forms to be signed by any subcontractor or supplier, Vendor/Contractor will obtain the same.

8. The Vendor/Contractor agrees to bind specifically every subcontractor to the applicable terms and conditions of the Contract Documents for the benefit of the Owner.
9. The Vendor/Contractor shall not award work valued at more than fifty percent (50%) of the contract price to subcontractor(s), without prior written approval of the Owner.

## 6.9. CONTRACTOR'S RESPONSIBILITIES (continued)

### A. Patent Fees And Royalties:

1. Vendor/Contractor shall pay all license fees and royalties and assume all costs incident to the use in the performance of the work or the incorporation in the work of any invention, design, process, product, or device which is the subject of patent rights or copyrights held by others. If a particular invention, design, process, product, or device is specified in the Contract Documents for use in the performance of the work and if to the actual knowledge of Owner or Owner Designated Representative its use is subject to patent rights or copyrights calling for the payment of any license fee or royalty to others, the existence of such rights shall be disclosed by Owner in the Contract Documents.
2. To the fullest extent permitted by laws and regulations, Vendor/Contractor shall indemnify and hold harmless Owner and Owner Designated Representative, and the officers, directors, partners, employees, agents, consultants and subcontractors of each and any of them from and against all claims, costs, losses, and damages (including but not limited to all fees and charges of engineers, architects, attorneys, and other professionals and all court or arbitration or other dispute resolution costs) arising out of or relating to any infringement of patent rights or copyrights incident to the use in the performance of the work or resulting from the incorporation in the work of any invention, design, process, product, or device not specified in the Contract Documents.

**B. Use Of Premises:**

1. The Vendor/Contractor will confine his equipment, the storage of materials and equipment, and the operations of his workers to the areas permitted by law, ordinances, permits or the requirements of the Contract Documents and shall not unreasonably encumber the premises with materials or equipment.
2. The Vendor/Contractor shall confine the operation of workmen and equipment, and the storage of materials and equipment to the County's property or to other non-County property or in public right-of-way areas indicated on the contract drawings as including work to be done pursuant to the Contract Documents. In the event the Vendor/Contractor desires to have access to the project site, or perform work or operations pertaining to the Contract on, over or from non-County property adjacent to the project site, the Vendor/Contractor shall obtain written authorization to do so from the respective adjacent property owner(s) prior to using such property. Such written authorization shall include a provision whereby the property owner agrees to hold the County harmless, and to defend the County, in the event of any liability, loss, injury, or claim incurred as a result of the Vendor/Contractors work or operations involving the use of the adjacent non-County property. The County shall be provided with a notarized, certified copy of such written authorization(s) before the Vendor/Contractor commences work or operations or use of such property in connection with work or operations pursuant to this Contract.

**C. Record Documents:**

1. Vendor/Contractor shall maintain in a safe place at the site one (1) record copy of all drawings, specifications, addenda, change orders, field orders, and written interpretations and clarifications in good order and annotated to show changes made during construction. These record documents together with all approved samples and a counterpart of all approved shop drawings will be available to Engineer for reference. Upon completion of the work, these record documents, samples, and shop drawings will be delivered to Engineer for Owner.
2. Record Drawings: The Engineer will prepare a set of record drawings for the project which will include the changes made in materials, equipment, locations, and dimensions of the work. Each month or as otherwise agreed, the Vendor/Contractor shall submit to the Engineer a current listing and description (written and graphic) of each change incorporated into the work since the preceding submittal.

**D. Safety And Protection:**

1. Vendor/Contractor shall be solely responsible for initiating, maintaining, and supervising all safety precautions and programs in connection with the work. Vendor/Contractor shall take all necessary precautions for the safety of, and shall provide the necessary protection to prevent damage, injury or loss to:

- a. All employees on the site and other persons who may be affected by the work:
  - b. All the work and materials and equipment to be incorporated therein, whether in storage on or off the site; and
  - c. Other property at the site or adjacent thereto, including trees, shrubs, lawns, walks, pavements, roadways, structures, utilities and underground facilities not designated for removal, relocation or replacement in the course of construction.
2. Vendor/Contractor shall comply with all applicable laws and regulations relating to the safety of persons or property, or to the protection of persons or property from damage, injury, or loss; and shall erect and maintain all necessary safeguards for such safety and protection. Vendor/Contractor shall notify owners of adjacent property and of underground facilities and other utility owners when prosecution of the work may affect them, and shall cooperate with them in the protection, removal, relocation, and replacement of their property.
  3. All damage, injury, or loss to any property referred to above; caused directly or indirectly, in whole or in part, by Vendor/Contractor, any subcontractor, supplier, or any other individual or entity directly or indirectly employed by any of them to perform any of the work, or anyone for whose acts any of them may be liable, shall be remedied by Vendor/Contractor (except damage or loss attributable to the fault of drawings or specifications or to the acts or omissions of Owner or Engineer, or anyone employed by any of them, or anyone for whose acts any of them may be liable, and not attributable, directly or indirectly, in whole or in part, to the fault or negligence of Vendor/Contractor or any subcontractor, supplier, or other individual or entity directly or indirectly employed by any of them).
  4. Vendor/Contractor's duties and responsibilities for safety and for protection of the work shall continue until such time as all the work is completed and Engineer has issued final acceptance.
  5. Vendor/Contractor shall designate a qualified and experienced safety representative at the site whose duties and responsibilities shall be the prevention of accidents and the maintaining and supervising of safety precautions and programs.
- E. Emergencies: In emergencies affecting the safety or protection of persons or the work or property at the site or adjacent thereto, Vendor/Contractor is obligated to act to prevent threatened damage, injury, or loss. Vendor/Contractor shall give Owner Designated Representative prompt written notice if Vendor/Contractor believes that any significant changes in the work or variations from the Contract Documents have been caused thereby or are required as a result thereof. If Owner Designated Representative determines that a change in the Contract Documents is required because of the action taken by Vendor/Contractor in response to such an emergency, a change order will be issued.

## 6.10. CONTRACTOR'S RESPONSIBILITIES (continued)

### A. Shop Drawings, Samples and Test Specimens, Additional and Special Submittals:

1. Vendor/Contractor shall submit all shop drawings, samples and test specimens, additional and special submittals to Owner Designated Representative for review and approval in accordance with the acceptable Schedule of Submittals. The Vendor/Contractor's attention is directed to the individual specification sections in these Contract Documents which may contain additional and special submittal requirements.

#### a. Shop Drawings:

- i. Submit number of copies specified in the specifications.
- ii. Data shown on the shop drawings will be complete with respect to quantities, dimensions, specified performance and design criteria, materials, and similar data to show Owner Designated Representative the services, materials, and equipment Vendor/Contractor proposes to provide and to enable Owner Designated Representative to review the information for the limited purposes of establishing a reporting procedure and is intended for the Vendor/Contractor's convenience in organizing his work and to permit the Owner Designated Representative to monitor the Vendor/Contractor's progress and understanding of the design.
- iii. Should the Vendor/Contractor propose any item on his field drawings, or incorporate an item into the work, and that item should subsequently prove to be defective or otherwise unsatisfactory, (regardless of the Owner Designated Representative 's preliminary review), the Vendor/Contractor shall, at his own expense, replace the item with another item that will perform satisfactorily.
- iv. The Vendor/Contractor agrees that shop drawing submittals processed by the Owner Designated Representative do not become Contract Documents and are not change orders.

#### b. Samples and Test Specimens:

- i. Submit number of samples and/or test specimens as required in the specifications. Where required in the specifications, and as determined necessary by the Owner Designated Representative, test specimens or samples of materials, appliances, and fittings to be used or offered for use in connection with the work shall be submitted to the Owner Designated Representative at the Vendor/Contractor's expense, with all cartage charges prepaid, and in such quantities and sizes as may be required for proper examination and tests to establish the quality or equality thereof, as applicable.

- ii. Clearly identify each as to material, supplier, pertinent data such as catalog numbers, the use for which intended and other data as Owner Designated Representative may require enabling Owner Designated Representative to review the submittal for the limited purposes of establishing a reporting procedure and is intended for the Vendor/Contractor's convenience in organizing his work and to permit the Owner Designated Representative to monitor the Vendor/Contractor's progress and understanding of the design.
  - iii. All samples and test specimens shall be submitted in ample time to enable the Owner Designated Representative to make any examinations necessary, without delay to the work. The Vendor/Contractor will be held responsible for any loss of time due to his neglect or failure to deliver the required samples to the Owner Designated Representative, as specified.
  - iv. The Vendor/Contractor shall submit additional samples as required by the Owner Designated Representative to ensure equality with the original approved sample and/or for determination of specification compliance.
  - v. Laboratory tests and examinations that the Owner elects to have made by an independent testing laboratory will be made at no cost to the Vendor/Contractor, except that, if a sample of any material or equipment proposed for use by the Vendor/Contractor fails to meet the specifications, the cost of testing subsequent samples shall be borne by the Vendor/Contractor.
  - vi. All tests required by the specifications to be performed by an independent laboratory shall be made by an Owner approved laboratory. Certified test results of all specified tests shall be submitted in duplicate to the Owner Designated Representative. The samples furnished and the cost for the laboratory services shall be at the expense of the Vendor/Contractor and included in the prices bid for the associated work.
  - vii. Sample items (fixtures, hardware, etc.) may be incorporated into the work upon approval, and when no longer needed by the Owner Designated Representative for reference.
- c. Submittals:
- i. All technical submittals shall be fully sufficient in detail for determination of compliance with the Contract Documents.
  - ii. Review or acceptance of substitutions, schedules, shop drawings, lists of materials, and procedures submitted or requested by the Vendor/Contractor shall not add to the Contract amount, and all additional costs which may result therefrom shall be solely the obligation of the Vendor/Contractor.

- iii. The Owner is not precluded, by virtue of review, acceptance, or approval, from obtaining a credit for construction savings resulting from allowed concessions in the work or materials therefore.
    - iv. No equipment or material for which listings, drawings, or descriptive material is required shall be fabricated, purchased, or installed until the Owner Designated Representative has reviewed same and returned copies with stamp and signature indicating action taken.
  - 2. Where shop drawings, samples, additional technical or special submittals are required by the Contract Documents or the Schedule of Submittals, any related work performed prior to Owner Designated Representative's review and approval of the pertinent submittal will be at the sole expense and responsibility of Vendor/Contractor.
  - 3. Submittal Procedures:
    - a. Submittals shall be addressed to the Owner Designated Representative as defined in these construction documents. Before submitting each shop drawing, sample, test specimens or other technical submittal, Vendor/Contractor shall have determined and verified:
      - i. All field measurements, quantities, dimensions, specified performance and design criteria, installation requirements, materials, catalog numbers, and similar information with respect thereto;
      - ii. The suitability of all materials with respect to intended use, fabrication, shipping, handling, storage, assembly, and installation pertaining to the performance of the work;
      - iii. All information relative to Vendor/Contractor's responsibilities for means, methods, techniques, sequences, and procedures of construction, and safety precautions and programs incident thereto; and
      - iv. Shall also have reviewed and coordinated each shop drawing or sample with other shop drawings and samples and with the requirements of the work and the Contract Documents.
    - b. Each submittal shall bear a stamp or specific written certification that Vendor/Contractor has satisfied Vendor/Contractor's obligations under the Contract Documents with respect to Vendor/Contractor's review and approval of that submittal. The practice of submitting incomplete or unchecked shop drawings for the Owner Designated Representative to correct or finish will not be acceptable. shop drawings which, in the opinion of the Owner Designated Representative, clearly indicate that they have not been checked by the Vendor/Contractor will be considered as not complying

with the intent of the Contract Documents and will be returned to the Vendor/Contractor for resubmission in the proper form.

- c. With each submittal, Vendor/Contractor shall give Owner Designated Representative specific written notice of any variations, that the shop drawing or sample may have from the requirements of the Contract Documents. This notice shall be both a written communication separate from the shop drawings or sample submittal; and, in addition, by a specific notation made on each shop drawing or sample submitted to Owner Designated Representative for review and approval of each such variation.
  - d. The Vendor/Contractor shall submit to the Owner Designated Representative for his review five (5) copies of shop drawings, electrical diagrams, performance data and pump curves, wiring and control diagrams, special features, interface schematic diagrams, catalog information and cuts for fabricated items and manufactured items including structural, mechanical, electrical, plumbing, process, instrumentation and control systems and equipment furnished under this Contract. Shop drawings shall be submitted in sufficient time to allow the Owner Designated Representative not less than twenty (20) regular working days for examining the drawings.
4. Owner Designated Representative's Review:
- a. Owner Designated Representative will provide timely review of shop drawings and samples in accordance with the Schedule of Submittals acceptable to Owner Designated Representative. Owner Designated Representative's review and approval will be only to determine if the items covered by the submittals will, after installation or incorporation in the work, conform to the information given in the Contract Documents and be compatible with the design concept of the completed project as a functioning whole as indicated by the Contract Documents.
  - b. Owner Designated Representative's review and approval shall not relieve Vendor/Contractor from responsibility for any variation from the requirements of the Contract Documents unless Vendor/Contractor has complied with the requirements and Owner Designated Representative has given written approval of each such variation by specific written notation thereof incorporated in or accompanying the shop drawing or sample. Owner Designated Representative's review and approval shall not relieve Vendor/Contractor from responsibility for complying with the requirements stated above.
  - c. Owner Designated Representative's review and approval shall not relieve Vendor/Contractor from responsibility for any variation from the requirements of the Contract Documents unless Vendor/Contractor has complied with the requirements and Owner Designated Representative has given written approval of each such variation by specific written notation thereof incorporated in or accompanying the shop drawing or

sample. Owner Designated Representative's review and approval shall not relieve Vendor/Contractor from responsibility for complying with the requirements stated above.

5. Re-submittal Procedures:

- a. Vendor/Contractor shall make corrections required by Owner Designated Representative and shall return the required number of corrected copies of shop drawings and submit, as required, new samples for review and approval. Vendor/Contractor shall direct specific attention in writing to revisions other than the corrections called for by Owner Designated Representative on previous submittals. Costs incurred by Owner Designated Representative, and/or Owner, related to review and approval of additional submittals beyond that associated with the original submittal and one (1) re-submittal will be the responsibility of the Vendor/Contractor.

6. Certificates of Compliance:

- a. A Certificate of Compliance shall be furnished for materials specified to a recognized standard or code prior to the use of any such materials in the work. The Owner Designated Representative may permit the use of certain materials or assemblies prior to sampling and testing if accompanied by a Certificate of Compliance. The certificate shall be signed by the manufacturer of the material or the manufacturer of assembled materials and shall state that the materials involved comply in all respects with the requirement of the specifications. A Certificate of Compliance shall be furnished with each lot of material delivered to the work and the lot so certified shall be clearly identified in the certificate.
- b. All materials used on the basis of a Certificate of Compliance may be sampled and tested at any time. The fact that material is used on the basis of a Certificate of Compliance shall not relieve the Vendor/Contractor of responsibility for incorporating material in the work which conforms to the requirements of the Contract Documents and any such material not conforming to such requirements will be subject to rejection whether in place or not.
- c. The Owner Designated Representative reserves the right to refuse permission for use of material on the basis of a Certificate of Compliance.
- d. The form of the Certificate of Compliance and its disposition shall be as directed by the Owner Designated Representative.

6.11. CONTRACTOR'S RESPONSIBILITIES (continued)

- A. Continuing the Work: Vendor/Contractor shall carry on the work and adhere to the Progress Schedule during all disputes or disagreements with Owner. No work shall be delayed or

postponed pending resolution of any disputes or disagreements, except as permitted in Section titled "CHANGE OF CONTRACT PRICE; CHANGE OF CONTRACT TIMES" paragraph entitled "DELAYS" or as Owner and Vendor/Contractor may otherwise agree in writing.

B. Use of Site and Other Areas:

1. Limitation on Use of Site and Other Areas:

- a. Vendor/Contractor shall confine construction equipment, the storage of materials and equipment, and the operations of workers to the site and other areas permitted by laws and regulations, and shall not unreasonably encumber the site and other areas with construction equipment or other materials or equipment. Vendor/Contractor shall assume full responsibility for any damage to any such land or area, or to the owner or occupant thereof, or of any adjacent land or areas resulting from the performance of the work.
- b. Should any claim be made by any such owner or occupant because of the performance of the work, Vendor/Contractor shall promptly settle with such other party by negotiation or otherwise resolve the claim by arbitration or other dispute resolution proceeding or at law.
- c. To the fullest extent permitted by laws and regulations, Vendor/Contractor shall indemnify and hold harmless Owner and Owner Designated Representative, and the officers, directors, partners, employees, agents, consultants and subcontractors of each and any of them from and against all claims, costs, losses, and damages (including but not limited to all fees and charges of engineers, architects, attorneys, and other professionals and all court or arbitration or other dispute resolution costs) arising out of or relating to any claim or action, legal or equitable, brought by any such owner or occupant against Owner, Owner Designated Representative, or any other party indemnified hereunder to the extent caused by or based upon Vendor/Contractor's performance of the work.

2. Removal of Debris During Performance of the Work: During the progress of the work Vendor/Contractor shall keep the site and other areas free from accumulations of waste materials, rubbish, and other debris. Removal and disposal of such waste materials, rubbish, and other debris shall conform to applicable laws and regulations.

3. Clean Up: The Vendor/Contractor will keep the premises free from accumulations of waste materials, rubbish and other debris resulting from the work; at the completion of the work he will remove all waste materials, rubbish and debris from and about the premises as well as all tools, construction equipment and machinery, and surplus materials, and will leave the site clean and ready for occupancy by the County. The Vendor/Contractor will restore to their original condition those portions of the site not designated for alteration by the Contract Documents. If at any time during construction of this project, the

Vendor/Contractor fails to clean up on a daily basis, the County may do so. All costs associated with the County's cleanup activities on behalf of the Vendor/Contractor shall be deducted from amounts due to the Vendor/Contractor. Prior to Substantial Completion of the work, Vendor/Contractor shall clean the site and the work and make it ready for utilization by Owner. At the completion of the work Vendor/Contractor shall remove from the site all tools, appliances, construction equipment and machinery, and surplus materials and shall restore to original condition all property not designated for alteration by the Contract Documents.

4. Loading Structures: Vendor/Contractor shall not load nor permit any part of any structure to be loaded in any manner that will endanger the structure, nor shall Vendor/Contractor subject any part of the work or adjacent property to stresses or pressures that will endanger it.

C. Vendor/Contractor's General Warranty and Guarantee:

1. Vendor/Contractor warrants and guarantees to Owner that all work will be in accordance with the Contract Documents and will not be defective. Owner Designated Representative and its related entities shall be entitled to rely on representation of Vendor/Contractor's warranty and guarantee. All unsatisfactory work, all faulty work, and all work not conforming to the requirements of the Contract Documents or any inspections, test or approvals shall be considered defective. All defective work, whether or not in place, may be rejected, corrected or accepted as provided in the Bid Specification.
2. Vendor/Contractor's warranty and guarantee hereunder excludes defects or damage caused by:
  - a. Abuse, modification, or improper maintenance or operation by persons other than Vendor/Contractor, subcontractors, suppliers, or any other individual or entity for whom Vendor/Contractor is responsible; or
  - b. Normal wear and tear under normal usage.
3. Vendor/Contractor's obligation to perform and complete the work in accordance with the Contract Documents shall be absolute. None of the following will constitute an acceptance of work that is not in accordance with the Contract Documents or a release of Vendor/Contractor's obligation to perform the work in accordance with the Contract Documents:
  - a. Observations by Owner Designated Representative;
  - b. Recommendation by Owner Designated Representative or payment by Owner of any progress or final payment;

- c. The issuance of a certificate of Substantial Completion by Owner Designated Representative or any payment related thereto by Owner;
  - d. Use or occupancy of the work or any part thereof by Owner;
  - e. Any review and approval of a shop drawing or sample submittal or the issuance of a notice of acceptability by Owner Designated Representative;
  - f. Any inspection, test, or approval by others; or
  - g. Any correction of defective work by Owner.
4. The Vendor/Contractor shall provide and maintain in a neat and sanitary condition, such accommodations for the use of his employees as may be necessary to comply with the requirements of the state board of health or of the Owner Designated Representative.
  5. The Vendor/Contractor shall be responsible for installing, operating and maintaining all traffic control associated with the project, including detours, advance warnings, channelization or other features, both at the immediate work site and at any outlying points determined by the Owner to be necessary to satisfy project requirements and to maintain safe operations at the landfill. If traffic control is necessary, the Vendor/Contractor shall prepare a detailed traffic control plan. This plan shall be approved in writing by the Owner prior to implementation by the Vendor/Contractor.

D. Delegation of Professional Design Services:

1. Vendor/Contractor will not be required to provide professional design services unless such services are specifically required by the Contract Documents for a portion of the work or unless such services are required to carry out Vendor/Contractor's responsibilities for construction means, methods, techniques, sequences and procedures. Vendor/Contractor shall not be required to provide professional services in violation of applicable law.
2. If professional design services or certifications by a design professional related to systems, materials or equipment are specifically required of Vendor/Contractor by the Contract Documents, Owner and Owner Designated Representative will specify all performance and design criteria that such services must satisfy. Vendor/Contractor shall cause such services or certifications to be provided by a properly licensed professional, whose signature and seal shall appear on all drawings, calculations, specifications, certifications, shop drawings and other submittals prepared by such professional. Shop drawings and other submittals related to the work designed or certified by such professional, if prepared by others, shall bear such professional's written approval when submitted to Owner Designated Representative.
3. Owner and Owner Designated Representative shall be entitled to rely upon the adequacy, accuracy and completeness of the services, certifications or approvals performed by such

design professionals, provided Owner and Owner Designated Representative have specified to Vendor/Contractor all performance and design criteria that such services must satisfy.

4. Owner Designated Representative's review and approval of design calculations and design drawings will be only for the limited purpose of checking for conformance with performance and design criteria given and the design concept expressed in the Contract Documents. Owner Designated Representative's review and approval of shop drawings and other submittals (except design calculations and design drawings) will be only for the purpose of determining if the items covered by the submittals will, after installation or incorporation in the work, conform to the information given in the Contract Documents and be compatible with the design concept of the completed project as a functioning whole as indicated by the Contract Documents.
5. Vendor/Contractor shall not be responsible for the adequacy of the performance or design criteria required by the Contract Documents.

#### 6.12. AVAILABILITY OF LANDS; SUBSURFACE AND PHYSICAL CONDITIONS; HAZARDOUS ENVIRONMENTAL CONDITIONS; REFERENCE POINTS:

##### A. Availability of Lands:

1. Owner shall furnish the site. Owner shall notify Vendor/Contractor of any encumbrances or restrictions not of general application but specifically related to use of the site with which Vendor/Contractor must comply in performing the work. Owner will obtain in a timely manner and pay for easements for permanent structures or permanent changes in existing facilities. If Vendor/Contractor and Owner are unable to agree on entitlement to or on the amount or extent, if any, of any adjustment in the contract price or contract times, or both, as a result of any delay in Owner's furnishing the site or a part thereof, Vendor/Contractor may make a claim therefore as provided in the Contract Documents.
2. Upon reasonable written request, Owner shall furnish Vendor/Contractor with a current statement of record legal title and legal description of the lands upon which the work is to be performed and Owner's interest therein as necessary for giving notice of or filing a mechanic's or construction lien against such lands in accordance with applicable laws and regulations.
3. Vendor/Contractor shall provide for all additional lands and access thereto that may be required for temporary construction facilities or storage of materials and equipment.

##### B. Subsurface and Physical Conditions:

1. Reports and Drawings:

- a. Those reports of explorations and tests of subsurface conditions at or contiguous to the site that Owner Designated Representative has used in preparing the Contract Documents; and
  - b. Those drawings of physical conditions in or relating to existing surface or subsurface structures at or contiguous to the site (except underground facilities) that Engineer has used in preparing the Contract Documents will be included in the Contract Documents as Attachments.
2. Limited reliance by Vendor/Contractor on technical data authorized: Vendor/Contractor may rely upon the general accuracy of the technical data contained in such reports and drawings, but such reports and drawings are not Contract Documents. Such technical data is identified in the Contract Documents. Except for such reliance on such technical data, Vendor/Contractor may not rely upon or make any claim against Owner or Engineer, or any of their related entities with respect to:
  - a. The completeness of such reports and drawings for Vendor/Contractor's purposes, including, but not limited to, any aspects of the means, methods, techniques, sequences, and procedures of construction to be employed by Vendor/Contractor,
  - b. Other data, interpretations, opinions, and information contained in such reports or shown or indicated in such drawings; or
  - c. Any Vendor/Contractor interpretation of or conclusion drawn from any technical data or any such other data, interpretations, opinions, or information.
3. Differing Subsurface or Physical Conditions:
  - a. Notice: If Vendor/Contractor believes that any subsurface or physical condition at or contiguous to the site that is uncovered or revealed either:
    - i. Is of such a nature as to establish that any technical data on which Vendor/Contractor is entitled to rely as provided in Titled "UNDERGROUND FACILITIES" is materially inaccurate; or
    - ii. Is of such a nature as to require a change in the Contract Documents; or
    - iii. Differs materially from that shown or indicated in the Contract Documents; or
    - iv. Is of an unusual nature, and differs materially from conditions ordinarily encountered and generally recognized as inherent in work of the character provided for in the Contract Documents; then Vendor/Contractor shall, promptly after becoming aware thereof and before further disturbing the subsurface or physical conditions or performing any work in connection therewith, notify Owner and Owner Designated Representative in writing about such condition.

Vendor/Contractor shall not further disturb such condition or perform any work in connection therewith until receipt of written order to do so.

- b. Owner Designated Representative's Review: After receipt of written notice, Owner Designated Representative will promptly review the pertinent condition, determine the necessity of Owner's obtaining additional exploration or tests with respect thereto, and advise Owner in writing (with a copy to Vendor/Contractor) of Owner Designated Representative's findings and conclusions.
- c. Possible Price and Times Adjustments:
  - i. The contract price or the contract times, or both, will be equitably adjusted to the extent that the existence of such differing subsurface or physical condition causes an increase or decrease in Vendor/Contractor's cost of, or time required for, performance of the work; subject, however, to the following:
    - I. Such condition must meet any one (1) or more of the categories described in Section Titled "CHANGE OF CONTRACT PRICE; CHANGE OF CONTRACT TIMES" paragraph titled "DELAYS" and
    - II. With respect to work that is paid for on a unit price basis, any adjustment in contract price will be subject to the provisions of stated in the Contract Documents.
  - ii. Vendor/Contractor shall not be entitled to any adjustment in the contract price or contract times if:
    - I. Vendor/Contractor knew of the existence of such conditions at the time Vendor/Contractor made a final commitment to Owner with respect to contract price and contract times by the submission of a bid or becoming bound under a negotiated Contract; or
    - II. The existence of such condition could reasonably have been discovered or revealed as a result of any examination, investigation, exploration, test, or study of the site and contiguous areas required by the bidding requirements or Contract Documents to be conducted by or for Vendor/Contractor prior to Vendor/Contractor's making such final commitment; or
    - III. Vendor/Contractor failed to give the written notice as required by provisions above.
  - iii. If Owner and Vendor/Contractor are unable to agree on entitlement to or on the amount or extent, if any, of any adjustment in the contract price or contract times, or both, a claim may be made therefore as provided in Contract Documents. However, Owner and Owner Designated Representative, and any of their related

entities shall not be liable to Vendor/Contractor for any claims, costs, losses, or damages (including but not limited to all fees and charges of engineers, architects, attorneys, and other professionals and all court or arbitration or other dispute resolution costs) sustained by Vendor/Contractor on or in connection with any other project or anticipated project.

4. Underground Facilities:

- a. Shown or Indicated: The information and data shown or indicated in the Contract Documents with respect to existing underground facilities at or contiguous to the site is based on information and data furnished to Owner or Engineer by the owners of such underground facilities, including Owner, or by others. Unless it is otherwise expressly provided in the Bid documents:
  - i. Owner and Engineer shall not be responsible for the accuracy or completeness of any such information or data; and
  - ii. The cost of all of the following will be included in the contract price, and Vendor/Contractor shall have full responsibility for:
    - I. Reviewing and checking all such information and data,
    - II. Locating all underground facilities shown or indicated in the Contract Documents,
    - III. Coordination of the work with the owners of such underground facilities, including Owner, during construction, and
    - IV. The safety and protection of all such underground facilities and repairing any damage thereto resulting from the work.
  - iii. The Vendor/Contractor shall locate all existing utilities, vertical and horizontal, prior to commencement of construction and any excavation.
- b. Not Shown or Indicated:
  - i. If an underground facility is uncovered or revealed at or contiguous to the site which was not shown or indicated, or not shown or indicated with reasonable accuracy in the Contract Documents, Vendor/Contractor shall, promptly after becoming aware thereof and before further disturbing conditions affected thereby or performing any work in connection therewith, identify the owner of such underground facility and give written notice to that owner and to Owner and Engineer. Engineer will promptly review the underground facility and determine the extent, if any, to which a change is required in the Contract Documents to reflect and document the consequences of the existence or location of the underground facility. During such

time, Vendor/Contractor shall be responsible for the safety and protection of such underground facility.

- ii. If Engineer concludes that a change in the Contract Documents is required, a Change Order will be issued to reflect and document such consequences. An equitable adjustment shall be made in the contract price or contract times, or both, to the extent that they are attributable to the existence or location of any underground facility that was not shown or indicated or not shown or indicated with reasonable accuracy in the Contract Documents and that Vendor/Contractor did not know of and could not reasonably have been expected to be aware of or to have anticipated. If Owner and Vendor/Contractor are unable to agree on entitlement to or on the amount or extent, if any, of any such adjustment in contract price or contract times, Owner or Vendor/Contractor may make a claim therefore as provided in the Contract Documents.
- c. Obstructions:
- i. Any pipes, conduits, wires, mains, footings, driveways, or other structures encountered shall be carefully protected from injury or displacement. Any damage thereto shall be fully, promptly, and properly repaired by the Vendor/Contractor to the satisfaction of the Owner Designated Representative and the Owner thereof. Should it become necessary to change the position of water or gas or other pipes, sewer drains, or poles, the Engineer shall be at once notified of the locality and circumstances, and no claims for damages arising from the delay in adjusting the pipe, sewer drains or poles shall be made. Failure of the plans to show the locations, nature or extent of any existing structures or obstructions shall not be the basis of a claim for extra work. Any survey monument or bench mark which must be disturbed shall be carefully referenced before removal, and unless otherwise provided for, shall be replaced upon completion of the work by a registered land surveyor. Any survey monuments or bench markers which are disturbed shall be replaced by a Florida registered land surveyor.

**6.13. AVAILABILITY OF LANDS; SUBSURFACE AND PHYSICAL CONDITIONS; HAZARDOUS ENVIRONMENTAL CONDITIONS; REFERENCE POINTS:**  
**(continued)**

**A. Reference Points:**

- 1. Owner shall provide engineering surveys to establish reference points for construction which in Owner Designated Representative's judgment are necessary to enable Vendor/Contractor to proceed with the work. Vendor/Contractor shall be responsible for laying out the work, shall protect and preserve the established reference points and property monuments, and shall make no changes or relocations without the prior written

- approval of Owner. Vendor/Contractor shall report to Owner Designated Representative whenever any reference point or property monument is lost or destroyed or requires relocation because of necessary changes in grades or locations, and shall be responsible for the accurate replacement or relocation of such reference points or property monuments by professionally qualified personnel.
2. Vendor/Contractor will furnish all surveys and construction stakeouts unless otherwise specified. The Vendor/Contractor will provide horizontal control and bench marks or elevations for vertical control. The number and extent of such control will be designated to the Vendor/Contractor by the Owner Designated Representative prior to bid opening, upon request. It shall be the responsibility of the Vendor/Contractor to check all stakes as set by the Engineer for possible error. The Vendor/Contractor shall furnish, free of charge, all additional stakes, all templates, and other materials necessary for marking and maintaining points and lines given. The Vendor/Contractor shall be held responsible for the preservation of all stakes and marks, and if any of the stakes or marks are destroyed or disturbed, the cost of replacing them shall be charged against, and shall be deducted from the payment for the work. The Vendor/Contractor shall be responsible for any mistakes that may be caused by their unnecessary loss or disturbance.
  3. The Vendor/Contractor shall provide reasonable and necessary opportunities and facilities for setting points and making measurements. He shall not proceed until he has made timely demand upon the Owner Designated Representative for, and received from him, such points as may be necessary as the work progresses. The work shall be done in strict conformity with such points.
    - a. Alignment Markers. The markers for alignment and location information which are shown on the plans have been previously established by a Florida registered land surveyor. Monuments and other field markers consist of railroad spikes, iron pins, concrete monuments, and other markers in customary use in the area. The Vendor/Contractor shall lay out his work from these markers, and shall be responsible for all measurements in connection therewith. The Vendor/Contractor shall preserve all alignment and right-of-way markers, and shall reset or replace at his own expense, any and all which are removed, destroyed or covered up by his work. In the event that additional markers, stakes or monuments are required, or in the event that previously established markers must be replaced, the Vendor/Contractor shall employ a Florida registered land surveyor to reset or replace them.
    - b. Bench Marks. The Vendor/Contractor shall lay out his work from bench marks and elevations set by the Engineer. Bench marks and elevations set by the Engineer will be shown and explained to the Vendor/Contractor. Thereafter, these bench marks and elevations become the sole responsibility of the Vendor/Contractor, and if replacement is required, either at the request of the Vendor/Contractor or in the judgment of the

Owner Designated Representative, the Vendor/Contractor shall pay for the cost of replacement. The Vendor/Contractor shall furnish, at his own expense, all templates, stakes, equipment, labor and materials as may be required in laying out any part of the work.

B. Hazardous Environmental Condition at Site:

1. Reports and Drawings: Any reports and drawings relating to a hazardous environmental condition identified at the site, if any, that have been utilized by the Engineer in the preparation of the Contract Documents will be included in the Contract Documents as Attachments under Reference Documents.
2. Limited Reliance by Vendor/Contractor on Technical Data Authorized: Vendor/Contractor may rely upon the general accuracy of the technical data contained in such reports and drawings, but such reports and drawings are not Contract Documents. Such technical data is identified in the Technical Specifications. Except for such reliance on such technical data, Vendor/Contractor may not rely upon or make any claim against Owner or Engineer, or any of their related entities with respect to:
  - a. The completeness of such reports and drawings for Vendor/Contractor's purposes, including, but not limited to, any aspects of the means, methods, techniques, sequences and procedures of construction to be employed by Vendor/Contractor and safety precautions and programs incident thereto; or
  - b. Other data, interpretations, opinions and information contained in such reports or shown or indicated in such drawings;
3. Vendor/Contractor shall not be responsible for any hazardous environmental condition uncovered or revealed at the site which was not shown or indicated in drawings or specifications or identified in the Contract Documents to be within the scope of the work. Vendor/Contractor shall be responsible for a hazardous environmental condition created with any materials brought to the site by Vendor/Contractor, subcontractors, suppliers, or anyone else for whom Vendor/Contractor is responsible.
4. If Vendor/Contractor encounters a hazardous environmental condition or if Vendor/Contractor or anyone for whom Vendor/Contractor is responsible creates a hazardous environmental condition, Vendor/Contractor shall immediately: (i) secure or otherwise isolate such condition; (ii) stop all work in connection with such condition and in any area affected thereby; and (iii) notify Owner and Owner Designated Representative (and promptly thereafter confirm such notice in writing). Owner shall promptly consult with Owner Designated Representative concerning the necessity for Owner to retain a qualified expert to evaluate such condition or take corrective action, if any.

5. Vendor/Contractor shall not be required to resume work in connection with such condition or in any affected area until after Owner has obtained any required permits related thereto and delivered to Vendor/Contractor written notice: (i) specifying that such condition and any affected area is or has been rendered safe for the resumption of work; or (ii) specifying any special conditions under which such work may be resumed safely. If Owner and Vendor/Contractor cannot agree as to entitlement to or on the amount or extent, if any, of any adjustment in contract price or contract times, or both, as a result of such work stoppage or such special conditions under which work is agreed to be resumed by Vendor/Contractor, either party may make a claim therefore as provided in the Contract Documents.
6. If after receipt of such written notice Vendor/Contractor does not agree to resume such work based on a reasonable belief it is unsafe, or does not agree to resume such work under such special conditions, then Owner may order the portion of the work that is in the area affected by such condition to be deleted from the work. If Owner and Vendor/Contractor cannot agree as to entitlement to or on the amount or extent, if any, of an adjustment in contract price or contract times as a result of deleting such portion of the work, then either party may make a claim therefore as provided in the Contract Documents. Owner may have such deleted portion of the work performed by Owner's own forces or others in accordance with Section "Other Work at the Site".
7. The provisions in this paragraph do not apply to a hazardous environmental condition uncovered or revealed at the site.

#### **6.14. PRE-CONSTRUCTION CONFERENCE**

Within fourteen (14) calendar days after the effective date of the contract, but before Vendor/Contractor starts the work at the site, a conference attended by Vendor/Contractor, Owner Designated Representative, and other County staff personnel as appropriate will be held to discuss such topics as may include, but not limited to; schedules, procedures for handling shop drawings and other submittals and for processing Applications for Payment, MOT, initiation of coordination with affected utilities, agreement upon the Notice to Proceed date, and to establish a working understanding among the parties as to the work.

#### **6.15. INITIAL ACCEPTANCE OF SCHEDULES:**

At least ten (10) days before submission of the first application for payment, a conference attended by Vendor/Contractor, Owner Designated Representative, and others as appropriate will be held to review for acceptability to Owner Designated Representative. Vendor/Contractor shall have an additional ten (10) days to make corrections and adjustments and to complete and re-submit the schedules. No progress payment shall be made to Vendor/Contractor until acceptable schedules are submitted to Owner Designated Representative.

- A. The Progress Schedule will be acceptable to Owner Designated Representative if it provides an orderly progression of the work to completion within the contract times. Such acceptance will not impose on Owner Designated Representative responsibility for the Progress Schedule, for sequencing, scheduling, or progress of the work nor interfere with or relieve Vendor/Contractor from Vendor/Contractor's full responsibility therefore.
- B. Vendor/Contractor's Schedule of Submittals will be acceptable to Owner Designated Representative if it provides a workable arrangement for reviewing and processing the required submittals.
- C. Vendor/Contractor's Schedule of Values will be acceptable to Owner Designated Representative as to form and substance if it provides a reasonable allocation of the contract price to component parts of the work.

#### 6.16. CHANGES IN THE WORK; CLAIMS:

- A. Authorized Changes in the Work:
  - 1. Without invalidating the Contract and without notice to any surety, Owner may, at any time or from time to time, order additions, deletions, or revisions in the work by a Change Order. Upon receipt of any such document, Vendor/Contractor shall promptly proceed with the work involved which will be performed under the applicable conditions of the Contract Documents (except as otherwise specifically provided).
  - 2. All Owner ordered Change Orders will be subject to approval as specified under the provisions of section 218.755, F.S. and as stipulated in the Contract Agreement attached herein.
  - 3. If Owner and Vendor/Contractor are unable to agree on entitlement to, or on the amount or extent, if any, of an adjustment in the contract price or contract times, or both, that should be allowed as a result of a change order, a claim may be made therefor as provided in the Paragraph titled: "CLAIMS" below.
- B. Unauthorized Changes in the Work: Vendor/Contractor shall not be entitled to an increase in the contract price or an extension of the contract times with respect to any work performed that is not required by the Contract Documents as amended, modified, or supplemented, except in the case of an emergency as stated in Paragraph titled "EMERGENCIES" above, or in the case of uncovering work as stated in Paragraph titled "UNCOVERING WORK", below.
- C. Execution of Change Orders:
  - 1. Owner and Vendor/Contractor shall execute appropriate change orders recommended by Owner Designated Representative covering:
    - a. Changes in the work which are: (i) ordered by Owner pursuant to Paragraph titled "AUTHORIZED CHANGED IN THE WORK" above, (ii) required because of acceptance of

- defective work pursuant to Paragraph titled "ACCEPTANCE OF DEFECTIVE WORK", below or Owner's correction of defective work pursuant to Paragraph titled "OWNER MAY CORRECT DEFECTIVE WORK" , below or (iii) agreed to by the parties;
- b. Changes in the contract price or contract times which are agreed to by the parties, including any undisputed sum or amount of time for work actually performed in accordance with a change order; and
  - c. Changes in the contract price or contract times which embody the substance of any written decision rendered by Owner Designated Representative pursuant to Section titled "TESTS AND INSPECTIONS: CORRECTION, REMOVAL/ACCEPTANCE OF DEFECTIVE WORK", below ; provided that, in lieu of executing any such Change Order, an appeal may be taken from any such decision in accordance with the provisions of the Contract Documents and applicable laws and regulations, but during any such appeal, Vendor/Contractor shall carry on the work and adhere to the Progress Schedule as provided in Section titled "STARTING THE WORK", above.
2. The contract price constitutes the total compensation payable to the Vendor/Contractor for performing the work. All duties, responsibilities and obligations assigned to or undertaken by the Vendor/Contractor shall be at his expense without change in the contract price. The Contract Price may only be changed by a change order. Any claim for an increase in the Contract Price shall be in writing and delivered to the Owner Designated Representative within fifteen (15) days of the occurrence of the event giving rise to the claim. All claims for adjustment in the contract price shall be determined by the Owner Designated Representative. Any change in the contract price shall be incorporated in a change order.
- D. Notification to Surety: If notice of any change affecting the general scope of the work or the provisions of the Contract Documents (including, but not limited to, contract price or contract times) is required by the provisions of any bond to be given to a surety, the giving of any such notice will be Vendor/Contractor's responsibility. The amount of each applicable bond will be adjusted to reflect the effect of any such change.
- E. Claims:
1. Chief Procurement Officer's Decision Required: All claims, except those waived pursuant to Paragraph titled "WAIVER OF CLAIMS", below, shall be referred to the Chief Procurement Officer for decision. A decision by the Chief Procurement Officer shall be required as a condition precedent to any exercise by Owner or Vendor/Contractor of any rights or remedies either may otherwise have under Paragraph titled "OWNER MAY CORRECT DEFECTIVE WORK", below or by laws and regulations in respect of such claims.
  2. Notice: Written notice stating the general nature of each claim shall be delivered by the claimant to the Chief Procurement Officer and the other party to the Contract promptly (but in no event later than thirty (30) days) after the start of the event giving rise thereto. The

responsibility to substantiate a claim shall rest with the party making the claim. Notice of the amount or extent of the claim, with supporting data shall be delivered to the Chief Procurement Officer and the other party to the Contract within sixty (60) days after the start of such event (unless the Chief Procurement Officer allows additional time for claimant to submit additional or more accurate data in support of such claim). A claim for an adjustment in contract price shall be prepared in accordance with the provisions of Paragraph titled "CHANGE OF CONTRACT PRICE", above. A claim for an adjustment in Contract Time shall be prepared in accordance with the provisions of Paragraph titled "CHANGE OF CONTRACT TIMES". Each claim shall be accompanied by claimant's written statement that the adjustment claimed is the entire adjustment to which the claimant believes it is entitled as a result of said event. The opposing party shall submit any response to the Chief Procurement Officer and the claimant within thirty (30) days after receipt of the claimant's last submittal (unless the Chief Procurement Officer allows additional time).

3. Chief Procurement Officer's Action: Chief Procurement Officer will review each claim and, within thirty (30) days after receipt of the last submittal of the claimant or the last submittal of the opposing party, if any, take one (1) of the following actions in writing:
  - a. Deny the claim in whole or in part,
  - b. Approve the claim, or
  - c. Notify the parties that the Chief Procurement Officer is unable to resolve the claim if, in the Chief Procurement Officer's sole discretion, it would be inappropriate for the Chief Procurement Officer to do so. For purposes of further resolution of the claim, such notice shall be deemed a denial.
4. In the event that Chief Procurement Officer does not take action on a claim within said thirty (30) days, the claim shall be deemed denied.
5. Chief Procurement Officer's written action or denial pursuant to Paragraphs 3. and 4., above will be final and binding upon Owner and Vendor/Contractor, unless Owner or Vendor/Contractor invoke the dispute resolution procedure set forth in Section titled "DISPUTE RESOLUTION" within thirty (30) days of such action or denial.
6. No claim for an adjustment in contract price or contract times will be valid if not submitted in accordance with the provisions stated in Section titled "CHANGE OF CONTRACT PRICE; CHANGE OF CONTRACT TIMES" .

## 6.17. COST OF THE WORK; ALLOWANCES; UNIT PRICE WORK

### A. Cost of the Work:

1. Costs Included: The term cost of the work means the sum of all costs, except those excluded according to Section titled "COSTS EXCLUDED" below, necessarily incurred and paid by

Vendor/Contractor in the proper performance of the work. When the value of any work covered by a change order or when a claim for an adjustment in contract price is determined on the basis of cost of the work, the costs to be reimbursed to Vendor/Contractor will be only those additional or incremental costs required because of the change in the work or because of the event giving rise to the claim. Except as otherwise may be agreed to in writing by Owner, such costs shall be in amounts no higher than those prevailing in the locality of the project, shall include only the following items, and shall not include any of the costs itemized in Section titled "COSTS EXCLUDED".

- a. Payroll costs for employees in the direct employ of Vendor/Contractor in the performance of the work under schedules of job classifications agreed upon by Owner and Vendor/Contractor. Such employees shall include, without limitation, superintendents, foremen, and other personnel employed full time at the site. Payroll costs for employees not employed full time on the work shall be apportioned on the basis of their time spent on the work. Payroll costs shall include, but not be limited to, salaries and wages plus the cost of fringe benefits, which shall include Social Security contributions, unemployment, excise, and payroll taxes, workers' compensation, health and retirement benefits, bonuses, sick leave, vacation and holiday pay applicable thereto. The expenses of performing work outside of regular working hours, on Saturday, Sunday, or legal holidays, shall be included in the above to the extent authorized by Owner.
- b. Cost of all materials and equipment furnished and incorporated in the work, including costs of transportation and storage thereof, and suppliers' field services required in connection therewith. All cash discounts shall accrue to Vendor/Contractor unless Owner deposits funds with Vendor/Contractor with which to make payments, in which case the cash discounts shall accrue to Owner. All trade discounts, rebates and refunds and returns from sale of surplus materials and equipment shall accrue to Owner, and Vendor/Contractor shall make provisions so that they may be obtained.
- c. Payments made by Vendor/Contractor to subcontractors for work performed by subcontractors. If required by Owner, Vendor/Contractor shall obtain competitive bids from subcontractors acceptable to Owner and Vendor/Contractor and shall deliver such bids to Owner, who will then determine, with the advice of Owner Designated Representative, which bids, if any, will be acceptable. If any subcontract provides that the subcontractor is to be paid on the basis of cost of the work plus a fee, the subcontractor's cost of the work and fee shall be determined in the same manner as Vendor/Contractor's cost of the work and fee as provided in this Section titled "COST OF THE WORK".

- d. Costs of special consultants (including but not limited to engineers, architects, testing laboratories, surveyors, attorneys, and accountants) employed for services specifically related to the work.
- e. Supplemental costs including the following:
  - i. The proportion of necessary transportation, travel, and subsistence expenses of Vendor/Contractor's employees incurred in discharge of duties connected with the work.
  - ii. Cost, including transportation and maintenance, of all materials, supplies, equipment, machinery, appliances, office, and temporary facilities at the site, and hand tools not owned by the workers, which are consumed in the performance of the work, and cost, less market value, of such items used but not consumed which remain the property of Vendor/Contractor.
  - iii. Rentals of all construction equipment and machinery, and the parts thereof whether rented from Vendor/Contractor or others in accordance with rental agreements approved by Owner with the advice of the Owner Designated Representative, and the costs of transportation, loading, unloading, assembly, dismantling, and removal thereof. All such costs shall be in accordance with the terms of said rental agreements. The rental of any such equipment, machinery, or parts shall cease when the use thereof is no longer necessary for the work.
  - iv. Sales, consumer, use, and other similar taxes related to the work, and for which Vendor/Contractor is liable, imposed by laws and regulations.
  - v. Deposits lost for causes other than negligence of Vendor/Contractor, any subcontractor, or anyone directly or indirectly employed by any of them or for whose acts any of them may be liable, and royalty payments and fees for permits and licenses.
  - vi. Losses and damages (and related expenses) caused by damage to the work, not compensated by insurance or otherwise, sustained by Vendor/Contractor in connection with the performance of the work (except losses and damages within the deductible amounts of property insurance established in accordance with the Contract Documents), provided such losses and damages have resulted from causes other than the negligence of Vendor/Contractor, any subcontractor, or anyone directly or indirectly employed by any of them or for whose acts any of them may be liable. Such losses shall include settlements made with the written consent and approval of Owner. No such losses, damages, and expenses shall be included in the cost of the work for the purpose of determining Vendor/Contractor's fee.
  - vii. The cost of utilities, fuel, and sanitary facilities at the site.

- viii. Minor expenses such as telegrams, long distance telephone calls, telephone service at the site, expressages, and similar petty cash items in connection with the work.
  - ix. Vendor/Contractor is required by the Contract Documents to purchase and maintain all bonds and insurance.
2. Costs Excluded: The term cost of the work shall not include any of the following items:
- a. Payroll costs and other compensation of Vendor/Contractor's officers, executives, principals (of partnerships and sole proprietorships), general managers, safety managers, engineers, architects, estimators, attorneys, auditors, accountants, procurement and contracting agents, expeditors, timekeepers, clerks, and other personnel employed by Vendor/Contractor, whether at the site or in Vendor/Contractor's principal or branch office for general administration of the work and not specifically included in the agreed upon schedule of job classifications referred to in Paragraph 1. (in this section) or specifically covered by Paragraph 1. d. (in this section), all of which are to be considered administrative costs covered by the Vendor/Contractor's fee.
    - i. Expenses of Vendor/Contractor's principal and branch offices other than Vendor/Contractor's office at the site.
    - ii. Any part of Vendor/Contractor's capital expenses, including interest on Vendor/Contractor's capital employed for the work and charges against Vendor/Contractor for delinquent payments.
    - iii. Costs due to the negligence of Vendor/Contractor, any subcontractor, or anyone directly or indirectly employed by any of them or for whose acts any of them may be liable, including but not limited to, the correction of defective work, disposal of materials or equipment wrongly supplied, and making good any damage to property.
    - iv. Other overhead or general expense costs of any kind and the costs of any item not specifically and expressly included in Paragraphs 1. and 2. (in this section).
3. Vendor/Contractor's Fee: When all the work is performed on the basis of cost-plus, Vendor/Contractor's fee shall be determined as set forth in the Agreement. When the value of any work covered by a change order or when a claim for an adjustment in contract price is determined on the basis of cost of the work, Vendor/Contractor's fee shall be determined as set forth in Section titled: "CHANGE OF CONTRACT PRICE; CHANGE OF CONTRACT TIMES" Paragraph titled: "VENDOR/CONTRACTOR'S FEE".
4. Documentation: Whenever the cost of the work for any purpose is to be determined pursuant to Paragraph 1.(in this section), Vendor/Contractor will establish and maintain records thereof in accordance with generally accepted accounting practices and submit in a

form acceptable to Owner Designated Representative an itemized cost breakdown together with supporting data.

B. Allowances:

1. It is understood that Vendor/Contractor has included in the contract price all allowances so named in the Contract Documents and shall cause the work so covered to be performed for such sums and by such persons or entities as may be acceptable to Owner and Engineer.
2. Cash Allowances:
  - a. Vendor/Contractor agrees that:
    - i. The cash allowances include the cost to Vendor/Contractor (less any applicable trade discounts) of materials and equipment required by the allowances to be delivered at the site, and all applicable taxes; and
    - ii. Vendor/Contractor's costs for unloading and handling on the site, labor, installation, overhead, profit, and other expenses contemplated for the cash allowances have been included in the Contract Price and not in the allowances, and no demand for additional payment on account of any of the foregoing will be valid.
3. Contingency Allowance: Vendor/Contractor agrees that a contingency allowance, if any, is for the sole use of Owner to cover unanticipated costs.
4. Prior to final payment, an appropriate change order will be issued as recommended by Engineer to reflect actual amounts due Vendor/Contractor on account of work covered by allowances, and the contract price shall be correspondingly adjusted.

C. Unit Price Work:

1. Where the Contract Documents provide that all or part of the work is to be unit price work, initially the contract price will be deemed to include for all unit price work an amount equal to the sum of the unit price for each separately identified item of unit price work times the estimated quantity of each item as indicated in the Agreement.
2. The estimated quantities of items of unit price work are not guaranteed and are solely for the purpose of comparison of bids and determining an initial contract price. Determinations of the actual quantities and classifications of unit price work performed by Vendor/Contractor will be made by Owner Designated Representative subject to the provisions stated in the Contract Documents.
3. Each unit price will be deemed to include an amount considered by Vendor/Contractor to be adequate to cover Vendor/Contractor's overhead and profit for each separately identified item.

## 6.18. CHANGE OF CONTRACT PRICE; CHANGE OF CONTRACT TIMES

### Change of Contract Price:

- A. The Contract Price may only be changed by a change order. Any claim for an adjustment in the Contract Price shall be based on written notice submitted by the party making the claim to the Owner Designated Representative and the Chief Procurement Officer to the Contract in accordance with Section titled "CHANGES IN THE WORK; CLAIMS" Paragraph titled "Claims" above .
- B. The value of any work covered by a change order or of any claim for an adjustment in the Contract Price will be determined as follows:
  1. Where the work involved is covered by unit prices contained in the Contract Documents, by application of such unit prices to the quantities of the items involved (subject to the provisions stated in Section titled: "COST OF THE WORK; ALLOWANCES; UNIT PRICE WORK" Paragraph titled: "UNIT PRICE WORK"; or
  2. Where the work involved is not covered by unit prices contained in the Contract Documents, but by a mutually agreed lump sum (which may include an allowance for overhead and profit not necessarily in accordance with above Section titled: COST OF THE WORK; ALLOWANCES; UNIT PRICE WORK" Paragraph titled "CASH ALLOWANCES"); or
  3. Where the work involved is not covered by unit prices contained in the Contract Documents and Agreement to a lump sum is not reached under above Section titled: "COST OF THE WORK; ALLOWANCES; UNIT PRICE WORK" Paragraph titled: "COST OF THE WORK" , on the basis of the cost of the work, plus a Vendor/Contractor's fee for overhead and profit as described in this Section, Paragraph titled "VENDOR/CONTRACTOR'S FEE", immediately below.
- C. Vendor/Contractor's Fee: The Vendor/Contractor's fee for overhead and profit shall be determined as follows:
  1. A mutually acceptable fixed fee; or
  2. If a fixed fee is not agreed upon, then a fee based on the following percentages of the various portions of the cost of the work:
    - a. For costs incurred under Paragraphs B.1. and B.2. (in this section), the Vendor/Contractor's fee shall be fifteen percent (15%);
    - b. For costs incurred under Paragraph B.3. (in this section) , the Vendor/Contractor's fee shall be five percent (5%);
    - c. Where one (1) or more tiers of Sub-Contracts are on the basis of cost of the work plus a fee and no fixed fee is agreed upon, the intent of Paragraph C.2.a. above (in this section) is that the subcontractor who actually performs the work, at whatever tier, will be paid

- a fee of fifteen percent (15%) of the costs incurred by such subcontractor under Paragraphs B.1 and B.2. (in this section) and that any higher tier subcontractor and Vendor/Contractor will each be paid a fee of five percent (5%) of the amount paid to the next lower tier subcontractor;
- d. No fee shall be payable on the basis of costs itemized under Section titled "COST OF THE WORK; ALLOWANCES; UNIT PRICE WORK" Paragraph titled "COST OF THE WORK", "COSTS INCLUDED" paragraph 1.A.4, 1.A.5 and 1.B.;
  - e. The amount of credit to be allowed by Vendor/Contractor to Owner for any change which results in a net decrease in cost will be the amount of the actual net decrease in cost plus a deduction in Vendor/Contractor's fee by an amount equal to five percent (5%) of such net decrease; and
  - f. When both additions and credits are involved in any one (1) change, the adjustment in Vendor/Contractor's fee shall be computed on the basis of the net change in accordance with above Paragraphs (in this section) C.2.a. through C.2.f., inclusive.
- D. In such case, the Vendor/Contractor will submit in the form prescribed by the Owner, an itemized cost breakdown together with supporting data. The amount of credit to be allowed by the Vendor/Contractor to the Owner for any such change which results in a net decrease in cost, will be the amount of the actual net decrease as determined by the Owner. When both additions and credits are involved in any one (1) change, the combined overhead and profit shall be figured on the basis of the net decrease, if any.

#### 6.19. CHANGE OF CONTRACT PRICE; CHANGE OF CONTRACT TIMES (continued)

- A. Change of Contract Times:
- 1. The Contract Times may only be changed by a change order. Any claim for an adjustment in the Contract Times shall be based on written notice submitted by the party making the claim to the Engineer and the other party to the Contract in accordance with the provisions of Section titled " CHANGES IN THE WORK; CLAIMS" paragraph titled "CLAIMS".
  - 2. Any adjustment of the contract times covered by a change order or any claim for an adjustment in the contract times will be determined in accordance with the provisions of this paragraph.
- B. Delays:
- 1. Where Vendor/Contractor is prevented from completing any part of the work within the contract times due to delay beyond the control of Vendor/Contractor, the contract times will be extended in an amount equal to the time lost due to such delay if a claim is made therefore as provided in Section titled "CHANGES IN THE WORK; CLAIMS, paragraph titled "CLAIMS". Delays beyond the control of Vendor/Contractor shall include, but not be limited

to, acts or neglect by Owner, acts or neglect of utility owners or other Vendor/Contractors performing other work, fires, floods, epidemics, abnormal weather conditions, or acts of God.

2. If Owner, Engineer, or other Vendor/Contractors or utility owners performing other work for Owner, or anyone for whom Owner is responsible, delays, disrupts, or interferes with the performance or progress of the work, then Vendor/Contractor shall be entitled to an equitable adjustment in the contract price or the contract times, or both.  
Vendor/Contractor's entitlement to an adjustment of the contract times is conditioned on such adjustment being essential to Vendor/Contractor's ability to complete the work within the contract times.
3. If Vendor/Contractor is delayed in the performance or progress of the work by fire, flood, epidemic, abnormal weather conditions, acts of God, acts or failures to act of utility owners not under the control of Owner, or other causes not the fault of and beyond control of Owner and Vendor/Contractor, then Vendor/Contractor shall be entitled to an equitable adjustment in contract times, if such adjustment is essential to Vendor/Contractor's ability to complete the work within the Contract Times. Such an adjustment shall be Vendor/Contractor's sole and exclusive remedy for the delays described in this paragraph.
  - a. Time Extensions for Delays Caused by Weather - Extensions of Contract Time for delays caused by the effects of inclement weather are justified only when inclement weather conditions or related adverse soil conditions prevent the Contractor from productively performing controlling items of work resulting in:
    - i. The Vendor/Contractor being unable to work at least fifty percent (50%) of the normal work day on the predetermined controlling work items; or
    - ii. The Vendor/Contractor must make major repairs to work damaged by weather, providing the damage was not attributable to a failure to perform or neglect by the Contractor.
    - iii. Vendor/Contractor must submit a written notice along with their updated Progress Schedule with their monthly progress payment request. If no monthly progress payment is being submitted for the month, then a written notice within thirty (30) days after occurrence of the event(s) giving rise to the weather delays must be submitted to the Owner, Engineer or designated person.
  - b. Project Manager/Inspector - Daily reports shall be maintained for all projects by the Project Manager/Inspector. This shall include weather conditions, working conditions, erosion control, and effects of weather on major work items identified on the progress schedule and general comments as a minimum.

- c. Project Manager/Inspector - Daily reports shall be maintained for all projects by the Project Manager/Inspector. This shall include weather conditions, working conditions, erosion control, and effects of weather on major work items identified on the progress schedule and general comments as a minimum.
- d. Weather Delays for Projects - Time extensions will be granted on a contract day per delayed day.
  - i. The Contractor provides a schedule which identifies the intended work week, thus determining the scheduled work days and the controlling items of work. The initial progress schedule must be approved and agreed to by Owner, Engineer, or designated person and Contractor's Representative prior to the notice to proceed being issued and before any work has been performed and monthly when submitted with the pay request if any changes have occurred during the reporting period. No weather delays will be recognized before the Vendor/Contractor actually begins work or attempts to begin work in accordance with the approved project work schedule. Weather delays will be granted only during the authorized contract time period.
  - ii. The Owner, Engineer or designated person shall review the request and the daily reports and determine if these delays are authorized. A written response will be given to the Contractor/Vendor within five (5) business days after receipt of the request. The Chief Procurement Officer will be provided a copy of this letter and any related correspondence.
- 4. Owner, Engineer and the related entities of each of them shall not be liable to Vendor/Contractor for any claims, costs, losses, or damages (including but not limited to all fees and charges of engineers, architects, attorneys, and other professionals and all court or arbitration or other dispute resolution costs) sustained by Vendor/Contractor on or in connection with any other project or anticipated project.
- 5. Vendor/Contractor shall not be entitled to an adjustment in contract price or contract times for delays within the control of Vendor/Contractor. Delays attributable to and within the control of a subcontractor or supplier shall be deemed to be delays within the control of Vendor/Contractor.

#### 6.20. TESTS AND INSPECTIONS; CORRECTION, REMOVAL/ACCEPTANCE OF DEFECTIVE WORK:

- A. Notice of Defects: Prompt notice of all defective work of which Owner or Engineer has actual knowledge will be given to Vendor/Contractor. All defective work may be rejected, corrected, or accepted as provided in this Paragraph.

- B. Access to Work: Owner, Engineer, their consultants and other representatives and personnel of Owner, independent testing laboratories, and governmental agencies with jurisdictional interests will have access to the site and the work at reasonable times for their observation, inspecting, and testing. Vendor/Contractor shall provide them proper and safe conditions for such access and advise them of Vendor/Contractor's site safety procedures and programs so that they may comply therewith as applicable.
- C. Tests and Inspections:
1. Vendor/Contractor shall give Engineer timely notice of readiness of the work for all required inspections, tests, or approvals and shall cooperate with inspection and testing personnel to facilitate required inspections or tests.
  2. Owner shall employ and pay for the services of an independent testing laboratory to perform all inspections, tests, or approvals required by the Contract Documents except:
    - a. For inspections, tests, or approvals covered by Paragraphs D. and E. below;
    - b. That costs incurred in connection with tests or inspections conducted pursuant to Paragraph C.2. shall be paid according to Paragraph E.; and
    - c. As otherwise specifically provided in the Contract Documents.
  3. If laws or regulations of any public body having jurisdiction require any work (or part thereof) specifically to be inspected, tested, or approved by an employee or other representative of such public body, Vendor/Contractor shall assume full responsibility for arranging and obtaining such inspections, tests, or approvals, pay all costs in connection therewith, and furnish Owner Designated Representative the required certificates of inspection or approval.
  4. Vendor/Contractor shall be responsible for arranging and obtaining and shall pay all costs in connection with any inspections, tests, or approvals required for Owner's and Owner Designated Representative's acceptance of materials or equipment to be incorporated in the work; or acceptance of materials, mix designs, or equipment submitted for approval prior to Vendor/Contractor's purchase thereof for incorporation in the work. Such inspections, tests, or approvals shall be performed by organizations acceptable to Owner and Owner Designated Representative.
  5. If any work (or the work of others) that is to be inspected, tested, or approved is covered by Vendor/Contractor without written concurrence of Owner Designated Representative, it must, if requested by Owner Designated Representative, be uncovered for observation.
  6. Uncovering work as provided in Paragraph D. shall be at Vendor/Contractor's expense unless Vendor/Contractor has given Engineer timely notice of Vendor/Contractor's intention

to cover the same and Engineer has not acted with reasonable promptness in response to such notice.

7. Periodic inspections will be held throughout the work at the discretion of the Owner and Engineer to verify progress and compliance to Contract Documents, pay requests and general quality control.
8. Pre-final inspections are held for the purpose of substantiating completion of the work and preparing a punch-list of any deficiencies or corrections to be made. Pre-finals should be made with a representative of the Vendor/Contractor, Owner Designated Representative and Owner.
9. Final inspections will be held prior to acceptance in order to verify that all corrections and/or deficiencies have been performed or resolved and such inspection shall be mandatory prior to approval of final pay request. Finals shall be made with a representative of the Vendor/Contractor, Engineer and Owner.

D. Uncovering Work:

1. If any work is covered contrary to the written request of Owner Designated Representative, it must, if requested by Owner Designated Representative, be uncovered for Owner Designated Representative's observation and replaced at Vendor/Contractor's expense.
2. If Owner Designated Representative considers it necessary or advisable that covered work be observed by Owner Designated Representative or inspected or tested by others, Vendor/Contractor, at Owner Designated Representative's request, shall uncover, expose, or otherwise make available for observation, inspection, or testing as Owner Designated Representative may require, that portion of the work in question, furnishing all necessary labor, material, and equipment.
3. If it is found that the uncovered work is defective, Vendor/Contractor shall pay all claims, costs, losses, and damages (including but not limited to all fees and charges of engineers, architects, attorneys, and other professionals and all court or arbitration or other dispute resolution costs) arising out of or relating to such uncovering, exposure, observation, inspection, and testing, and of satisfactory replacement or reconstruction (including but not limited to all costs of repair or replacement of work of others); and Owner shall be entitled to an appropriate decrease in the contract price. if the parties are unable to agree as to the amount thereof, Owner may make a claim therefore as provided in Section titled "CHANGES IN THE WORK; CLAIMS" paragraph titled "CLAIMS".
4. If, the uncovered work is not found to be defective, and there are no related inspection requirements in the contract documents, Vendor/Contractor shall be allowed an increase in the contract price or an extension of the contract times, or both, directly attributable to such uncovering, exposure, observation, inspection, testing, replacement, and

reconstruction. If the parties are unable to agree as to the amount or extent thereof, Vendor/Contractor may make a claim therefore as provided in Section titled "CHANGES IN THE WORK; CLAIMS" paragraph titled "CLAIMS".

- E. Owner Designated Representative May Stop the Work: If the work is defective, or Vendor/Contractor fails to supply sufficient skilled workers or suitable materials or equipment, or fails to perform the work in such a way that the completed work will conform to the contract documents, Owner may order Vendor/Contractor to stop the work, or any portion thereof, until the cause for such order has been eliminated; however, this right of Owner to stop the work shall not give rise to any duty on the part of Owner to exercise this right for the benefit of Vendor/Contractor, any subcontractor, any supplier, any other individual or entity, or any surety for, or employee or agent of any of them.
- F. Correction or Removal of Defective Work:
1. Promptly after receipt of notice, Vendor/Contractor shall correct all defective work, whether or not fabricated, installed, or completed, or, if the work has been rejected by Owner Designated Representative, remove it from the project and replace it with work that is not defective. Vendor/Contractor shall pay all claims, costs, losses, and damages (including but not limited to all fees and charges of engineers, architects, attorneys, and other professionals and all court or arbitration or other dispute resolution costs) arising out of or relating to such correction or removal (including but not limited to all costs of repair or replacement of work of others).
  2. When correcting defective work under the terms of this paragraph or the paragraph below, Vendor/Contractor shall take no action that would void or otherwise impair Owner's special warranty and guarantee, if any, on said work.
- G. Correction Period:
1. If within one (1) year after the date of substantial completion (or such longer period of time as may be prescribed by the terms of any applicable special guarantee required by the Contract Documents) or by any specific provision of the contract documents, any work is found to be defective, or if the repair of any damages to the land or areas made available for Vendor/Contractor's use by Owner or permitted by laws and regulations as contemplated in the Contract Documents is found to be defective, Vendor/Contractor shall promptly, without cost to Owner and in accordance with Owner's written instructions:
    - a. Repair such defective land or areas; or
    - b. Correct such defective work; or
    - c. If the defective work has been rejected by Owner, remove it from the project and replace it with work that is not defective, and

- d. Satisfactorily correct or repair or remove and replace any damage to other work, to the work of others or other land or areas resulting therefrom.
  2. If Vendor/Contractor does not promptly comply with the terms of Owner's written instructions, or in an emergency where delay would cause serious risk of loss or damage, Owner may have the defective work corrected or repaired or may have the rejected work removed and replaced. All claims, costs, losses, and damages (including but not limited to all fees and charges of engineers, architects, attorneys, and other professionals and all court or arbitration or other dispute resolution costs) arising out of or relating to such correction or repair or such removal and replacement (including but not limited to all costs of repair or replacement of work of others) will be paid by Vendor/Contractor.
  3. In special circumstances where a particular item of equipment is placed in continuous service before Substantial Completion of all the work, the correction period for that item may start to run from an earlier date if so provided in the specifications.
  4. Where defective work (and damage to other work resulting therefrom) has been corrected or removed and replaced under above paragraph F, the correction period hereunder with respect to such work will be extended for an additional period of one (1) year after such correction or removal and replacement has been satisfactorily completed.
  5. Vendor/Contractor's obligations under above paragraph F. are in addition to any other obligation or warranty. The provisions of Paragraph F. shall not be construed as a substitute for or a waiver of the provisions of any applicable statute of limitation or repose.
- H. Acceptance of Defective Work: If, instead of requiring correction or removal and replacement of defective work, Owner (and, prior to Owner Designated Representative's recommendation of final payment, Owner Designated Representative) prefers to accept it, Owner may do so. Vendor/Contractor shall pay all claims, costs, losses, and damages (including but not limited to all fees and charges of engineers, architects, attorneys, and other professionals and all court or arbitration or other dispute resolution costs) attributable to Owner's evaluation of and determination to accept such defective work (such costs to be approved by Owner Designated Representative as to reasonableness) and the diminished value of the work to the extent not otherwise paid by Vendor/Contractor pursuant to this sentence. If any such acceptance occurs prior to Owner Designated Representative's recommendation of final payment, a change order will be issued incorporating the necessary revisions in the contract documents with respect to the work, and Owner shall be entitled to an appropriate decrease in the contract price, reflecting the diminished value of work so accepted. If the parties are unable to agree as to the amount thereof, Owner may make a claim therefore as provided in Section titled "CHANGES IN THE WORK; CLAIMS", paragraph titled "CLAIMS". If the acceptance occurs after such recommendation, an appropriate amount will be paid by Vendor/Contractor to Owner.
- I. Owner May Correct Defective Work:

1. If Vendor/Contractor fails within a reasonable time after written notice from Owner Designated Representative to correct defective work or to remove and replace rejected work as required by Owner Designated Representative in accordance with Paragraph F., or if Vendor/Contractor fails to perform the work in accordance with the contract documents, or if Vendor/Contractor fails to comply with any other provision of the Contract Documents, Owner may, after seven (7) days written notice to Vendor/Contractor, correct or remedy any such deficiency.
2. In exercising the rights and remedies under this paragraph, Owner shall proceed expeditiously. In connection with such corrective or remedial action, Owner may exclude Vendor/Contractor from all or part of the site, take possession of all or part of the work and suspend Vendor/Contractor's services related thereto, take possession of Vendor/Contractor's tools, appliances, construction equipment and machinery at the site, and incorporate in the work all materials and equipment stored at the site or for which Owner has paid Vendor/Contractor but which are stored elsewhere. Vendor/Contractor shall allow Owner, Owner's Designated representatives, agents and employees, Owner's other Vendor/Contractors, and Engineer and Engineer's consultants access to the site to enable Owner to exercise the rights and remedies under this paragraph.
3. All claims, costs, losses, and damages (including but not limited to all fees and charges of engineers, architects, attorneys, and other professionals and all court or arbitration or other dispute resolution costs) incurred or sustained by Owner in exercising the rights and remedies under Paragraph I. will be charged against Vendor/Contractor, and a change order will be issued incorporating the necessary revisions in the Contract Documents with respect to the work; and Owner shall be entitled to an appropriate decrease in the contract price. If the parties are unable to agree as to the amount of the adjustment, Owner may make a claim therefore as provided in Section titled "CHANGES IN THE WORK; CLAIMS", paragraph titled "CLAIMS. Such claims, costs, losses and damages will include but not be limited to all costs of repair, or replacement of work of others destroyed or damaged by correction, removal, or replacement of Vendor/Contractor's defective work.
4. Vendor/Contractor shall not be allowed an extension of the contract times because of any delay in the performance of the work attributable to the exercise by Owner of Owner's rights and remedies under Paragraph I.

#### **6.21. PAYMENTS TO CONTRACTOR AND COMPLETION**

- A. Schedule of Values: The Schedule of Values established as provided in Section titled "STARTING THE WORK", paragraph A. 2. c. will serve as the basis for progress payments and will be incorporated into a form of application for payment acceptable to Owner Designated Representative. Progress payments on account of unit price work will be based on the number of units completed.

**B. Progress Payments:**

**1. Application for Payments:**

- a. At least twenty (20) business days before the date established in the Agreement for each progress payment (but not more often than once a month), Vendor/Contractor shall submit to Owner Designated Representative for review an application for payment filled out and signed by vendor/contractor covering the work completed as of the date of the application and accompanied by such supporting documentation as is required by the contract documents. If payment is requested on the basis of materials and equipment not incorporated in the work but delivered and suitably stored at the site or at another location agreed to in writing, the application for payment shall also be accompanied by a bill of sale, invoice, or other documentation warranting that Owner has received the materials and equipment all of which must be satisfactory to Owner.
- b. Beginning with the second application for payment, each application shall include an affidavit of Vendor/Contractor stating that all previous progress payments received on account of the work have been applied on account to discharge Vendor/Contractor's legitimate obligations associated with prior applications for payment.
- c. The amount of retainage with respect to progress payments will be as stipulated in Article 5.02 of the construction agreement.
- d. All progress payments will be subject to withholding and payment of retainage as specified under the provisions of sec. 218.735, F.S. and as stipulated in the Contract Agreement attached herein. Payment requests will be processed within the time periods established by applicable provisions of the Florida Prompt Payment Act, Part VII, sec. 218.735, F.S.

**2. Review of Applications:**

- a. Owner Designated Representative will, within five (5) business days after receipt of each application for payment, either indicate in writing a recommendation of payment and present the application to Owner or return the application to Vendor/Contractor indicating in writing Owner Designated Representative's reasons for refusing to recommend payment. In the latter case, Vendor/Contractor may make the necessary corrections and resubmit the application.
- b. Owner Designated Representative's recommendation of any payment requested in an application for payment will constitute a representation by Owner Designated Representative to Owner, based on Owner Designated Representative's observations on the site of the executed work as an experienced and qualified design professional and on Owner Designated Representative's review of the application for payment and the

accompanying data and schedules, that to the best of Owner Designated Representative's knowledge, information and belief:

- i. The work has progressed to the point indicated;
  - ii. The quality of the work is generally in accordance with the Contract Documents (subject to an evaluation of the work as a functioning whole prior to or upon substantial completion, to the results of any subsequent tests called for in the Contract Documents, to a final determination of quantities and classifications for unit price work under above Section titled: "COST OF THE WORK; ALLOWANCES; UNIT PRICE WORK",, and to any other qualifications stated in the recommendation); and
  - iii. The conditions precedent to Vendor/Contractor's being entitled to such payment appear to have been fulfilled in so far as it is Owner Designated Representative's responsibility to observe the work.
- c. By recommending any such payment Owner Designated Representative will not thereby be deemed to have represented that:
- i. Inspections made to check the quality or the quantity of the work as it has been performed have been exhaustive, extended to every aspect of the work in progress, or involved detailed inspections of the work beyond the responsibilities specifically assigned to Owner Designated Representative in the Contract Documents; or
  - ii. That there may not be other matters or issues between the parties that might entitle Vendor/Contractor to be paid additionally by Owner or entitle Owner to withhold payment to Vendor/Contractor.
- d. Neither Owner Designated Representative's review of Vendor/Contractor's work for the purposes of recommending payments nor Owner Designated Representative's recommendation of any payment, including final payment, will impose responsibility on Owner Designated Representative:
- i. To supervise, direct, or control the work, or
  - ii. For the means, methods, techniques, sequences, or procedures of construction, or the safety precautions and programs incident thereto, or
  - iii. For Vendor/Contractor's failure to comply with laws and regulations applicable to Vendor/Contractor's performance of the work, or
  - iv. To make any examination to ascertain how or for what purposes Vendor/Contractor has used the moneys paid on account of the contract price, or
  - v. To determine that title to any of the work, materials, or equipment has passed to Owner free and clear of any liens.

- e. Owner Designated Representative may refuse to recommend the whole or any part of any payment if, in Owner Designated Representative's opinion, it would be incorrect to make the representations to Owner stated in Paragraph 2.b., above. Owner Designated Representative may also refuse to recommend any such payment or, because of subsequently discovered evidence or the results of subsequent inspections or tests, revise or revoke any such payment recommendation previously made, to such extent as may be necessary in Owner Designated Representative's opinion to protect Owner from loss because:
  - i. The work is defective, or completed work has been damaged, requiring correction or replacement;
  - ii. The contract price has been reduced by change orders;
  - iii. Owner has been required to correct defective work or complete work in accordance with above Paragraph titled "Owner May Correct Defective Work" in Section titled: "TESTS AND INSPECTIONS; CORRECTION, REMOVAL/ACCEPTANCE OF DEFECTIVE WORK"; or
  - iv. Owner Designated Representative has actual knowledge of the occurrence of any of the events enumerated in below Paragraph titled "Owner May Terminate for Cause: " in Section titled: "TERMINATION AND SUSPENSION OF WORK".
- 3. Payment Becomes Due: The application for payment, and all of the required Federal and State submittals, with the Owner Designated Representative's recommendations will be presented to the Owner for consideration. If the Owner finds the application for payment acceptable, the recommended amount, less any reduction under the provisions of Paragraph B. 2. (in this section), will become due twenty-five (25) business days after the application for payment is presented to the Owner, and the Owner will make payment to the Vendor/Contractor.
- 4. Payment to Vendor/Contractor by Electronic Payment Solution: ACH (Direct Deposit): If the Vendor/Contractor is enrolled in the County's ACH electronic payment solution, all payments will be made using the direct deposit which may or may not include a pre-note transaction. The Vendor/Contractor's bank account information will remain confidential to the extent provided by law and necessary to make direct deposit payments. Once the County has approved payment, an electronic remittance advice will be sent to the Vendor/Contractor via e-mail.
- 5. Reduction in Payment:
  - a. Owner may refuse to make payment of the full amount recommended by Owner Designated Representative because:

- i. Claims have been made against Owner on account of Vendor/Contractor's performance or furnishing of the work;
  - ii. Liens have been filed in connection with the work, except where Vendor/Contractor has delivered a specific bond satisfactory to Owner to secure the satisfaction and discharge of such liens;
  - iii. The Vendor/Contractor's performance or furnishing of the work is inconsistent with funding agency requirements;
  - iv. There are other items entitling Owner to a set off against the amount recommended; or
  - v. Owner has actual knowledge of the occurrence of any of the events enumerated in Paragraphs B. 2. e. i. through B. 2. e. iii. (in this section) or below Paragraph titled "Owner May Terminate for Cause" in Section titled: "TERMINATION AND SUSPENSION OF WORK."
- b. If Owner refuses to make payment of the full amount recommended by Owner Designated Representative, Owner will (in no case more than twenty (20) business days after receipt and twenty-five (25) business days for payment) give Vendor/Contractor immediate written notice (with a copy to Engineer) stating the reasons for such action and promptly pay Vendor/Contractor any amount remaining after deduction of the amount so withheld. Owner shall promptly pay Vendor/Contractor the amount so withheld, or any adjustment thereto agreed to by Owner and Vendor/Contractor, when Vendor/Contractor corrects to Owner's satisfaction the reasons for such action.
  - c. If it is subsequently determined that Owner's refusal of payment was not justified, the amount wrongfully withheld shall be treated as an amount due as determined by Paragraph B. 3. (in this section).
  - d. No payments will be made that would deplete the retainage, place in escrow any funds that are required for retainage, or invest the retainage for the benefit of the Vendor/Contractor.
- C. Vendor/Contractor's Warranty of Title:
- 1. Vendor/Contractor warrants and guarantees that title to all work, materials, and equipment covered by any application for payment, whether incorporated in the project or not, will pass to Owner prior to the making of the application for payment, free and clear of all liens, claims, security interests and encumbrances; and that no work, materials or equipment covered by an application for payment will have been acquired by the Vendor/Contractor or by any other person performing the work at the site or furnishing materials and equipment for the project subject to an Agreement under which an interest therein or encumbrance

thereon is retained by the seller or otherwise imposed by the Vendor/Contractor or such other person.

2. In compliance with the above and as verification of the Vendor/Contractor's compliance with applicable provisions of the Florida Prompt Payment Act, sec. 218.735, F.S., concerning payment to subcontractors and suppliers, the Vendor/Contractor, in addition to any other payment provisions set in this contract, shall prior to submission of the second application for payment, produce for the Owner evidence, in the form of releases of lien or subcontractor(s)/suppliers affidavits of payment received, that all subcontractors and suppliers have been paid any sum or sums then due within the time periods so specified. This reporting process shall be repeated following each succeeding payment to the Vendor/Contractor throughout the life of the Contract. A failure on the part of the Vendor/Contractor to provide the releases as required herein shall result in further progress or partial payments being withheld until the releases or payment affidavits are provided.

D. Partial Utilization:

1. Prior to Substantial Completion of all the work, Owner may use or occupy any substantially completed part of the work which has specifically been identified in the Contract Documents, or which Owner, Owner Designated Representative, and Vendor/Contractor agree constitutes a separately functioning and usable part of the work that can be used by Owner for its intended purpose without significant interference with Vendor/Contractor's performance of the remainder of the work, subject to the following conditions.
  - a. Owner at any time may request Vendor/Contractor in writing to permit Owner to use or occupy any such part of the work which Owner believes to be ready for its intended use and substantially complete. If and when Vendor/Contractor agrees that such part of the work is substantially complete, Vendor/Contractor will certify to Owner and Owner Designated Representative that such part of the work is substantially complete and request Owner Designated Representative to issue a certificate of substantial completion for that part of the work.
  - b. Vendor/Contractor at any time may notify Owner and Owner Designated Representative in writing that Vendor/Contractor considers any such part of the work ready for its intended use and is thus substantially complete and may request Owner Designated Representative to issue a certificate of substantial completion for that part of the work.
  - c. Within a reasonable time after either such request, Owner, Vendor/Contractor, and Owner Designated Representative shall make an inspection of that part of the work to determine its status of completion. If Owner Designated Representative does not consider that part of the work to be substantially complete, Owner Designated Representative will notify Owner and Vendor/Contractor in writing giving the reasons

therefore. If Owner Designated Representative considers that part of the work to be substantially complete, the provisions stated herein will apply with respect to certification of Substantial Completion of that part of the work and the division of responsibility in respect thereof and access thereto.

- d. No use or occupancy or separate operation of part of the work may occur prior to compliance with the requirements of the contract documents regarding property insurance.

E. Substantial Completion:

1. When Vendor/Contractor considers the entire work ready for its intended use Vendor/Contractor shall notify Owner and Owner Designated Representative in writing that the entire work is substantially complete (except for items specifically listed by Vendor/Contractor as incomplete) and request that the Owner issue a certificate of substantial completion.
2. Promptly after Vendor/Contractor's notification, Owner, Agency, Vendor/Contractor, and Owner Designated Representative shall make a pre-final inspection of the work to determine the status of completion. If Owner Designated Representative does not consider the work substantially complete, Owner Designated Representative will notify Vendor/Contractor in writing giving the reasons therefore.
3. If the Owner Designated Representative considers the work substantially complete, Owner Designated Representative will deliver to Owner a tentative certificate of substantial completion which shall fix the date of substantial completion. there shall be attached to the certificate a tentative list of items to be completed or corrected before final payment. Owner shall have seven (7) days after receipt of the tentative certificate during which to make written objection to Owner Designated Representative as to any provisions of the certificate or attached list. If, after considering such objections, Owner Designated Representative concludes that the work is not substantially complete, Owner Designated Representative will within fourteen (14) days after submission of the tentative certificate to Owner notify Vendor/Contractor in writing, stating the reasons therefore. If, after consideration of Owner's objections, Owner Designated Representative considers the work substantially complete, Owner Designated Representative will within said fourteen (14) days execute and deliver to Owner and Vendor/Contractor a definitive certificate of substantial completion (with a revised tentative list of items to be completed or corrected) reflecting such changes from the tentative certificate as Owner Designated Representative believes justified after consideration of any objections from Owner.
4. At the time of delivery of the tentative certificate of Substantial Completion, Owner Designated Representative will deliver to Owner and Vendor/Contractor a written recommendation as to division of responsibilities pending final payment between Owner

- and Vendor/Contractor with respect to security, operation, safety, and protection of the work, maintenance, heat, utilities, insurance, and warranties and guarantees. Unless Owner and Vendor/Contractor agree otherwise in writing and so inform Owner Designated Representative in writing prior to Owner Designated Representative's issuing the definitive certificate of substantial completion, Owner Designated Representative's aforesaid recommendation will be binding on Owner and Vendor/Contractor until final payment.
5. Owner shall have the right to exclude Vendor/Contractor from the site after the date of Substantial Completion subject to allowing Vendor/Contractor reasonable access to complete or correct items on the tentative list.
  - F. Final Inspection: Upon written notice from Vendor/Contractor that the entire work or an agreed portion thereof is complete, Owner Designated Representative will promptly make a final inspection with Owner, Agency, and Vendor/Contractor and will notify Vendor/Contractor in writing of all particulars in which this inspection reveals that the work is incomplete or defective. Vendor/Contractor shall immediately take such measures as are necessary to complete such work or remedy such deficiencies.

## 6.22. PAYMENTS TO CONTRACTOR AND COMPLETION (continued)

- A. Final Payment:
  1. Application for Payment:
    - a. After Vendor/Contractor has, in the opinion of Owner Designated Representative, satisfactorily completed all corrections identified during the final inspection and has delivered, in accordance with the contract documents, all maintenance and operating instructions, schedules, guarantees, bonds, certificates or other evidence of insurance certificates of inspection, marked up record documents, and other documents, Vendor/Contractor may make application for final payment following the procedure for progress payments.
    - b. The final application for payment shall be accompanied (except as previously delivered) by:
      - i. All documentation called for in the Contract Documents, including but not limited to the evidence of insurance required by above Section titled: "INSURANCE REQUIREMENTS" ;
      - ii. Consent of the surety, if any, to final payment;
      - iii. A list of all claims against Owner that Vendor/Contractor believes are unsettled; and
      - iv. Complete and legally effective releases or waivers (satisfactory to Owner) of all lien rights arising out of or liens filed in connection with the work.

- c. In lieu of the releases or waivers of liens specified in above Paragraph A. 1. b. iv. and as approved by Owner, Vendor/Contractor may furnish receipts or releases in full and an affidavit of Vendor/Contractor that: (i) the releases and receipts include all labor, services, material, and equipment for which a lien could be filed; and (ii) all payrolls, material and equipment bills, and other indebtedness connected with the work for which Owner or Owner's property might in any way be responsible have been paid or otherwise satisfied. If any subcontractor or supplier fails to furnish such a release or receipt in full, Vendor/Contractor may furnish a bond or other collateral satisfactory to Owner to indemnify Owner against any lien.
  2. Owner Designated Representative's Review of Application and Acceptance:
    - a. If, on the basis of Owner Designated Representative's observation of the work during construction and final inspection, and Owner Designated Representative's review of the final application for payment and accompanying documentation as required by the Contract Documents, Owner Designated Representative is satisfied that the work has been completed and Vendor/Contractor's other obligations under the Contract Documents have been fulfilled, Owner Designated Representative will, within ten (10) days after receipt of the final application for payment, indicate in writing Owner Designated Representative's recommendation of payment and present the application for payment to Owner for payment. At the same time Owner Designated Representative will also give written notice to Owner and Vendor/Contractor that the work is acceptable to the provisions as described in above Paragraph A titled "Final Payment" (in this section) . Otherwise, Owner Designated Representative will return the application for payment to Vendor/Contractor, indicating in writing the reasons for refusing to recommend final payment, in which case Vendor/Contractor shall make the necessary corrections and resubmit the application for payment.
  3. Payment Becomes Due: After the presentation to Owner of the application for payment and accompanying documentation to include all of the required Federal and State submittals, the Owner will, within the time periods established by applicable provisions of the Florida Prompt Payment Act, Part VII, sec. 218.735, F.S., pay the Vendor/Contractor the amount recommended by Owner Designated Representative, less any sum Owner is entitled to set off against Owner Designated Representative's recommendation, including but not limited to liquidated damages.
- B. Final Completion Delayed: If, through no fault of Vendor/Contractor, final completion of the work is significantly delayed, and if owner designated representative so confirms, owner shall, upon receipt of vendor/contractor's final application for payment (for work fully completed and accepted) and recommendation of Owner Designated Representative, and without terminating the Contract, make payment of the balance due for that portion of the work fully completed and accepted. If the remaining balance to be held by Owner for work not fully completed or

corrected is less than the retainage stipulated in the Agreement, and if bonds have been furnished as required in above Section titled "PERFORMANCE AND PAYMENT BOND", the written consent of the surety to the payment of the balance due for that portion of the work fully completed and accepted shall be submitted by Vendor/Contractor to Owner Designated Representative with the application for such payment. Such payment shall be made under the terms and conditions governing final payment, except that it shall not constitute a waiver of claims. The remaining balance of any sum included in the final application for payment but held by Owner for work not fully completed and accepted will become due when the work is fully completed and accepted.

C. Waiver of Claims: The making and acceptance of final payment will constitute:

1. A waiver of all claims by Owner against Vendor/Contractor, except claims arising from unsettled liens, from defective work appearing after final inspection pursuant to above Section titled "TESTS AND INSPECTIONS; CORRECTION, REMOVAL/ACCEPTANCE OF DEFECTIVE WORK", paragraph titled "CORRECTION OR REMOVAL OF DEFECTIVE WORK", from failure to comply with the contract documents or the terms of any special guarantees specified therein, or from Vendor/Contractor's continuing obligations under the contract documents; and
2. A waiver of all claims by Vendor/Contractor against Owner other than those previously made in accordance with the requirements herein and expressly acknowledged by Owner in writing as still unsettled.

D. Vendor/Contractor's Continuing Obligation: The Vendor/Contractor's obligation to perform the work and complete the work in accordance with the Contract Documents shall be absolute. Neither approval of any progress or final payment by the County, the issuance of Certificate of Completion, any payment by the County to the Vendor/Contractor under the contract documents, any use or occupancy of the work or any part thereof by the County, any act of acceptance by the County, any failure to do so, nor any correction of defective work by the County shall constitute an acceptance of work not in accordance with the contract documents.

1. Contract Closeout:

a. Pre-final and Final Inspections:

- i. Upon completion of work, Vendor/Contractor shall submit written certification that the Contract Documents have been reviewed, the work has been inspected by the Vendor/Contractor, and that the work is substantially complete in accordance with the contract document and ready for Engineer/Owner Designated Representative's inspection.
- ii. At this time the representatives of the Vendor/Contractor, Engineer/Owner Designated Representative's and Owner shall make a pre-final/substantial

completion inspection with reasonable promptness. If the work is complete or defective, Engineer/Owner Designated Representative will notify the Contractor to remedy these deficiencies by insurance of a pre-final punch-list.

- iii. Upon written notification from the Vendor/Contractor of substantial complete of the pre-final punch list items, the Engineer/Owner Designated Representative will coordinate the re-inspection of the work by conducting a final inspection. Representatives of the Contract, Engineer, and Owner Designated Representative shall be present for the final inspection.
  - iv. Vendor/Contractor shall submit the final signed and sealed As-Built drawings ten (10) days prior to the final inspection and provide all other submittals to the Engineer/Owner Designated Representative's that are required.
- b. Project Record Documents: The Vendor/Contractor shall maintain on site, one (1) set of the following record documents; recording actual revisions of the work commensurate with the construction progress:
- i. Contract Drawings
  - ii. Specifications
  - iii. Addenda
  - iv. Change Orders and other modification to the Contract
  - v. Reviewed (and approved) Shop Drawings and Product Data
  - vi. Permits
- c. Closeout Submittals: When the Engineer/Owner Designated Representative's has determined that the work is acceptable under the Contract Documents, and the contract is fully performed, the Vendor/Contractor shall prepare and submit his final applicable for payment to the Engineer/Owner Designated Representative's with the following:
- i. Contractor's Lien Waiver in the full amount of the contract sum.
  - ii. Lien waivers from all subcontractors and material suppliers who have furnished for the work under contract with the Contactor or subcontractor. The lien waivers shall be in the full amount of the Contract involved.
  - iii. Consent of Surety to final payment.
  - iv. Evidence of compliance with governing authorities.
  - v. Certifications of inspections from all required agencies and departments, as needed.
  - vi. Warranties and Maintenance Bond.

- vii. Confirmation from Florida Department of Environmental Protection the National Pollution Discharge Elimination System Notice of Termination (NOT) has been filed.
- viii. Any outstanding documentation and/or reports necessary to insure compliance with FDOT requirements.
- ix. As-Built documents prepared in accordance with the contract documents and signed and sealed by a professional surveyor and mapper, registered in the State of Florida and all other requirements as set forth in the contract documents.
- d. Performance Evaluation: At the end of the contract, the receiving Department will evaluate the successful Vendor/Contractor's performance. This evaluation will become public record.

### 6.23. TERMINATION AND SUSPENSION OF WORK

#### A. Termination for Default:

1. The County may, by written notice to the Vendor/Contractor, terminate this Contract for default in whole or in part (delivery orders, if applicable) if the Vendor/Contractor fails to:
  - a. Provide products or services that comply with the specifications herein or fails to meet the County's performance standards.
  - b. Deliver the supplies or to perform the services within the time specified in this Contract or any extension.
  - c. Make progress so as to endanger performance of this Contract.
  - d. Perform any of the other provisions of this Contract.
2. Prior to termination for default, the County will provide adequate written notice to the (Vendor/Contractor/Consultant) through the Chief Procurement Officer, Procurement Department, affording him/her the opportunity to cure the deficiencies or to submit a specific plan to resolve the deficiencies within ten (10) days (or the period specified in the notice) after receipt of the notice. Failure to adequately cure the deficiency shall result in termination action. Such termination may also result in suspension or debarment of the Vendor/Contractor in accordance with the County's Procurement Ordinance. The Vendor/Contractor and its sureties (if any) shall be liable for any damage to the County resulting from the Vendor/Contractor's default of the contract. This liability includes any increased costs incurred by the County in completing contract performance.
3. In the event of termination by the County for any cause, the Vendor/Contractor will have, in no event, any claim against the County for lost profits or compensation for lost opportunities. After a receipt of a termination notice and except as otherwise directed by the County the Vendor/Contractor shall:

- a. Stop work on the date and to the extent specified.
  - b. Terminate and settle all orders and subcontracts relating to the performance of the terminated work.
  - c. Transfer all work in process, completed work, and other materials related to the terminated work as directed by the County.
  - d. Continue and complete all parts of that work that have not been terminated.
4. If the Vendor/Contractor's failure to perform the Contract arises from causes beyond the control and without the fault or negligence of the Vendor/Contractor, the Contract shall not be terminated for default. Examples of such causes include (1) acts of God or the public enemy, (2) acts of a government in its sovereign capacity, (3) fires, (4) floods, (5) epidemics, (6) strikes and (7) unusually severe weather.
- B. Termination for Convenience: The County, by written notice, may terminate this Contract, in whole or in part, when it is in the County's interest. If this Contract is terminated, the County shall be liable only for goods or services delivered and accepted. The county notice of termination may provide the Vendor/Contractor thirty (30) days prior notice before it becomes effective. A termination for convenience may apply to individual delivery orders, purchase orders or to the Contract in its entirety.
- C. Vendor/Contractor May Stop Work or Terminate:
1. If, through no act or fault of Vendor/Contractor, (i) the work is suspended for more than ninety (90) consecutive days by Owner or under an order of court or other public authority, or (ii) Engineer fails to act on any application for payment within thirty (30) days after it is submitted, or (iii) Owner fails for thirty (30) days to pay Vendor/Contractor any sum finally determined to be due, then Vendor/Contractor may, upon seven (7) days written notice to Owner and Engineer, and provided Owner or Engineer do not remedy such suspension or failure within that time, terminate the Contract and recover from Owner.
  2. In lieu of terminating the Contract and without prejudice to any other right or remedy, if Engineer has failed to act on an application for payment within thirty (30) days after it is submitted, or Owner has failed for thirty (30) days to pay Vendor/Contractor any sum finally determined to be due, Vendor/Contractor may, seven (7) days after written notice to Owner and Engineer, stop the work until payment is made of all such amounts due Vendor/Contractor, including interest thereon. The provisions of this paragraph are not intended to preclude Vendor/Contractor from making a claim as described in above Section titled "CHANGES IN THE WORK; CLAIMS", paragraph titled "Claims", for an adjustment in contract price or contract times or otherwise for expenses or damage directly attributable to Vendor/Contractor's stopping the work as permitted by this paragraph.

- D. Owner May Suspend Work: Owner may suspend work at any time and without cause, for a period of not more than ninety (90) consecutive days by notice in writing to Vendor/Contractor and Engineer which will fix the date on which work will be resumed. Vendor/Contractor shall resume the work on the date so fixed. Vendor/Contractor shall be granted an adjustment in the contract price or an extension of the contract times, or both, directly attributable to any such suspension if Vendor/Contractor makes a claim therefore as provided in above Section titled: "CHANGES IN THE WORK; CLAIMS".
- E. Owner May Terminate for Cause:
1. The occurrence of any one (1) or more of the following events will justify termination for cause:
    - a. Vendor/Contractor's persistent failure to perform the work in accordance with the Contract Documents (including, but not limited to, failure to supply sufficient skilled workers or suitable materials or equipment or failure to adhere to the Progress Schedule established under above Section titled "STARTING THE WORK" Paragraph A. 2. a. as adjusted from time to time pursuant to above Section titled "CONTRACTOR'S RESPONSIBILITY" Paragraph titled "Progress Schedule";
    - b. Vendor/Contractor's disregard of laws or regulations of any public body having jurisdiction;
    - c. Vendor/Contractor's disregard of the authority of Engineer; or
    - d. Vendor/Contractor's violation in any substantial way of any provisions of the Contract Documents.
  2. If one (1) or more of the events identified in above Paragraph E. 1. occur, Owner may, after giving Vendor/Contractor (and surety) seven (7) days written notice of its intent to terminate the services of Vendor/Contractor:
    - a. In exercising the rights and remedies under above Section titled "TESTS AND INSPECTIONS; CORRECTION, REMOVAL/ACCEPTANCE OF DEFECTIVE WORK" Paragraph titled "Owner May Correct Defective Work", Owner shall proceed expeditiously. In connection with such corrective or remedial action, Owner may exclude Vendor/Contractor from all or part of the site (without liability to Vendor/Contractor for trespass or conversion), take possession of all or part of the work and suspend Vendor/Contractor's services related thereto, take possession of Vendor/Contractor's tools, appliances, construction equipment and machinery at the site, and incorporate in the work all materials and equipment stored at the site or for which Owner has paid Vendor/Contractor but which are stored elsewhere. Vendor/Contractor shall allow Owner, Owner's Designated representatives, agents and employees, Owner's other Vendor/Contractors, and Engineer and Engineer's consultants access to the site to

enable Owner to exercise the rights and remedies under above Section titled "TESTS AND INSPECTIONS; CORRECTION, REMOVAL/ACCEPTANCE OF DEFECTIVE WORK" Paragraph titled "Owner May Correct Defective Work".

- b. Complete the work as Owner may deem expedient.
3. If Owner proceeds as provided in Paragraph E. 2 above, Vendor/Contractor shall not be entitled to receive any further payment until the work is completed. If the unpaid balance of the contract price exceeds all claims, costs, losses, and damages (including but not limited to all fees and charges of engineers, architects, attorneys, and other professionals and all court or arbitration or other dispute resolution costs) sustained by Owner arising out of or relating to completing the work, such excess will be paid to Vendor/Contractor. If such claims, costs, losses, and damages exceed such unpaid balance, Vendor/Contractor shall pay the difference to Owner. Such claims, costs, losses, and damages incurred by Owner will be reviewed by Engineer as to their reasonableness and, when so approved by Engineer, incorporated in a change order. When exercising any rights or remedies under this paragraph Owner shall not be required to obtain the lowest price for the work performed.
4. Notwithstanding above Paragraphs E. 2. and E. 3., Vendor/Contractor's services will not be terminated if Vendor/Contractor begins within seven (7) days of receipt of notice of intent to terminate to correct its failure to perform and proceeds diligently to cure such failure within no more than thirty (30) days of receipt of said notice.
5. Where Vendor/Contractor's services have been so terminated by Owner, the termination will not affect any rights or remedies of Owner against Vendor/Contractor then existing or which may thereafter accrue. Any retention or payment of moneys due Vendor/Contractor by Owner will not release Vendor/Contractor from liability.
6. If and to the extent that Vendor/Contractor has provided a Performance Bond under the provisions of above section, titled: "PERFORMANCE AND PAYMENT BOND" , the termination procedures of that bond shall supersede the provisions of above Paragraphs E. 2. and E. 3.

F. Litigation:

1. Should the Owner be temporarily prohibited or enjoined from proceeding with the work herein contemplated, the Vendor/Contractor shall not be entitled to any claim or damages, or otherwise, nor may the Vendor/Contractor withdraw from the Contract except by and with the consent of the Owner. The Vendor/Contractor shall, however, be entitled to an extension of time for completion of the work equal to the time of such interruption or delay as determined and certified by the Owner Designated Representative.
2. If the Owner is permanently prohibited or enjoined from proceeding with the work herein contemplated, the Owner may terminate this Contract and pay the Vendor/Contractor a sum equal to all expenses legitimately incurred by him in connection with this work, plus ten

percent (10%) of such expenses, less an amount equal to the sum of all partial payments previously made to the Vendor/Contractor. The sum thus computed shall be paid to the Vendor/Contractor within thirty (30) days after the Owner shall have terminated this Contract and the payment of said sum shall be payment in full for any and all liquidated damages for the termination of this Contract and shall constitute full settlement of all claims in connection with this Contract.

#### 6.24. DISPUTE RESOLUTION

- A. Owner and Vendor/Contractor may mutually request mediation of any claim submitted to the Owner for a decision as provided in above Section titled "CHANGES IN THE WORK; CLAIMS:" Paragraph entitled "Claims" before such decision becomes final and binding. The mediation will be governed by the Construction Industry Mediation Rules of the American Arbitration Association in effect as of the effective date of the Agreement. The request for mediation shall be submitted in writing to the American Arbitration Association. Timely submission of the request shall stay the effect as described in said "Claims" Paragraph .
- B. Owner and Vendor/Contractor shall participate in the mediation process in good faith. The process shall be concluded within sixty (60) days of filing of the request. The date of termination of the mediation shall be determined by application of the mediation rules referenced above.
- C. If the claim is not resolved by mediation, Chief Procurement Officer's action or denial pursuant to above Section entitled "CHANGES IN THE WORK; CLAIMS" Paragraph titled "Execution of Change Orders" paragraph C. or Paragraph Titled "Notification of Surety" Paragraph D. shall become final and binding thirty (30) days after termination of the mediation unless, within that time period, Owner or Vendor/Contractor:
  - 1. Agrees with the other party to submit the claim to another dispute resolution process, or
  - 2. Gives written notice to the other party of their intent to submit the claim to a court of competent jurisdiction.

#### 6.25. MISCELLANEOUS

- A. Giving Notice:
  - 1. Whenever any provision of the Contract Documents requires the giving of written notice, it will be deemed to have been validly given if:
    - a. Delivered in person to the individual or to a member of the firm or to an officer of the corporation for whom it is intended, or
    - b. Delivered at or sent by registered or certified mail, postage prepaid, to the last business address known to the giver of the notice.
- B. Computation of Times: When any period of time is referred to in the Contract Documents by days, it will be computed to exclude the first and include the last day of such period. If the last

day of any such period falls on a Saturday or Sunday or on a day made a legal holiday by the law of the applicable jurisdiction, such day will be omitted from the computation.

- C. Cumulative Remedies: The duties and obligations imposed by these Contract Documents and the rights and remedies available hereunder to the parties hereto are in addition to, and are not to be construed in any way as a limitation of, any rights and remedies available to any or all of them which are otherwise imposed or available by laws or regulations, by special warranty or guarantee, or by other provisions of the Contract Documents. The provisions of this paragraph will be as effective as if repeated specifically in the Contract Documents in connection with each particular duty, obligation, right, and remedy to which they apply.
- D. Survival of Obligations: All representations, indemnifications, warranties, and guarantees made in, required by, or given in accordance with the Contract Documents, as well as all continuing obligations indicated in the Contract Documents, will survive final payment, completion, and acceptance of the work or termination or completion of the Contract or termination of the services of Vendor/Contractor.
- E. Headings: Article and paragraph headings are inserted for convenience only and do not constitute parts of these Contract Documents.
- F. Specification and Drawings Furnished by the Owner: All specifications, drawings and copies thereof furnished by the Owner shall remain its property. They shall not be used on another project and, with the exception of those sets which have been signed in connection with the execution of the Agreement, shall be returned to the Owner upon completion of the project.
- G. Laws and Ordinances: The Contract Documents shall be governed by the laws of the State of Florida and the ordinances of Hernando County.
- H. Vehicle Licensing: All prime Vendor/Contractors, including their subs, must obtain a temporary vehicle license for each and every out-of-state vehicle, personal or business (including trailers) that will be operating on-site. The cost shall be borne by the Vendor/Contractor. You must present evidence of title to the Tax Collector's Office to obtain the required temporary licenses.
- I. Handicapped Non-discrimination: The Vendor/Contractor will not discriminate against any employee or applicant for employment because he or she is handicapped in regards to any position for which the employee or applicant for employment is qualified.

## 6.26. OTHER WORK AT THE SITE

### OTHER WORK AT THE SITE:

- A. Related Work at Site:
  1. Owner may perform other work related to the project at the site with Owner's employees, or via other direct contracts therefore, or have other work performed by utility owners. If such other work is not noted in the Contract Documents, then:

- a. Written notice thereof will be given to Vendor/Contractor prior to starting any such other work; and
    - b. If Owner and Vendor/Contractor are unable to agree on entitlement to or on the amount or extent, if any, of any adjustment in the contract price or contract times that should be allowed as a result of such other work, a claim may be made therefore as provided in above Section titled: "CHANGES IN THE WORK; CLAIMS" Paragraph titled: "Claims".
  2. Vendor/Contractor shall afford other Vendor/Contractors who are a party to such a direct contract, each utility owner and Owner, if Owner is performing other work with Owner's employees, proper and safe access to the site, a reasonable opportunity for the introduction and storage of materials and equipment and the execution of such other work and shall properly coordinate the work with theirs. Vendor/Contractor shall do all cutting, fitting, and patching of the work that may be required to properly connect or otherwise make its several parts come together and properly integrate with such other work.  
Vendor/Contractor shall not endanger any work of others by cutting, excavating, or otherwise altering their work and will only cut or alter their work with the written consent of Owner Designated Representative and the others whose work will be affected. The duties and responsibilities of Vendor/Contractor under this paragraph are for the benefit of such utility owners and other Vendor/Contractors to the extent that there are comparable provisions for the benefit of Vendor/Contractor in said direct contracts between Owner and such utility owners and other Vendor/Contractors.
  3. If the proper execution or results of any part of Vendor/Contractor's work depends upon work performed by others under this section titled "OTHER WORK AT THE SITE", Vendor/Contractor shall inspect such other work and promptly report to Owner Designated Representative in writing any delays, defects, or deficiencies in such other work that render it unavailable or unsuitable for the proper execution and results of Vendor/Contractor's work. Vendor/Contractor's failure to so report will constitute an acceptance of such other work as fit and proper for integration with Vendor/Contractor's work except for latent defects and deficiencies in such other work.
- B. Coordination:
1. If Owner intends to contract with others for the performance of other work on the project at the site, the following will be set forth in the Contract Documents:
    - a. The individual or entity who will have authority and responsibility for coordination of the activities among the various Vendor/Contractors will be identified;
    - b. The specific matters to be covered by such authority and responsibility will be itemized;  
and

2. Unless otherwise provided in the Contract Documents, Owner shall have sole authority and responsibility for such coordination.

## 6.27. SAFETY DATA SHEETS

### SAFETY DATA SHEETS:

- A. In accordance with Florida Emergency Planning and Community Right-to-Know Act, Chapter 252, Part II, Florida Statutes, it is the seller's duty to advise Hernando County if a product is a listed toxic substance and to provide a material safety data sheet (MSDS) at the time of delivery. Vendor/Contractors must comply with this procedure along with the Federal Emergency Planning and Community Right-to-Know Act (42 U.S.C. Ch 116) and the Federal Hazard Communications Standards (29CFR sec.1910.1200) all other applicable laws.

## 6.28. TRENCH SAFETY ACT

Bidder shall be solely responsible for complying with the Florida Trench Safety Act as established under 553.60 through 553.64, Florida Statutes, and under the OSHA excavation safety standards as established under 29 CFR 1926.650 (Sub-Part P) as amended. All costs associated with complying with these requirements shall be included in the bid. The Trench Safety Act Compliance Form attached in Questionnaire, must be submitted with the bid.

## 6.29. SCRUTINIZED COMPANIES Pursuant to Florida Statute 287.135 And 215.473

Vendor/Contractor must certify that the company is not participating in a boycott of Israel. Vendor/Contractor must also certify that Vendor/Contractor is not on the Scrutinized Companies that Boycott Israel List, not on the Scrutinized Companies with Activities in Sudan List, and not on the Scrutinized Companies with Activities in the Iran Petroleum Energy Sector List, or has been engaged in business operations in Cuba or Syria. Subject to limited exceptions provided in State law, the County will not contract for the provision of goods or services with any scrutinized company referred to above. Vendor/Contractor must submit the certification form included as an attachment to this Solicitation. Submitting a false certification shall be deemed a material breach of contract. The County shall provide notice, in writing, to the Vendor/Contractor of the County's determination concerning the false certification. The Vendor/Contractor shall have five (5) days from receipt of notice to refute the false certification allegation. If such false certification is discovered during the active contract term, the Vendor/Contractor shall have ninety (90) days following receipt of the notice to respond in writing and demonstrate that the determination of false certification was made in error. If the Vendor/Contractor does not demonstrate that the County's determination of false certification was made in error, then the County shall have the right to terminate the contract and seek civil remedies pursuant to Section 287.135, Florida Statutes, as amended from time to time.

## 7. SCOPE AND SPECIFICATIONS

### 7.1. Scope of Work

Hernando County is soliciting licensed general contractors for the construction of Hernando Fire Station 15 located at 10270 Atlanta Ave., Brooksville, FL 34614. The project consists of the construction of a 9,608 square foot, 3-bay fire station and includes exterior and interior finishes, electrical systems, mechanical systems, fire protection, and plumbing. Limited site work includes new sidewalks, asphalt, concrete driveway, parking, drainage, and landscape improvements. The structure is composed of concrete slabs on grade, structural brick walls, stucco on concrete masonry unit walls, interior metal stud framing, and TPO roofing on steel joists over metal deck. Technical specifications, plans, and drawings are included as attachments.

Contractor is responsible for all labor, equipment, materials, all permits, and any incidentals required for project completion. Contractor shall carefully examine the bid documents, including the attached technical specifications, plans, and drawings, and conduct a project site visit to ascertain the conditions of work required for project completion. All work shall be completed in accordance with industry standards and federal, state, and local regulations.

### 7.2. Alternates

The cost or credit for each alternate is the net addition to or deduction from the Contract Sum to incorporate alternates into the Work as described in Attachment B - Construction Plan Portfolio FS15 - Permit Technical Specifications. No other adjustments shall be made to the Contract Sum.

#### A. Add Alternates:

Contractor is instructed not to provide pricing for Add Alternates 1-4 as described below. Alternates 1-4 will not be included in this solicitation.

- Alternate No. 1: Add alternate for full turnkey VVW disinfecting lighting fixtures. Locations are Dayroom 106, Kitchen 107, and Dining Room 108. Refer to Electrical Drawings for additional requirements.
- Alternate No. 2: Add alternate for RGB color-changing exterior light fixtures. Refer to Electrical Drawings for additional requirements.
- Alternate No. 3: Full turnkey access control system. Refer to Electrical Drawings and Technology Drawings for additional requirements.
- Alternate No. 4: Epoxy flooring in the Apparatus Bay.

#### B. Deductive Alternates

Contractor shall provide pricing for Deductive Alternates 5-8 listed below to be deducted from the Contract Sum.

- Alternate No. 5: Deduct for Exterior canopy. Includes gutter and downspouts.

- Alternate No. 6: Deduct for Plastic laminate casework in lieu of Plyboo in the kitchen.
- Alternate No. 7: Deduct to remove casework in dorms.
- Alternate No. 8: Deduct to remove all panic hardware.

## 8. PRICING PROPOSAL

The Vendor/Contractor shall provide all labor and other resources necessary to provide the supplies, equipment and/or services in strict accordance with the specifications defined in this Solicitation for the amounts specified in this Pricing Proposal, inclusive of overhead, profit and any other costs.

Vendor/Contractor is to understand that the total bid price is based on the estimated quantities indicated as follows and will control in awarding the Contract as provided in the Solicitation Instructions. It is further understood that the quantities stated in the Pricing Proposal for various items are estimated only and may be increased or decreased as provided in the Contract.

### PRICING PROPOSAL

Line Item	Description	Quantity	Unit of Measure	Unit Cost	Total
1	Lump Sum new fire station #15-for all scope shown on plans and in specifications prepared by Wannemacher Jensen Architects dated December 12, 2025, included with this solicitation, including any and all addenda.	1	LS		
<b>TOTAL</b>					

### ALTERNATES PRICING

The cost or credit for each alternate is the net addition to or deduction from the Contract Sum to incorporate alternates into the work as specified. No other adjustments shall be made to the contract sum.

Line Item	Description	Quantity	Unit of Measure	Unit Cost	No Bid	Total
<b>Deductive Alternates</b>						
5	Alternate #5 - Deduct for Exterior Canopy. Includes gutter and downspouts.	1	LS			
6	Alternate #6 - Deduct for plastic laminate casework in lieu of Plyboo in the kitchen.	1	LS			

Line Item	Description	Quantity	Unit of Measure	Unit Cost	No Bid	Total
7	Alternate #7 - Deduct to remove casework in dorms.	1	LS			
8	Alternate #8 - Deduct to remove all panic hardware.	1	LS			
<b>TOTAL</b>						

## 9. VENDOR QUESTIONNAIRE (CONSTRUCTION)

### 9.1. Company Information

#### 9.1.1. *Vendor Registration\**

Please download the below documents, complete, and upload.

- [Vendor-Registration-Form.pdf](#)

\*Response required

#### 9.1.2. *W9 Form \**

Please upload your company's W9 information

\*Response required

#### 9.1.3. *Upload Florida Permit*

**Bidders who are non-resident corporations** shall furnish to the Owner a duly certified copy of their permit to transact business in the State of Florida along with the bid. Failure to submit this evidence or qualification to do business in the State of Florida may be basis for rejection of the bid.

#### 9.1.4. *Local Preference.\**

If you are claiming local preference, please download the below documents, complete, and upload.

- [LOCAL VENDOR AFFIDAVIT OF E...](#)

\*Response required

### 9.2. Authorizations

#### 9.2.1. *Authorized Representative\**

Are you fully authorized to bind this company, or corporation.

- Yes  
 No

\*Response required

#### 9.2.2. *Authorized Signatory/Negotiator\**

Please provide the information to support the statement below:

The Firm/Contractor represents that the following persons are authorized to sign and/or negotiate contracts and related documents to which the Firm/Contractor will be duly bound:

Name(s)

Title(s)

Email(s)

Phone(s)

Business Address(s)

\*Response required

### 9.2.3. *Corporate Affidavit\**

Please download the below documents, complete, and upload.

- [Corporate Affidavit \(4\).pdf](#)

\*Response required

## 9.3. Confirmations

### 9.3.1. *Pricing Offered\**

THE UNDERSIGNED, BEING DULY AUTHORIZED TO SUBMIT THIS BID ON BEHALF OF THE BIDDER, AGREES THAT THIS OFFER IF ACCEPTED WITHIN ONE HUNDRED TWENTY (120) DAYS FROM THE BID OPENING DATE, TO FURNISH TO HERNANDO COUNTY ANY AND ALL ITEMS FOR WHICH PRICES ARE OFFERED IN THIS BID SOLICITATION AT THE PRICE(S) SO OFFERED, DELIVERED AT DESIGNATED POINT(S), WITHIN THE TIME PERIOD SPECIFIED, AND AT THE TERMS AND CONDITIONS SO STIPULATED IN THE SOLICITATION FOR BIDS.

Please confirm

\*Response required

### 9.3.2. *Acceptance of Terms and Conditions\**

By responding to this Solicitation, the bidder certifies that he/she has reviewed the sample contract, and its exhibits contained herein, and is familiar with their terms and conditions and finds them expressly workable without change or modification.

We certify and declare that the foregoing is true and correct.

**Please acknowledge below that you confirm the above statement:**

Please confirm

\*Response required

### 9.3.3. *Acknowledgement\**

Agree at the time of submitting its bid that no further examinations, investigations, explorations, tests, studies, or data are necessary for the determination of its bid for performance of the work at the price(s) bid and within the times and in accordance with the other terms and conditions of the bid documents.

Please confirm

\*Response required

### 9.3.4. *Submission Confirmation\**

The undersigned, hereinafter called "Bidder", having visited the site of the proposed project and familiarized himself with the local conditions, nature and extent of the work, and having examined carefully the agreement form, General Conditions, Special Conditions, Supplementary Conditions for Federal/State Requirements, plans and specifications and other contract documents, with the bond

requirements herein, proposed to furnish all labor, materials, equipment and other necessary items, facilities and services for the proper execution and completion of the subject project in full accordance with the drawings and specifications prepared in accordance with your Advertisement of Bids, instruction to bidders, agreement and all other documents related thereto on file in the office of the Hernando County Procurement Department and if awarded the Contract, to complete said work within the time limits specified for their bid price.

Please confirm

\*Response required

### **9.3.5. Drug Free Workplace Certification \***

I have read and attest to, in accordance with Florida Statute 287.087, hereby certify that bidder:

Publishes a written statement notifying that the unlawful manufacture, distribution, dispensing, possession or use of a controlled substance is prohibited in the workplace named above, and specifying actions that will be taken against violations of such prohibition.

Informs employees about the dangers of drug abuse in the workplace, the firm's policy of maintaining a drug free working environment, and available drug counseling, rehabilitation, and employee assistance programs, and the penalties that may be imposed upon employees for drug use violations.

Gives each employee engaged in providing commodities or contractual services that are under proposal a copy of the statement specified above.

Notifies the employees that as a condition of working on the commodities or contractual services that are under proposal, the employee will abide by the terms of the statement and will notify the employer of any conviction of, pleas of guilty or nolo contendere to, any violation of Chapter 893, or of any controlled substance law of the State of Florida or the United States, for a violation occurring in the workplace, no later than five (5) days after such conviction, and requires employees to sign copies of such written statement to acknowledge their receipt.

Imposes a sanction on, or requires the satisfactory participation in, a drug abuse assistance or rehabilitation program, if such is available in the employee's community, by any employee who is so convicted.

Makes a good faith effort to continue to maintain a drug free workplace through the implementation of the Drug Free Workplace Program.

"As a person authorized to sign this statement, I certify that the above named business, firm or corporation complies fully with the requirements set forth herein".

Please Confirm that you have read and attest to this Drug Free Workplace Certificate

Please confirm

\*Response required

### **9.3.6. VENDOR CERTIFICATION REGARDING SCRUTINIZED COMPANIES\***

Section 287.135, Florida Statutes, prohibits agencies from contracting with companies for goods or services of \$1,000,000.00 or more, that are on either the Scrutinized Companies with Activities in Sudan List, the Scrutinized Companies with Activities in the Iran Petroleum Energy Sector Lists which are created pursuant to s. 215.473 F.S., or the Scrutinized Companies that Boycott Israel List, created pursuant to s. 215.4725 F.S., or companies that are engaged in a boycott of Israel or companies engaged in business operations in Cuba or Syria.

As the person authorized to bind on behalf of respondent, I hereby certify that the company identified above in the section entitled "Respondent Vendor Name" is not listed on either the Scrutinized Companies with Activities in Sudan List or the Scrutinized Companies with Activities in the Iran Petroleum Energy Sector List, or the Scrutinized Companies that Boycott Israel List. I further certify that the company is not engaged in a boycott of Israel. I understand that pursuant to section 287.135, Florida Statutes, the submission of a false certification may subject company to civil penalties, attorney's fees, and/or costs and does not have business operations in Cuba or Syria.

I have read and attest that I confirm the above is acknowledged.

Please confirm

\*Response required

#### 9.3.7. *Award\**

Every Bidder must take notice of the fact that even though his proposal be accepted and the documents signed by the Bidder to whom an award is made and by those officials authorized to do so on behalf of Hernando County, Florida, that no such award or signing shall be considered a binding contract without a certificate from the Finance Director that funds are available to cover the cost of the work to be done, or without the approval of the County Attorney as to the form and legality of the Contract and all the pertinent documents relating thereto having been approved by said County Attorney; and such Bidder is hereby charged with this notice.

The signer of the proposal, as Bidder, also declares that the only person, persons, company or parties interested in this proposal, are named in the proposal, that he has carefully examined the Advertisement of Bid, Solicitation Instructions, Contract Specifications, Plans, Supplementary Conditions for Federal/State Requirements, General Conditions, Special Conditions, Special Provisions and contract bond, that he or his representative has made such investigation as is necessary to determine the character and extent of the work and he proposes and agrees that if the proposal be accepted, he will contract with Hernando County, Florida in the form of contract hereto annexed, to provide the necessary labor, materials, machinery, equipment, tools or apparatus, do all the work required to complete the Contract within the time mentioned in the Contract Documents according to the requirements of Hernando County, Florida, as herein and hereinafter set forth, and furnish the required surety bonds for the following prices to wit:

Please confirm

\*Response required

**9.3.8. E-Verify Certification \***

**Vendor/Contractor acknowledges and agrees to the following:**

Vendor/Contractor shall utilize the U.S. Department of Homeland Security's E-Verify system, in accordance with the terms governing use of the system, to confirm the employment eligibility of:

All persons employed by the Vendor/Contractor during the term of the Contract to perform employment duties within Florida; and

All persons, including subcontractors, assigned by the Vendor/Contractor to perform work pursuant to the Contract with the department.

Please confirm

\*Response required

**9.3.9. Affidavit of Non Collusion and of Non-Interest of Hernando County Employees\***

**Affidavit of Non Collusion and of Non-Interest of Hernando County Employees**

Certification that Vendor/Contractor affirms that the bid/proposal presented to the Owner is made freely, and without any secret agreement to commit a fraudulent, deceitful, unlawful or wrongful act of collusion.

I have read and attest that I am the Vendor/Contractor in the above bid/proposal, that the only person or persons interested in said proposal are named therein; that no officer, employee or agent of the Hernando County Board of County Commissioners (BOCC) or of any other Vendor/Contractor is interested in said bid/proposal; and that affiant makes the above bid/proposal with no past or present collusion with any other person, firm or corporation.

Please confirm that you have read and attest to Affidavit of Non Collusion and of Non-Interest of Hernando County Employees.

Please confirm

\*Response required

**9.3.10. Foreign Countries of Concern 287.138\***

287.138 F.S., prohibits agencies from contracting with companies which grant the Vendor/Contractor access to personal identifiable information if: a) the Contractor is owned by the government of a Foreign Country of Concern (as defined by the statute); (b) the government of a Foreign Country of Concern has a controlling interest in the entity; or (c) the Contractor is organized under the law of or has its principal place of business in a Foreign Country of Concern.

As the person authorized to bind on behalf of respondent, I hereby certify that the company identified above in the section entitled "Respondent Vendor Name" is not owned, controlled or organized under the law of a Foreign Country of Concern as identified in Section 287.138, Florida statutes. I understand that the submission of a false certification may subject company to civil penalties, attorney's fees, and/or costs.

I have read and attest that I confirm the above is acknowledged.

Please confirm

\*Response required

**9.3.11. Sworn Statement 287.133 (3) (a)\***

I have read and attest that I understand that a "public entity crime" as defined in Paragraph 287.133 (1)(g), Florida Statutes, means a violation of any public entity or with an agency or political subdivision of any other state or of the United States, including, but not limited to, any proposal or contract for goods or services to be provided to any public entity or an agency or political subdivision of any other state or of the United States and involving antitrust, fraud, theft, bribery, collusion, racketeering, conspiracy, or material misrepresentation.

I have read and attest that I understand that "convicted" or "conviction" as defined in Paragraph 287.133 (1)(b), Florida Statutes, means a finding of guilt or a conviction of a public entity crime, with or without an adjudication of guilt, in any Federal or State trial court of record relating to charges brought by indictment or information after July 1, 1989, as a result of a jury verdict, non-jury trial, or entry of a plea of guilty or nolo contendere.

I have read and attest that I understand that an "affiliate" as defined in Paragraph 287.133 (1)(a), Florida Statutes, means:

- A. A predecessor or successor of a person convicted of a public entity crime; or
- B. An entity under the control of any natural person who is active in the management of the entity and who has been convicted of a public entity crime. The term "affiliate" includes those officers, directors, executives, partners, shareholders, employees, members, and agents who are active in the management of an affiliate. The ownership by one (1) person of shares constituting a controlling interest in another person, or a pooling of equipment or income among persons when not for fair market value under an arm's length agreement, shall be a prima facie case that one (1) person controls another person. A person who knowingly enters into a joint venture with a person who has been convicted of a public entity crime in Florida during the preceding thirty-six (36) months shall be considered an affiliate.

I have read and attest that I understand that a "person" as defined in Paragraph 287.133(1)(e), Florida Statutes, means any natural person or entity organized under the laws of any state or of the United States with the legal power to enter into a binding contract and which proposals or applies to proposal on contracts for the provisions of goods or services let by a public entity, or which otherwise transacts or applies to transact business with a public entity. The term "person" includes those officers, directors, executives, partners, shareholders, employees, members, and agents who are active in management of an entity.

I have read and attest that based on information and belief, the statement which I have confirmed below is true in relation to the entity submitting this sworn statement:

I UNDERSTAND THAT THE SUBMISSION OF THIS FORM TO THE CONTRACTING OFFICER FOR THE PUBLIC ENTITY IDENTIFIED IN PARAGRAPH ONE (1) ABOVE IS FOR THAT PUBLIC ENTITY ONLY AND, THAT THIS

FORM IS VALID THROUGH DECEMBER 31, OF THE CALENDAR YEAR IN WHICH IT IS FILED. I ALSO UNDERSTAND THAT I AM REQUIRED TO INFORM THE PUBLIC ENTITY PRIOR TO ENTERING INTO A CONTRACT.

Neither the entity submitting this sworn statement, nor any of its officers, directors, executives, partners, shareholders, employees, members, or agents who are active in the management of the entity, nor any affiliate of the entity has been charged with and convicted of a public entity crime subsequent to July 1, 1989.

The entity submitting this sworn statement, or one (1) or more of its officers, directors, executives, partners, shareholders, employees, members, or agents who are active in the management of the entity, or an affiliate of the entity has been charged with and convicted of a public entity crime subsequent to July 1, 1989.

The entity submitting this sworn statement, or one (1) or more of its officers, directors, executives, partners, shareholders, employees, members, or agents who are active in the management of the entity, or an affiliate of the entity has been charged with and convicted of a public entity crime subsequent to July 1, 1989. However, there has been a subsequent proceeding before a Hearing Officer of the State of Florida, Division of Administrative Hearings and the Final Order entered by the Hearing Officer determined that it was not in the public interest to place the entity submitting this sworn statement on the convicted Vendor/Contractor list

\*Response required

*9.3.12. If you chose option 3, to the question above, 3.10 Sworn Statement 287.133(3) a, attach a copy of the final order.*

#### 9.4. Bid Bond

##### *9.4.1. Bid Bond Confirmation \**

If the foregoing proposal shall be accepted by Hernando County, Florida, and the undersigned shall fail to execute a satisfactory contract as stated in the advertisement herein attached, then the County may, at its option, determine that the undersigned has abandoned the Contract, and thereupon this proposal shall be null and void, and the certified check or bond accompanying this proposal, shall be forfeited to and become the property of Hernando County, Florida, and the full amount of said check shall be retained by the County, or if the proposal bond be given, the full amount of such bond shall be paid to the County as stipulated for liquidated damages; otherwise, the bond or certified check accompanying this proposal, or the amount of said check, shall be returned to the undersigned as specified herein.

If corporation, give the names and addresses of the president and secretary. If firm or partnership, the names and addresses of the members or partners. The Bidder shall list not only his name, but also the name of any person with whom Bidder has any type of agreement whereby such person's improvements, enrichment, employment of possible benefit, whether subcontractor, materialman, agent, supplier, or employer, is contingent upon the award of the Contract to the Bidder).

Please confirm

\*Response required

#### 9.4.2. *BID GUARANTEE\**

Bidder has enclosed a Certified check, Cashier's Check or Bid Bond in the amount of not less than the five percent (5%) of the Total Base Bid Amount payable to the Hernando County Board of County Commissioners as a guarantee for the purpose set out in the Instructions to Bidders.

Please confirm

\*Response required

#### 9.4.3. *Bid Bond Form*

Please download the below documents, complete, and upload.

- [Bid Bond Form \(2\).pdf](#)

### 9.5. Proposal/Qualifications

#### 9.5.1. *References \**

Proposer must provide a minimum of **three (3)** references using the format options shown below. A combination of the format options may be used as long as three complete references are provided.

References must be individuals that can be readily contacted and have first-hand knowledge of the Proposer's performance on the specific project performed by the Proposer. Each reference project must meet the following criteria:

Project at Substantial Completion or completed within the last seven (7) years.

Similar in size, dollar value and scope as this project.

**Option 1: Please provide the below information for 3 required References:**

Business/Owner Name

Reference Contact Person

Reference Address

Reference Phone No.

Reference Email Address

Project Name

Project Location

Contract Project Manager

Site Superintendent

Contract Amount

Date Project Commenced

Date of Substantial Completion

Date of Final Completion

Description of Work Performed

**Option 2: Please download the attached Reference Form and upload completed references.**

Note: Experience shall be related to successfully completed projects within the last seven (7) years (i.e., the project must have been Substantially Complete within seven (7) years of the due date of this solicitation. Only projects that are complete or substantially complete as of the solicitation due date will be considered).

By submitting this information, I certify that the qualifications questionnaire information is true and correct to the best of my knowledge.

- [Reference Check for Solicit...](#)

\*Response required

#### *9.5.2. Licenses*

The Bidder must be a registered to do business in the State of Florida. **All Bidder's and/or subcontractors performing work requiring a specialty license must be licensed in the State of Florida.** This includes but is not limited to electrical and mechanical trades, as well as any other earthwork Contractor on the Bidder's team. Provide evidence of the required licenses as listed in this Solicitation for Bidder and all subcontractors identified herein.

Classification

Issuing Government License

Issue Date:

License Number:

#### *9.5.3. Please provide construction experience\**

Overview of bidder/subcontractor construction experience, including a list of projects successfully completed and indicating Owner, location, Contract value and completion date.

\*Response required

#### *9.5.4. Experience Similar Size and Scope\**

Documentation of bidder/subcontractor two (2) projects, similar in scope and complexity to this project, which have been successfully completed by the Bidder within the past seven (7) years.

\*Response required

#### *9.5.5. ORGANIZATION CHART:\**

Bidder must provide an organization chart showing Bidder's team identifying specific responsibilities of Bidder and subcontractors.

\*Response required

#### *9.5.6. Key Subcontractors\**

Each Bidder must submit with its response a list of subcontractors who will perform the work in each of the following categories (key subcontractors). List the name of the proposed subcontractor, or "Bidder" if the Bidder will perform the work, after each work category:

Example:

- (1) Earthwork construction
- (2) Earthen dike construction
- (3) Soil bentonite backfill cut-off wall installation
- (4) Wet excavation/dredging work
- (5) Concrete form work
- (6) Equipment installation
- (7) Electrical and instrumentation installation
- (8) Control system integration
- (9) Wetland planting and establishment

**If no subcontractors will be employed please state "NONE"**

\*Response required

**9.5.7. PROJECT MANAGER AND SUPERINTENDENT QUALIFICATIONS:\***

Bidder must provide resumes of Project Manager and Superintendent listing qualifications, experience, education and training. The Project Manager and Superintendent must have adequate experience, generally considered as a working Project Manager/Superintendent on a minimum of two (2) projects, similar in size and scope to the Construction of Fire Station 15, within the past seven (7) years.

\*Response required

**9.6. Additional Required Forms**

**9.6.1. Trench Safety Act Compliance\***

Please download the below documents, complete, and upload.

- [Trench Safety Act Complian...](#)

\*Response required

**9.6.2. Hernando County Employment Disclosure\***

Please download the below documents, complete, and upload.

- [HC Employment Disclosure Ce...](#)

\*Response required

**9.6.3. *Anti Human Trafficking Affidavit\****

Please download the below documents, complete, and upload.

- [Anti\\_Human-Trafficking-Affi...](#)

\*Response required



## **ADDENDUM # ONE (1)**

TO  
THE CONTRACT DOCUMENTS  
FOR THE

**Construction of Fire Station 15**

IN  
HERNANDO COUNTY, FLORIDA

**SOLICITATION NO. 26-C01265/GB**

Bidders are required to acknowledge receipt of this Addendum via OpenGov prior to the time of the Bid Opening.

The following changes, additions are hereby made a part of the Contract Documents for the above-referenced Solicitation as fully and completely as if the same were fully set forth therein:

### **I. Questions and Answers**

**1.Q. Can you please provide structural drawings?**

1.A. Refer to Attachment B - Construction of FS 15 Portfolio.

**2.Q. Where can I find the electrical drawings with specifications and legend for low voltage work you would like bid?**

2.A. Refer to Attachment B - Construction of FS 15 Portfolio, Electrical and technology drawings and project spec book

**3.Q. I wanted to get the bid plans for this project. I downloaded what is available through the portal, but I only see structural plans. How can I get the complete set of plans?**

3.A. Refer to Attachment B - Construction of FS 15 Portfolio. Balance and complete plans are within the portfolio.

**4.Q. Will there be any requirements OR interest in Drone Services on this project? i.e. pre/post site conditions, progress photos, video, 360 Aerial panos, 2d site overview etc.?**

4.A. No.

**5.Q. What is the manufacturer of the existing card access control system?**

5.A. Avigilon is the County standard; however, access controls will not be installed for this project.

**6.Q. Do you have an estimated start date and duration for this project?**

6.A. Refer to Section 6.2 – Starting the Work, Section B.

**7.Q. Is there a detail for the firetruck filling stations?**



## PROCUREMENT DEPARTMENT

15470 FLIGHT PATH DRIVE ♦ BROOKSVILLE, FLORIDA 34604  
P 352.754.4020 ♦ F 352.754.4199 ♦ W www.HernandoCounty.us

- 7.A. Refer to Attachment B - Construction of FS 15 Portfolio. Balance and complete plans are within the portfolio.
- 8.Q. Is the pre-bid meeting mandatory in person? Or is it acceptable to join the Zoom meeting to satisfy the attendance requirement?**
- 8.A. Refer to Section 2.2 Mandatory Pre-Bid. There is no zoom meeting associated with the Mandatory Pre-Bid Meeting.
- 9.Q. Please update Pricing Proposal to include Alternates #1-4. Currently, only Alternate #5-8 are provided.**
- 9.A. Refer to Section 7. Scope of Work, 7.2. Alternates, subsection A.

### **II. CHANGES**

1. Section 6.2. Starting the Work, Section A. subsection 2.  
Within ~~ten (10)~~ fourteen (14) calendar days after the effective date of the Agreement (unless otherwise specified),
2. Section 6.2. Starting the Work, Section 6.2., Section B.  
The Vendor/Contractor will start the work within ~~ten (10)~~ fourteen (14) calendar days of the official Notice to Proceed date. The Contract Time shall commence to run from the date of the Notice to Proceed.

### **III. ATTACHMENTS**

Attachment B – Construction Plan Portfolio FS15 pdf file is replaced in its entirety with Attachment B – B Construction Plan Portfolio FS15 zip folder.

### **BOARD OF COUNTY COMMISSIONERS OF HERNANDO COUNTY, FLORIDA**

Felicia Holmes, CPPO, CPPB, NIGP-CPP

For: Carla Rossiter-Smith MSM, PMP, GPC  
Chief Procurement Officer



## PROCUREMENT DEPARTMENT

15470 FLIGHT PATH DRIVE ♦ BROOKSVILLE, FLORIDA 34604  
P 352.754.4020 ♦ F 352.754.4199 ♦ W www.HernandoCounty.us

# ADDENDUM # TWO (2)

TO  
THE CONTRACT DOCUMENTS  
FOR THE  
**Construction of Fire Station 15**  
IN  
HERNANDO COUNTY, FLORIDA  
**SOLICITATION NO. 26-C01265/GB**

Bidders are required to acknowledge receipt of this Addendum via OpenGov prior to the time of the Bid Opening.

The following changes, additions are hereby made a part of the Contract Documents for the above-referenced Solicitation as fully and completely as if the same were fully set forth therein:

### **I. Clarifications**

Correct Scrivener error to Addendum No. 1, 1.A.

#### **1.Q. Can you please provide structural drawings?**

1.A. Refer to Attachment E – 1003-037 Hernando County FS 15

Correct Scrivener errors:

Section 6.2. Starting the Work, Section A. subsection 2.

Within ~~fourteen (14)~~ ten (10) calendar days after the effective date of the Agreement (unless otherwise specified), Vendor/Contractor shall submit to the Engineer for review:

Section 6.2. Starting the Work, Section 6.2., Section B.

The Vendor/Contractor will start the work within ten (10) ~~fourteen (14) calendar~~ days of the official Notice to Proceed date. The Contract Time shall commence to run from the date of the Notice to Proceed.

Section 6.2. Starting the Work, Section 6.2., Section A.2.C.

Within fourteen (14) calendar days of the Notice of Intent to Award, a preliminary Schedule of Values for all the work which will include quantities and prices of items aggregating the contract price and will subdivide the work into component parts in sufficient detail to serve as the basis for progress payments during construction. Such prices will include an appropriate amount of overhead and profit applicable to each item of work.

### **BOARD OF COUNTY COMMISSIONERS OF HERNANDO COUNTY, FLORIDA**

Felicia Holmes, CPPO, CPPB, NIGP-CPP

For: Carla Rossiter-Smith MSM, PMP, GPC  
Chief Procurement Officer



## ADDENDUM # THREE (3)

TO  
THE CONTRACT DOCUMENTS  
FOR THE

**Construction of Fire Station 15**

IN  
HERNANDO COUNTY, FLORIDA

**SOLICITATION NO. 26-C01265/GB**

Bidders are required to acknowledge receipt of this Addendum via OpenGov prior to the time of the Bid Opening.

The following changes, additions are hereby made a part of the Contract Documents for the above-referenced Solicitation as fully and completely as if the same were fully set forth therein:

### **I. Questions and Answers**

**10.Q. Can a state registered low voltage licensed technician be used in lieu of a BICSI certified company for the technology package?**

10.A. A state-registered low-voltage licensed technician is acceptable in lieu of a BICSI-certified company, provided that the technician holds a valid State of Florida license for this scope of work. Cable certification test results and all required testing/warranty documentation must be submitted at project turnover, as required by the specifications.

**11.Q. What is the estimated project value?**

11.A. \$7 Million

**12.Q. When reviewing documents I show "B-Construction Portfolio FS15" references when opened Fire Station #16. Can you please provide specifications for Fire Station #15?**

12.A. Any and all references in the solicitation documents to Fire Station 16, shall be deemed relevant and the same as Fire Station 15.

**13.Q. Has a Gopher Tortoise survey been performed for this project? If yes, please provide the report, GIS data, and any associated findings.**

13.A. The County will be responsible for gopher tortoise survey and remediation. Contractor shall provide construction fencing around the site to prevent any intrusion of tortoises onto the site during construction. The fencing shall be placed on the west and northern edges of the natural vegetation area which will allow for any existing tortoises to remain or others located within the areas of construction to be relocated on site.



## PROCUREMENT DEPARTMENT

15470 FLIGHT PATH DRIVE ♦ BROOKSVILLE, FLORIDA 34604  
P 352.754.4020 ♦ F 352.754.4199 ♦ W [www.HernandoCounty.us](http://www.HernandoCounty.us)

- 14.Q. If a survey has not been conducted, please confirm whether the Owner intends to procure an ecological consultant to perform the required survey or have the contractor include this service in pricing.**
- 14.A. Refer to 13.A.
- 15.Q. If tortoises are identified, please confirm who is responsible for coordinating the FWC-approved relocation plan and securing necessary permits and provide any available information on the intended recipient relocation site, if established.**
- 15.A. Refer to 13.A.
- 16.Q. Please confirm whether any schedule allowances should be included for survey, permitting, or relocation activities.**
- 16.A. Refer to 13.A.
- 17.Q. Please confirm whether specifications for the following scopes are available or forthcoming: Earthwork, Fencing & Gates, Landscaping & Irrigation, Signalization/Traffic Sign, Fire Protection, Waterproofing, Sealants & Damp proofing, Flagpole, Window Coverings.**
- 17.A. Waterproofing and damp proofing N/A; above grade work only. Sealants were issued as Section 079200 - Joint Sealants. Flagpole noted on S301 Drawings; new spec section to be issued if required. Assume specified roller window shades (Section 122413) are the window coverings in question. Remainder of items are the responsibility of other disciplines. Refer to the Civil and Landscape drawings for the remaining information.
- 18.Q. Does this project require Davis Bacon Wage Rate? If yes, please provide the wage rate sheet for review.**
- 18.A. No. This is not a federally funded project.
- 19.Q. Does this project require following the BABA Act?**
- 19.A. No. This is not a federally funded project.
- 20.Q. Section 5.10 Licenses and Permits States: Permitting fees are to be included in our bid proposal by GC. Can you please provide a budget amount to be carried by all bidders for the permitting fees, so this is equal across the board.**
- 20.A. It is recommended \$10,000 as a baseline. Contractor to submit invoice against the allowance.
- 21.Q. On page E-002 lighting schedule. There are 2 "T" fixtures. Please provide the location of a 4' ft. fixture for an alternate. Please provide the location of the called-out landscape fixture.**
- 21.A. The "T" fixture referenced on Sheet E-002 is not included in the project scope. Please disregard the "T" fixture.
- 22.Q. Please provide clarity on Note 28 Manhole on E-010.**
- 22.A. Note 28 - Sheet E010 is a reference for the Electrical Contractor to identify the proposed location of the traffic signal light per new civil document - Sheet C6 and to provide the electrical materials, devices and equipment required to facilitate the complete installation of traffic signal power/control as designed.
- 23.Q. Regarding Addendum 1, Question 5, can you please confirm that both the access control and video surveillance systems will be owner-provided, and the only items**



## PROCUREMENT DEPARTMENT

15470 FLIGHT PATH DRIVE ♦ BROOKSVILLE, FLORIDA 34604  
P 352.754.4020 ♦ F 352.754.4199 ♦ W www.HernandoCounty.us

**required during construction are the raceways/pathways by the electrical contractor for the future devices?**

23.A. Yes. They will be owner provided.

**24.Q. The electrical plans appear to be missing detail sheets E-505 through E-509 shown on the index on page G102.**

24.A. Latest electrical package includes sheet E-505. Electrical detail sheets E-506 through E509 previously were Greenheck Kitchen Hood reference documents which shall be shown on Mechanical Documents.

**25.Q. Please confirm whether the alternatives listed in the lighting schedule for Type EM are simply different model options for the same fixture type (E-002).**

25.A. Alternatives listed for Type EM represents a list of options for Type EM for selection by Architect/Owner Representative.

**26.Q. Light Type T (building and site) is not reflected in the plans, including the reflected ceiling plans (E-002). Please advise.**

26.A. The "T" fixture referenced on Sheet E-002 is not included in the project scope. Please disregard the "T" fixture.

**27.Q. Light Type F calls for an alternative alert light; however, it is not shown on the plans. We are unable to determine quantities or locations (E-002).**

27.A. Light Type Fs shall be confirmed with Mach Alert Vendor, Owner Low Voltage Representative if new alert system package shall include alert lights in Dorms or if Type 'F' shall be installed in it's place. Type 'F' shall include 0-10V dimming. Exclude type 'F' where Alert System package includes alert lighting in dorms. -KB, CMTA

**28.Q. Lighting Note 27 on sheet E-101 indicates to provide switches for the VYV alternative, but there are no VYV fixtures shown in those rooms. Please confirm.**

28.A. Lighting Note 27 pertains to a previously issued Add Alternate. Hernando County has elected to remove this Add Alternate from the project; therefore, the VYV fixtures and associated switching are no longer part of the scope of work.

All references to Add Alternate No. 1 will be removed as part of the first cycle of permit comment responses.

**29.Q. On sheet G-101 under "Add Alternates," it mentions changing the exterior light colors. However, this is not referenced in the electrical plans. Could you please clarify what is meant by this change?**

29.A. The reference to color-changing exterior lighting pertains to a previously issued Add Alternate. Hernando County has elected to remove this Add Alternate from the project; therefore, RGB color-changing exterior light fixtures are no longer part of the scope of work.

All references to Add Alternate No. 2 will be removed as part of the first cycle of permit comment responses.

**30.Q. Is Plexi-CHemie's Plexicrete SLBQ Self-Leveling Broadcast Flooring System @ 3/16th to 1/4 inch thickness and an acceptable equivalent for Sikafloor 24 NA PurCem?**

30.A. It is the Contractor's responsibility to verify product compatibility, performance criteria,



and compliance with the specified system requirements.

**31.Q. Is Belden Cat6 an acceptable substitute for Systimax Cat6?**

31.A. It is the Contractor’s responsibility to verify product compatibility, performance criteria, and compliance with the specified system requirements.

**32.Q. The site has a lot of garbage and debris. Do you want all of the garbage and debris removed? Also, are we to clean the areas that are not disturbed by construction?**

32.A. Yes. The Contractor shall remove all garbage and debris in and around the site.

**33.Q. Is it possible to reduce the self-perform level to 15%? 50% is almost impossible to hit in a building work of this size.**

33.A. Yes. The self-perform level is reduced to 15%.

**II. Changes**

The Pricing Proposal has been revised to reflect the following changes:

Section 7. Scope of Work and Specifications

1. Contractor to carry an owner contingency line item within their bid in the amount of \$250,000. The contingency shall only be used for items that arise during construction and requires approval by the owner for use.
2. Contractor shall provide a unit price for grouting subsurface anomalies. The base bid shall include grouting for 90 cubic yards spread over ten (10) holes with an average depth of 45 feet. The unit price shall be used in additive or deductive pricing dependent on actual conditions encountered on the site.

Section 8. Pricing Proposal

3. Unit pricing as follows:
 

Cost to drill 45’ in depth	Add per foot greater than 45’
	Deduct per foot less than 45’
4. Grout 90 cubic yards in base bid
 

Add per additional cubic yard
Deduct per cubic yard

**BOARD OF COUNTY COMMISSIONERS  
OF HERNANDO COUNTY, FLORIDA**

Felicia Holmes, CPPO, CPPB, NIGP-CPP

For: Carla Rossiter-Smith MSM, PMP, GPC  
Chief Procurement Officer



## **ADDENDUM # FOUR (4)**

TO  
THE CONTRACT DOCUMENTS  
FOR THE

**Construction of Fire Station 15**

IN  
HERNANDO COUNTY, FLORIDA

**SOLICITATION NO. 26-C01265/GB**

Bidders are required to acknowledge receipt of this Addendum via OpenGov prior to the time of the Bid Opening.

The following changes, additions are hereby made a part of the Contract Documents for the above-referenced Solicitation as fully and completely as if the same were fully set forth therein:

### **I. Questions and Answers**

**34.Q. The Florida Building Commission's ADVISORY letter dated October 30, 2024 requires that insulation R-Values be measured in accordance with FTC R-value Rule 460 (16 CFR 460) using current test methods, as defined by Section 460.5 of the Rule and as specified by Section C303.1.4 of the Florida Energy Conservation Code; further, manufacturers of insulation products are required to provide third-party certification of compliance with Rule 460 for both commercial and residential buildings. This requirement was made legally binding via the Building Commission's Declaratory Statement DS 2025-052, filed 1/13/2026. It's noteworthy that Section 5.11 of this project's Invitation to Bid, Section A., requires that "all..state laws,...rules and regulations of authorities having jurisdiction over any part of the project shall apply to the Contract." The Basis of Design brand specified in Section 072100.2.4.A.1, Tailored Chemical Products' Core-Fill 500, does not meet the Florida Building Commission's requirement. The advertised R-value of 4.9 per inch is for a 32 degree test temperature, not the 75 degree value required by Rule 460 (a clear violation of Rule 460), plus the ASTM C-177 test that supports this data is based on a single test of a 1-inch sample performed in 1980, 45 years ago, instead of the FTC Rule 460-required current versions of ASTM standards, either the 2013 version of ASTM C-177 or the 2017 version of ASTM C-518 which require tests to current standards of multiple sample thicknesses. Further, the Core-Fill 500 brand does not offer third party certification that the R-value tests are current and FTC 16 CFR 460-**



## PROCUREMENT DEPARTMENT

15470 FLIGHT PATH DRIVE ♦ BROOKSVILLE, FLORIDA 34604  
P 352.754.4020 ♦ F 352.754.4199 ♦ W [www.HernandoCounty.us](http://www.HernandoCounty.us)

compliant, as required by the Florida Building Commission's ADVISORY letter and Declaratory Statement. Given these facts, an alternate brand is available, Core Foam Masonry Foam Insulation by CfiFOAM, Inc., that is fully compliant with Florida's requirements, evidenced by ICC-ESL Report ESL-1648 issued April 2025, which is available as an attachment to the Declaratory Statement and is also available on the BOAF listing page. CfiFOAM's product has been widely used throughout the state of Florida for more than 20 years, via a wide number of authorized installers, including some the largest insulation conglomerates in the USA. Product information is available at [www.cfifoam.com](http://www.cfifoam.com). So, is the Core Foam Masonry Foam Insulation product by CfiFOAM, Inc. an acceptable substitute for the listed brand, Core-Fill 500 by Tailored Chemical Products? And, will the Core-Fill 500 brand be disallowed on this project unless it demonstrates full compliance with Declaratory Statement DS-2025-052 using R-value testing to current ASTM standards, verified by a current, nationally accredited certification agency report like ICC Evaluation Services?

- 34.A. This is an acceptable substitution. See the product specification section, Exhibit 1, attached.

### II. Date Changes

- 1. QUESTION SUBMISSION DEADLINE HAS BEEN CHANGED FROM 03/02/2026 AT 5:00 PM TO 04/06/26 AT 5:00 PM.**
- 2. BID SUBMISSION DEADLINE HAS BEEN CHANGED FROM 03/09/2026 AT 10:00 AM TO APRIL 20, 2026, AT 10:00 AM**

### III. Deletions

The following are removed from the project.

1. Requirements for propane tank and associated LP gas piping are hereby deleted from the Construction Plan Portfolio and the project.
2. Requirements for air compressor and associated piping are hereby deleted from the Construction Plan Portfolio and the project.

### IV. Exhibit



## PROCUREMENT DEPARTMENT

15470 FLIGHT PATH DRIVE ♦ BROOKSVILLE, FLORIDA 34604  
P 352.754.4020 ♦ F 352.754.4199 ♦ W [www.HernandoCounty.us](http://www.HernandoCounty.us)

Exhibit 1 – Section 07 21 19.13 Foamed-in-Place Aminoplast Masonry Foam Insulation

### **BOARD OF COUNTY COMMISSIONERS OF HERNANDO COUNTY, FLORIDA**

Felicia Holmes, CPPO, CPPB, NIGP-CPP  
For: Carla Rossiter-Smith MSM, PMP, GPC  
Chief Procurement Officer





**SECTION 07 21 19.13**  
**FOAMED-IN-PLACE AMINOPLAST MASONRY FOAM INSULATION**

[**Note:** Elements of this Guide Specification may be adapted to SECTION 04 20 00]

**Part 1 General**

- 1.1 Section includes
  - A. Foam-in-place insulation in core-cells of Concrete Masonry Unit (CMU) walls, wythe cavities of exterior walls and exterior stud-framed walls.
  - B. Foam-in-place sound control insulation for interior and exterior walls.
- 1.2 Related Sections: Section 04 20 00 – Unit Masonry
- 1.3 Referenced Standards
  - A. ASTM E-84 “Standard Test Method for Surface Burning Characteristics of Building Materials.”
  - B. ASTM C-518 “Standard Test Method for Steady-State Thermal Transmission Properties by Means of the Heat Flow Meter Apparatus.”
  - C. NFPA 259 “Standard Test Method for Potential Heat of Building Materials”
- 1.4 Submittals
  - A. Submit under provisions of Section 01 30 00.
  - B. Product Data: Manufacturer’s data on product, including:
    - 1. “Product Information” Sheet from Manufacturer.
    - 2. Safety Data Sheet (SDS) for CfiFOAM Aminoplast Masonry Foam Insulation.
    - 3. Upon request by the Architect, Installer shall provide test data showing compliance of the product with referenced standards.
- 1.5 Quality Assurance
  - A. Installer Qualifications: A firm with experience installing insulation systems of the type specified and authorized by the foam manufacturer.
- 1.6 Delivery, Storage and Handling
  - A. Delivery
    - 1. Materials shall be delivered to installer in manufacturer’s original, unopened, undamaged containers with identification labels intact.
    - 2. Installer will blend resin and foaming catalyst according to the manufacturer’s instructions prior to arriving at the jobsite and/or at the jobsite, at the installer’s discretion.
  - B. Storage and Handling
    - 1. Materials should be stored in original paper packages and boxes protected from moisture until used by installer.
    - 2. Once blended with water by installer, materials must be maintained at a minimum temperature of 75°F.

### 1.7 Project/Site Conditions

- A. The wall assembly must be essentially dry with no standing water in the CMU core cells and no visible wetness on exterior surfaces.
- B. Mortar must be adequately cured prior to installation of foam insulation.

## Part 2 Products

### 2.1 Manufacturers

- A. Basis of Design: cfiFOAM, Inc., PO Box 10393, Knoxville, TN 37939.  
Telephone: 800-656-3626. Fax: 865-588-6607. Website: [www.cfifoam.com](http://www.cfifoam.com).
- B. Occupied and/or soon to be occupied structures and framed structures shall be insulated with InsulSmart Interior Foam Insulation®.
- C. Structures in California, Connecticut, New Jersey and New Hampshire shall be insulated with InsulSmart MH®.
- D. Framed structures shall not be insulated with Core Foam Masonry Foam Insulation®.

### 2.2 Materials

#### A. CfiFOAM Aminoplast Masonry Foam Insulation (Foamed-in-Place)

- 1. Description: Cellular plastic insulation comprised of a spray-dried polymeric resin and a foaming catalyst concentrate that are combined with water for injection, along with compressed air, into the wall cavity by an authorized installer.
- 2. Surface Burning Characteristics – ASTM E84: Class A or Class I
  - a. Flame Spread: 25 or Less
  - b. Smoke Generated: Less than 450
  - c. Thickness: 3.5 inches (maximum thickness per test apparatus).
  - d. Tests performed by an independent, accredited laboratory located within the US.
- 3. Thermal Performance (foam) – ASTM C177 or ASTM C518:
  - a. k-Value: k-0.23/inch @ 75°F mean temperature.
  - b. R-Value: R-4.6/inch @ 75°F mean temperature.
- 4. Potential Heat – NFPA 259/ASTM D5865: Potential Heat ≤ 80 Btu/lb.
- 5. Dimensional Stability (Shrinkage)
  - a. ≤ 0.5% - 12x8x16 CMU Enclosed Core Cell
- 6. Density of Foam:
  - a. Wet Foam 12" x 12" x 12" box weight: 2-½ to 3-¼ lbs.
  - b. Cured Foam: 0.5-1.0 lbs./ft<sup>3</sup>

### 2.3 Product Substitutions

- A. Substitutions: Equal approved by the Architect.

## Part 3 Execution

### 3.1 General

- A. Comply with the instructions and recommendations of the foam-in-place insulation manufacturer.

### 3.2 Examination

#### A. Site Verification

- 1. Verify that the wall assembly is essentially dry.
- 2. Verify that no water is standing in core cells within the wall assembly.
- 3. Verify that mortar is adequately cured.

### 3.3 Preparation

#### A. Select the best location(s) to inject foam:

1. Preferably through wall surfaces to be covered.
2.  $\frac{5}{8}$ "- $\frac{7}{8}$ " holes to be drilled in masonry joints or directly through CMU face walls.

### 3.4 Installation Guidelines

A. All empty core cells and voids within each insulated wall shall be filled with foam insulation as shown on the drawings.

B. Walls can be filled using either top-fill or by pressure-injection techniques.

1. For top-fill, the installer must use an extension tube to begin installing foam from the bottom of the cavity, withdrawing the extension tube as foam fills the cavity.
2. For pressure-injection, holes are drilled in each CMU— $\frac{3}{8}$ " holes for visually sensitive areas for use with a low-volume touch-up gun,  $\frac{5}{8}$ " holes for use with a standard foam gun, or  $\frac{7}{8}$ " holes for use with a high-volume production gun—at an approximate height of four feet from finished floor level. Normally each vertical cell column is drilled and injected with foam in 10'-24' lifts.
3. CfiFOAM Aminoplast Masonry Foam Insulation is injected until it completely fills each vertical cell column, as evidenced by foam exiting adjacent injection holes. Repeat steps 1 and 2 at intervals of 10' to 14' above the initial row of injection holes, or as needed, until the wall is completely filled. Exit holes may be drilled beneath bond beams and at tops of walls to help visually verify complete foam filling.

C. After foam insulation sets, remove excess foam from outside of cavity, sweeping the wall and floor as needed. Cured foam is an inert material and, therefore, can be disposed of with other construction waste or worked into soils on-site in accordance with local regulations.

D. Patch holes with mortar to resemble adjacent surfaces.

### 3.5 Field Quality Control

#### A. Testing

1. Verify insulation density by random sampling of foam
  - a. Fill a 12x12x12 box with foam
  - b. Foam weight should be 2  $\frac{1}{2}$  - 3  $\frac{1}{4}$  lb.

#### B. Inspection

1. Verify complete filling of voids by drilling block face upon request.
2. Upon request by the Architect, Installer shall provide IR scans of all insulated masonry walls prepared and interpreted by IR technicians who are "BlockWallScanIR" trained and certified.
3. Correct all portions of the installation not in compliance with the Architect's requirements at no added cost to the Owner.

### 3.6 Protection

A. Product should be protected from excess moisture during initial 24-hour curing period after installation. A 72-hour curing period is normally required prior to painting.

B. Foam should not be exposed to surfaces over 190°F for sustained periods of time.

**END OF SECTION 07 21 19.13**

Reviewed: April 14, 2020



## ADDENDUM # FIVE (5)

TO  
THE CONTRACT DOCUMENTS  
FOR THE

Construction of Fire Station 15

IN  
HERNANDO COUNTY, FLORIDA

**SOLICITATION NO. 26-C01265/GB**

Bidders are required to acknowledge receipt of this Addendum via OpenGov prior to the time of the Bid Opening.

The following changes, additions are hereby made a part of the Contract Documents for the above-referenced Solicitation as fully and completely as if the same were fully set forth therein:

### I. Questions and Answers

**35.Q. Please clarify. Specification Section 083613 calls for the sectional doors to be Reynor AV300. Drawing Sheet G-101, Florida Product Approval Chart calls for SP20. Florida Product Approval Documents for FL15212 does not list AV300. Please clarify the sectional door model.**

35.A. Proceed with the SP20 model as shown in the Florida Product Approval documentation. Product specification attached.

**36.Q. Sheet S202 does not specify the reinforcement for the 8" concrete slabs. Please clarify.**

36.A The 8" slab shall be reinforced with #4 at 12" o.c. each way, top and bottom.

**37.Q. Sheet M-101 HVAC Keynote 11 calls for a Diesel Exhaust and CO detection system in the Apparatus Bay. Please provide details and specifications for this system. Please clarify, sheet M-701 Exhaust Fan Control Schematics EF-1 and EF-2 references a source capture system and says that EF-1 and EF-2 are controlled by thermostats.**

37.A. The County has added the emergency ventilation system control diagram to M-701 and removed the references to a source capture system. Added the EF-1 and EF-2 control thermostat location to M-101 in the apparatus bay. Refer to Attachment 3 – M-101 Ground Floor Plan - HVAC

**38.Q. Controls Schematics on M-701 reference a BAS System. Is there a BAS System on this project? Also please verify if specification section 230923 Instrumentation and Controls for HVAC is correct for Hernando County. Specification lists several manufacturers. Are all of these acceptable?**



## PROCUREMENT DEPARTMENT

15470 FLIGHT PATH DRIVE ♦ BROOKSVILLE, FLORIDA 34604  
P 352.754.4020 ♦ F 352.754.4199 ♦ W www.HernandoCounty.us

- 38.A. The County has updated the DOAS control sequence of operation to remove reference to the BAS system and control via interlocks with the VRF system and the kitchen hoods. 230923 is not relevant to the project and can be disregarded and removed from specs. Refer to Attachment 4 – M-701 Controls-HVAC.
- 39.Q. Please clarify what type of glazing is to be used on the interior door lite kits. Also, please clarify what type of glazing is to be used on the exterior door lite kits.**
- 39.A. Interior – ¼” clear, tempered where required (safety glazing)  
Exterior – min. 6mm, typically insulated or tempered depending on SU door type.
- 40.Q. A-405, A-409, A-501 call out structural brick headers at the hollow metal doors. Please provide details and specifications. Please clarify which doors have structural brick headers.**
- 40.A. The structural brick has been removed from the scope. Please refer to the structural drawings for all header requirements at door openings.
- 41.Q. Specification Section 112300 lists a washing machine, GE Appliances; Model No. GFW859SSN/SPN. Sheet ID-103 shows a WS-1 Unimac UTGC6EDG44 in Rm. 103B Emergency Decon. Are we to furnish and install a Unimac UTGC6EDG44, or should this be GE Appliances; Model No. GFW859SSN/SPN. Please clarify.**
- 41.A. Please proceed with the GE Appliance washing machine, Model No. GFW859SSN/SPN, as specified in Section 112300.
- 42.Q. For the gas monitoring values Note 1 & 3 for the Alert system this would be tied into the FA with a monitoring module and control relay however please confirm the Alert system is separate system from FA.**
- 42.A. Alerting system is separate from the fire alarm system. Provide connections as required.
- 43.Q. In Section 6.8 Contractors Responsibilities sub section D.9 Concerning Subcontractors, Suppliers and Others. This section states “The Vendor/Contractor shall not award work valued at more than fifty percent (50%) of the contract price to subcontractor(s), without prior written approval of the Owner. Is it possible to remove the self-perform requirement?”**
- 43.A. Yes. Refer to Addendum 3, 33.A.
- 44.Q. Will soil stabilization be required to achieve LBR40 with native soils? If so, what depth of stabilized material will be required under the sidewalk and concrete driveways?**
- 44.A. The requirement for soil stabilization is to be determined in the field by a Geotech analysis. The County will be responsible for Geotech analysis. The depth is yet to be determined.
- 45.Q. With respect to the 4" and 8" concrete driveways, please provide the depths of subgrade material that will have to meet the LBR40 requirement?**
- 45.A. Under the 4” concrete sidewalk, the subgrade material thickness shall be 6”. Under the 8” concrete, the subgrade material thickness shall be 12”.
- 46.Q. Is it required that the selected contractor purchase / carry Builder's Risk Insurance? There is conflicting information in the bid docs on who will be purchasing the policy. Page #39 of the ITB states Builder's Risk is required while Page #43 Item N.**



## PROCUREMENT DEPARTMENT

15470 FLIGHT PATH DRIVE ♦ BROOKSVILLE, FLORIDA 34604  
P 352.754.4020 ♦ F 352.754.4199 ♦ W [www.HernandoCounty.us](http://www.HernandoCounty.us)

- States the County will purchase. Please advise who will be responsible and bear the cost for the policy.**
- 46.A. Yes. Contractor will be responsible for Builders Risk Insurance. Builders Risk Insurance is the total value of the project, less ODP. Refer to Section 5.29 - Owner Direct Purchase.
- 47.Q. Please clarify and provide additional details where the Bird deterrent Assembly is located on the project as stated in Spec Section 109050 / 2.3.**
- 47.A. There is no bird deterrent included in this project.
- 48.Q. Please clarify and provide additional details where the LED Display is located on the project as stated in Spec Section 109050 / 2.5.**
- 48.A. LED display is not required for this project.
- 49.Q. Per spec section 015000 - Temp. facilities and controls Section - General, Paragraph 1.3(B, C, & D), it states all Sewer, Water, & Electrical Services are the responsibility of the CM. Please provide an allowance to be carried by all bidders for this cost or remove the requirement into others so all are bidding with same budget as it relates to these temp services.**
- 49.A. This specification is removed. The County will provide these services.
- 50.Q. Per Specification Section 013200 – Construction Progress Documentation, Paragraph 1.3(B)(G), the progress schedule is required/requested to be cost & resource Loaded. Can these requirements be considered for removal, as cost / resource loaded schedules are typically reserved for FDOT ownership state projects?**
- 50.A. Yes. The cost schedules are removed.
- 51.Q. Please confirm if a preconstruction video / photos of the jobsite are required as stated Per Specification 013233 Paragraph 1.2, (A.1).**
- 51.A. Yes. Preconstruction videos are required as stated in the specifications.
- 52.Q. Spec Section 3.2 Temp. Utility Installation - Section I & J state a telephone service (Landline) and desktop computer shall be provided onsite for the architect / owner to use. Please confirm this is an old specification and these items are not required in the temporary offices.**
- 52.A. These items are not required.
- 53.Q. Per spec section 015000, Paragraph 3.4, Section G. states a site enclosure fence shall be installed around the perimeter. Please confirm this is required and to what extents since there is a large portion of the site there is no work being done. Plans do not show temp. fence locations for including.**
- 53.A. A permanent perimeter fence is not required for the entire site. The construction area only shall have temporary construction fencing installed at six-foot (6') height.
- 54.Q. Please provide specifications on the Underground Liquid Propane Tank.**
- 54.A. All propane/gas equipment and piping will be removed by future addenda and replaced with electric equipment and fixtures.
- 55.Q. Are bidding contractors required to provide testing ONLY for the DAS system? Or are bidding contractors also including a DAS system? It is unknown until the**



## PROCUREMENT DEPARTMENT

15470 FLIGHT PATH DRIVE ♦ BROOKSVILLE, FLORIDA 34604  
P 352.754.4020 ♦ F 352.754.4199 ♦ W www.HernandoCounty.us

**time of testing of the building whether a system will be required or not. Please confirm what is to be included in our pricing for this.**

- 55.A. Provide a typical allowance for a potential BDA/DAS System. Testing shall be required through the GC utilizing a licensed BDA/DAS designer. In the event the test fails, the BDA/DAS system shall be required to be furnished and installed through a qualified BDA/DAS designer/installer, through the GC. Information shown within the solicitation documents is for infrastructure and general intent of the required system only.
- 56.Q. Hubbell has discontinued the pop-up outlets specified on the plans. Are "Jiangce Table Pop Up Power Data Center Connection Box With Outlet Network HDMI For Conference Desk" an acceptable alternate?**
- 56.A. Engineer has no exceptions taken. Please note, HDMI is not required or supported in those locations and a model that does not have HDMI ports shall be provided. Architect to confirm product selection is acceptable in terms of appearance.
- 57.Q. If Builder's Risk Insurance is required to be purchased / carried by the awarded GC, is it required for the full amount of the project including Sitework, Signalization, conc. flatwork, landscaping, irrigation, etc. or just the cost associated with the building construction?**
- 57.A. Yes. Refer to 46.Q. - Builders Risk Insurance is the total value of the project, less ODP. Refer to Section 5.29 - Owner Direct Purchase

## II. Changes

- 35.Q. - Attachment 2. – Section 083610 - Steel Sectional Doors
- 37.Q. – Attachment 3 – M-101 Ground Floor Plan - HVAC
- 38.Q. – Attachment 4 – M-701 Controls - HVAC

## BOARD OF COUNTY COMMISSIONERS OF HERNANDO COUNTY, FLORIDA

Felicia Holmes, CPPO, CPPB, NIGP-CPP

For: Carla Rossiter-Smith MSM, PMP, GPC  
Chief Procurement Officer

## HERNANDO FIRE STATION #15

### ATTACHMENT 2 - SECTION 083610 - STEEL SECTIONAL DOORS

#### PART 1 - GENERAL

##### 1.1 RELATED DOCUMENTS

- A. Drawings and general provisions of the Contract, including General and Supplementary Conditions and Division 01 Specification Sections, apply to this Section.

##### 1.2 SUMMARY

- A. Section Includes:
  - 1. Sectional-door assemblies.
- B. Related Requirements:
  - 1. Section 055000 "Metal Fabrications" for miscellaneous steel supports.
  - 2. Section 083613 "Aluminum Sectional Doors" for full view sectional doors.

##### 1.3 ACTION SUBMITTALS

- A. Product Data: For each type and size of sectional door and accessory.
  - 1. Include construction details, material descriptions, dimensions of individual components, profile door sections, and finishes.
  - 2. For power-operated doors, include rated capacities, operating characteristics, electrical characteristics, and furnished accessories.
- B. Shop Drawings: For each installation and for components not dimensioned or detailed in manufacturer's product data.
  - 1. Include plans, elevations, sections, and mounting details.
  - 2. Include details of equipment assemblies. Indicate dimensions, required clearances, method of field assembly, components, and location and size of each field connection.
  - 3. Include points of attachment and their corresponding static and dynamic loads imposed on structure.
  - 4. Include diagrams for power, signal, and control wiring.
- C. Samples: For each exposed product and for each color and texture specified, in manufacturer's standard size.
- D. Samples for Verification: For each type of exposed finish and for each color and texture required on the following components, in manufacturer's standard sizes:
  - 1. Metal for door sections.

##### 1.4 INFORMATIONAL SUBMITTALS

- A. Qualification Data: For Installer.
- B. Sample Warranties: For manufacturer's warranty and finish warranty.

##### 1.5 CLOSEOUT SUBMITTALS

- A. Maintenance Data: For sectional doors to include in maintenance manuals.
- B. Manufacturer's warranty.

## HERNANDO FIRE STATION #15

- C. Finish warranty.

### 1.6 QUALITY ASSURANCE

- A. Installer Qualifications: An entity that employs installers and supervisors who are trained and approved by manufacturer for both installation and maintenance of units required for this Project.

### 1.7 WARRANTY

- A. Manufacturer's Warranty: Manufacturer agrees to repair or replace components of sectional doors that fail in materials or workmanship within specified warranty period.
  - 1. Failures include, but are not limited to, the following:
    - a. Structural failures including, but not limited to, excessive deflection.
    - b. Failure of components or operators before reaching required number of operation cycles.
    - c. Faulty operation of hardware.
    - d. Deterioration of metals, metal finishes, and other materials beyond normal weathering and use; rust through.
    - e. Delamination of exterior or interior facing materials.
  - 2. Warranty Period: Two years from date of Substantial Completion.
- B. Finish Warranty: Manufacturer agrees to repair or replace components that show evidence of deterioration of factory-applied finishes within specified warranty period.
  - 1. Warranty Period: 10 years from date of Substantial Completion.

## PART 2 - PRODUCTS

### 2.1 MANUFACTURERS, GENERAL

- A. Source Limitations: Obtain sectional doors from single source from single manufacturer.
  - 1. Obtain operators and controls from sectional door manufacturer.

### 2.2 PERFORMANCE REQUIREMENTS

- A. General Performance: Provide sectional doors that comply with performance requirements specified without failure from defective manufacture, fabrication, installation, or other defects in construction and without requiring temporary installation of reinforcing components.
- B. Structural Performance, Exterior Doors: Capable of withstanding the design wind loads.
  - 1. Design Wind Load: As indicated on Drawings.
  - 2. Testing: In accordance with ASTM E330/E330M.
  - 3. Deflection Limits: Design sectional doors to withstand design wind loads without evidencing permanent deformation or disengagement of door components.
    - a. Deflection of door sections in horizontal position (open) shall not exceed 1/120 of door width.
    - b. Deflection of horizontal track assembly shall not exceed 1/240 of door height.
- C. Windborne-Debris Impact Resistance: Provide sectional doors complying with the following requirements:
  - 1. Glazed Openings: Pass ASTM E1886 Large Missile Test and cyclic-pressure tests in accordance with ASTM E1996 for basic protection and Wind Zone applicable to basic design wind speed indicated on Drawings.

## HERNANDO FIRE STATION #15

### 2.3 SECTIONAL-DOOR ASSEMBLY

- A. Steel Sectional Door: Provide sectional door formed with hinged sections and fabricated so that finished door assembly is rigid and aligned with tight hairline joints; free of warp, twist, and deformation; and complies with requirements in DASMA 102.
  - 1. Basis of Design Product: Raynor Garage Doors; SteelForm SP20.
- B. Operation Cycles: Door components and operators capable of operating for not less than 100,000 operation cycles. One operation cycle is complete when door is opened from closed position to the open position and returned to closed position.
- C. Air Infiltration: Maximum rate of 0.4 cfm/sq. ft. when tested in accordance with ASTM E283/E283M or DASMA 105.
- D. R-Value: 7.7.
- E. Steel Door Sections: ASTM A653/A653M, zinc-coated (galvanized), cold-rolled, commercial steel sheet with G60 zinc coating.
  - 1. Door-Section Thickness: 2 inches.
  - 2. Section Faces:
    - a. Thermal-Break Construction: Provide sections with continuous thermal-break construction separating the exterior and interior faces of door.
    - b. Exterior Face: Fabricated from single sheets, not more than 24 inches high; with horizontal meeting edges rolled to continuous, interlocking, keyed, rabbeted, shiplap, or tongue-in-groove, weather- and pinch-resistant seals and reinforcing flange return.
      - 1) Steel Sheet Thickness: 0.022-inch nominal coated thickness.
      - 2) Surface: Manufacturer's standard, ribbed.
    - c. Interior Face: Enclose insulation completely within steel exterior facing and interior facing material, with no exposed insulation. Provide the following interior-facing material:
      - 1) Zinc-Coated (Galvanized) Steel Sheet: With minimum nominal coated thickness of 0.0396 inch (20 gage).
  - 3. End Stiles: Enclose open ends of sections with channel end stiles formed from galvanized-steel sheet not less than 0.040-inch nominal coated thickness and welded to door section.
  - 4. Section Reinforcing: Horizontal and diagonal reinforcement as required to stiffen door and for wind loading. Provide galvanized-steel bars, struts, trusses, or strip steel, formed to depth and bolted or welded in place. Ensure that reinforcement does not obstruct vision lites.
    - a. Bottom Section: Reinforce section with a continuous channel or angle conforming to bottom-section profile and allowing installation of astragal (weatherseal).
    - b. Hardware Locations: Provide reinforcement for hardware attachment.
  - 5. Thermal Insulation: Insulate interior of steel sections with door manufacturer's standard CFC-free insulation of type indicated below:
    - a. Board Insulation: Polystyrene, secured to exterior face sheet.
    - b. Fire-Resistance Characteristics: Maximum flame-spread and smoke-developed indexes of 75 and 450, respectively, in accordance with ASTM E84.
- F. Track: Manufacturer's standard, galvanized-steel, standard-lift track system. Provide complete system including brackets, bracing, and reinforcement to ensure rigid support of ball-bearing roller guides.
  - 1. Material: Galvanized steel, ASTM A653/A653M, minimum G60 zinc coating.
  - 2. Size: As recommended in writing by manufacturer for door size, weight, track configuration and door clearances indicated on Drawings.

## HERNANDO FIRE STATION #15

3. Track Reinforcement and Supports: Provide galvanized-steel members to support track without sag, sway, and vibration during opening and closing of doors. Slot vertical sections of track spaced 2 inches apart for door-drop safety device.
  - a. Vertical Track: Incline vertical track to ensure weathertight closure at jambs. Provide continuous angle attached to track and wall.
  - b. Horizontal Track: Provide continuous reinforcing angle from curve in track to end of track, attached to track and supported at points by laterally braced attachments to overhead structural members.
- G. Weatherseals: Replaceable, adjustable, continuous, compressible weather-stripping gaskets of flexible vinyl, rubber, or neoprene fitted to bottom top and jambs of door.
- H. Windows: Manufacturer's standard window units of shape and size and in locations indicated on Drawings. Set glazing in vinyl, rubber, or neoprene glazing channel. Provide removable stops of same material as door-section frames. Provide the following glazing:
  1. Insulating Glass Units: Manufacturer's standard.
- I. Hardware: Heavy-duty, corrosion-resistant hardware, with hot-dip galvanized, stainless steel, or other corrosion-resistant fasteners, to suit door type.
  1. Hinges: Heavy-duty, galvanized-steel hinges of not less than 0.079-inch nominal coated thickness at each end stile and at each intermediate stile, in accordance with manufacturer's written recommendations for door size.
    - a. Attach hinges to door sections through stiles and rails with bolts and lock nuts or lock washers and nuts. Use rivets or self-tapping fasteners where access to nuts is impossible.
    - b. Provide double-end hinges where required for doors more than 16 ft. wide unless otherwise recommended by door manufacturer in writing.
  2. Rollers: Heavy-duty rollers with steel ball bearings in case-hardened steel races, mounted to suit slope of track. Extend roller shaft through both hinges where double hinges are required. Match roller-tire diameter to track width.
    - a. Roller-Tire Material: Manufacturer's standard.
  3. Push/Pull Handles: Equip each door with galvanized-steel lifting handles on each side of
- J. Locking Device:
  1. Chain Lock Keeper: Suitable for padlock.
  2. Safety Interlock Switch: Equip power-operated doors with safety interlock switch to disengage power supply when door is locked.
- K. Counterbalance Mechanism:
  1. Torsion Spring: Adjustable-tension torsion springs complying with requirements of DASMA 102 for number of operation cycles indicated, mounted on torsion shaft.
  2. Cable Drums and Shaft for Doors: Cast-aluminum cable drums mounted on torsion shaft and grooved to receive door-lifting cables as door is raised.
    - a. Mount counterbalance mechanism with manufacturer's standard ball-bearing brackets at each end of torsion shaft.
    - b. Provide one additional midpoint bracket for shafts up to 16 ft. long and two additional brackets at one-third points to support shafts more than 16 ft. long unless closer spacing is recommended in writing by door manufacturer.
  3. Cables: Galvanized-steel, multistrand, lifting cables with cable safety factor of at least 5 to 1.
  4. Cable Safety Device: Include a spring-loaded steel or bronze cam mounted to bottom door roller assembly on each side and designed to automatically stop door if lifting cable breaks.
  5. Bracket: Provide anchor support bracket as required to connect stationary end of spring to the wall and to level the shaft and prevent sag.

## HERNANDO FIRE STATION #15

6. Bumper: Provide spring bumper at each horizontal track to cushion door at end of opening operation.
- L. Electric Door Operator: Electric door operator assembly of size and capacity recommended by door manufacturer for door and operation cycles specified, with electric motor and factory-prewired motor controls, starter, gear-reduction unit, solenoid-operated brake, clutch, control stations, control devices, integral gearing for locking door, and accessories required for proper operation.
1. Basis of Design Product: LiftMaster; Logic 5.0 Commercial Door.
  2. Comply with NFPA 70.
  3. Control equipment complying with NEMA ICS 1, NEMA ICS 2, and NEMA ICS 6; with NFPA 70, Class 2 control circuit, maximum 24 V ac or dc.
  4. Safety: Listed in accordance with UL 325 by a qualified testing agency for commercial or industrial use.
  5. Usage Classification: Standard duty, up to 25 cycles per hour and up to 90 cycles per day.
  6. Operator Type: Trolley.
  7. Motor: Reversible-type with controller (disconnect switch) for interior, clean, and dry motor exposure. Use adjustable motor-mounting bases for belt-driven operators.
    - a. Motor Size: As required to start, accelerate, and operate door in either direction from any position, at a speed not less than 8 in./sec. and not more than 12 in./sec., without exceeding nameplate ratings or service factor.
    - b. Electrical Characteristics:
      - 1) Phase: Polyphase.
      - 2) Volts: 208 V.
      - 3) Horsepower: 3/4 HP.
  8. Limit Switches: Equip motorized door with adjustable switches interlocked with motor controls and set to automatically stop door at fully opened and fully closed positions.
  9. Obstruction Detection: Automatic external entrapment protection consisting of automatic safety sensor capable of protecting full width of door opening. Activation of device immediately stops and reverses downward door travel.
    - a. Monitored Entrapment Protection: Photoelectric sensor designed to interface with door-operator control circuit to detect damage to or disconnection of sensor and complying with requirements in UL 325.
  10. Control Station: Flush mounted, three-position (open, close, and stop) control.
    - a. Operation: Push button.
    - b. Interior-Mounted Unit: Full-guarded, surface-mounted, heavy-duty type, with general-purpose NEMA ICS 6, Type 1 enclosure.
  11. Emergency Manual Operation: Chain type designed so required force for door operation does not exceed 25 lbf.
  12. Emergency Operation Disconnect Device: Hand-operated disconnect mechanism for automatically engaging manual operator and releasing brake for emergency manual operation while disconnecting motor without affecting timing of limit switch. Mount mechanism so it is accessible from floor level. Include interlock device to automatically prevent motor from operating when emergency operator is engaged.
  13. Motor Removal: Design operator so motor can be removed without disturbing limit-switch adjustment and without affecting emergency manual operation.
- M. Metal Finish: Comply with NAAMM/NOMMA's "Metal Finishes Manual for Architectural and Metal Products (AMP 500-06)" for recommendations for applying and designating finishes.
1. Baked-Enamel or Powder-Coat Finish: Manufacturer's standard baked-on finish consisting of prime coat and thermosetting topcoat. Comply with coating manufacturer's written instructions for cleaning, pretreatment, application, and minimum dry film thickness.
    - a. Color and Gloss: As selected by Architect from manufacturer's full range of industry colors and color densities.

## HERNANDO FIRE STATION #15

- N. Door Accessories: Green/Red bay door indicator light installed on the exterior.

### PART 3 - EXECUTION

#### 3.1 EXAMINATION

- A. Examine substrates, areas, and conditions, with Installer present, for compliance with requirements for substrate construction and other conditions affecting performance of the Work.
- B. Proceed with installation only after unsatisfactory conditions have been corrected.

#### 3.2 INSTALLATION

- A. Install sectional doors and operating equipment complete with necessary hardware, anchors, inserts, hangers, and equipment supports; in accordance with manufacturer's written instructions.
- B. Tracks:
  - 1. Fasten vertical track assembly to opening jambs and framing with fasteners spaced not more than 24 inches apart.
  - 2. Hang horizontal track assembly from structural overhead framing with angles or channel hangers attached to framing by welding or bolting, or both. Provide sway bracing, diagonal bracing, and reinforcement as required for rigid installation of track and door-operating equipment.
- C. Accessibility: Install sectional doors, switches, and controls along accessible routes in compliance with regulatory requirements for accessibility.
- D. Power-Operated Doors: Install in accordance with UL 325.

#### 3.3 STARTUP SERVICES

- A. Engage a factory-authorized service representative to perform startup service.
  - 1. Complete installation and startup checks in accordance with manufacturer's written instructions.
  - 2. Test and adjust controls and safety devices. Replace damaged and malfunctioning controls and equipment.

#### 3.4 ADJUSTING

- A. Adjust hardware and moving parts to function smoothly so that doors operate easily, free of warp, twist, or distortion.
- B. Lubricate bearings and sliding parts as recommended by manufacturer.
- C. Adjust doors and seals to provide weather-resistant fit around entire perimeter.
- D. Touchup Painting Galvanized Material: Immediately after welding galvanized materials, clean welds and abraded galvanized surfaces and repair galvanizing to comply with ASTM A780/A780M.

## HERNANDO FIRE STATION #15

### 3.5 DEMONSTRATION

- A. Engage a factory-authorized service representative to train Owner's maintenance personnel to adjust, operate, and maintain sectional doors.

**END OF SECTION 083610**

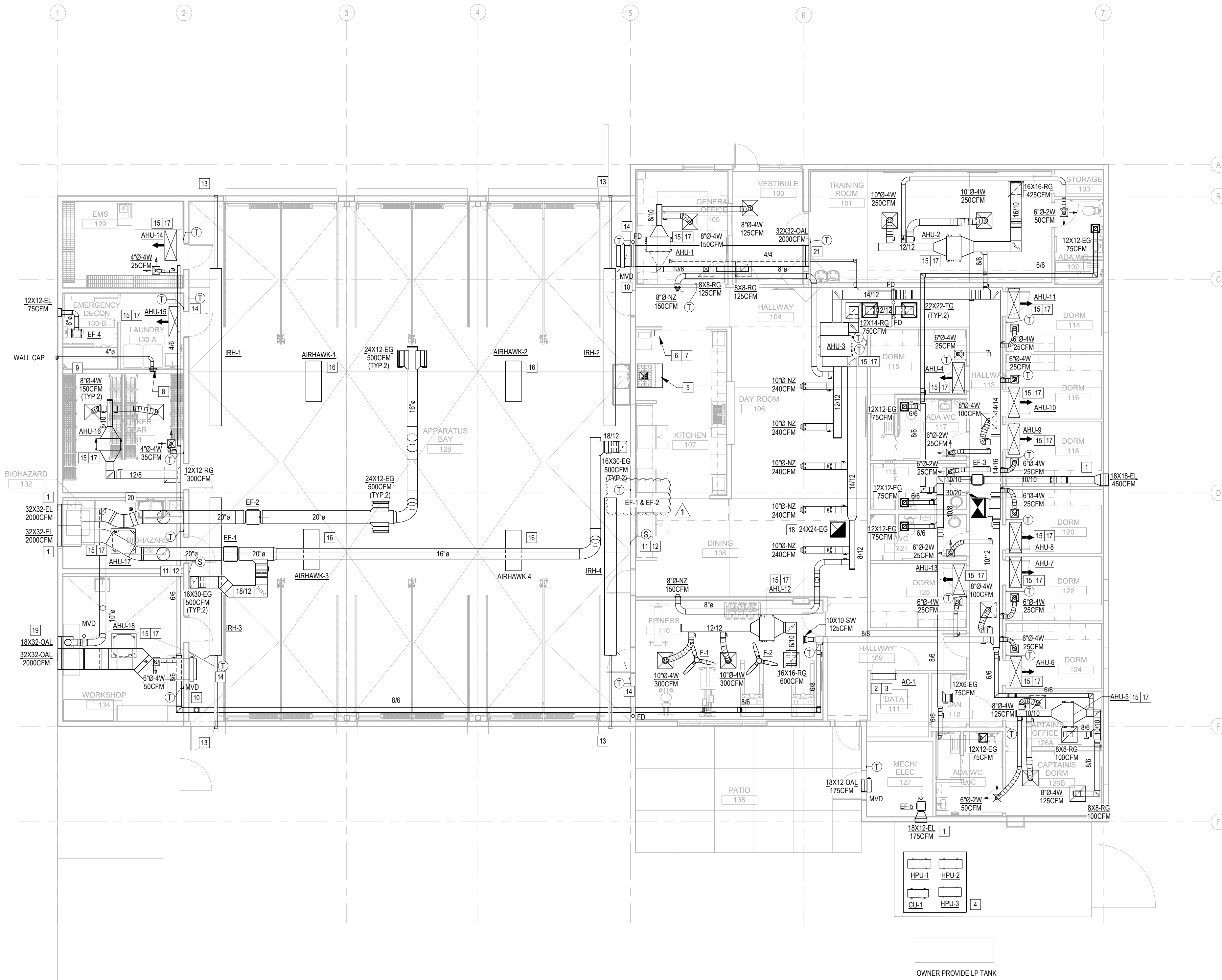

**1** GROUND FLOOR PLAN - HVAC  
1/8" = 1'-0"

**H.V.A.C. KEYNOTES [X]:**

- ROUTE EXHAUST DUCT TO WALL LOUVER. PRIME AND PAINT LOUVER TO MATCH ADJACENT SURFACES. PROVIDE WITH 1/2" MESH BIRD SCREEN. CONFIRM FINISH WITH ARCHITECTURAL TYP.
- HIGHWALL MOUNTED AC UNIT. ROUTE REFRIGERANT LINES FROM UNIT TO ASSOCIATED REMOTE MOUNTED CONDENSING UNIT. INSULATE REFRIGERANT LINES IN ACCORDANCE WITH MANUFACTURER'S REQUIREMENTS.
- ROUTE REFRIGERANT LINES FROM INDOOR UNIT LOCATION TO CONDENSING UNITS VIA UNDERGROUND PVC CHASE. CHASE SHALL BE SIZED AS RECOMMENDED BY THE MANUFACTURER. SIZE AND INSULATE THE REFRIGERANT LINES PER THE MANUFACTURER'S RECOMMENDATIONS.
- CONDENSING UNITS TO BE MOUNTED ON 4" CONCRETE SLAB. EXTEND SLAB 6" BEYOND UNIT FOOTPRINT IN ALL DIRECTIONS.
- KITCHEN HOOD WITH ROOF EXHAUST FAN. HOOD SHALL HAVE WET CHEMICAL FIRE SUPPRESSION SYSTEM WITH GAS SHUT OFF ASSEMBLY. INSTALL 5X12 CAP BY HOOD MANUFACTURER (ACCUREX). TRANSITION AS NEEDED FOR CONNECTION FROM HOOD TO ROOF EXHAUST FAN.
- KITCHEN HOOD MANUAL PULL STATION ADJACENT TO HOOD MOUNTED 48" AFF.
- INSTALL EMERGENCY CALL IN USE GAS SOLENOID RESET SWITCH.
- PROVIDE RECESSED WALL DRYER VENT BOX IN WALL TO RECEIVE DRYER VENT CONNECTION HOSE. EXTEND 4" DRYER VENT FROM VENT CONNECTOR TO WALL CAP. SEHO SERIES SFX OR APPROVED EQUAL WITH BACKDRAFT DAMPER AT EXTERIOR WALL. DRYER VENT AND CONSTRUCTION SHALL BE IN ACCORDANCE WITH SECTION 504 OF THE FBC-M. REFER TO SHEET M-601 FOR ADDITIONAL DETAILS.
- DRYER VENT TERMINATED AT THE EXTERIOR WALL. PROVIDE DRYER VENT WALL CAP. SEHO SERIES SFX OR APPROVED EQUAL WITH BACKDRAFT DAMPER.
- PROVIDE MOTORIZED DAMPER TO OPEN/CLOSE WITH APPARATUS BAY EXHAUST FAN. PROVIDE WITH 1/2" WIRE MESH BIRD SCREEN.
- PROVIDE DIESEL EXHAUST AND CO DETECTION SYSTEM FOR APPARATUS BAY. FUEL DETECTION SYSTEM SHALL HAVE OVERRIDE CONTROL ON APPARATUS BAY EXHAUST FANS. EF-1&2 SENSOR SHALL BE COMPLETELY WATER RESISTANT. MOUNT SENSOR 48" A.F.F.
- PROVIDE WITH MANUAL OVERRIDE SWITCH.
- 4" VENTS IN EITHER COMBUSTIBLE OR NONCOMBUSTIBLE WALLS. USE SEHO SERIES SFX OR APPROVED EQUAL. INSULATED VENT TERMINAL. FOLLOW THE MANUFACTURER'S INSTRUCTIONS FOR PROPER INSTALLATION AND VENT MATERIAL RECOMMENDATIONS. VENT SHALL COMPLY WITH ALL APPLICABLE FEMA CRITERIA AND SHALL BE FEMA RATED.
- HEATER SHALL BE CONTROLLED BY A LINE VOLTAGE THERMOSTAT.
- ROUTE FULL SIZE CONDENSATE DRAIN, MINIMUM 3/4", FROM COOLING COIL CONNECTION. REFER TO PLUMBING PLANS FOR CONTINUATION.
- AIR PURIFICATION FAN EQUAL TO AIRHAWK 3000XL MOUNT AT 14" AFF. COORDINATE IN FIELD.
- PROVIDE PVC CHASE FROM ELECTRICAL ROOM STUB UP TO CONDENSING UNIT PAD LOCATION. ROUTE AND TRANSITION REFRIGERANT LINES ABOVE CEILING AS REQUIRED FROM ELECTRICAL ROOM STUB UP TO EQUIPMENT SERVED. SIZE AND INSULATE PIPING PER MANUFACTURER'S RECOMMENDATION. ALL EXPOSED INSULATION ON EXTERIOR SHALL BE PROVIDED WITH ALUMINUM JACKETING.
- ROUTE AND TRANSITION DUCTWORK AS REQUIRED UP TO GRAVITY ROOF VENTILATOR. REFER TO SHEET M-206.
- PROVIDE AN OUTSIDE AIR LOUVER AND DUCTWORK TO PROVIDE MAKE-UP AIR FOR THE GEAR DRYER. ROUTE DUCTWORK TO GEAR DRYER CONNECTION IF AVAILABLE. ELSE, ROUTE TO ABOVE GEAR DRYER AND TERMINATE WITH ALUMINUM BIRD SCREEN. INTERLOCK MVD WITH GEAR DRYER OPERATION TO OPEN WHEN GEAR DRYER IS IN OPERATION AND CLOSE WHEN NOT.
- EXTEND GEAR DRYER VENT FROM GEAR DRYER TO ROOF CAP WITH BACKDRAFT DAMPER AT ROOF. GEAR DRYER VENT AND CONSTRUCTION SHALL BE IN ACCORDANCE WITH SECTION 504 OF THE FBC-M. REFER TO SHEET M-601 FOR ADDITIONAL DETAILS.
- OUTSIDE AIR LOUVER IS MOUNTED TO EXTERIOR WALL BETWEEN THE LOWER AND UPPER ROOFS. ROUTE DUCT HIGH IN CEILING CAVITY TO THE APPARATUS BAY.

**GENERAL NOTES:**

- ALL DUCTWORK SHOWN IS INTENDED TO BE ROUTED UP WITHIN THE TRUSS SPACES. THE CONTRACTOR SHALL COORDINATE THE DUCT ROUTING WITH THE TRUSS WEBBING PRIOR TO DUCT OR TRUSS FABRICATION TO ENSURE ALL DUCTWORK CAN BE PROPERLY ROUTED THROUGH THE TRUSSES.
- PROVIDE A MINIMUM 12-INCH LONG BY 0.060-INCH THICK STEEL SLEEVE FOR ALL DUCTS THAT NOT EXCEEDS 100 SQUARE INCHES PENETRATING FIRE WALLS. SLEEVE SHALL BE CENTERED IN EACH DUCT OPENING. THE SLEEVE SHALL BE SECURED TO BOTH SIDES OF THE WALL AND ALL FOUR SIDES OF THE SLEEVE WITH MINIMUM 1/2-INCH BY 1/2-INCH BY 0.060-INCH STEEL RETAINING ANGLES. THE RETAINING ANGLES SHALL BE SECURED TO THE SLEEVE AND THE WALL WITH NO. 10 (M5) SCREWS. THE ANNULAR SPACE BETWEEN THE STEEL SLEEVE AND THE WALL OPENING SHALL BE FILLED WITH ROCK (MINERAL) WOOL BATTING ON ALL SIDES.

**Wannemacher Jensen Architects, LLC.**  
132 Mirror Lake Drive North Unit #301  
St. Petersburg, Florida 33701-3214  
(727) 822-5566 fax (727) 822-5475  
www.wjarc.com  
A/R94244  
©Wannemacher Jensen Architects, LLC.

THE PROJECT'S ARCHITECT HAS REVIEWED THE MECHANICAL SYSTEMS AND HAS NOTIFIED THE ARCHITECT OF ANY CONFLICTS. THE ARCHITECT HAS REVIEWED THE MECHANICAL SYSTEMS AND HAS NOTIFIED THE ARCHITECT OF ANY CONFLICTS. THE ARCHITECT HAS REVIEWED THE MECHANICAL SYSTEMS AND HAS NOTIFIED THE ARCHITECT OF ANY CONFLICTS.

**COOPER ASSOCIATES INC.**  
MECHANICAL ENGINEERS  
1400 SOUTH WINDY HILL ROAD, SUITE 100  
WINDY HILL, MISSISSAUGA, ONTARIO L4W 1Y7  
www.cooperassociates.com  
TEL: 905.882.1111

**HERNANDO COUNTY FIRE STATION #15**  
10270 ATLANTA AVENUE BROOKSVILLE, FL 34614

Project number	24021
DISTRIBUTION	
MILESTONE	DATE
PERMIT SET	12/12/25
ADDENDUM A	03/04/26

GROUND FLOOR PLAN - HVAC

M-101

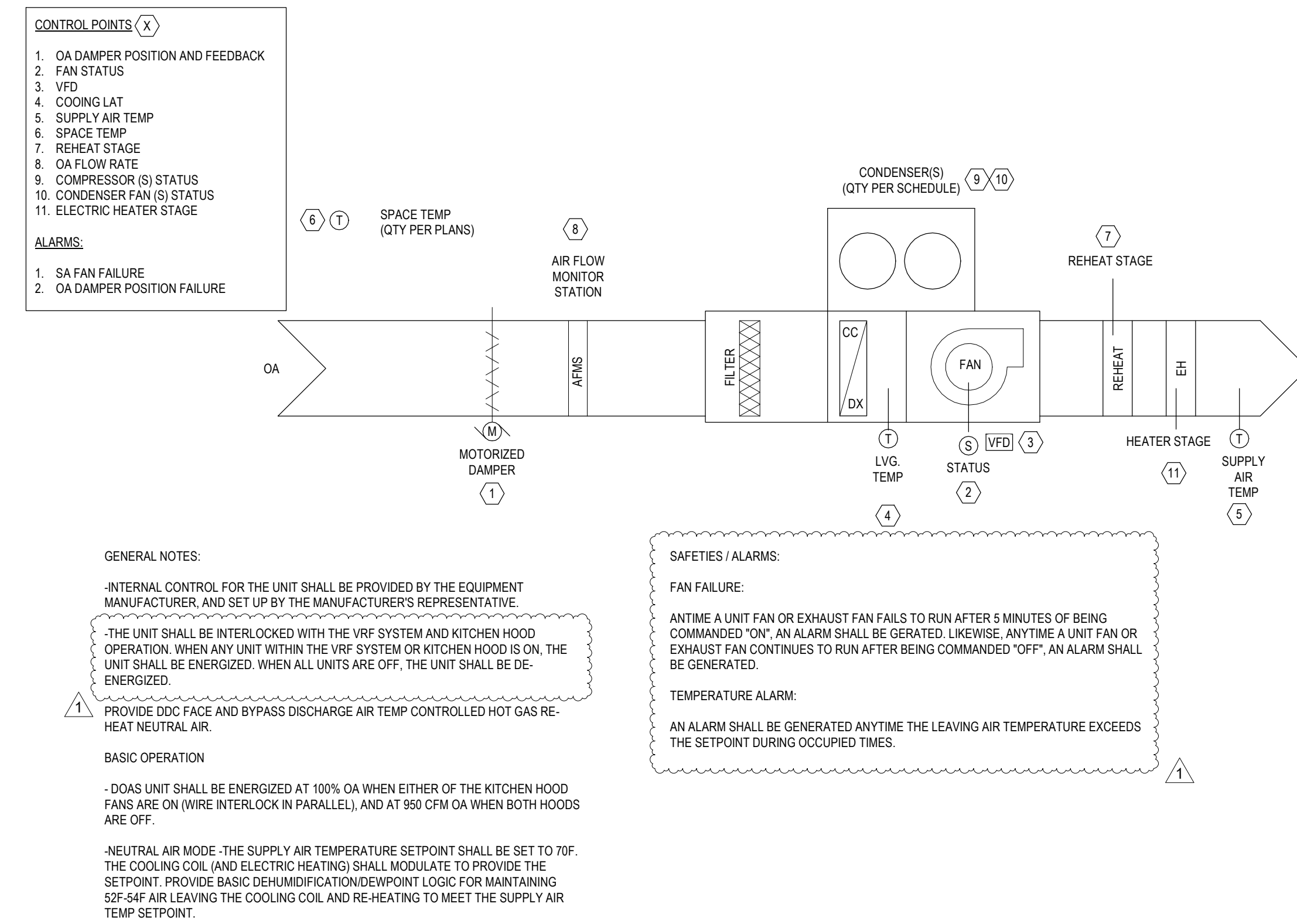

1 CONTROLS - DOAS AHU CONTROL SCHEMATIC

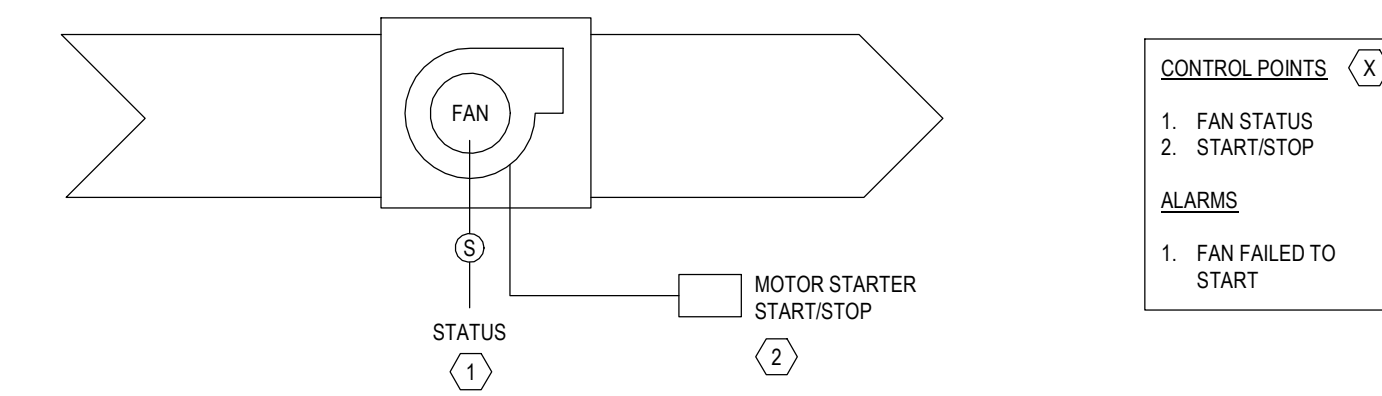

**FAN EF-3 INTERLOCKED WITH DOAS UNIT:**

WHEN DOAS UNIT IS IN OCCUPIED MODE, THE FAN SHALL BE ENERGIZED. WHEN THE UNIT IS IN UNOCCUPIED MODE THE FAN SHALL BE DE-ENERGIZED.

**APPARATUS BAY FAN - EF-1 & EF-2**

SEE EMERGENCY VENTILATION SYSTEM CONTROL SCHEMATIC.

**FAN EF-4 INTERLOCKED WITH OCCUPANCY SENSOR:**

NO CONTROL OR STATUS ARE REQUIRED FOR ANY SMALL FAN INDICATED TO BE INTERLOCKED WITH OCCUPANCY SENSOR FOR CONTROL. UNLESS NOTED OTHERWISE, ALL EXHAUST FANS SHALL BE INTERLOCKED WITH THE FIRE ALARM SYSTEM TO SHUT DOWN UNDER FIRE ALARM CONDITION.

2 CONTROLS - TYPICAL EXHAUST FAN CONTROL SCHEMATIC

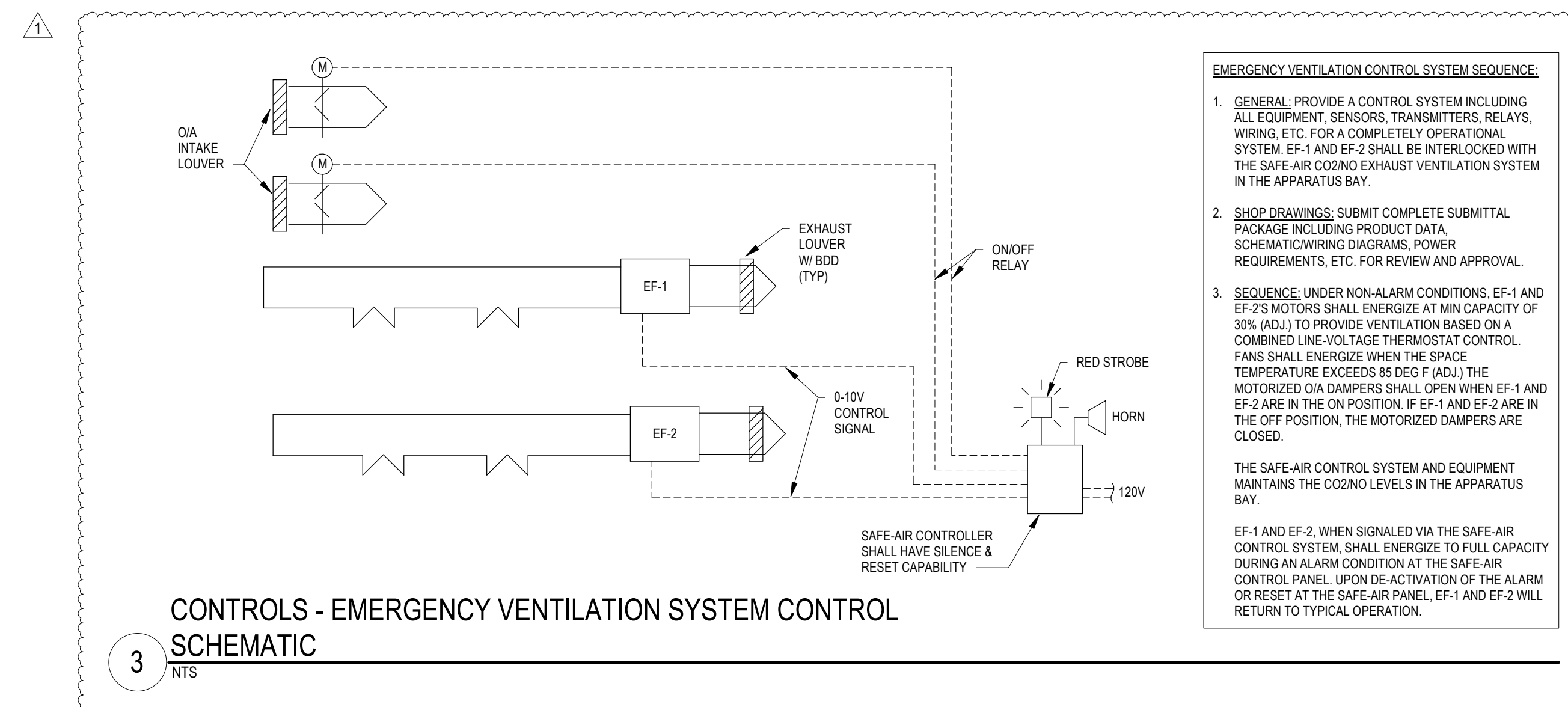

3 CONTROLS - EMERGENCY VENTILATION SYSTEM CONTROL SCHEMATIC

Project number	24021
DISTRIBUTION	
MILESTONE	DATE
PERMIT SET	12/12/25
ADDENDUM A	03/04/26



## ADDENDUM # SIX (6)

TO  
THE CONTRACT DOCUMENTS  
FOR THE

Construction of Fire Station 15

IN  
HERNANDO COUNTY, FLORIDA

**SOLICITATION NO. 26-C01265/GB**

Bidders are required to acknowledge receipt of this Addendum via OpenGov prior to the time of the Bid Opening.

The following changes, additions are hereby made a part of the Contract Documents for the above-referenced Solicitation as fully and completely as if the same were fully set forth therein:

### **I. Questions and Answers**

**58.Q. For the Smoke and Carbon Dioxide (CO) detectors in hallway of bunk sleeping units do you want combination Smoke CO detectors or as separate initiating devices Smoke / CO detectors? Combination units as less costly due to less wire and labor required.**

58.A. CMTA takes no exceptions to combo smoke/CO detectors in bunk corridor where location of Combo units is within proximity to each bunk room as required by Florida Statute 553.885.

**59.Q. Do the sleeping bunks require CO detection as well? They are not notated in the bunks (only hallways) and from previous Fire Stations experience and knowledge CO are required in the bunks.**

59.A. NFPA 101 26.3.4.5.1 requires smoke detectors in bunks. CO detectors in bunks require AHJ approval.

**60.Q. Per Fire Alarm Legend – Is CE Control Element the same as Control Relay? I'd think yes but don't want to make a wrong assumption since RR Control relay is also notated in the legend. CE is marked on Note 6 Airhawk AHUs and Note 8 Generator.**

60.A. Control Element & Control Relay have different functions. Control element is the logical component which controls/processes the signal. The Control relay is the physical relay switch.

**61.Q. For H magnetic door release per code mag lock door release is a code requirement. Need to know if they need release at door location or per the security system location release as this will make a difference in counts.**

61.A. Mag lock door release is a code requirement and shall be installed at all door location building exits.



## PROCUREMENT DEPARTMENT

15470 FLIGHT PATH DRIVE ♦ BROOKSVILLE, FLORIDA 34604  
P 352.754.4020 ♦ F 352.754.4199 ♦ W [www.HernandoCounty.us](http://www.HernandoCounty.us)

- 62.Q. Sleeping bunks show 120 Volt smokes. To ensure the low frequency sounder trips notification if the 120V smoke goes off it would require a monitor module output to be provided by the EC on 120 v smoke. Fire Alarm could tie the low frequency sounder notification tripping with a relay connection for smoke detection in room. The best and less costly way to do so is system sensors smokes that that snap in a Low Frequency sounder base. Please Advise which way is required.**
- 62.A. CMTA takes no exception to UL listed low frequency sounder base.
- 63.Q. Spec Section 2.2 Temporary Facilities - Offices. Please clarify if the architect will be required to have a temp. office onsite as stated in the specification so it can be accounted for in the temp. trailer rental pricing.**
- 63.A. Refer to Addendum 5, 49.A. The specifications have been removed from the project.
- 64.Q. Is Cummins an accepted manufacturer for both the generator and ATS?**
- 64.A. Cummins generator is not an acceptable manufacturer. Blue star power system and control system is an additional approved manufacturer.
- 65.Q. Can the engineer please share the generator sizing report? Or an explanation of how generator size was calculated?**
- 65.A. Generator previously sized for MDP + Fire Pump. Refer to Attachment 5 – E-601 Revised generator from 350KW to 250KW.
- 66.Q. What is the purpose of the “spare” breaker on the generator?**
- 66.A. The spare breaker has been provided for Owner equipment as necessary.
- 67.Q. Please identify fence specs such as post sizes, top-rail, cable wire & wire selvage.**
- 67.A. Refer to Addendum 5, 53.A. Perimeter fencing is not required for this project.
- 68.Q. The specification calls for an EST4 fire alarm system on page 376-437, in lieu of an EST4 will a Siemens FC922/924 be an acceptable option?**
- 68.A. Siemens is not an acceptable manufacturer.
- 69.Q. Contract drawing E-001 does not specify the candela rating for the visual, need more information.**
- 69.A. 75CD for indoors, 110CD in App Bay or as determined by Fire Alarm Shop Drawings.
- 70.Q. Is there a fuel tank required?**
- 70.A. Fuel tank required to satisfy Owner criteria of 24 Hour run time @ 100% load. Refer to Attachment 6 – E-601, added note for alternative owner option for 499-gallon tank maximum, final determination by Owner.
- 71.Q. Please identify location and layout of traffic coatings. Is it to be in the Apparatus Bay?**
- 71.A. Traffic coatings are removed from the project scope.
- 72.Q. TV-1,2,3 are noted in the Equipment Schedule as owner furnished owner installed. Please provide clarity, quantity and location of the LED Displays described in 109050 spec as Microframe Corporation; Model 6300.**
- 72.A. The LED display referenced in Specification Section 10 90 50 corresponds to the TM-6-Digit Countdown Timer Display by Microframe Corporation. Please refer to Sheet ID-301 and Sheet A-501 for the location and installation.



## PROCUREMENT DEPARTMENT

15470 FLIGHT PATH DRIVE ♦ BROOKSVILLE, FLORIDA 34604  
P 352.754.4020 ♦ F 352.754.4199 ♦ W [www.HernandoCounty.us](http://www.HernandoCounty.us)

- 73.Q. Please provide quantity and location for the FRP Basis of Design Aickinstrut; Nonmetallic Channel Framing System per 109050 spec.**
- 73.A. The FRP Aickinstrut Nonmetallic Channel Framing System is removed from the project scope.
- 74.Q. Testing Agency: An independent testing agency shall be provided by the CONSTRUCTION MANAGER (CM). Can you please clarify who is the Construction Manager?**
- 74.A. An independent testing agency shall be provided by the owner.
- 75.Q. Is the owner providing the Fire Station Alerting System? Please clarify the contractor's scope of work.**
- 75.A. Alerting system is not required. Contractor's responsibility shall be furnishing and installing speakers, wiring, and amplifier. County to furnish and install alerting radio and County shall be responsible for tying in their radio to the amplifier and overhead paging system. Specification 285500 shall be removed from this contract.
- 76.Q. Equipment Schedule, Sheet A-408: Please identify the responsibilities for supply and install of the equipment on the schedule that are missing (Kitchen Class Portable Fire Extinguisher, CH Coat Hook, M-2 Alum. Bench, PTD Paper Towel Dispenser, SC Shower Curtain, SCR Shower Curtain Rod, SD Soap Dispenser & TTD Recessed Toilet Tissue Holder)**
- 76.A. It is the Contractor's responsibility.
- 77.Q. Plan Sheet ID-101: Please provide specified material for EPF-1 for pricing. Finish Identification is missing from callouts below on the same sheet.**
- 77.A. DESCRIPTION: EPOXY FLOORING, MANUFACTURER: SIKA, STYLE: SIKAFLOOR NA24 PURCEM SELF LEVELING BROADCAST SYSTEM, REMARKS: PROVIDE INTEGRAL COVE BASE, CONTACT: JASON FOWLER (239) 810-1585 [JFOWLER@DEKSCAPE.COM](mailto:JFOWLER@DEKSCAPE.COM)
- SS-2 DESCRIPTION: SOLID SURFACE, MANUFACTURER: CORIAN, COLOR: CARBON CONCRETE
- 78.Q. The Testing Laboratory will test the structural steel for compliance with AISC Specifications for the design, fabrication, and erection of the structural steel for buildings. By the owner: please confirm.**
- 78.A. Confirmed. The testing laboratory will be provided by the owner.
- 79.Q. Please confirm if Snaplock is acceptable for the low pressure round duct.**
- 79.A. Per the ductwork schedule note 3 on M-601, Snaplock ductwork is not permitted.
- 80.Q. Project manual contains section 234324 Air Purification, but Bipolar Ionization is not mentioned in the plans. Is bipolar ionization needed?**
- 80.A. No. Bipolar ionization is removed from the specifications.
- 81.Q. CWT-1 calls for 2x2 mosaic wall tile (normally used for shower floors), PFT-1 doesn't state size, but normally the 2x2 mosaic is used, BASE TILE - No stated finish height. Please confirm all.**



## PROCUREMENT DEPARTMENT

15470 FLIGHT PATH DRIVE ♦ BROOKSVILLE, FLORIDA 34604  
P 352.754.4020 ♦ F 352.754.4199 ♦ W [www.HernandoCounty.us](http://www.HernandoCounty.us)

- 81.A. Use 2"x2" mosaic tile throughout for the tile types referenced. Tile heights shall be as follows: Full height at shower walls, 6'-0" AFF at wet walls. Refer to Sheets A-401, A-402, A-403, A-407, and A-409 for additional information.
- 82.Q. Please confirm if we are using colored masonry on this job, as the spec book only has one reference to the basis of design, but it has no details for color or mortar color.**
- 82.A. No colored masonry.
- 83.Q. Spec 10 14 26 indicates Post and Panel Signage. Please indicate location and dimensions.**
- 83.A. Refer to the Site Plan on the Civil and Architectural drawings for the signage location. Refer to Detail 3 on Sheet A-002 for signage dimensions and configuration.
- 84.Q. Would Watchfire be accepted as a substitute manufacturer?**
- 84.A. If Watchfire is not listed as an approved manufacturer in the project specifications, the Contractor shall submit a substitution request in accordance with the substitution procedures specified in the contract documents for review by the design team.
- 85.Q. Please accept Daltilo as a substitute manufacturer.**
- 85.A. If Daltilo is not listed as an approved manufacturer in the project specifications, the Contractor shall submit a substitution request in accordance with the substitution procedures specified in the contract documents for review by the design team.
- 86.Q. Question #33 Response Clarification: We respectfully request that the stipulation requiring the Contractor to self-perform 15% of the project be removed in its entirety. This requirement effectively excludes qualified Construction Management (CM) firms from participating, as true CM firms provide project management, coordination, and supervision services rather than directly self-performing trade work. The CM delivery model is specifically structured around managing subcontracted trade partners while maintaining full responsibility for project execution, schedule, cost control, and quality assurance. The self-performance requirement appears to reflect a traditional general contracting qualification structure and does not align with the Construction Management delivery method. Maintaining this stipulation unnecessarily restricts competition creating an unfair advantage to other firms and limits the Owner's access to experienced CM firms that are suited for this type of work. For these reasons, we respectfully request that the 15% self-performance requirement be removed to allow full participation by all qualified CM firms.**
- 86.A. The 15% self-performance requirement is removed.
- 87.Q. There is a conflict with the drywall requirements. The wall type F calls for "Sound Break" drywall. Note 4 on A800 calls for Abuse resistant drywall to 8' aff on all walls. They do not make a sound break abuse resistant drywall. What would be the correct material? Both come as XP moisture resistant.**
- 87.A. Provide Sound Break gypsum board where indicated by the wall type (Wall Type F). At locations where a Sound Break gypsum board is not specifically required, provide abuse-resistant gypsum board up to 8'-0" A.F.F. in accordance with Note 4 on Sheet A800.



## PROCUREMENT DEPARTMENT

15470 FLIGHT PATH DRIVE ♦ BROOKSVILLE, FLORIDA 34604  
P 352.754.4020 ♦ F 352.754.4199 ♦ W www.HernandoCounty.us

- 88.Q. Landscaping drawing L1 indicates that designated natural vegetation areas should remain undisturbed by all construction related activities. But Electrical drawing E-010 shows the new underground electrical utility line going through this area. Does the utility line need to be rerouted to avoid disturbing this area? Please clarify on this design conflict.**
- 88.A. Conduit lines on sheet E-010 are a diagrammatical depiction representing connections between powered electrical gear. Contractor shall determine exact routing on-site. Refer to General Note #1 Sheet E-010.
- 89.Q. Ladders show vertical members as galvanized steel and wall anchorage brackets as powder-coated steel. Ladder rungs are aluminum. Can we fabricate ladders out of steel and have them galvanized? We don't recommend using dissimilar metals, as steel will cause the aluminum to corrode.**
- 89.A. Provide ladder fully fabricated in aluminum to avoid dissimilar metals.
- 90.Q. Door 112 is listed as Type K., but there is no elevation for a Type K door. Can you provide the type K door elevation?**
- 90.A. Door 112 shall be Type B. Refer to the Type B door elevation.
- 91.Q. We just became aware of the project and noticed the pre-bid meeting has already taken place. Would it still be possible for us to submit pricing?**
- 91.A. Refer to Section 2.2. Mandatory Pre-Bid Conference. Attendance at mandatory pre-bid meetings is required for prime contractors. Subcontractors may provide pricing to any prime contractors that attended the pre-bid meeting.

### II. Changes

- 64.A. Adds Blue star power system and control system as an acceptable manufacturer.
- 65.A. Adds Attachment 5 – Revised E-601 - Revised generator from 350KW to 250KW
- 70.A. Adds Attachment 5 – Revised E-601 - Added note for alternative owner option for 499-gallon tank maximum, final determination by Owner.
- 86.A. Removes the 15% self-perform level from contract and changes the response on Addendum #3, 33.A.

### III. Attachments

- Attachment 5 – Revised E-601

## BOARD OF COUNTY COMMISSIONERS OF HERNANDO COUNTY, FLORIDA

Felicia Holmes, CPPO, CPPB, NIGP-CPP

For: Carla Rossiter-Smith MSM, PMP, GPC  
Chief Procurement Officer





## ADDENDUM # SEVEN (7)

TO  
THE CONTRACT DOCUMENTS  
FOR THE

Construction of Fire Station 15

IN  
HERNANDO COUNTY, FLORIDA

**SOLICITATION NO. 26-C01265/GB**

Bidders are required to acknowledge receipt of this Addendum via OpenGov prior to the time of the Bid Opening.

The following changes, additions are hereby made a part of the Contract Documents for the above-referenced Solicitation as fully and completely as if the same were fully set forth therein:

### I. Questions and Answers

**91.Q. For H magnetic door release per code mag lock door release is a code requirement. Need to know if they need to be releases at door location or per the security system location release as this will make a difference in counts.**

91.A. Code requires the motion sensor above the door and the push button on the wall as the secondary release as noted in the hardware set.

**92.Q. Section 8. Pricing Proposal: Owner needs to specify: Diameter of the drill and Compressive strength of the grout.**

92.A. Grout injection pipes shall be made of approved flush joint steel threaded pipe with a minimum of two- and one-half inch (2.5") and a maximum of four-inch (4") inside diameter. The pipes shall be of sufficient strength and rigidity to withstand all installation stresses, to prevent distortion caused by placing adjacent grout points, and to prevent collapse due to soil or hydrostatic pressure. The diameter of grout hoses and other ancillary fittings shall be of an adequate diameter to permit injection of the grout mix anticipated without undue loss of head due to hydraulic friction, but in no case shall they have less than a two-inch (2") inside diameter.

Grout shall consist of a mixture of Portland cement, a pozzolanic material when approved by the consultant, fluidizer, fine aggregate, and water proportioned and mixed to produce a grout capable of being pumped with a slump of 1- to 4-inches without "sand-blocking". The grout shall have a minimum compressive strength of 200 psi. at 48 hours. Admixtures shall not be used unless APPROVED BY THE



## PROCUREMENT DEPARTMENT

15470 FLIGHT PATH DRIVE ♦ BROOKSVILLE, FLORIDA 34604  
P 352.754.4020 ♦ F 352.754.4199 ♦ W www.HernandoCounty.us

CONSULTANT. The contractor shall be solely responsible for the mix design, pumpability, strength, etc.

- 93.Q. Addendum 1, Question 5 said that access control will not be installed on this project. Addendum 3 said that access control is provided by the owner and contractors are to include boxes and raceways. Hardware Schedule on A-810 lists certain hardware as an ADD ALT. Please clarify what door hardware is to be included in the base bid.**
- 93.A. Access control equipment is not included in this project and will be installed by the Owner. The Contractor shall provide conduit, raceways, boxes, and door preparation for future access control installation as indicated on the drawings. Future access control provisions shall also be included for Doors 110B, 128B, and 128A. Hardware identified as \*\*Add Alternate in the Hardware Schedule is not included in the Base Bid.
- 94.Q. Are we to provide a deduct alternate to remove the panic hardware? What hardware is to be used to replace the panic devices?**
- 94.A. Panic devices are to remain and are required for the project by code. The deduct alternate to remove panic hardware is not applicable. No replacement hardware selection is needed. The specified hardware sets shall remain as currently indicated:
- Door 100: Hardware Set #01
  - Door 109: Hardware Set #02
  - Door 128C: Hardware Set #04
- 95.Q. Landscape Plans L3; Well Identification: Please provide the recommended depth of the shallow well so all are pricing the same scope of work.**
- 95.A. Contractor shall include an irrigation well based on an assumed depth range of 100 to 150 feet, derived from available nearby well records. Final well depth, casing depth, and related well construction requirements shall be determined by the licensed well contractor based on actual field conditions, required production, and permit requirements.
- 96.Q. The specifications for the keying on page 279 / 2.4 say to provide construction cores for the locks indicating that the owner will be using removable cores. The exterior hardware sets are written with removable cores, but the interior sets (ex. HDW5) are written with conventional, non-removable cores. Can you clarify if the interior doors should have removable cores or conventional keying?**
- 96.A. Removable cores are for the panic hardware and devices only. All other locks, including interior door hardware sets, shall be provided with conventional (non-removable) cores.
- 97.Q. The Raynor Manufacturer stated, "We can requote this as SP20; however, please note the SP20 Florida approvals are still in process, and not all configurations are available back yet. At this time, the best approved wind load I can offer on SP20 is as follows: Florida Approval: FL47394 Impact Approval: P-3356 Design Load: +30.9 / -33.1 Configuration includes 3 mutts per section One glass section in section #3 Please compare this against the required project design pressures and Florida approval requirements on your end and let me know if this will satisfy the job requirements."**



## PROCUREMENT DEPARTMENT

15470 FLIGHT PATH DRIVE ♦ BROOKSVILLE, FLORIDA 34604  
P 352.754.4020 ♦ F 352.754.4199 ♦ W www.HernandoCounty.us

97.A. Please note that the Raynor overhead door shall use Florida Product Approval FL47394 (Impact Approval P-3356).

The Florida Approval currently referenced in the drawings is no longer applicable and should be replaced with FL47394 to match the approved SP20 configuration and design pressures.

98.Q. The deck has a common specification "REMOVABLE PLATE". What exactly does that refer to? Please confirm if these signs are not supposed to be affixed to the wall with a VHB adhesive but rather with a bracket that allows the sign to be removed from the wall. Please clarify. • Is this material clear or (I'm assuming) White? • If this is clear, did you want second surface print with ADA raskars on top? • Material thickness? I'm thinking .125" but please confirm.

98.A. Please disregard the note indicating a removable plate with bracket system. Provide signage as non-removable, adhesive-mounted (double foam tape as required). Signs shall be 1/8" thick and solid matte acrylic in black, with raised copy and braille for ADA compliance.

### II. Changes

Attachment 6 – Electric Water Heater - EWH-1

Attachment 7 - Smart wire Access Control Cable Door Zone

### BOARD OF COUNTY COMMISSIONERS OF HERNANDO COUNTY, FLORIDA

A handwritten signature in cursive script that reads "Felicia Holmes".

For: Carla Rossiter-Smith MSM, PMP, GPC  
Chief Procurement Officer

### GOLD SERIES COMMERCIAL ELECTRIC WATER HEATER

Designed for use as a recovery heater having its own storage tank.  
Note: Not recommended for sanitizing water applications.

#### FEATURES

- Meets the standby loss requirements of the U.S. Department of Energy and current edition of AHRAE/IES 90.1

#### INCOLOY ELEMENTS

- Heavy-duty medium watt density elements have incoloy sheathing: provide excellent protection against oxidation and scaling.

#### GLASSLINED TANK

- Three sizes: 50, 80 and 119 gallon capacity. Tank interior is coated with glass specially developed by A. O. Smith for water heater use. Tanks rated at 150 PSI (1034 kPa) working pressure

#### FUSING

- Protects all elements, thermostats, and internal wiring circuits against excess current flow. Meets National Electrical Code requirements that non-ASME tanks must have internal fusing when current draw exceeds 48 amps. Available as an option on Canadian built heaters.

#### STANDARD VOLTAGES

- 208, 240 and 480V single-phase and three-phase delta. Convertible from three-phase to single-phase (in field) and vice versa. 277V single-phase also available.

#### TERMINAL BLOCK

- Factory installed. Just bring the electrical service to the heater and connect to block.

#### CONTROLS

- One temperature control (adjustable through a range of 120° to 181°F) and manual reset high temperature cut-off per element. Thermostat step control may be achieved by varying settings on individual temperature controls. Located behind hinged control compartment door for quick, easy access.

#### OTHER STANDARD FEATURES

- Surface mounted thermostats
- Simplified circuitry, color coded for ease of service
- Two anode rods for maximum corrosion protection
- Cabinet has bonderized undercoat with baked enamel finish
- Bottom inlet and top outlet openings
- Brass drain valve
- CSA Certified and ASME rated T&P relief valve
- Single panel control box
- Foam insulation reduces costly heat loss.

#### 3-YEAR LIMITED TANK / 1-YEAR LIMITED PARTS WARRANTY

- For complete warranty information, consult written warranty or go to [hotwater.com](http://hotwater.com)



MODELS  
DRE-52, 80, 120



OPTIONAL



## OPTIONS

- UL and cUL listed conversion kits to adjust voltage and kW requirements in the field before and after installation
- ASME 160 psi (1103 kPa) tank construction
- International voltages – 220, 380, 400, 415, 575, and 600 volts, three phase available with Y connected elements
- MANIFOLD KITS – for multiple tank installations. Two heaters -part # 100109231, three heaters- part # 100109232 and four heaters- part # 100109233

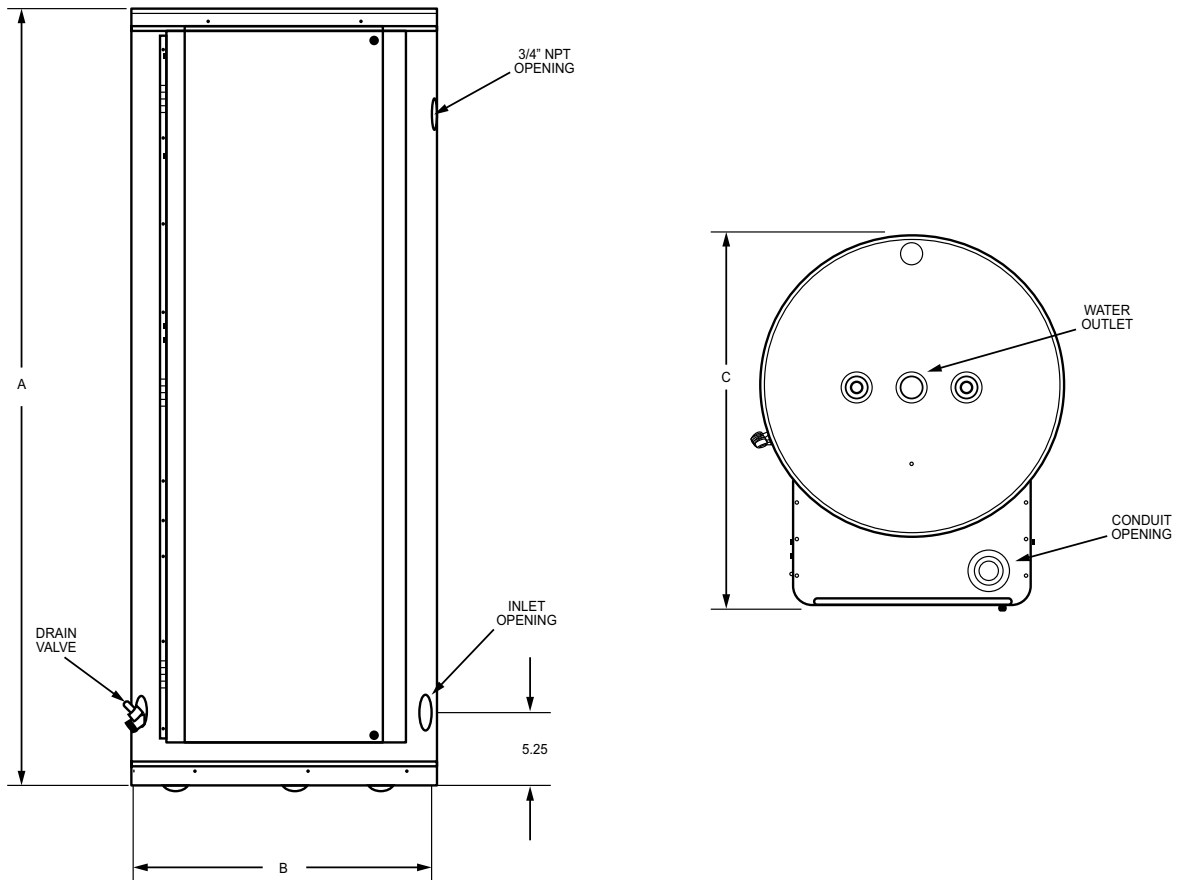

## DIMENSIONS

Model Number	Tank Capacity		Dimensions						Inlet/Outlet (NPT)	Approx. Shipping Weight	
			A		B		C				
	gal.	litre	Inches	MM	Inches	MM	Inches	MM	Inches	lbs	kG
DRE-52	50	189	55-3/4	142	21-3/4	55.2	27	68.6	1-1/4	265	120
<b>EWH-1</b> DRE-80	80	302	60-1/4	153	25-1/2	64.8	31	78.7	1-1/4	280	127
<b>EWH-2</b> DRE-120	119	450	62-1/4	158.1	29-1/2	75	35	88.9	1-1/4	390	177

For ASME Construction add "A" to the model number (example: DRE 52A 24).



# Commercial Electric Water Heaters

## RECOVERY RATE IN GALLONS PER HOUR AT TEMPERATURE RISE OF

Standard kW Input	BTU/ Hour	30°F	40°F	50°F	60°F	70°F	80°F	90°F	100°F	110°F	120°F	130°F	140°F
		17°C	22°C	28°C	33°C	39°C	45°C	50°C	56°C	61°C	67°C	72°C	78°C
EWH-1 & 2 12.3	41,980	168	126	101	84	72	63	56	50	46	42	39	36
		636	477	382	318	273	238	212	189	174	159	148	136
13.5	46,075	184	138	111	92	79	69	62	55	50	46	43	40
		698	523	419	349	299	262	233	209	190	174	161	150
15	51,195	205	154	123	102	88	77	68	61	56	51	47	44
		775	582	465	388	332	291	258	233	211	194	149	166
18	61,434	246	184	148	123	105	92	82	74	67	62	57	53
		930	698	558	465	399	349	310	279	254	233	215	199
24	81,912	328	246	197	164	140	123	109	98	90	82	76	70
		1241	930	744	620	532	465	414	372	338	310	286	266
27	92,151	369	276	221	185	158	138	123	111	101	92	85	79
		1396	1047	938	609	509	523	465	410	391	340	322	299
30	102,390	410	307	246	205	176	154	137	123	112	102	95	88
		1551	1163	930	775	665	582	517	465	423	388	358	332
36	122,868	492	369	295	246	211	184	164	148	134	123	113	105
		1861	1396	1117	930	798	698	620	556	508	465	429	399
40.5	138,226	554	418	332	277	237	208	185	166	151	138	128	119
		2094	1570	1256	1047	897	785	698	628	634	582	537	498
45	153,585	615	461	369	307	263	230	205	184	168	154	142	132
		2326	1745	1398	1163	997	872	755	698	634	582	537	498
54	184,302	738	554	443	359	316	277	246	221	201	185	170	158
		2791	2094	1675	1396	1196	1047	930	837	761	696	644	598

Figured at 1 kW (3413 BTU) = 4.1 Gallons at 100°F temperature rise.



# Commercial Electric Water Heaters

kW Input	Model Numbers Tank Capacity in Gallons			Number of Elements	Element Wattage	Full Load Current in Amperes						
						Single Phase				Three Phase		
	50	80	119			208V	240V	277V	480V	208V	240V	480V
12.3	DRE-52-12	DRE-80-12	DRE-120-12	3	4,100	59	51	44	26	34	30	15
13.5	DRE-52-13.5	DRE-80-13.5	DRE-120-13.5	3	4,500	64.9	56.3	48.7	28.1	37.5	32.5	16.2
15	DRE-52-15	DRE-80-15	DRE-120-15	3	5,000	72.1	62.5	54.2	31.3	41.6	36.1	18
18	DRE-52-18	DRE-80-18	DRE-120-18	3*	6,000	86.5	75	65	37.5	50	43.3	21.7
24	DRE-52-24	DRE-80-24	DRE-120-24	6	4,000	115.4	100	86.6	50	66.6	57.7	28.9
27	DRE-52-27	DRE-80-27	DRE-120-27	6	4,500	129.8	112.5	97.5	56.3	74.9	65	32.5
30	DRE-52-30	DRE-80-30	DRE-120-30	6	5,000	144.2	125	108.3	62.5	83.3	72.2	36.1
36	DRE-52-36	DRE-80-36	DRE-120-36	6*	6,000	173.1	150	130	75	99.9	86.6	43.3
40.5	N/A	DRE-80-40.5	DRE-120-40.5	9	4,500	194.7	168.8	146.2	84.4	112.4	97.4	48.7
45	N/A	DRE-80-45	DRE-120-45	9	5,000	216.3	187.5	162.5	93.8	124.9	108.3	54.1
54	N/A	DRE-80-54	DRE-120-54	9	6,000	N/A	225	194.9	112.5	149.9	129.9	65

\*208 volt models may contain three (3) additional elements.  
For ASME Construction add "A" to the model number (example: DRE 52A 24).

## SUGGESTED SPECIFICATION

The heater(s) shall be Gold Series Commercial Electric Model Number \_\_\_\_\_ as manufactured by A. O. Smith. Heater(s) shall be rated at \_\_\_\_\_ kW, \_\_\_\_\_ volts, \_\_\_\_\_ phase, 60 cycle AC, and listed by Underwriters' Laboratories and approved to the NSF Standard 5 by UL. Tank(s) shall be \_\_\_\_\_ (50, 80 or 119) gallon capacity. Tanks shall have \_\_\_\_\_ (150 [Std] or 160 [ASME]) psi working pressure and be equipped with extruded high density anode. All internal surfaces of the heater(s) exposed to water shall be glasslined with an alkaline borosilicate composition that has been fused-to-steel by firing at a temperature range of 1400°F to 1600°F. Electric heating elements shall be low watt density. Each element shall be controlled by an individually mounted thermostat and high temperature cut-off switch. All internal circuits shall be fused. The outer jacket shall be of baked enamel finish and shall be provided with full size control compartment for performance of service and maintenance through hinged front panel and shall enclose the tank with foam insulation. Electrical junction box with heavy duty terminal block shall be provided. The drain valve shall be located in the front for ease of servicing. Heater tank shall have a three year limited warranty as outlined in the written warranty. Manufacturer shall supply ASME rated temperature and pressure relief valve. Fully illustrated instruction manual to be included. Meets standby loss requirements of the U. S. Department of Energy and current edition of ASHRAE/IES 90.1.

For technical information, call 800-527-1953. A. O. Smith Corporation reserves the right to make product changes or improvements without prior notice.

**PART NUMBER 4461030**

UL Listed and Rated Type CMP Plenum Composite Cable

■ 0275/0725 FT ● SMARTWIRE ACCESS CONTROL CABLE DOOR/ZONE A B C D E 0 1 2 3 4 5 6 7 8 9

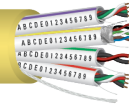
**CABLE SPECIFICATIONS**

<b>DESCRIPTION</b>	Elem1:18 AWG 4 Conductor Bare Copper White Jacket with Purple Stripe; Elem2:22 AWG 3 Pair OAS Bare Copper White Jacket with Yellow Stripe; Elem3:22 AWG 2 Conductor Bare Copper White Jacket with Green Stripe; Elem4:22 AWG 4 Conductor Bare Copper White Jacket with Red Stripe Plenum Composite Cable, C(UL)US CMP
<b>CONDUCTOR</b>	Element 1: 18 AWG 7 Strand Bare Copper; Element 2, 3, and 4: 22 AWG 7 Strand Bare Copper
<b>INSULATION</b>	All Elements: .008" Low Smoke PVC
<b>COLOR CODE</b>	Element 1: Black/Red/White/Green Element 2: Black/Red; White/Green; Brown/Blue Element 3: Black/Red Element 4: Black/Red/White/Green
<b>SHIELD</b>	Element 1,3, & 4: N/A; Element 2: Overall Aluminum Mylar
<b>DRAIN WIRE</b>	Element 1,3 & 4: N/A; Element 2: 24 AWG 7 Strand Tinned Copper
<b>JACKET</b>	Inner Jackets: All Elements: Low-Smoke PVC .018"; Outer Jacket: Low-Smoke PVC .020"
<b>JACKET COLOR</b>	Yellow Jacket
<b>MARKING</b>	Elem1: LOCK POWER A B C D E 0 1 2 3 4 5 6 7 8 9; Elem2: CARD READER A B C D E 0 1 2 3 4 5 6 7 8 9; Elem3: DOOR CONTACT A B C D E 0 1 2 3 4 5 6 7 8 9; Elem4: REX/SPARE A B C D E 0 1 2 3 4 5 6 7 8 9 Outer Jacket: SMARTWIRE ACCESS CONTROL CABLE DOOR / ZONE A B C D E 0 1 2 3 4 5 6 7 8 9 C(UL)US CMP ROHS MADE IN THE USA
<b>OVERALL DIAMETER</b>	Elem1: .184" Nom.; Elem2: .207" Nom.; Elem3: .126" Nom.; Elem4: .145" Nom; Outer Jacket: .415" Nom.
<b>CABLE WEIGHT</b>	108 Lbs/Mft.
<b>CAPACITANCE</b>	Elem 1: 27 pF/Ft. Nom.; Elem 2: 51 pF/Ft. Nom.; Elem 3: 20 pF/Ft. Nom.; Elem 4: 20 pF/Ft.
<b>IMPEDANCE</b>	Elem 1: 70 Ohms; Elem 2: 27 Ohms; Elem 3: 94 Ohms; Elem 4 96 Ohms
<b>DC RESISTANCE</b>	Element 1: 6.66 Ohms/Mft. maximum @ 20 C Element 2: 16.9 Ohms/Mft. maximum @ 20 C Element 3: 16.9 Ohms/Mft. maximum @ 20 C Element 4: 16.9 Ohms/Mft. maximum @ 20 C
<b>TEMPERATURE RATING</b>	0 C to 75 C / 300 Volt

**INDUSTRY STANDARDS****FLAME RATING** Approved For Plenum Use Without Conduit Per NFPA 262 Flame Test**AGENCY APPROVALS** NEC Article 800; UL Listed C(UL)US CMP, RoHS Compliant, Made in the USA

All specifications referenced are nominal measurements unless otherwise noted.



## ADDENDUM # EIGHT (8)

TO  
THE CONTRACT DOCUMENTS  
FOR THE

Construction of Fire Station 15

IN  
HERNANDO COUNTY, FLORIDA

**SOLICITATION NO. 26-C01265/GB**

Bidders are required to acknowledge receipt of this Addendum via OpenGov prior to the time of the Bid Opening.

The following changes, additions are hereby made a part of the Contract Documents for the above-referenced Solicitation as fully and completely as if the same were fully set forth therein:

### **I. Questions and Answers**

**99.Q. Spec section 27 15 13 states installing Category 6 Data Cabling. Drawings (T-501-T-503) mention both Category 6 and Category 6A. Please verify which cabling should be installed Cat6 or Cat6A.**

99.A. Contractor shall provide Category 6 per Division 27 specifications issued. Refer to Attachment 8 – Ethernet and Fiber Communications Cabling

**100.Q. S601 Schedule shows 2 columns as 8x24, but what's pictured for C2 appears to have a changing width? Also, please note the heights of the cast in place columns.**

100.A. The column is 8"x24" the entire height. The columns go to the underside of the deck.

**101.Q. S202 shows a -2 ½ depression to the west, but then there are 5 positive 2 ½ rectangular areas to the east. Are these supposed to be shown as negative to indicate depressions in the slab or are they Housekeeping Pads to be followed as shown on 3-021/S301?**

101.A. All of the 2 1/2" depressions are slab depressions.

**102.Q. Does the mast arm require additional engineering other than shown on the plans to ensure the structural integrity of the arm - and the footing?**

102.A. The mast arm assembly was designed according to FDOT Standard Plan Index 649-030 and 649-031. These indices detail the design of FDOT Standard cantilever signal support structures in accordance with the AASHTO LRFD LTS Design Specifications. As noted on Sheet No. 16, the foundation data is based on cohesionless soil conditions with a friction angle of 30 degrees, N=15, and unit weight of soil = 50 PCF. The contractor will need to confirm in-situ soil conditions with a geotechnical engineer at each foundation location prior to installation. If undesirable soil conditions are found (i.e., conditions outside the bounds for which the standard details apply) through soil testing, then the design of the



## PROCUREMENT DEPARTMENT

15470 FLIGHT PATH DRIVE ♦ BROOKSVILLE, FLORIDA 34604  
P 352.754.4020 ♦ F 352.754.4199 ♦ W [www.HernandoCounty.us](http://www.HernandoCounty.us)

mast arm assembly will need to be re-assessed for possible modification, or the soils replaced to meet necessary conditions.

**103.Q. Are electrical circuits required at the irrigation for pumps or controller? Are there electrical circuits required for the shallow well pump?**

103.A. Yes, electrical circuits are required for the irrigation pump, irrigation controller, and shallow well pump. The irrigation pump location shall be determined in the field by the Contractor in coordination with the Owner. For bidding purposes, assume a 208V/3P, 7.5 HP irrigation pump. Provide the following:

30A/3P NEMA 3R heavy-duty, motor-rated disconnect switch, including pedestal Unistrut support for mounting

30A/3P, 208V circuit breaker with (4) #10 AWG and (1) #10 ground in 1" exterior-rated underground conduit

Dedicated 120V, 20A receptacle with weatherproof cover for irrigation pump service, per NEC

Dedicated 120V, 20A circuit for the irrigation pump controller, to be located on the exterior building wall

**104.Q. Does the mast arm at the lightning protection require additional engineering due to the height and the fact it is tied to the roof?**

104.A. The lightning protection mast will be revised to a wall-mounted configuration, anchored to the concrete beam, eliminating the need for roof attachment.

**105.Q. Are bollards required at the transformer, the backflow preventer or the DDCA assembly?**

105.A. No, bollards are not required

**106.Q. Please verify the quantity of the Saw Palmetto plants - they are at variance with the plant list, and the actual call out on the plans. 97 vs 93**

106.A. Saw Palmetto quantities total 93.

**107.Q. Please verify the quantity of Muhly Grass. The quantities are at variance with the plant list and the call out - 1038 vs 1069 - which one is correct?**

107.A. Muhly Grass quantities total 1069.

**108.Q. Since the propane is being deleted - what happens to the appliances and BBQ grill. Do they remain? Do they change to electric?**

108.A. Refer to Addendum 5, response to question 54.

**109.Q. Structural wall S202/column line 5 shows the wall at the apparatus bay to be a W8-5-24S. Structural page S203 shows the same wall at column line 5 as a CB-5-18s. Which is correct?**

109.A. The wall type changes at the top of the wall. See the elevations, sections and isometric views.

**110.Q. In the equipment schedule shown on ID-301 - There are several items that are shown without responsibility designations. Who is responsible for those items such as the Coffee Brewer, Aluminum Bench, the Microwave, French door refrigerator, stainless steel corner shelf, 6-digit countdown timer, etc.**



## PROCUREMENT DEPARTMENT

15470 FLIGHT PATH DRIVE ♦ BROOKSVILLE, FLORIDA 34604  
P 352.754.4020 ♦ F 352.754.4199 ♦ W www.HernandoCounty.us

110.A. Coffee Brewer = provided by GC, Installed by GC

Aluminum bench = provided by GC, Installed by GC

Microwave = provided by GC, Installed by GC

Refrigerators = provided by GC, Installed by GC

SS Corner shelf = provided by GC, Installed by GC

Timer = provided by GC, Installed by GC

**111.Q. Can you please tell me where the Acrovyn Wall panels are on the plans? The finish schedule does not show it as a wall finish.**

111.A. Please remove the Acrovyn Wall panels from the project scope

**112.Q. We are submitting the CSC Canam Steel Corporation Architectural Deck System as an or equal product in lieu of the Epicore ER2R product shown / specified in the plans. A separate email will be sent directly with the PDF attachment of the product specifications for review since there is no way to submit via the OpenGov Portal. This alternate product will provide potential cost savings for the project if it is reviewed to meet the same specifications required. Thanks for the consideration.**

112.A. Attachment 9 – CSC-Reveal-Series\_08-27-20

It is the Contractor's responsibility to verify product compatibility, performance criteria, and compliance with the specified system requirements. the Contractor shall submit a substitution request in accordance with the substitution procedures specified in the contract documents for review by the design team. Any other proposed substitution would be considered as a value engineering solution once the bid is awarded and the substitution is properly submitted per the project manual.

### II. Changes

1. Attachment 8 – Ethernet and Fiber Communications Cabling
2. Attachment 9 – CSC-Reveal-Series\_08-27-20
3. **BID OPENING IS CHANGED TO APRIL 27, 2026 AT 10:00 AM.**

**BOARD OF COUNTY COMMISSIONERS  
OF HERNANDO COUNTY, FLORIDA**

*Felicia Holmes*

For: Carla Rossiter-Smith MSM, PMP, GPC  
Chief Procurement Officer